

— PROPRIETARY —
 THIS DOCUMENT CONTAINS CONFIDENTIAL, PROPRIETARY INFORMATION
 THAT IS FOX PROPERTY. DO NOT DISCLOSE TO OR DUPLICATE
 FOR OTHERS EXCEPT AS AUTHORIZED BY FOX.

DIRECT MOUNT AND DIRECT MOUNT WIDE SH12 CRANK ASSEMBLY

REVISIONS

ZONE	REV	DESCRIPTION	DATE	BY	CHECKED
	A	INITAL RELEASE	2022-01-29	FA	DRB

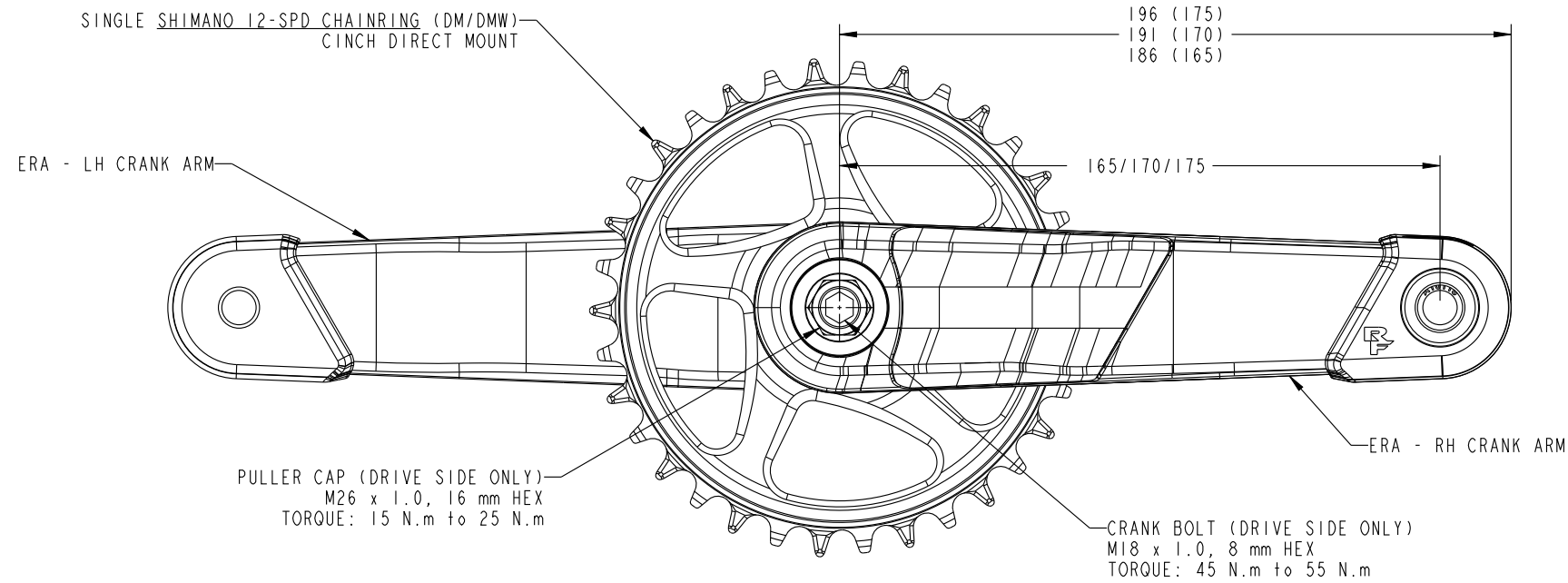

TABLE 1

NUMBER OF TEETH	CHAINRING RADIUS
30	64.8
32	68.8
34	72.8

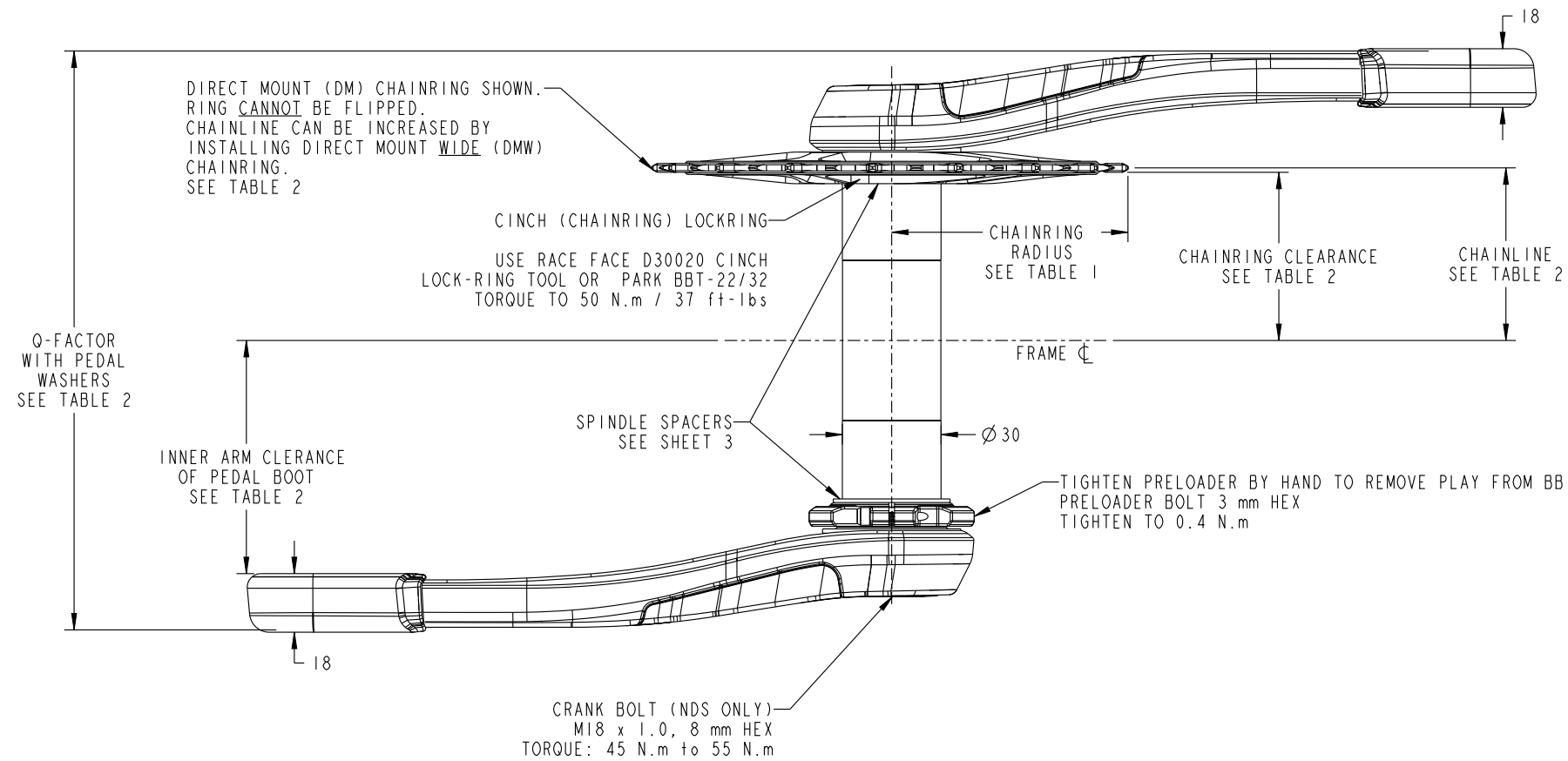

TABLE 2

SPINDLE	INTENDED BOTTOM BRACKET WIDTH	DM CHAINRING		DMW CHAINRING		INNER ARM CLERANCE WITH PEDAL BOOT	Q-FACTOR
		CHAINLINE	CHAINRING CLEARANCE	CHAINLINE	CHAINRING CLEARANCE		
RF136	98	52.0	50.0	55.0	53.5	70	176
RF143	98	55.5	53.5	58.5	57.0	77	183
RF149	113	58.5	56.5	61.5	60.0	83	189
RF169	130	68.5	66.5	71.5	70.0	93	209
RF189	130	78.5	76.5	81.5	80.0	103	229



FOX FACTORY INC.
 SPECIALTY SPORTS GROUP
 *118 - 8333 EASTLAKE DRIVE
 BURNABY BC, V5A 4W2

CUSTOMER DRAWING, CRANKSET, ERA

SIZE	PART NO.	REVISION
B	OCK23ERA-CUST	A
PLOT SCALE 1:2		SHEET 1 OF 3

DIRECT MOUNT 11-12 SPEED CRANK ASSEMBLY

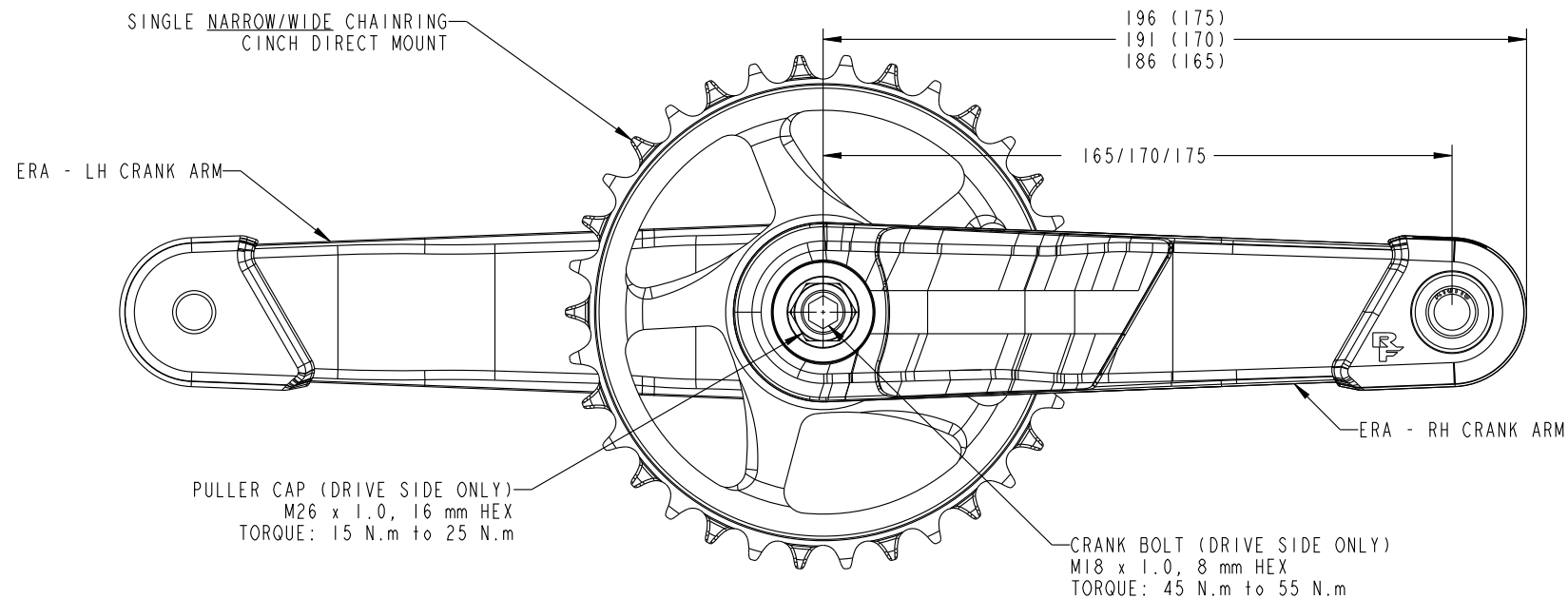

TABLE 3

NUMBER OF TEETH	CHAINRING RADIUS
26	55.5
28	59.6
30	63.6
32	67.7
34	71.7
36	75.8

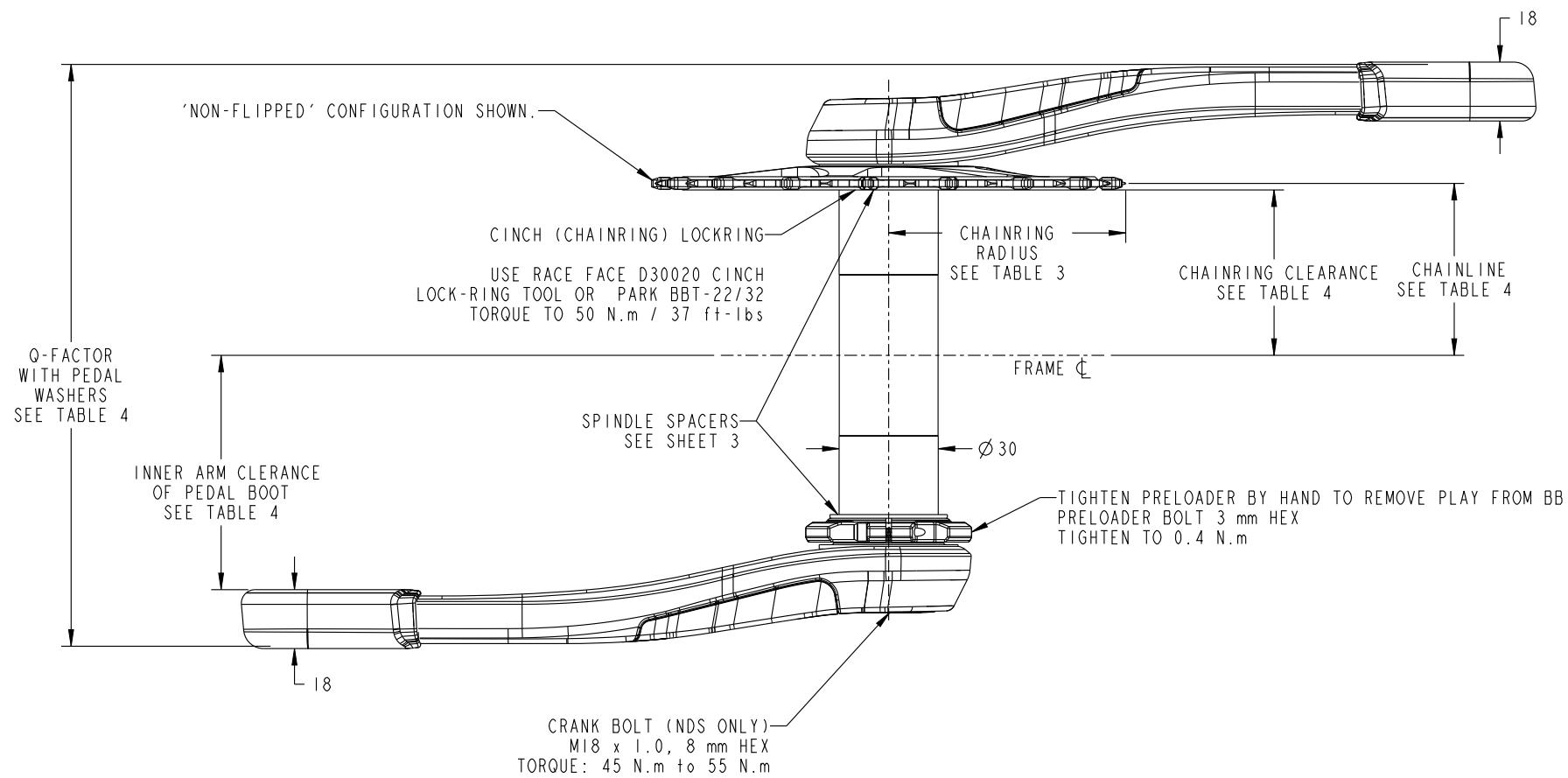

TABLE 4

SPINDLE	INTENDED BOTTOM BRACKET WIDTH	CHAINLINE	CHAINRING CLEARANCE	INNER ARM CLEARANCE WITH PEDAL BOOT	Q-FACTOR
RF136	98	52.0	50.0	70	176
RF143	98	55.5	53.5	77	183
RF149	113	58.5	56.5	83	189
RF169	130	68.5	66.5	93	209
RF189	130	78.5	76.5	103	229

— PROPRIETARY —
THIS DOCUMENT CONTAINS CONFIDENTIAL, PROPRIETARY INFORMATION THAT IS FOX PROPERTY. DO NOT DISCLOSE TO OR DUPLICATE FOR OTHERS EXCEPT AS AUTHORIZED BY FOX.

SIZE B	CAGE NO. NONE	DWG. NO. OCK23ERA-CUST	REV. A
PLOT SCALE 1:2		2 OF 3	

SPACER CONFIGURATIONS

(BY SPINDLE LENGTH)

RF136 SPINDLE

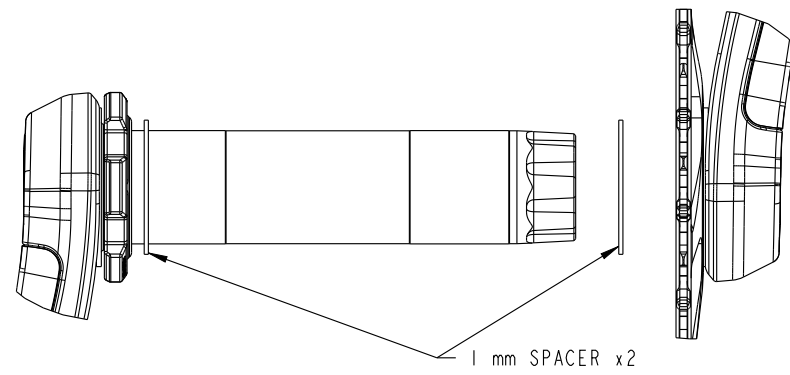

RF143 SPINDLE

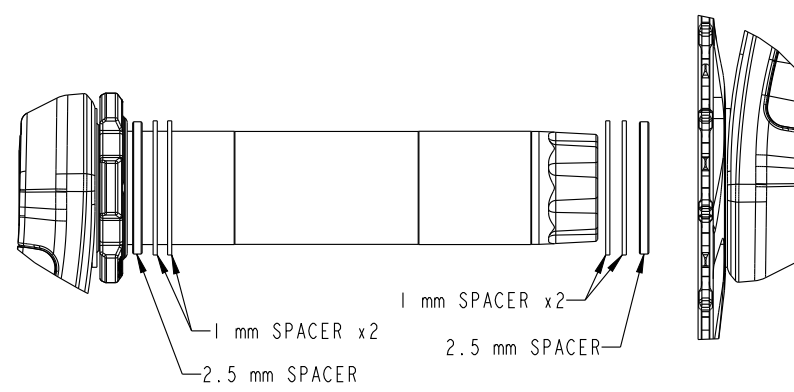

RF149 SPINDLE

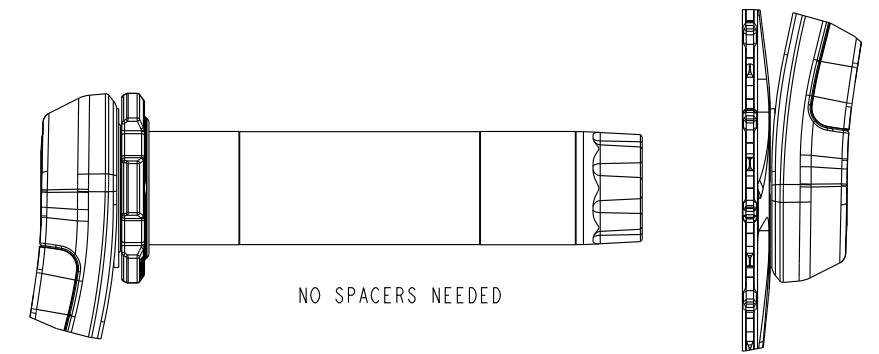

RF169 SPINDLE

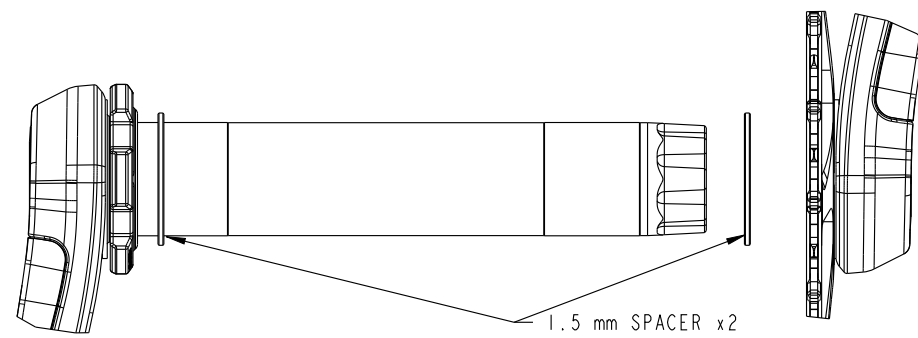

RF189 SPINDLE

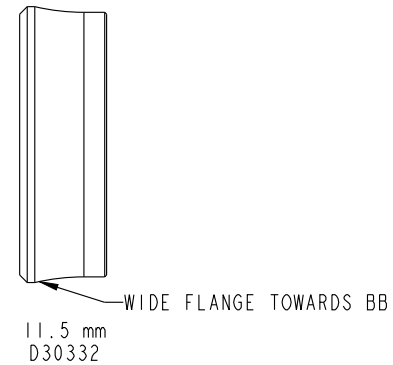
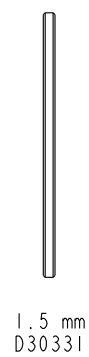
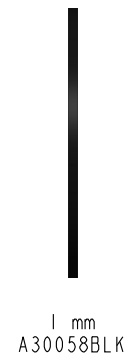
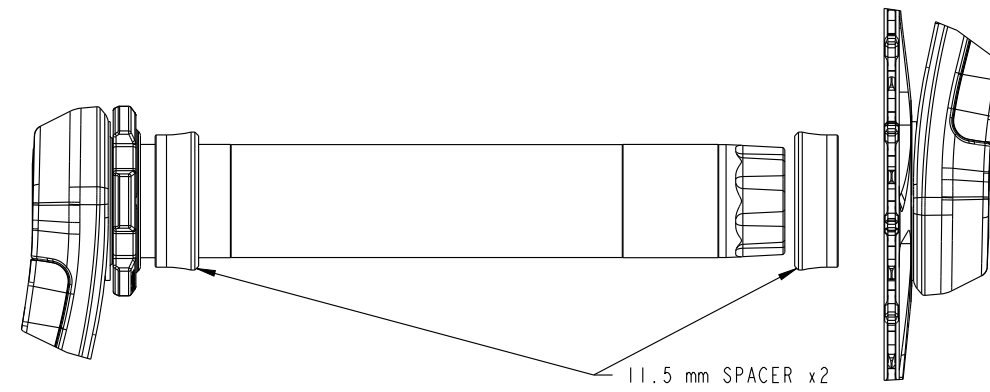

SCALE 1:1

— PROPRIETARY —
THIS DOCUMENT CONTAINS CONFIDENTIAL, PROPRIETARY INFORMATION THAT IS FOX PROPERTY. DO NOT DISCLOSE TO OR DUPLICATE FOR OTHERS EXCEPT AS AUTHORIZED BY FOX.

SIZE B	CAGE NO. NONE	DWG. NO. OCK23ERA-CUST	REV. A
PLOT SCALE 1:2		3 OF 3	