



TEXACO

# DELO DURABILITY FOR THE MINING, QUARRYING & CONSTRUCTION INDUSTRIES



**DeLo**<sup>®</sup>  
Let's go further.®

## WELCOME TO TEXACO® DELO® PRODUCTS

Keeping your equipment going is part of our business. Making the most of your investment is yours. At Chevron, we understand just how critical both of these are to your mining, quarrying or construction operation and livelihood.

Thank you for the opportunity to let us introduce you to the Delo product line, providing bumper-to-bumper protection.

We'll share why Delo with ISOSYN® Technology helps provide the world-class protection customers need to be confident they are maximising productivity and minimising operating costs.

You'll also see how Delo 400 engine oils compare to competitive products in testing and what our customers are saying about the value Delo contributes to their business and bottom line, in a wide range of operating conditions.

We consider this guide to be an introduction. We look forward to learning more about the needs of your mining, quarrying or construction operation and how our full suite of Texaco products can help you and your business go further.

## DELO®: A HISTORY OF FIRSTS



**1936**

Marketed first compounded diesel engine oil making high speed diesel engines feasible



**1953**

First in world to develop successful multigrade engine oil



**1989**

First to document million mile, no overhaul engine life in Caterpillar 3406B



**1998**

First heavy duty engine oil to meet the API CH-4, Cummins CES 20076 and Mack EO-M Plus extended drain specifications



**2013**

Chevron receives SAE research award for 'Extending the Boundaries of Diesel Particulate Filter Maintenance with Ultra-Low Ash - Zero-Phosphorus Oil'



**2014**

Launched first low emission oil (API CJ-4) formulated to protect diesel engines using up to 5,000ppm diesel fuel sulphur levels



### Delo family of products.

Helping you achieve optimum performance out of every hour by delivering extended service protection, helping maximise engine durability and minimise operating cost.

# LET'S GO FURTHER WITH TEXACO® DELO®



When your heavy duty off-highway equipment is working reliably, your business is driving production and profits. At Chevron, our goal is to optimise your equipment performance, to help minimise operating costs and maximise engine reliability.

As your lubrication partner, we strive to keep your comprehensive fleet of equipment running reliably. This includes diesel engines, transmissions, final drives, hydraulic systems, pins and bushings, compressors, draglines, add pumps, conveyors, material processing equipment and generators, helping to minimise operating costs and maximise performance.

We understand the challenges facing off-highway equipment, components and sites today:

- New engine technology development
- Fuel type and quality
- Extending oil and coolant drain intervals
- Protecting equipment from premature wear due to contamination from the working environment such as air, water and dirt ingress
- Consolidation of lubricant products, without sacrificing performance
- Maintaining efficiency and emission controls
- Meeting legal requirements.

Count on Chevron's industry experience, technology leadership and the Delo family of premium products to stay ahead of these challenges and help protect and maximise the life of your key equipment.



## Reliability and durability are our priority

Chevron lubricants stand for one thing above all else – reliability. Properly lubricating the inside of a heavy duty diesel engine requires more than just creating a protective film. Delo heavy duty engine oils provide soot dispersancy, wear protection and sludge control, to guard against loss of engine life and help reduce fuel and oil consumption.

Additionally, the Delo family of products deliver integrity and performance as proven by various bench testing results. Delo's industry-leading lubricants and coolants have logged countless hours providing protection to diesel engine parts and key equipment components, so your mobile and static equipment can go further.



Delo® with ISOSYN® Technology gives you the performance, protection and confidence you need to help your business go further.

## What is ISOSYN?

ISOSYN Technology is how Chevron formulates its top-tier Delo products. It's the combination of premium base oils with high performance additives and Chevron's formulation expertise that provides protection for diesel engine parts. All at great value.

Delo with ISOSYN Technology gives you the performance, protection and confidence you need to help your business go further.

- Provides extended service protection
- Helps maximise engine durability
- Helps minimise operating costs.

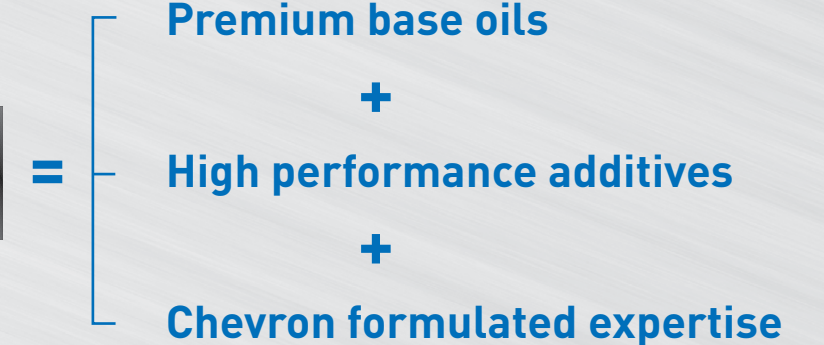

## Focused parts protection

Delo with ISOSYN Technology protects critical engine parts to help maximise engine and equipment life.



# HEAVY DUTY ENGINE OILS PROVIDING WORLD-CLASS PROTECTION



Helping your equipment and business go further, we have the proven lubrication products to fit your needs.

Delo® oils are formulated to provide diesel engine parts protection and performance in the wide range of operating conditions experienced by off-highway equipment. For decades, Delo has been committed to helping customers in the mining, quarrying and construction sectors operate their business more efficiently.

<p><b>Delo 400 XSP-FA SAE 5W-30</b></p> <p>Long-drain FA-4 low SAPS engine oil for newer engines, with optimum fuel economy performance</p> <p>Product highlights:</p> <ul style="list-style-type: none"> <li>Helps improve fuel economy by up to 1.3%</li> <li>Offers good keep-clean performance</li> <li>Promotes cylinder, piston and valve train wear protection</li> <li>Contributes to maximum vehicle service life</li> <li>Aids emissions control system service life</li> <li>Low temperature flow and pumpability</li> </ul>	<p><b>NEW</b></p>
<p><b>Delo 400 XSP-SD SAE 5W-30</b></p> <p>Long-drain CK-4, E6/E7/E9 engine oil with optimum fuel economy performance</p> <p>Product highlights:</p> <ul style="list-style-type: none"> <li>Designed for improved fuel economy</li> <li>Offers extended drain wear protection</li> <li>Designed for cold start protection</li> <li>Formulated for keep-clean performance</li> <li>Helps minimise DPF cleaning</li> <li>Offers wear, oxidation and sludge control</li> </ul>	<p><b>NEW</b></p>
<p><b>Delo 400 XLE SAE 10W-30</b></p> <p>Long-drain CK-4, E6/E9 low SAPS engine oil with some fuel economy benefits</p> <p>Product highlights:</p> <ul style="list-style-type: none"> <li>Designed for high performance oxidation resistance</li> <li>Promotes wear and corrosion protection</li> <li>Helps improve fuel economy</li> <li>Backwards compatible</li> <li>Formulated for optimum DPF life</li> <li>Offers low temperature protection</li> </ul>	
<p><b>Delo 400 MGX SAE 15W-40</b></p> <p>Low SAPS CJ-4, E7/E9 engine oil with strong TBN retention, for use in high and low sulphur fuel regions</p> <p>Product highlights:</p> <ul style="list-style-type: none"> <li>Wide range of uses helps minimise misapplication</li> <li>Reduces large oil inventories and costs</li> <li>Helps control soot and valve train wear</li> <li>Designed for optimum service with minimal maintenance</li> <li>Formulated to aid DPF service life</li> </ul>	

<p><b>Delo 400 LE Synthetic SAE 5W-40</b></p> <p>Heavy-duty synthetic CJ-4, E7/E9 diesel engine oil</p> <p>Product highlights:</p> <ul style="list-style-type: none"> <li>Formulated for protection in latest ULSD diesel engines</li> <li>Designed with low SAPS technology</li> <li>Helps protect against wear, corrosion, deposits and soot</li> <li>Suitable for mixed fleets</li> <li>Promotes cold start wear protection</li> <li>Offers wide temperature operations</li> </ul>	<b>NEW</b>
<p><b>Delo 400 XLE HD SAE 10W-40</b></p> <p>Long-drain CJ-4, E4/E6/E7/E9 low SAPS engine oil</p> <p>Product highlights:</p> <ul style="list-style-type: none"> <li>Suitability for a wide range of OEM applications helps reduce inventories</li> <li>Helps keep piston rings, piston lands and valves clean</li> <li>Offers latest technology engine protection</li> <li>Formulated to reduce emission control system maintenance</li> <li>Designed for extended oil drain intervals</li> <li>Promotes good cold start wear protection</li> </ul>	
<p><b>Delo Gold Ultra E SAE 15W-40</b></p> <p>CI-4, E7 engine oil</p> <p>Product highlights:</p> <ul style="list-style-type: none"> <li>Promotes resistance to low temperature sludge and high temperature deposits</li> <li>Engine and bearing corrosion protection</li> <li>Offers protection against wear and bore polishing</li> <li>Formulated to protect against deposits and filter plugging</li> </ul>	
<p><b>Delo 400 RDE SAE 10W-30</b></p> <p>Long-drain CI-4, E6/E7/E9 low SAPS engine oil with some fuel economy benefits</p>	<p><b>Delo 400 RDS SAE 10W-40</b></p> <p>Long-drain CI-4, E6/E7/E9 low SAPS engine oil</p>
<p><b>Delo Gold Ultra T SAE 10W-40</b></p> <p>Long-drain CI-4, E4/E7 engine oil</p>	<p><b>Delo Gold Ultra E SAE 10W-40</b></p> <p>CI-4, E7 engine oil</p>
<p><b>Delo Gold Ultra SAE 10W-30</b></p> <p>Low viscosity CH-4 engine oil</p>	



**We are actually saving about \$160,000 per engine, per year using Delo 400 engine oils. Our mine runs a fleet of 21 trucks, so you are looking at roughly \$3 million in savings per year, and 7,000 hours equates to over a year's operating time at the mine.**

**Scott Jackson**  
Senior Maintenance Planner, ASARCO Ray Copper Mine

# HEAVY DUTY ENGINE OILS WITH PROVEN PERFORMANCE RESULTS



## Robust real world testing

Every day, your off-highway equipment can put heavy duty engine oils to the test with extreme operating conditions, extended oil-drain performance and high loads, to help ensure on-time production work. Delo® goes further to prove its value across your diesel equipment.

In head-to-head field testing, Delo 400 MGX SAE 15W-40 was tested against a well-known leading competitor API CJ-4 product. Delo 400 MGX SAE 15W-40 performed well with comparable TBN retention and showed directionally better acid neutralisation performance.

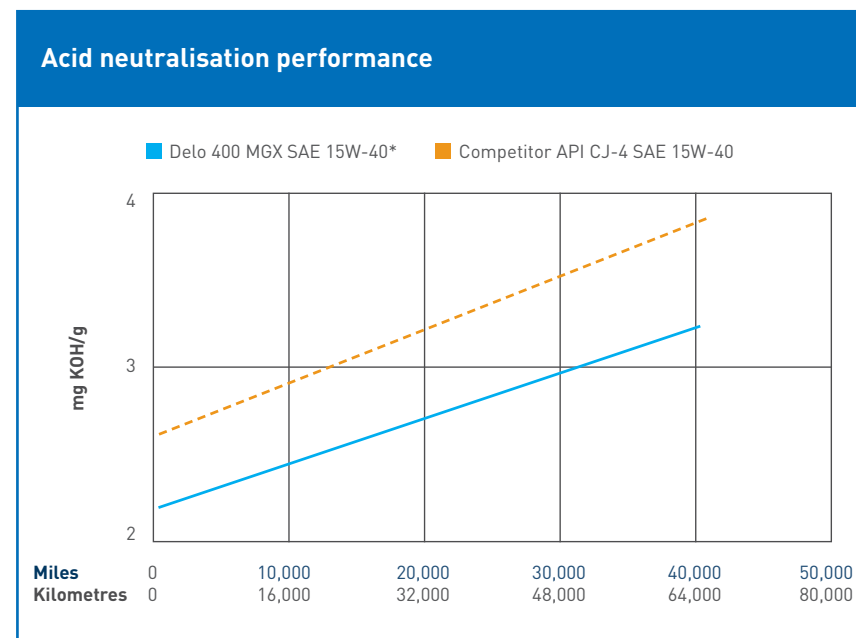

### Total acid number test

Delo 400 MGX delivered acid neutralisation even in extended-drain applications and performed better than a leading competitor API CJ-4 oil.

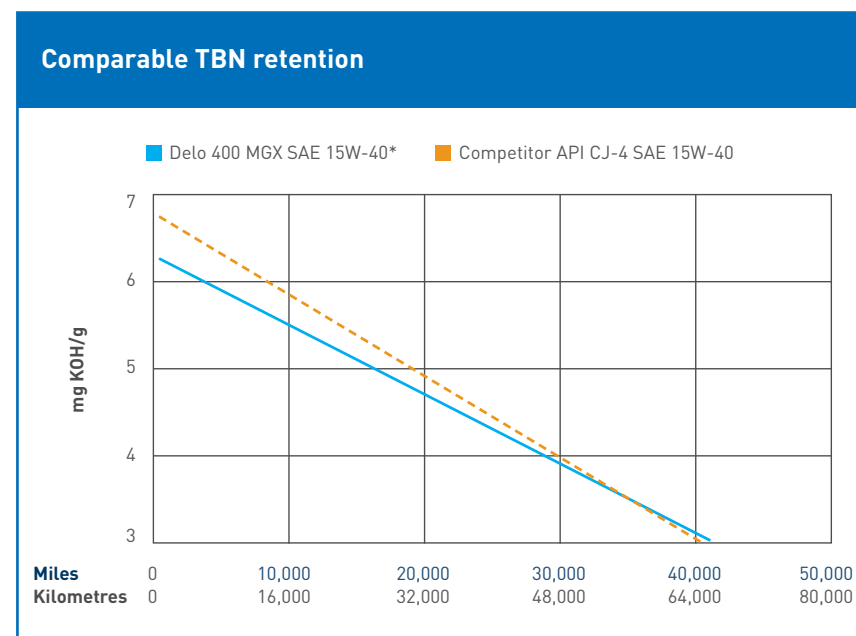

### Total base number test

Delo 400 MGX shows lower rate of alkalinity loss indicating its capability to neutralise acids and still retain its effectiveness even in extended-drain applications. Shows better performance than a leading competitor API CJ-4 engine oil.

\* Chart data relates to Delo 400 MGX SAE 15W-40 product blended in Port Arthur, Texas

## A&A Ready Mix Concrete Inc. achieves long engine life and extended oil drains in MACK cement mixer engines, using Delo® 400 engine oil

Based in Long Beach, California, A&A Ready Mix Concrete operates over 770 trucks with MACK engines and 35 large pieces of construction equipment. They have operated over 30 years in Southern California, hauling concrete and aggregate material for various construction projects including highways, bridges and commercial buildings.

A&A Concrete has used Delo 400 for more than 13 years and started using the full family of Delo products in 2001, with impressive results.

After some of their cement mixers reached a total of over 27,000 hours while doing 1,100 hour oil drain intervals using Delo 400 engine oil, Chevron and A&A agreed to tear down one of the MACK E7 engines to check engine parts protection and wear performance. The tear down was a great success with all parts showing good protection. A&A Concrete personnel were pleased with their decision to trust Delo 400 engine oil to help their business go further.



We are really impressed with how the MACK engine parts look after 27,000 hours using Delo 400 engine oil. We recently purchased \$5.5M worth of new cement trucks and we will continue to trust the Delo Family of Products to protect our new investment.

Mike Cook  
Fleet/Purchasing Manager,  
A&A Ready Mix Concrete Inc.

### Piston

Shows minimal deposit formation and very good cleanliness. Pistons were really clean on viewing and show effective protection even at extended oil drain intervals.



### Piston liner

Crosshatching is well intact and shows minimal wear after 27,000 total hours doing 1,100 hour oil drain intervals using Delo 400 engine oil.



### Main bearings

Thrust side shows minimal wear and very good condition indicating that Delo 400 engine oil provides long-term protection at extended drain intervals.



### Cam shaft/Roller followers

Cam shafts and rollers are in very good condition with minimal visible abrasive wear or spalling.



# PROTECTING YOUR HEAVY DUTY EQUIPMENT, BUMPER-TO-BUMPER

Working in the mining, quarrying and construction industries, your equipment works in the harshest environments, requiring premium products to achieve high-level reliability and performance, at the lowest total operating costs.

Delo® heavy duty engine oils, drive train fluids, final drive fluids, greases and extended life coolants are specially formulated to help meet the intense demands your equipment faces.

Choosing the proven performance of Delo® quality lubricants supports an operator's need for optimal reliability and performance, under diverse operating conditions and for long periods of time. This could mean a higher return on investment, hour after hour.

At Chevron, we have a history of heavily investing in research and development to ensure your equipment gets the utmost protection from bumper-to-bumper. We're so confident about the quality of Delo products, that we offer a bumper-to-bumper warranty you may not find from other manufacturers.

For a full list of product recommendations for your equipment, visit: [chevron-eu.lubricantadvisor.com](http://chevron-eu.lubricantadvisor.com)

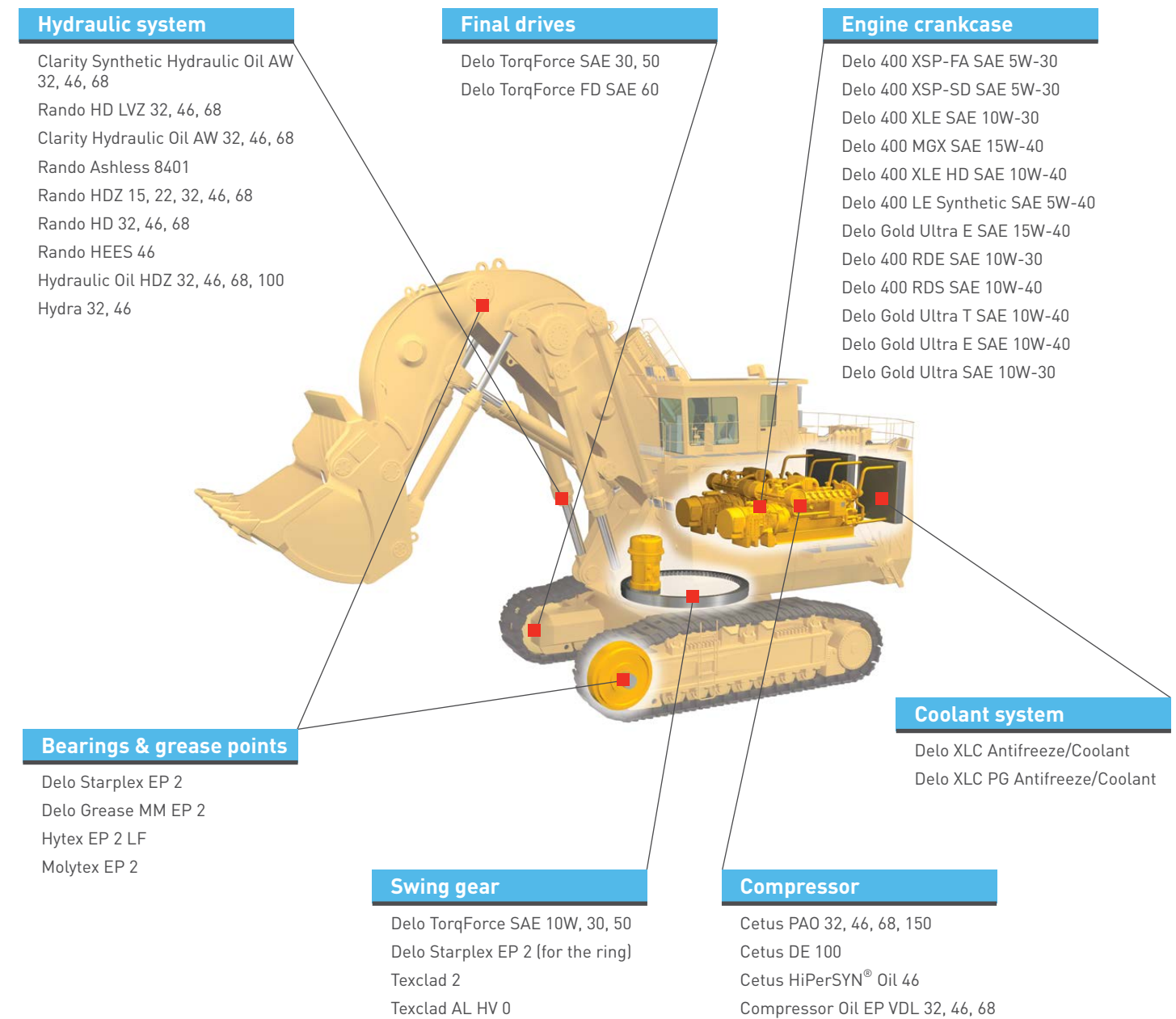
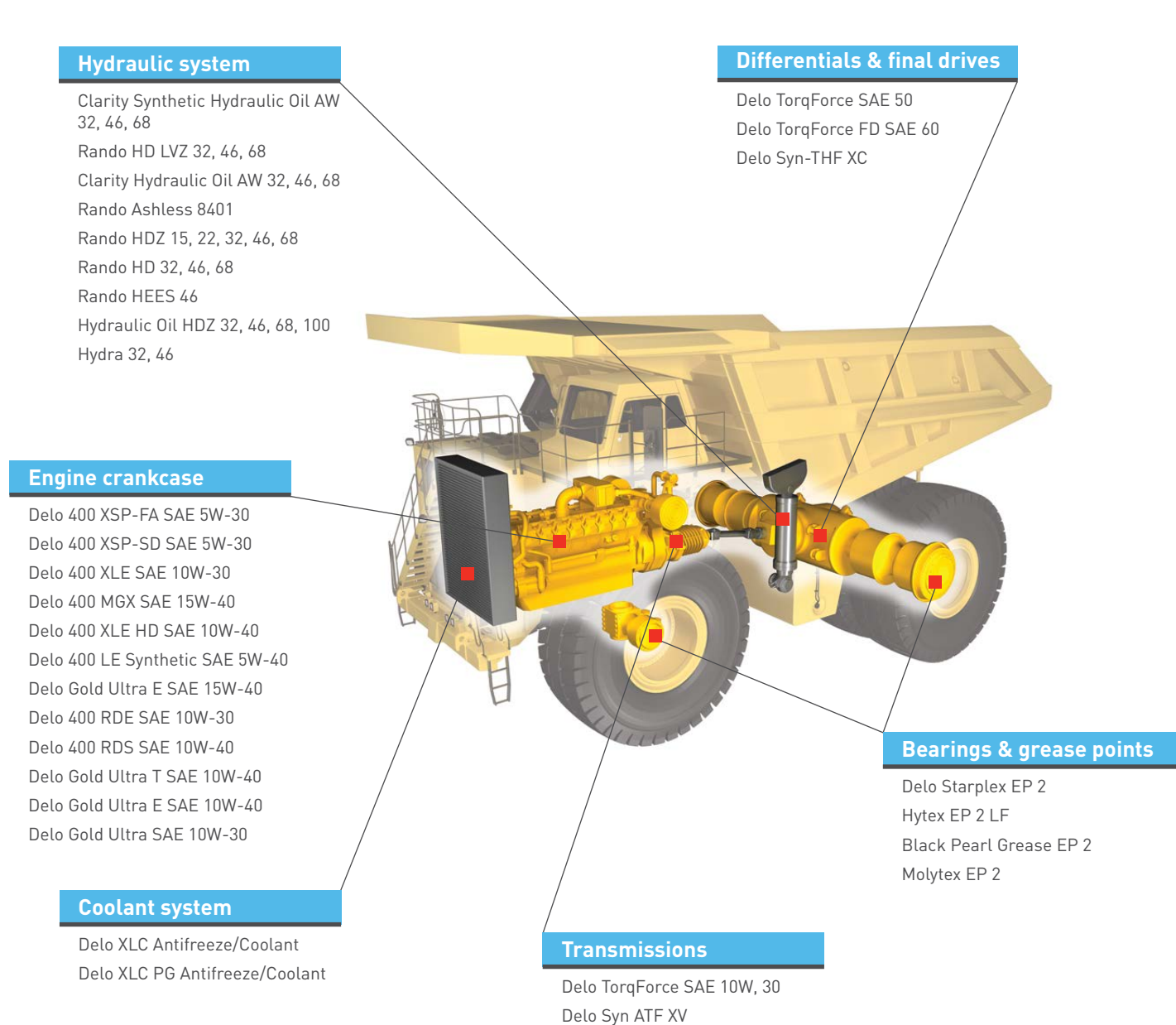

### Hydraulic system

Clarity Synthetic Hydraulic Oil AW 32, 46, 68  
 Rando HD LVZ 32, 46, 68  
 Clarity Hydraulic Oil AW 32, 46, 68  
 Rando Ashless 8401  
 Rando HDZ 15, 22, 32, 46, 68  
 Rando HD 32, 46, 68  
 Rando HEES 46  
 Hydraulic Oil HDZ 32, 46, 68, 100  
 Hydra 32, 46

### Engine crankcase

Delo 400 XSP-FA SAE 5W-30  
 Delo 400 XSP-SD SAE 5W-30  
 Delo 400 MGX SAE 15W-40  
 Delo 400 XLE HD SAE 10W-40  
 Delo 400 XLE SAE 10W-30  
 Delo 400 RDE SAE 10W-30  
 Delo 400 RDS 10W-40  
 Delo 400 LE Synthetic SAE 5W-40  
 Delo Gold Ultra E SAE 10W-40, 15W-40  
 Delo Gold Ultra T SAE 10W-40  
 Delo Gold Ultra SAE 10W-30

### Coolant system

Delo XLC Antifreeze/Coolant

### Bearings & grease points

Delo Starplex EP 2  
 Hytex EP 2 LF  
 Black Pearl Grease EP 2  
 Molytex EP 2

### Transmissions

Delo Syn-ATF XV  
 1000 THF  
 Delo TorqForce SAE 10W, 30  
 Delo 400 RDE SAE 10W-30

### Differentials & final drives

1000 THF  
 Delo Syn-THF XC  
 Delo TorqForce SAE 30, 50  
 Delo TorqForce FD SAE 60  
 Geartex LS SAE 85W-90

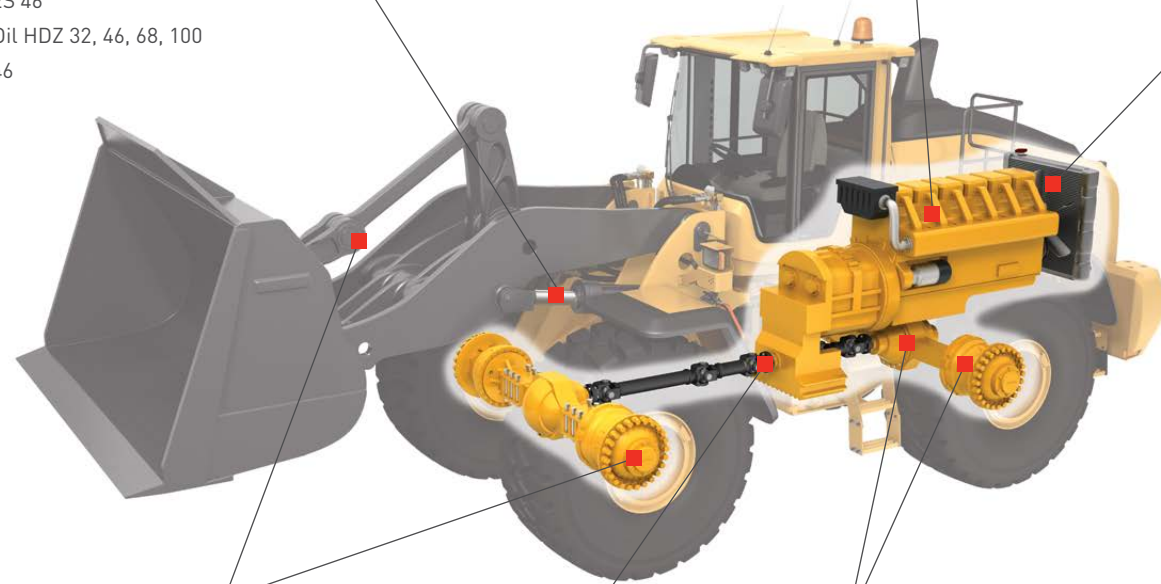

### Engine crankcase

Delo 400 XSP-FA SAE 5W-30  
 Delo 400 XSP-SD SAE 5W-30  
 Delo 400 MGX SAE 15W-40  
 Delo 400 XLE HD SAE 10W-40  
 Delo 400 XLE SAE 10W-30  
 Delo 400 RDE SAE 10W-30  
 Delo 400 RDS 10W-40  
 Delo 400 LE Synthetic SAE 5W-40  
 Delo Gold Ultra E SAE 10W-40, 15W-40  
 Delo Gold Ultra T SAE 10W-40  
 Delo Gold Ultra SAE 10W-30

### Coolant system

Delo XLC Antifreeze/Coolant

### Transmissions

Delo Syn ATF XV  
 Delo 400 RDE SAE 10W-30  
 Delo TorqForce SAE 10W, 30

### Hydraulic system

Clarity Synthetic Hydraulic Oil AW 32, 46, 68  
 Rando HD LVZ 32, 46, 68  
 Clarity Hydraulic Oil AW 32, 46, 68  
 Rando Ashless 8401  
 Rando HDZ 15, 22, 32, 46, 68  
 Rando HD 32, 46, 68  
 Rando HEES 46  
 Hydraulic Oil HDZ 32, 46, 68, 100  
 Hydra 32, 46

### Bearings & grease points

Delo Starplex EP 2  
 Hytex EP 2 LF  
 Black Pearl Grease EP 2  
 Molytex EP 2

### Differentials & hub reduction

1000 THF  
 Delo TorqForce SAE 50  
 Delo TorqForce FD SAE 60  
 Delo Syn-Gear HD SAE 75W-90  
 Delo Gear TDL SAE 80W-90  
 Geartex EP-5 SAE 80W-90

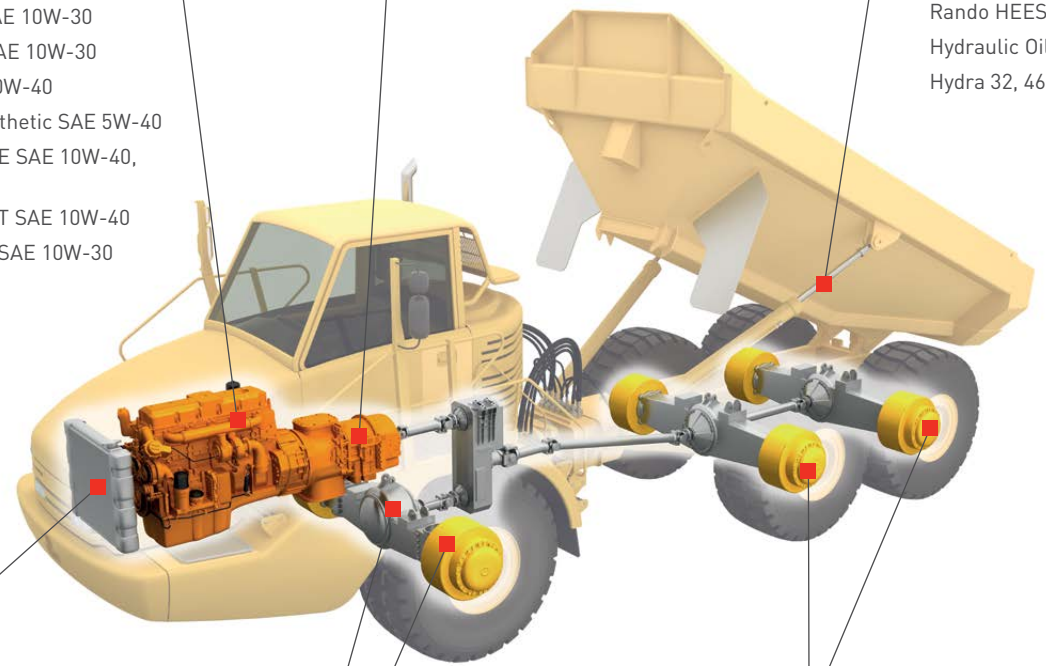

### Hydraulic system

Clarity Synthetic Hydraulic Oil AW 32, 46, 68  
Rando HD LVZ 32, 46, 68  
Clarity Hydraulic Oil AW 32, 46, 68  
Rando Ashless 8401  
Rando HDZ 15, 22, 32, 46, 68  
Rando HD 32, 46, 68  
Rando HEES 46  
Hydraulic Oil HDZ 32, 46, 68, 100  
Hydra 32, 46

### Engine crankcase

Delo 400 XSP-FA SAE 5W-30  
Delo 400 XSP-SD SAE 5W-30  
Delo 400 MGX SAE 15W-40  
Delo 400 XLE HD SAE 10W-40  
Delo 400 XLE SAE 10W-30  
Delo 400 RDE SAE 10W-30  
Delo 400 RDS 10W-40  
Delo 400 LE Synthetic SAE 5W-40  
Delo Gold Ultra E SAE 10W-40, 15W-40  
Delo Gold Ultra T SAE 10W-40  
Delo Gold Ultra SAE 10W-30

### Coolant system

Delo XLC Antifreeze/Coolant

### Transmissions

ATF HD 389  
Delo Syn ATF XV  
Delo 400 RDE SAE 10W-30  
Delo TorqForce SAE 10W, 30

### Differentials & final drives

1000 THF  
Delo Syn-THF XC  
Delo TorqForce SAE 30, 50  
Delo TorqForce FD SAE 60  
Delo Gear TDL SAE 80W-90  
Geartex LS SAE 85W-90  
Geartex EP-5 SAE 80W-90

### Bearings & grease points

Delo Starplex EP 2  
Hytex EP 2 LF  
Black Pearl Grease EP 2  
Molytex EP 2

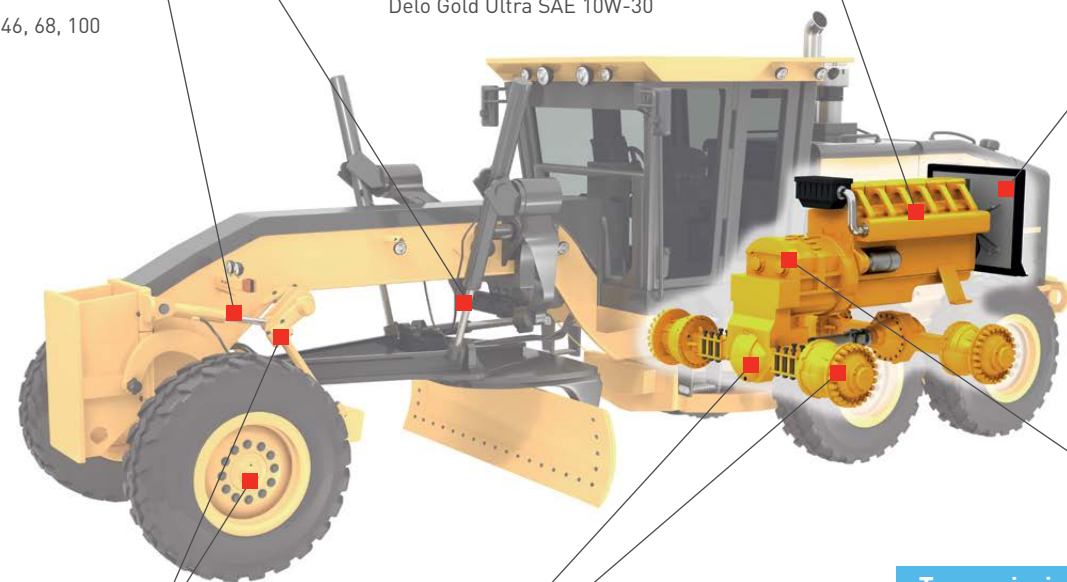

### Hydraulic system

Clarity Synthetic Hydraulic Oil AW 32, 46, 68  
Rando HD LVZ 32, 46, 68  
Clarity Hydraulic Oil AW 32, 46, 68  
Rando Ashless 8401  
Rando HDZ 15, 22, 32, 46, 68  
Rando HD 32, 46, 68  
Rando HEES 46  
Hydraulic Oil HDZ 32, 46, 68, 100  
Hydra 32, 46

### Coolant system

Delo XLC Antifreeze/Coolant

### Engine crankcase

Delo 400 XSP-FA SAE 5W-30  
Delo 400 XSP-SD SAE 5W-30  
Delo 400 MGX SAE 15W-40  
Delo 400 XLE HD SAE 10W-40  
Delo 400 XLE SAE 10W-30  
Delo 400 RDE SAE 10W-30  
Delo 400 RDS 10W-40  
Delo 400 LE Synthetic SAE 5W-40  
Delo Gold Ultra E SAE 10W-40, 15W-40  
Delo Gold Ultra T SAE 10W-40  
Delo Gold Ultra SAE 10W-30

### Transmissions

ATF HD 389  
1000 THF  
Delo TorqForce SAE 10W

### Bearings & grease points

Delo Starplex EP 2  
Hytex EP 2 LF  
Black Pearl Grease EP 2  
Molytex EP 2

### Differentials & final drives

1000 THF  
Delo Syn-THF XC  
Delo TorqForce SAE 30, 50  
Delo TorqForce FD SAE 60  
Delo Gear TDL SAE 80W-90  
Geartex EP-5 SAE 80W-90

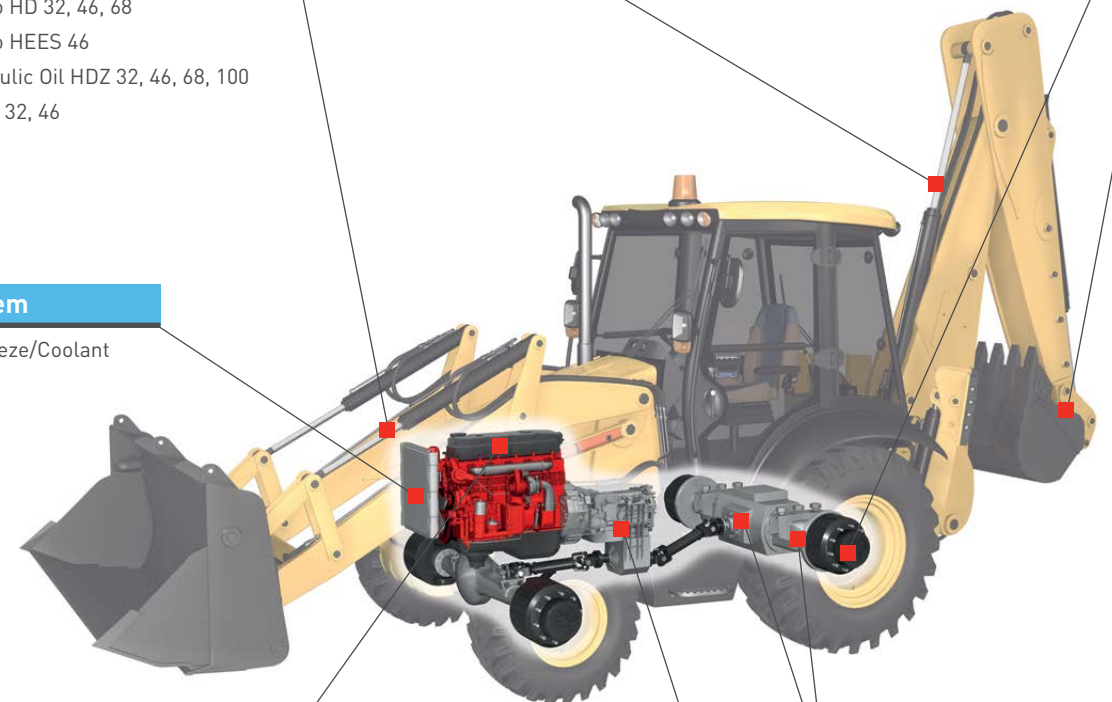



# PREMIUM FLUIDS FOR HYDRAULICS

# LONG-TERM PERFORMANCE FOR TRANSMISSIONS & DIFFERENTIALS

Texaco® has a comprehensive range of hydraulic oils, including mineral, synthetic and biodegradable fluids, suitable for use in a wide range of applications.

<b>Clarity Synthetic Hydraulic Oil AW 32, 46, 68</b>	
Zinc-free premium performance synthetic hydraulic oils, also suitable in environmentally sensitive areas	
Product highlights:	
<ul style="list-style-type: none"> <li>Ultra high performance wear and oxidation protection</li> <li>Rust and corrosion resistance</li> </ul>	<ul style="list-style-type: none"> <li>Hydrolytic stability, rapid water separation, foam inhibition and filterability</li> <li>Very low acute aquatic toxicity</li> </ul>
<b>Rando HD LVZ 32, 46, 68</b>	
Zinc-based premium performance high productivity synthetic hydraulic oils	
Product highlights:	
<ul style="list-style-type: none"> <li>Helps ensure protection in all-weather start-ups</li> <li>Contributes to longer drain periods and uptime</li> </ul>	<ul style="list-style-type: none"> <li>Formulated for wet operating conditions</li> <li>Offers high temperature, high pressure protection</li> </ul>
<b>Clarity Hydraulic Oil AW 32, 46, 68</b>	<b>Rando Ashless 8401</b>
Ashless high performance long life hydraulic oils	Low pourpoint, high VI zinc-free hydraulic oil, meeting Swedish Army Standard FSD 8401
<b>Rando HDZ 15, 22, 32, 46, 68</b>	<b>Rando HD 32, 46, 68</b>
Multi-viscosity anti-wear hydraulic fluids	Zinc-based monograde hydraulic oils
<b>Rando HEES 46</b>	<b>Hydraulic Oil HDZ 32, 46, 68, 100</b>
Biodegradable, high premium performance ester based hydraulic oil; Ecolabel approved	Heavy duty zinc-based multi-viscosity anti-wear hydraulic oils
<b>Hydra 32, 46</b>	
Biodegradable hydraulic fluids for applications where environmental contamination may occur	

Protecting transmissions, gear drives and differentials is critical to achieving total equipment reliability.

Delo® lubricants are engineered for long life and oxidation resistance, offering friction retention, wear control, seal compatibility, oxidation stability and stay-in-grade viscosity performance, meeting a wide range of OEM specifications. They are formulated with specialised additive chemistry that allows for ultra-fine filtration to provide the necessary fluid cleanliness and equipment reliability performance.

<b>Delo TorqForce SAE 10W, 30, 50</b>	
Heavy duty transmission and drive train fluids	
Product highlights:	
<ul style="list-style-type: none"> <li>Offers severe high temperature, high load protection</li> <li>Promotes quiet control with minimum wear</li> </ul>	<ul style="list-style-type: none"> <li>High quality helps extend oil service life</li> <li>Keep-clean component protection</li> </ul>
<b>Delo TorqForce FD SAE 60</b>	
Heavy duty final drive oil	
Product highlights:	
<ul style="list-style-type: none"> <li>Helps minimise wear in severe high temperature, high load conditions</li> <li>Offers viscosity increase protection at 4,000-hour drain intervals</li> </ul>	<ul style="list-style-type: none"> <li>Designed for rust, corrosion and cold start protection</li> <li>Promotes foam suppression</li> </ul>
<b>Delo Syn ATF XV</b>	
Volvo 97342 approved transmission fluid	
Product highlights:	
<ul style="list-style-type: none"> <li>Offers resistance to sludge, lacquer and deposits</li> <li>Promotes consistent viscosity retention</li> <li>Designed for gear, bearing and clutch wear protection</li> </ul>	<ul style="list-style-type: none"> <li>Contributes to improved vehicle fuel economy</li> <li>Formulated for durable smooth shifting</li> </ul>
<b>Delo Syn-THF XC</b>	<b>Geartex LS SAE 85W-90</b>
Volvo 97304 (WB 102) approved synthetic wet brake transaxle fluid	Automotive gear lubricant formulated for use in limited slip differentials and API GL-5 applications

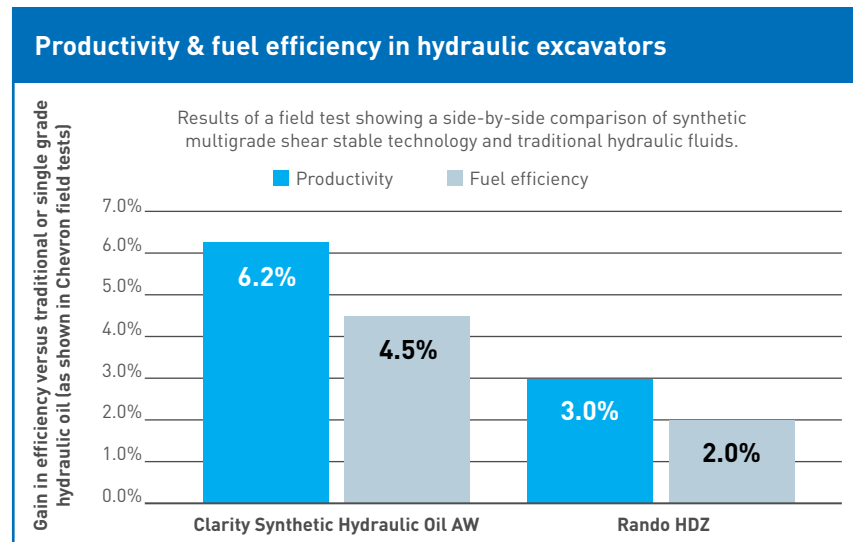

By using premium hydraulic fluids, productivity and fuel efficiency can be improved relative to traditional hydraulic oils, as shown here.

These improvements have been measured in side-by-side testing versus standard types of hydraulic oil. Results show up to a 6.2% increase in productivity (material moved per hour) and as much as a 4.5% increase in fuel efficiency.

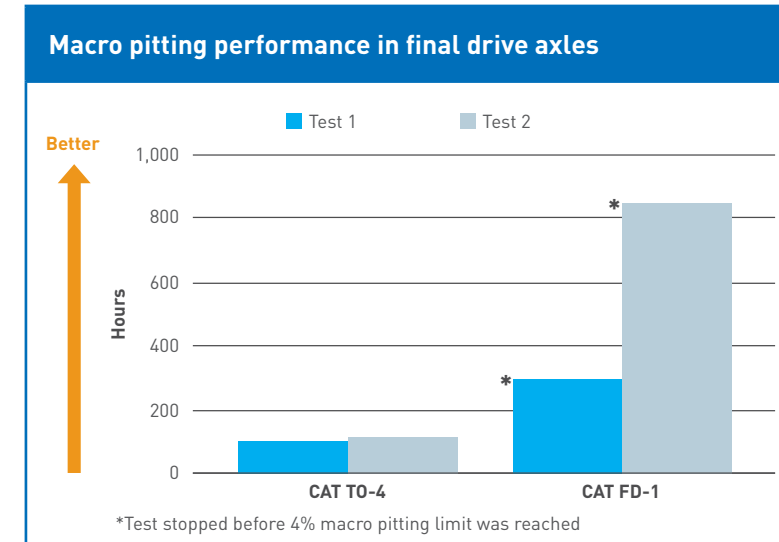

CAT FD-1 oils exhibit improved performance over Transmission Drive Train Oils (TDTO) that meet the CAT TO-4 specification.

In FZG pitting tests, FD-1 oils showed greater than four times the gear macro pitting life of CAT TO-4 oils.

# COOLANTS TO PROTECT ALL TYPES OF COOLING SYSTEMS

Producing an enormous amount of heat, heavy working diesel engines require high levels of cooling system protection and regular maintenance.

Delo® coolants help deliver high performance, reliability and extended service life.

Keeping your engines operating efficiently requires a high performing, extended life coolant – plus a good coolant maintenance programme. Delo XLC Antifreeze/Coolant has a proven track record for high performance.

Delo XLC delivers optimum engine performance and simplifies the way cooling systems are maintained. Our patented corrosion inhibitors help reduce corrosion in cooling system parts, while reducing deposit formation, improving heat transfer throughout their life in your engine.

Compared to conventional coolants, Delo XLC products can help minimise operational cost, while helping to maximise your engine life without the need for supplemental additives.



<b>Delo XLC Antifreeze/Coolant Concentrate, Premixed 50/50, Premixed 40/60</b>	
<b>Extended life antifreeze/coolants</b>	
Product highlights:	
<ul style="list-style-type: none"> <li>Formulated for long, low maintenance service life</li> <li>Offers 8 years or 15,000 hours in off-highway use</li> </ul>	<ul style="list-style-type: none"> <li>Promotes reliability and corrosion protection</li> <li>Contributes to reliable hard water stability</li> <li>Aids high temperature corrosion protection</li> </ul>
<b>Delo XLC PG Antifreeze/Coolant Concentrate</b>	
<b>Extended life Propylene Glycol antifreeze/coolant</b>	
<b>Delo XLI Corrosion Inhibitor Concentrate</b>	
<b>Extended life corrosion inhibitor</b>	

After 21,000+ hours of operation in our Bell articulated mining dump truck, Delo XLC has protected our cooling system against liner pitting, corrosion and scale deposits while operating in very hot and dusty conditions.

Theo Wilcocks  
Technical Manager, Fraser Alexander Mining



# PROTECTION FOR STATIC PLANT AND SPECIALIST EQUIPMENT

Our full suite of Texaco® and Delo® products can be used to cover this wide set of machinery and associated components. The key is to get the right product for the specific application. The people working in our operations and at our distributors are trained to be able to use our support tools to recommend the right product for the job.

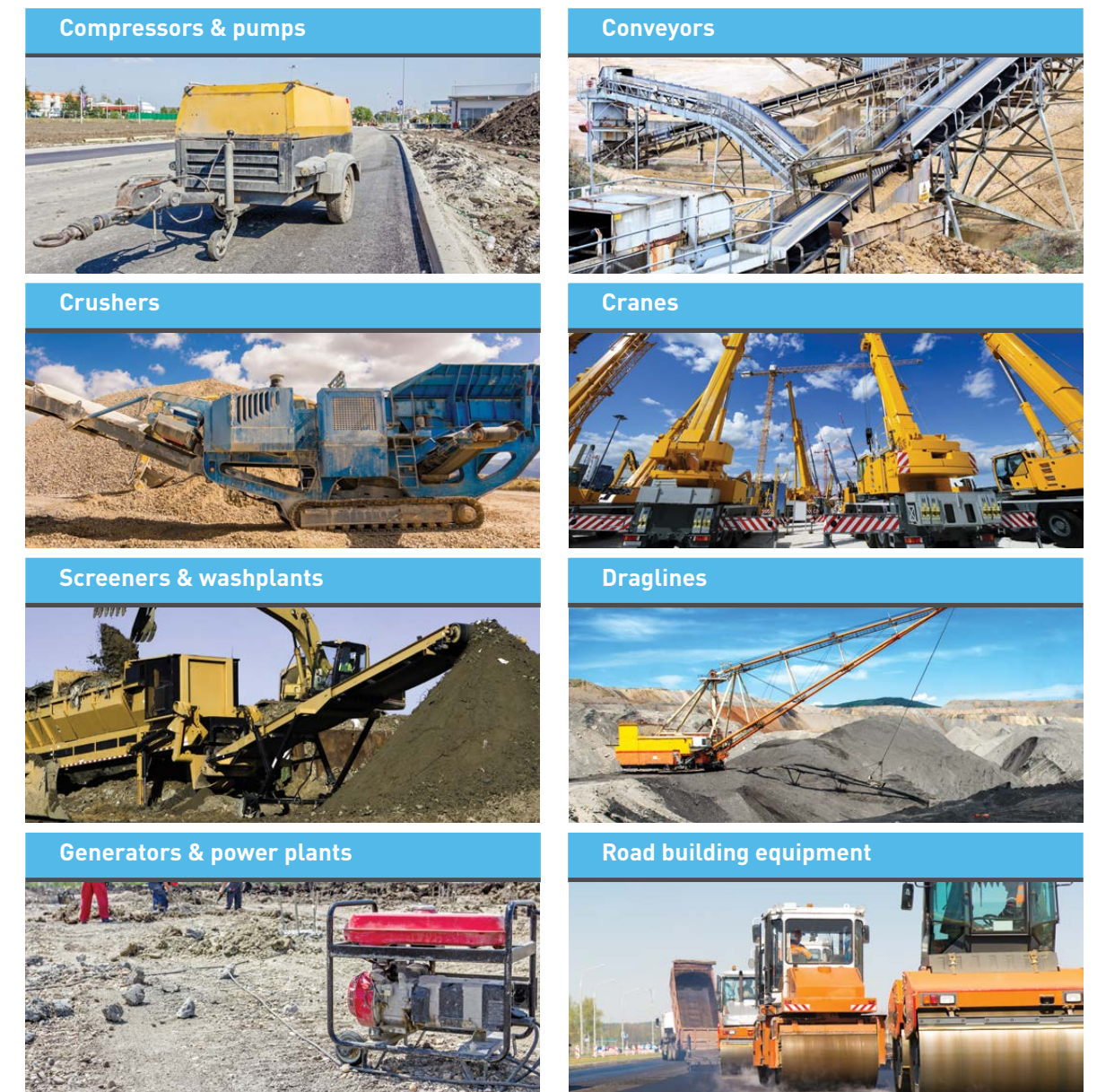

# HEAVY DUTY GREASES FOR MINING, QUARRYING & CONSTRUCTION OPERATIONS

To help your mobile and static equipment go further, it's important that every part operates smoothly. Our Texaco® premium grease products are formulated to provide high performance and long-life protection, across a range of different operational cycles and environments.

<b>Delo Starplex EP 2</b>
Multi-purpose lithium complex grease Product highlights:
<ul style="list-style-type: none"> <li>High thermal resistance</li> <li>Aids long-term wear, corrosion and oxidation protection</li> <li>Mechanically stable</li> <li>Helps protect against dust, dirt and water ingress</li> </ul>
<b>Delo Grease MM EP 2</b>
Extreme pressure multi-purpose lithium grease
<b>Hytex EP 2 LF</b>
Long-service multi-purpose lithium complex grease
<b>Texclad 2</b>
Calcium grease containing Molybdenum Disulphide (MoS <sub>2</sub> ) and Graphite
<b>Texclad AL EP 00/000, EP 0, EP 1, EP 2, HV 0</b>
Aluminium complex greases for high pressure load protection
<b>Molytex EP 2</b>
Multi-purpose heavy duty EP lithium grease containing Molybdenum Disulphide (MoS <sub>2</sub> )
<b>Ulti-Plex Synthetic Grease EP</b>
Synthetic lithium complex grease for continuous high temperature applications
<b>Coupling Grease</b>
Lithium grease with polymer thickener



## Newmont's Nusa Tenggara Mine achieves 18,600+ hours of engine life using Delo® 400 and Delo XLC

PT Newmont Nusa Tenggara (PTNNT) has operated its Batu Hijau copper-gold mine on the Indonesian island of Sumbawa since 2000. The company's fleet of 111 Caterpillar 793 haul trucks runs 24 hours a day, seven days a week, under harsh mining conditions. To protect this significant investment, PTNNT turned to Delo 400 and Delo XLC.

The haul trucks are powered by Cat 3516 engines and typically experience 500-hour oil drains and 12,000-hour coolant service cycles. In late 2011, after 18,600 hours of demanding service, one of the engines was completely stripped down and inspected.

After inspecting and rating all the parts of this engine, it was clear that the Delo family of products were meeting the customer's requirements for engine durability, reliability and reduced operating costs.

We were really impressed with the pristine condition of the engine components after 18,600+ hours of operation.

Andries Smalberger  
Principal Advisor,  
Mine Maintenance,  
PTNNT

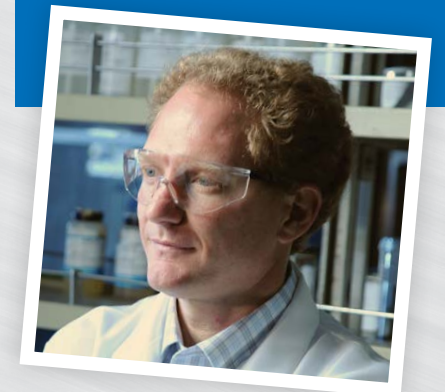

### Piston

Clean ring grooves and minimal deposits on the crown land at 500-hour oil drains.



### Main bearings

Minimal wear and in very good condition after 18,600+ hours of use. No visible copper was showing through the main bearings indicating effective protection provided by Chevron lubricants.



### Piston lining

Almost all of its cross hatching remaining, even after 500-hour oil drains.



### Cam shaft

Minimal wear, no skidding or abrasions. Cam shaft is in such good condition it could be reused again.



# BEST-IN-CLASS TOOLS AND SERVICES FOR MINING, QUARRYING & CONSTRUCTION OPERATIONS

## Chevron reliability

The RBL Programme is our commitment of business support and reliability – Chevron’s lubrication expertise combined with superior products and a tailored service programme work together to help your business.



## Best in Class assessments

Through our RBL Programme, Chevron lubrication specialists who understand off-highway equipment can conduct an assessment of your current lubrication programme to help identify areas for improved performance compared to industry-best peers.

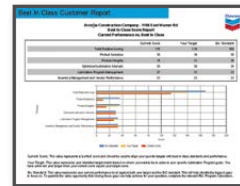

## LubeWatch used oil analysis

Chevron’s premier programme incorporates standardised lubricant sampling and unique online tools to help ensure optimised equipment drain intervals and performance checks to ensure long equipment life.

**LubeWatch®**  
Oil Analysis Program

## Coolant maintenance kit

This kit helps ensure long life coolant system protection. It provides easy-to-use tools to monitor optimal coolant life along with incorporating helpful coolant knowledge information.



**To find out more about how our products and services can assist you, contact your Texaco® Representative, your Authorised Texaco Lubricants Distributor or visit [texacodelo.com](http://texacodelo.com)**

**Protection from bumper-to-bumper. That’s the plus that comes with Delo®.**

At Chevron you could say R&D is in our DNA. We are constantly striving to improve the way our Delo family of products protect and perform. We stand with confidence behind our lubrication products with a bold bumper-to-bumper warranty you won’t find from most manufacturers.

[texacodelo.com](http://texacodelo.com)



The products featured are shortlisted. There is a full suite of Texaco® products that can tailor to customers' needs. Not all products featured are available in your market. Check with your local Texaco sales representative to find out more. Always check OEM requirements when making changes and utilise used oil analysis for extended oil drain intervals.



A Chevron company product

© 2019-2020 Chevron. All rights reserved.  
All trademarks are the property of Chevron Intellectual Property LLC or their respective owners.

DEL024-2hc [08/20]