

Data Sheet

2018 v1.0

SDM120CT-MBus DIN Rail Power Meter

- MID B & D Approved
- Dual Pulsed Outputs
- 5A CT Operated
- 1 Module Dinrail Mounted 35mm (17.5mm Wide)
- MBus Comms



SDM120CT-MBus-MID Single Phase Multifunction Meter

The SDM120CT-MBus Digital Power Meter works in conjunction with a 5A Current Transformer.

Unlike other alternatives, this meter is housed in a 1 Module DIN rail case, meaning it takes up very little space.

The SDM120CT-MBus measures Voltage, Current, Frequency, Power Factor, Max Demand Power, Active Power, Reactive Power, Apparent Power, Total Active Energy, Import Active Energy and Export Active Energy.

Dimensions

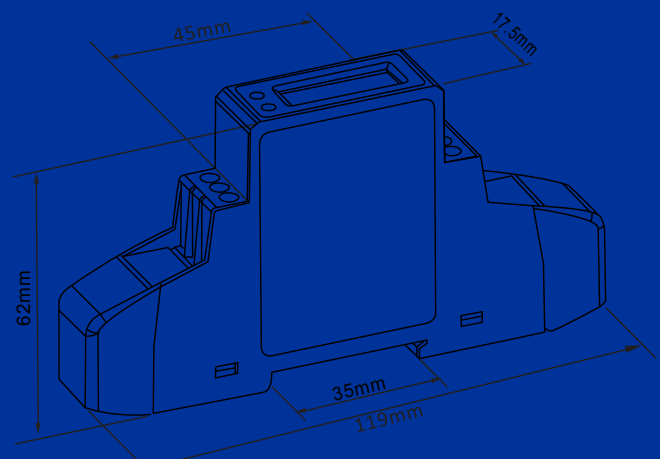

Safety Instructions

The following safety instructions apply to all versions of the SDM120CT range of power meters:

Information for your own safety

This manual does not contain all of the safety measures for operation of the equipment (module, device) because special operating conditions, and local code requirements or regulations may necessitate further measures. However, it does contain information which must be read for your personal safety and to avoid material damages. This information is highlighted by a warning triangle and is represented as follows, depending on the degree of potential danger.

Qualified personnel

Operation of the equipment described in this manual may only be performed by qualified personnel. Qualified personnel means a person who has been authorised to commission, start up, ground and label devices, systems and circuits according to Safety and Regulatory standards.

Use for the intended purpose

The equipment must only be used for the application specified in the datasheet and the user manual.

Proper handling

The prerequisites for reliable operation of the product are proper transport, storage, installation and assembly, as well as proper operation and maintenance. When operating electrical equipment, certain parts of the equipment automatically carry dangerous voltages. Improper handling can therefore result in serious injuries or material damage. Use only insulating tools. Do not connect while circuit is live (hot). Place the meter only in dry surroundings. Do not mount the meter in an explosive area or expose the meter to dust, mildew and insects. Make sure the used wires are suitable for the maximum current of this meter. Make sure the AC wires are connected correctly before activating the current/voltage to the meter. Do not connect the meter to a 3 phase - 400VAC - network. Do not touch the meter connecting clamps directly with your bare hands, with metal, blank wire or other material as you may get an electrical shock. Make sure the protection cover is placed after installation. Installation, maintenance and repair should only be done by qualified personnel. Never break the seals and open the front cover as this might influence the functionality of the meter, and will void any warranty. Do not drop, or allow physical impact to the meter as there are high precision components inside that may break.

SDM120CT-MBus-MID Digital Power Meter - Single Phase

Measured Parameters

The SDM120CT-MBus monitors and displays Total, Imported, Exported and Partial Active Energy (kWh) as well as Instantaneous Active Power (kW) of a single phase two wire (1p2w) system.

Technical Data

Certification	MID B&D Approved
Operating Humidity	≤ 75%
Storage Humidity	≤ 95%
Operating Temperature	-20°C - +50°C
Storage Temperature	-30°C - +70°C
International Standard	IEC 62053-21
Accuracy Class	1
Mounting	DIN rail (DIN 43880)
Sealing	IP51 Indoor
Nominal Voltage Input	(Ph+N) 230V AC (176-276V AC)
Max Continuous Voltage	120% of nominal
AC Voltage Withstand	4KV for 1 minute
Impulse Voltage Withstand	6KV-1.2μS
Current Input	0.25-5A(6)A AC RMS
Operational Current Range	0.4% I _b -I _{max}
Over current withstand	20I _{max} for 0.01s
Nominal Input Current Burden	0.5VA
Frequency	50Hz(±10%)
Power Consumption	≤ 2W/10VA/phase
Pulsed Output	1000imp/kWh

Accuracy

Voltage, Current	0.5%
Frequency	0.2% of Mid-Frequency
Power Factor	1% of Unity (0.01)
Active Power, Apparent Power	≤ 1% of Range Maximum
Reactive Power	≤ 1% of Range Maximum
Reactive Energy (Varh)	Class 2
Active Energy (Wh)	Class 1

Modbus

Bus Type	RS485 (Semi-Duplex)
Protocol	Modbus RTU
Baud Rate	1200/2400/4800/9600bps
Address Range	1-247
Max. Bus Loading	64pcs
Communication Distance	1000 Meters
Parity	EVEN/ODD/NONE
Data Bit	8
Stop Bit	1

M-bus

Bus Type	M-bus
Protocol	EN13757-3
Baud Rate	300/600/1200/2400/4800/9600
Parity	EVEN/ODD/NONE
Stop Bit	1 or 2
Primary Address	1 to 250
Secondary Address	00 00 00 01 to 99 99 99 99

Wiring Diagram

