

M2 Flat Head Cap Machine Screws (FHCS)

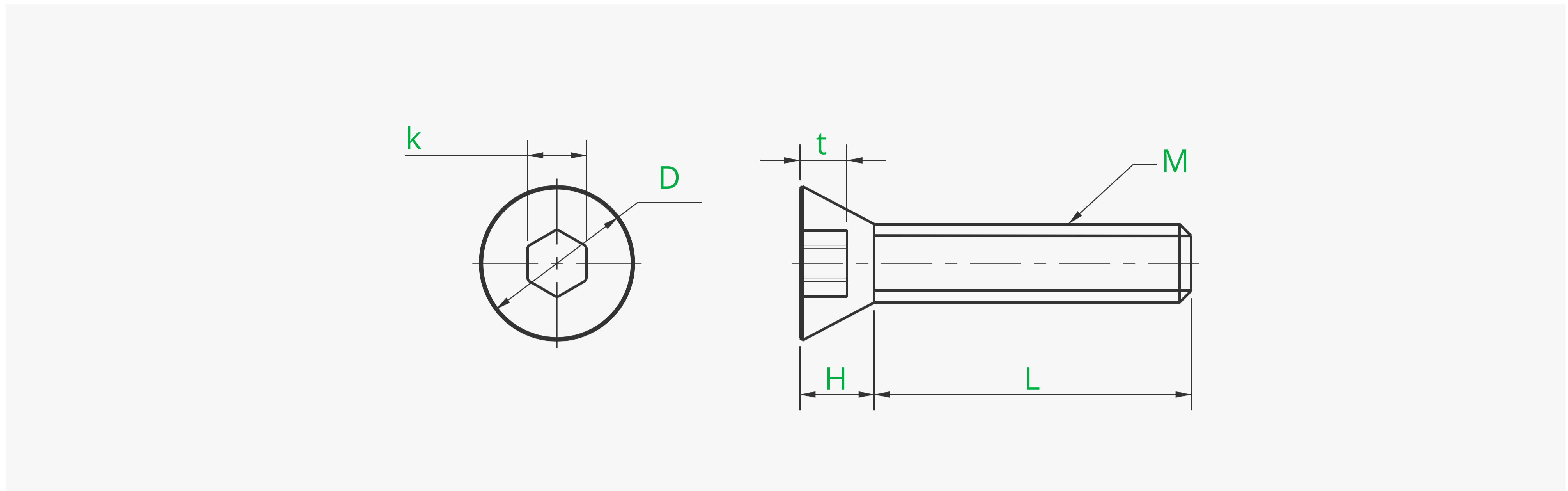

Product ID	M (mm) Nominal Diameter	P (mm) Thread Pitch	L (mm) Bolt Length	D (mm) Head Diameter	H (mm) Head Thickness	k (mm) Hexagon Across Flats	t (mm) Groove Depth	Screwdriver Bit Size
AA009	2	0.4	6	4	1.9	1.5	1.2	H1.5
AA011	2	0.4	8	4	1.9	1.5	1.2	H1.5
AA007	2	0.4	10	4	1.9	1.5	1.2	H1.5
AA015	2	0.4	12	4	1.9	1.5	1.2	H1.5
AA017	2	0.4	14	4	1.9	1.5	1.2	H1.5

Compliant with the requirements of GB/T 70.2-2015 standard [Equivalent standards: ISO 7380-1, DIN EN ISO(-1)]

Basic Information

Surface Treatment	No	Material	Stainless steel
Mounting Hole Shape	Hex socket	Thread Ridge Type	Metric coarse
Screw Type	Complete thread	Color	Silver

Product Feature

- Stainless Steel Flat Head Cap Machine Screws (FHCS)
- Nominal thread: M2.5~M5
- Strength grade: 4.8
- Type of thread: Metric coarse thread (currently all screws are metric coarse thread)
- Full thread series (except M3*23)

M2 沉头机牙螺丝

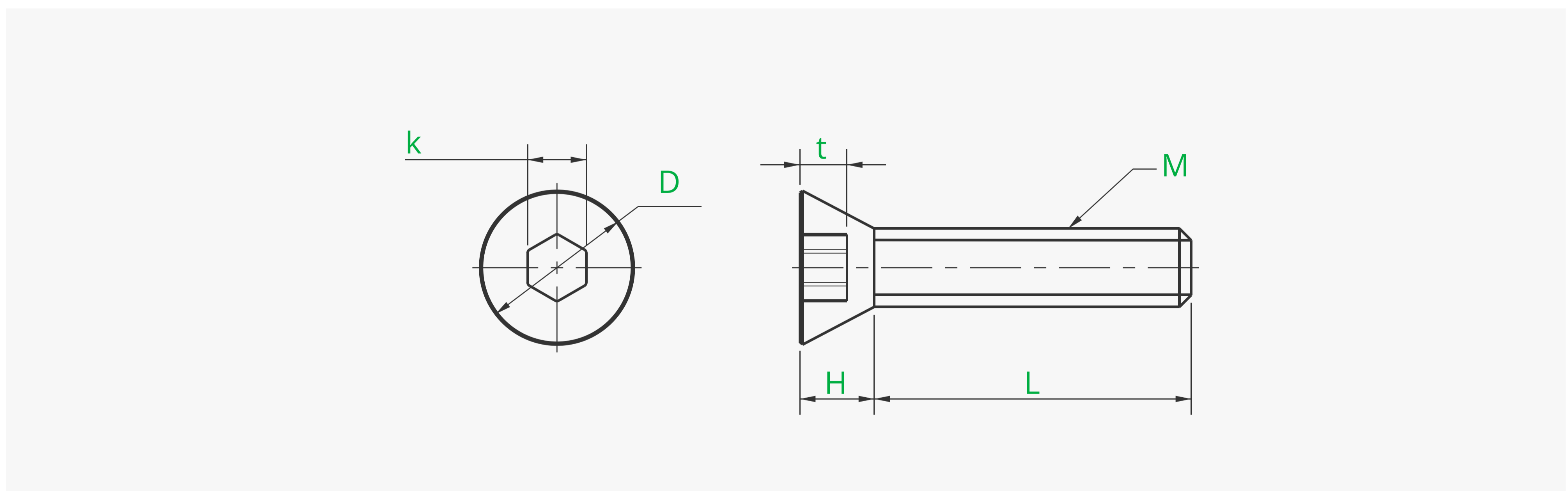

产品 ID	公称直径M (mm)	螺距P (mm)	螺栓长度L (mm)	头部直径D (mm)	头部厚度H (mm)	六角对边距k (mm)	槽深t (mm)	适配批头
AA009	2	0.4	6	4	1.9	1.5	1.2	H1.5
AA011	2	0.4	8	4	1.9	1.5	1.2	H1.5
AA007	2	0.4	10	4	1.9	1.5	1.2	H1.5
AA015	2	0.4	12	4	1.9	1.5	1.2	H1.5
AA017	2	0.4	14	4	1.9	1.5	1.2	H1.5

符合GB/T 70.2-2015标准要求 [等效标准: ISO 7380-1, DIN EN ISO(-1)]

基本信息

表面处理	无	材质	不锈钢
批头种类	内六角	螺纹牙形	公制 粗牙
牙长	全螺纹型	表面颜色	银色

产品特点

- 不锈钢沉头机牙螺丝
- 螺纹公称: M2.5~M5
- 强度等级: 4.8
- 全牙系列 (除M3*23)
- 螺纹牙形种类: 公制粗牙 (目前所有的螺丝都为公制粗牙)