

# HM327BKS

Group **27**  
Batteries

## Snap-Top Battery Box™



Side View



Exploded View

**Impact, UV, And Contaminant Resistant. Fully Ventilated To Release Gases.**

All NOCO battery boxes meet US Coast Guard Code (USCG) of Federal Regulations.

Extremely rugged, structural reinforced battery boxes that provide uncompromising protection for any battery application. Manage your marine, RV, trailer, or stored batteries with ease of mind, knowing that the batteries are protected from any outside contaminants, and the internal reservoir makes sure anything on the inside, stays inside.

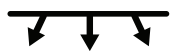

**IMPACT**  
Resistant

Designed with an engineered polymer that maintains its impact properties down to -20 degrees Fahrenheit.

**UV**

Resistant

Designed with UV inhibitors and color stabilizers to prevent structure degradation, and color fading.

Made In  
**USA**

We strive to create only the best. Every NOCO battery box is designed, engineered, and made in the USA.

Ventilated  
**SAFE**  
SECURE

Meets the USCG Code of Federal Regulations 183.420 and the ABYC's E-10.7 code requirements.

**Snap-Top** Battery Boxes Were Designed For Groups: U1, 24, 24-31, 27 & 6-Volt

The NOCO Company  
30339 Diamond Parkway, #102  
Glenwillow, OH 44139 | USA  
1.800.456.6626

no.co

**NOCO**  
Since 1914

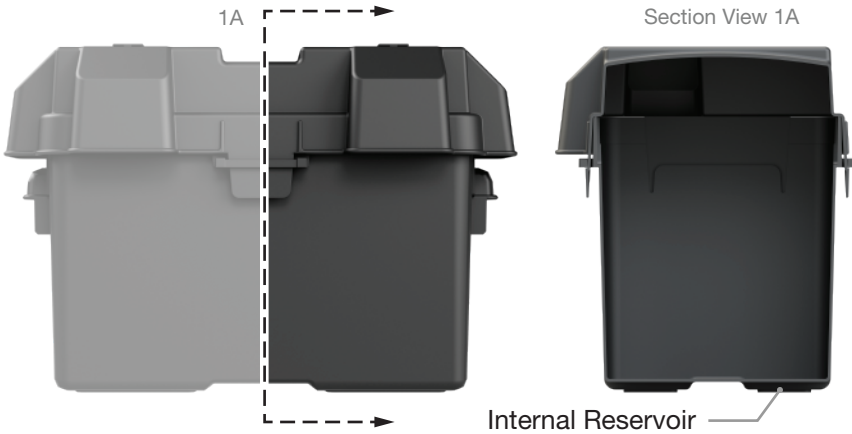
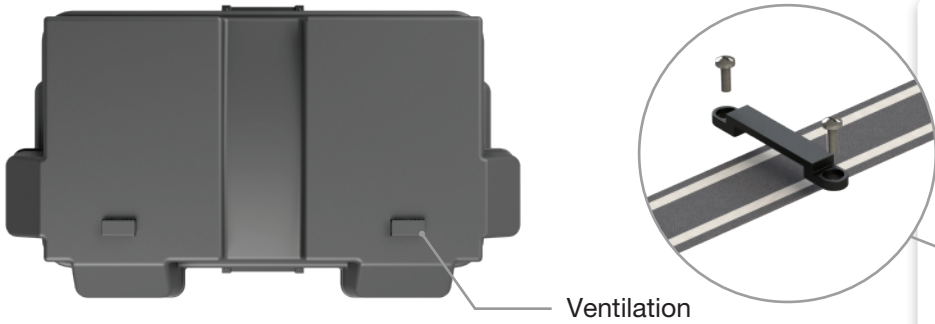

**Ventilation.**

When a battery is presented with a high enough charge, the internal chemicals will begin to give off hydrogen gas. This gas can be dangerous when it is concentrated. NOCO's battery boxes all have proper ventilation, allowing for gases to escape. Along with removable rain guards, this allows the gas to escape without getting water inside.

**Internal Reservoir.**

Should there ever be an event where the structural integrity of the battery inside a NOCO battery box is weakened, the internal reservoir will collect any excess liquid, protecting the surrounding environment.

**About Coast Guard Regulations.**

The US Coast Guard maintains strict regulations on the storage of batteries. Batteries on-board boats must **not move more than one inch** in any direction surrounding the battery and only one inch in the vertical direction.

**Battery Size Specifications**

Min. Size:	11.2 (L) x 5.2 (W) x 8.1 (H) in.
Max. Size:	13.2 (L) x 7.2 (W) x 10.1 (H) in.

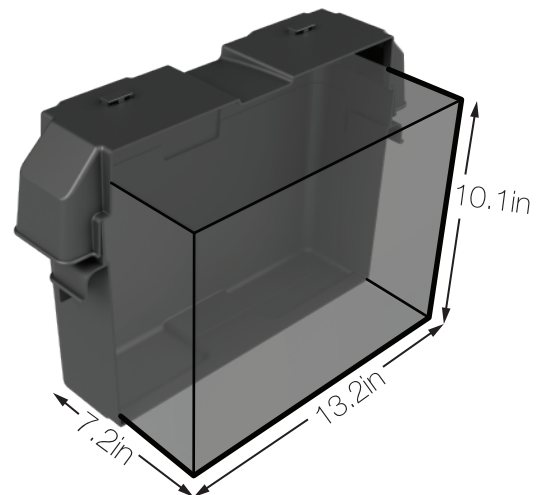
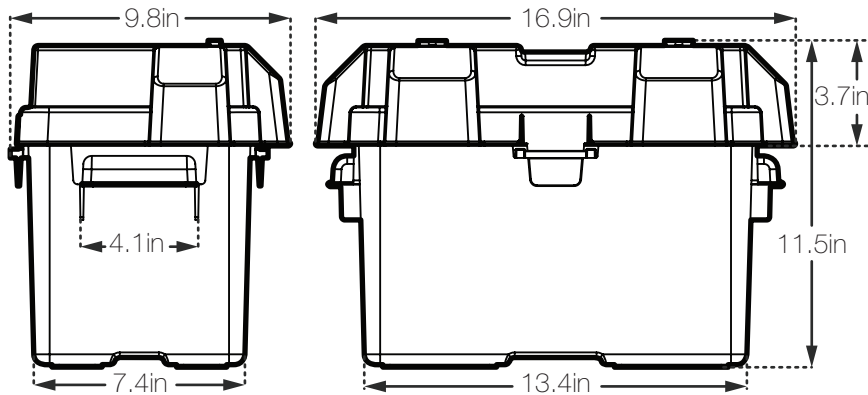

Internal capacity.

**Technical Specifications**

What's Included:	Battery Box, 42in. Strap, Hardware
Battery Size:	Group 27
Internal Cargo Dimensions:	13.2 (L) x 7.2 (W) x 10.1 (H) in.
External Dimensions:	16.9 (L) x 9.8 (W) x 11.5 (H) in.
Product Weight:	4.0 lbs (64 oz)