

RELi³ON[®]

INSIGHT SERIES MANUAL



insight[™]
SERIES

TABLE OF CONTENTS

1. Introduction	3	13. BMS Protection Details	10
2. Scope	3	13.1. Under Voltage Protection (UVP)	10
3. Abbreviations	3	13.2. Over Voltage Protection (OVP)	10
4. Product Specifications	3	13.3. Under Temperature Protection (UTP)	11
4.1. General Specifications	3	13.4. Over Temperature Protection (OTP)	11
4.2. Electrical Specifications	4	13.5. Over Current Protection (OCP)	11
4.2.1. Charging Specifications	4	13.6. Short Circuit Protection (SCP)	11
4.2.2. Discharging Specifications	4	14. CANbus Communication	11
4.2.3. Parallel Specifications	5	14.1. CAN Connectors	11
4.3. Mechanical Specifications	6	14.2. Communication Hardware	12
4.4. Drawing	6	14.3. CANbus Details	12
5. Battery Installation	6	14.4. Broadcast Data	12
5.1. Parallel Connections	7	14.5. Broadcast Data Frame	12
5.2. Battery Orientation	7	15. Charging Guidelines	12
6. Battery Interface	7	15.1. Charger Inspection	12
6.1. Power Button	7	15.2. Charge Temperature	12
6.2. LEDs	8	15.3. Prior to Charge	12
7. Battery Mode Descriptions	8	15.4. During Charge	13
8. Power Button Functions	8	15.5. Charge Completion	13
9. LED Function 1 – Battery Status	8	15.6. Charge Parameters	13
10. LED Function 2 – SOC Status	9	15.6.1. CC Charge Profile – 1 Stage	13
11. LED Function 3 – Protection/Error Indicators	9	15.6.2. CC-CV Charge Profile – 2 Stage	13
12. Battery Mode Operation Details	9	16. Battery Indicator	14
12.1. OFF Mode	9	17. Battery Storage	14
12.2. ON Mode	9	18. Energy Consumption During Storage	14
12.3. SLEEP Mode	9	19. Recycling	15
12.3.1. Pulse Recovery Operation (PRO) During SLEEP Mode	9	20. Warranty Registration	15
12.4. Under Voltage Protection (UVP) Mode	10	21. Precautions	15
12.4.1. Pulse Recovery Operation (PRO) During UVP Mode	10		
12.5. Turn Battery ON During PRO	10		

1. INTRODUCTION

RELiON's InSight Series batteries are the first scalable LiFePO₄ drop-in replacement battery, that comes in an industry standard, GC2 size.

2. SCOPE

This document applies to models:

48V030-GC2

24V060-GC2

12V120-GC2-LT

3. ABBREVIATIONS

- State of Charge (SOC)
- State of Health (SOH)
- Over Voltage Protection (OVP)
- Under Voltage Protection (UVP)
- Over Temperature Protection (OTP)
- Under Temperature Protection (UTP)
- Over Current Protection (OCP)
- Short Circuit Protection (SCP)
- Light Emitting Diode (LED)
- Pulse Recovery Operation (PRO)
- Controller Area Network bus (CANbus)
- Battery Display Indicator (BDI)
- Low Temperature (LT)

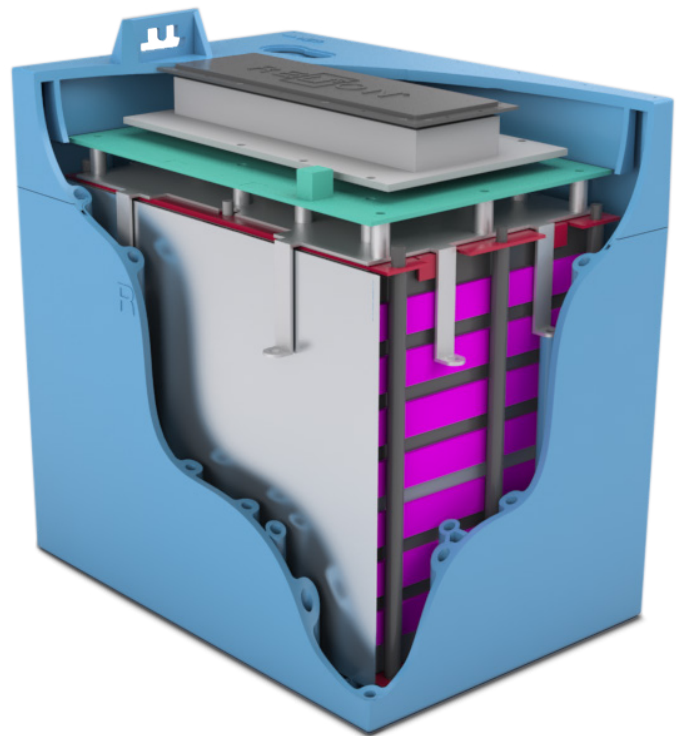

4. PRODUCT SPECIFICATIONS

4.1. General Specifications

GENERAL SPECIFICATIONS			
Model	48V030-GC2	24V060-GC2	12V120-GC2-LT
Nominal Voltage	51.2V	25.6V	12.8V
Cell Chemistry	LiFePO4	LiFePO4	LiFePO4
Cell Type	Prismatic	Prismatic	Prismatic
Ampere-hour Capacity	30Ah	60Ah	120Ah
Watt-hour Capacity	1.536kWh	1.536kWh	1.536kWh
Specific Energy	128Wh/kg	128Wh/kg	128Wh/kg
Charge Efficiency	99%	99%	99%
Impedance (50% SOC, 1kHz)	<150mΩ	<150mΩ	<100mΩ
Cycles @ 80% DOD	>3500	>3500	>3500

4.2. Electrical Specifications

4.2.1. Charging Specifications

CHARGE SPECIFICATIONS			
Model	48V030-GC2	24V060-GC2	12V120-GC2-LT
Recommended Continuous Charge Current (single battery)	≤60A	≤60A	≤60A
Maximum Charge Current (BMS will disconnect if exceeded)	65A - 5 sec	65A - 5 sec	100A - 5 sec
Recommended Charge Voltage	57.6 - 58.4V	27.6V	14.4-14.6V
Maximum Charge Voltage	58.4V	29.2V	14.6V
Float Voltage	54.4V	27.2V	13.8V
High Voltage Disconnect	59.2V (3.7vpc) (4 sec)	29.6V (3.7vpc) (4 sec)	14.8V (3.7vpc) (4 sec)
Over Voltage Reconnect	Automatic	Automatic	Automatic
Minimum Charger Output Voltage (for charge initiation)	56V	28V	14V
Temperature Compensation Required	None	None	None

4.2.2. Discharging Specifications

DISCHARGE SPECIFICATIONS			
Model	48V030-GC2	24V060-GC2	12V120-GC2-LT
Continuous Discharge Current	100A	100A	160A
Peak Discharge Current	200A (15 sec)	240A (15 sec)	400A (5 sec)
Short Circuit Protection	560A (366 μsec)	880A (366 μsec)	3000A (300 μsec)
Low Voltage Disconnect	40V (2.5vpc) (5 sec)	20V (2.5vpc) (5 sec)	10V (2.5vpc) (5 sec)
Low Voltage Reconnect	See section 12.5	See section 12.5	See section 12.5

4.2.3. Parallel Specifications

All the currents are additive in Parallel operation. See tables below.

48V030-GC2

CHARACTERISTIC	48V X 1	48V X 2	48V X 3	48V X 4
Voltage	51.2V	51.2V	51.2V	51.2V
Capacity	30Ah	60Ah	90Ah	120Ah
Cont. Discharge Current	100A	200A	300A	400A
Peak Discharge (15 sec)	200A	400A	600A	800A
Max. Charge Current	60A	90A	135A	180A

24V060-GC2

CHARACTERISTIC	24V X 1	24V X 2	24V X 3	24V X 4
Voltage	25.6V	25.6V	25.6V	25.6V
Capacity	60Ah	120Ah	180Ah	240Ah
Cont. Discharge Current	100A	200A	300A	400A
Peak Discharge (15 sec)	240A	480A	720A	960A
Max. Charge Current	60A	90A	135A	180A

12V120-GC2-LT

CHARACTERISTIC	12V X 1	12V X 2	12V X 3	12V X 4
Voltage	12.8V	12.8V	12.8V	12.8V
Capacity	120Ah	240Ah	360Ah	480Ah
Cont. Discharge Current	160A	320A	480A	640A
Peak Discharge (5 sec)	400A	800A	1200A	1600A
Rec'd. Charge Current	60A	90A	135A	180A
Peak Charge Current (5 sec)	100A	150A	225A	300A

*When using more than one battery in parallel, we recommend limiting both continuous and peak currents to 75% of the specification. For example, if using 2, 48V030-GC2 batteries in parallel, do not exceed 150A continuous and 300A peak currents. This is to avoid the potential of a battery going into protection mode.

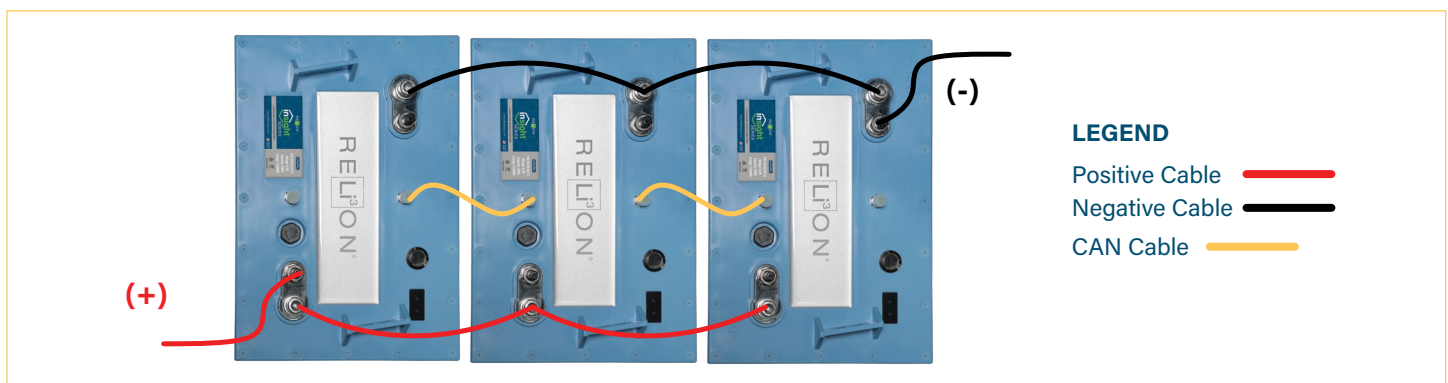

4.3. Mechanical Specifications

MECHANICAL SPECIFICATIONS			
Model	48V030-GC2	24V060-GC2	12V120-GC2-LT
BCI Size	GC2		
Dimensions (L x W x H)	10.2 x 7.1 x 10.9 in (260 x 180 x 276 mm)		
Weight	34.4 lb. (15.6 kg)		
Case Material	ABS		
Stud Terminal	M8 X 1.25 - 20		
Insert Terminal	M8 X 1.25 - 20		
Torque	79.7-88.5 in-lbs. (9-10 N-m)		
Handles	Molded		
Ingress Protection Marking	IP67		
Case Flame Rating	UL94 V-0		

4.4. Drawing

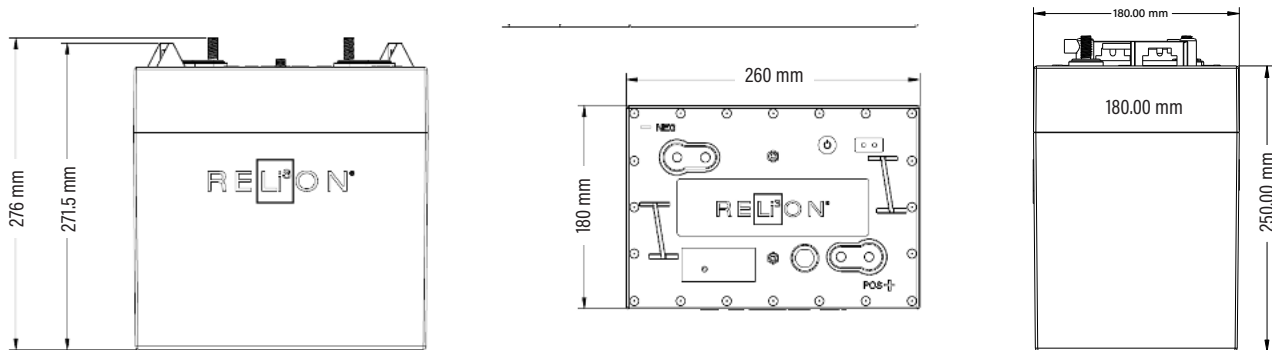

Dimensions shown in mm

5. BATTERY INSTALLATION

To ensure proper operation of the battery (for single-battery or multiple-battery installations), follow the steps below:

- InSight batteries can only be used in parallel (not series). Up to 10 batteries may be connected.
- Select proper wire gauge for your applications electrical current (A) demands (Suggested reference: NEC 2014: Table 310.15(B)(17) Allowable Ampacities of Insulated Conductors).
- On new installations it is recommended that new battery cables (free from corrosion) be used.
- Ensure that all battery cables are equal in length to avoid battery imbalances. CAUTION : Any existing 12V accessories (lights, radio, etc) must be connected to an auxiliary DC/DC converter (48V to 12V or 24V to 12V)
- All cables should terminate at bus bars with respect to their polarity.
- Torque the battery terminals appropriately as listed in Section 4.3.
- Connect the provided Controller Area Network bus (CANbus) cables as shown in Section 5.1.
- Turn batteries ON. See the table in Section 8 or Section 12.2 for written instructions.
- Charge the batteries to 100% State of Charge (SOC) prior to use.

5.1. Parallel Connections – Options 1 and 2

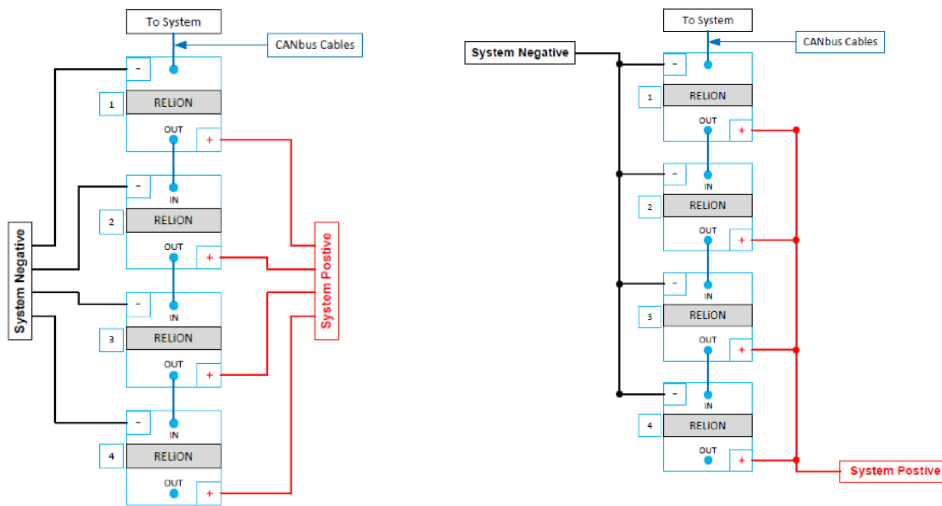

5.2. Battery Orientation

The best way to install the battery is upright as the bottom of the case is flat. The battery can be placed in the following orientations:

- Upright
- Short sides – either side
- Long side – only with positive side up

DO NOT INSTALL the battery on the long side with the negative side up as this can put stress on the internal connections causing damage that may result in battery failure.

- Do not install batteries in a zero-clearance compartment, overheating may result. Always leave at least 4" of space around all sides and top of battery
- Keep any flammable/combustible material (e.g., paper, cloth, plastic, etc.) that may be ignited by heat, sparks, or flames at a minimum distance of two feet away from the batteries
- Battery compartment and any material within two feet should be noncombustible.

6. BATTERY INTERFACE

6.1. Power Button

The battery has a button located next to the LED display that is used to:

- Turn the battery ON/OFF/RESET
- Request the battery SOC

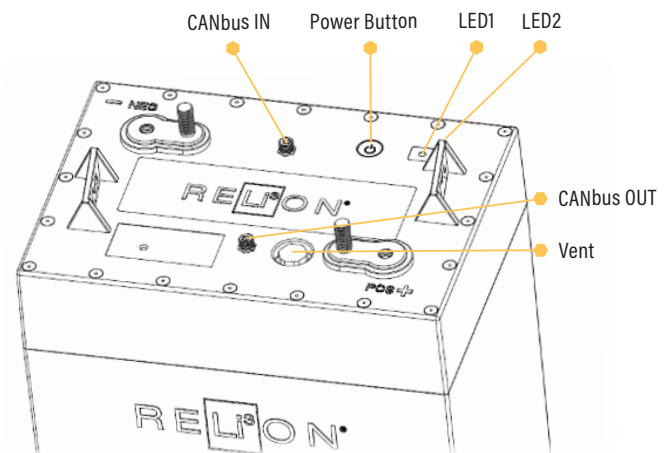

6.2. LEDs

The battery has two tri-colored LED lights on the cover (green, yellow, and red) that are used to communicate:

- Battery Status
- Battery SOC
- Battery Protection/Error Status

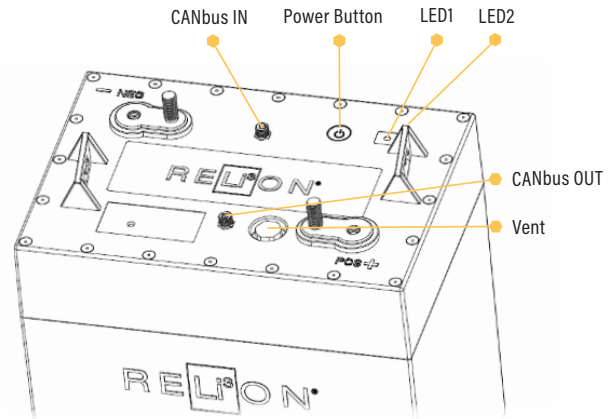

7. BATTERY MODE DESCRIPTIONS

MODE	DESCRIPTION
OFF	Battery is OFF
ON (Active)	Battery is ON and being charged/discharged
ON (Standby)	Battery is ON and Idle
SLEEP	Battery is cycling ON/OFF intermittently
PROTECTION	BMS has disconnected voltage/current from terminals

8. POWER BUTTON FUNCTIONS

ACTION	OPERATION	REMARKS
Power ON	<i>Press and hold</i> button for 5s until: <ul style="list-style-type: none"> • LED1 Flashes Green • Then release button 	Battery will turn ON
Display SOC	<i>Tap</i> button once	LED displays for 6 sec. See section 10: SOC Status
Power OFF	<i>Tap, release, then press and hold</i> button for 6s until: <ul style="list-style-type: none"> • LED1 Solid Red • LED2 Solid Red • Then release button 	Battery will turn OFF
Reset BMS	<i>Tap, Press and hold</i> button for >2s until: <ul style="list-style-type: none"> • LED1 is Solid Red • LED2 is Solid Green • Then release button 	<ul style="list-style-type: none"> • BMS program restart • SOC level re-calculate • Pack input/output close and open again
Wake Up from Sleep	<i>Tap</i> button twice	Initiates 1 min. charge pickup window
Wake Up from UVP	<i>Tap</i> button twice	Initiates 1 min. charge pickup window

9.LED FUNCTION 1 - BATTERY STATUS

MODE	LED 1	LED 2
OFF	Off	Off
ON (Active)	Flashing Green (every 5 sec.)	Off
ON (Standby)	Flashing Green (every 5 sec.)	Off
Charging	Off	Flashing Green (every 2 sec.)

10. LED FUNCTION 2 - SOC STATUS (INITIATE WITH A SINGLE TAP OF THE POWER BUTTON)

SOC	LED 1	LED 2
95% - 100%	Solid Green	Solid Green
75% - 95%	Solid Green	Flashing Green (every ½ sec.)
50% - 75%	Solid Green	Solid Yellow
30% - 50%	Solid Green	Flashing Yellow (every ½ sec.)
10% - 30%	Solid Green	Solid Red
0 - 10%	Solid Green	Flashing Red (every ½ sec.)

11. LED FUNCTION 3 - PROTECTION/ERROR INDICATORS

MODE	LED 1	LED 2
Under Voltage Protection	Flashing Red (every 5 sec.)	Off
Over Discharge Current Protection	Solid Green	Solid Yellow
Temperature Protection	Flashing Green (every sec.)	Flashing Red (every sec.)

12. BATTERY MODE OPERATION DETAILS

12.1. OFF Mode

The battery ships in the OFF mode. There is no LED activity and voltage is not present at the terminals. To turn the battery OFF: Tap the button once, release, then press the button again holding for 6 seconds until you see both LEDs display solid red lights then release the button. This action will turn off both LEDs.

12.2. ON Mode

To turn the battery on press button for 5 seconds. LED1 will flash green every 5 seconds.

- **ON (Active)** - The battery is in ACTIVE mode only while being charged or discharged. The minimum charge current for active mode is 0.5A (2s). The minimum discharge current for active mode is 0.8A (1s).
- **ON (Standby)** - STANDBY mode is any time the battery is ON and not being discharged or charged. When a battery is in STANDBY mode, voltage is present at the terminals. If it is charged or discharged during STANDBY mode it will return to ACTIVE mode. If a battery is sitting in STANDBY mode continuously for more than 72 hours (24 hours for 12V battery) it will enter SLEEP mode.

12.3. SLEEP Mode

The battery will go into SLEEP mode if it is in STANDBY mode for more than 72 hours (24 hours for 12V battery) without being discharged or charged. The LEDs will not be illuminated.

The battery will go into a Pulse Recovery Operation (PRO) while in SLEEP mode.

12.3.1. Pulse Recovery Operation (PRO) During SLEEP Mode

The purpose of Pulse Recovery Operation is to place the battery in a low power state in order to preserve its energy. The battery will cycle between the OFF and ON (Standby) modes as follows:

- The battery will turn ON (Standby) for 1 minute every 10 minutes. LED1 will flash green every 0.5 seconds when the battery is ON for 1 minute.

12.4. UNDER VOLTAGE PROTECTION (UVP) Mode

If the battery voltage reduces to less than 40.0V for a 48V model, or 20.0V for a 24V model, or 10.0V for a 12V model, or any individual cell reduces to less than 2.5V, the battery will go into UVP protection mode. LED1 will flash RED every five (5) seconds.

The battery will go into a Pulse Recovery Operation (PRO) in UVP mode.

12.4.1. Pulse Recovery Operation (PRO) During UVP

The purpose of Pulse Recovery Operation is to place the battery in a low power state in order to preserve its energy. The battery will cycle between the OFF and ON (Standby) modes as follows:

- Day 1: The battery will turn ON (Standby) for 1 minute every 10 minutes. LED1 will flash green every five (5) seconds for 1 minute then return to flashing red once every five (5) seconds until next interval. (As shown below the OFF interval increases by 10 minutes each day).
- Day 2: The battery will turn ON (Standby) for 1 minute every 20 minutes.
- Day 3 to 24: The duration of the OFF phase will increase by 10 minutes every 24hrs and the duration of the ON phase will remain at 1 minute.
- Day 25: The battery will turn itself OFF indefinitely. The battery must be turned ON as described in Section 12.2.

12.5. Turn Battery ON during PRO

- Connect a compatible battery charger to the battery. During the 1-minute ON (Standby) phase in Pulse Recovery Operation the battery will return to ON (Active) mode.
- The 1 minute ON phase can also be triggered manually by tapping the button twice. A compatible battery charger must then be connected before the battery turns OFF.

13. BMS PROTECTION DETAILS

13.1. Under Voltage Protection (UVP)

LED1 - Flash Red (every 5 seconds), LED2 - Off

This mode protects the battery from reaching a low voltage level that can damage the battery. If the battery voltage reduces to less than 40.0V for a 48V model or 20.0V for a 24V model, or any individual cell reduces to less than 2.5V, for five (5) seconds the battery will go into UVP protection mode. The battery will simultaneously be in a PULSE RECOVERY mode as explained above. The methods for recovering the battery from PULSE RECOVERY mode and returning it to ON mode are the same as above. Depending on the cause, the battery may self-recover from UVP if allowed to rest. In the event the battery does not recover, manually initiate recovery as written above. The battery will automatically reconnect when the voltage is $\geq 46.4V$ for a 48V model, or $\geq 23.2V$ for a 24V model, or $\geq 11.6V$ for a 12V model.

13.2. Over Voltage Protection (OVP)

LED1 - Flash Green (every 5 seconds), LED2 - Off

This mode protects the battery from reaching a high voltage level that can damage the battery. If the battery voltage increases to greater than 59.2V for a 48V model, or 29.6V for a 24V model, or 14.8V for a 12V model for four (4) seconds, or any individual cell increases to greater than 3.7V, the battery will go into OVP protection mode. The battery will automatically reconnect if discharged or when the highest cell voltage is $< 3.4V$ and the SOC $< 96\%$.

13.3. Under Temperature Protection (UTP)

LED1 - Flash Green (1 second), LED2 - Flash Red (1 second)

This mode protects the battery from being charged in temperatures below freezing, which can damage the battery. The BMS will not allow charge current when the battery temperature is below freezing (0°C/-32°F). However, the BMS will allow discharge below freezing down to -30°C/-22°F.

13.4. Over Temperature Protection (OTP)

LED1 - Flash Green (every 1 second), LED2 - Flash Red (every 1 second)

This mode protects the battery from reaching high temperatures, which can damage the battery.

- **Charge OTP** - The BMS will disconnect while charging when the battery temperature exceeds 55°C/131°F.
- **Discharge OTP** - The BMS will disconnect while discharging when the battery temperature exceeds 65°C/149°F.

13.5. Over Current Protection (OCP)

LED 1 - Solid Green, LED 2 - Solid Yellow

This mode protects the battery from discharging at excessive levels of current. The maximum current level values for banks of up to four (4) batteries are listed in the Discharge Specification in Section 4.2.2. The maximum current levels are additive and must be calculated for banks of more than 4 batteries.

13.6. Short Circuit Protection (SCP)

LED1 – Solid Green, LED2 – Solid Yellow

This mode protects the battery from discharging at extremely high levels of current. The short circuit current level for a single battery is listed in the Discharge Specification in Section 4.2.2.

14. CANBUS COMMUNICATION

This section provides the basics for CANbus operation and/or integration. For additional details on how to interface to the CANbus and interpret the messages consult the RELiON CANbus Specification Document. Parallel connected InSight batteries communicate internally via CANbus. External communication is available through the CANbus OUT port of the battery. The 12V battery is RV-C compatible (at OEM request) for up to 10 batteries through bridge.

14.1. CAN Battery Connectors: M8-5P

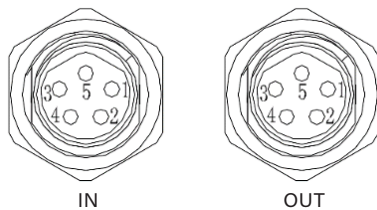

PIN	CAN INPUT BATTERY CONNECTOR (Next to Negative Terminal)	CAN OUTPUT BATTERY CONNECTOR (Next to Postive Terminal)
1	Reserve	Reserve
2	CANbus Address IN	CANbus Address IN
3	CAN-H	CAN-H
4	CAN-L	CAN-L
5	P- (Battery Negative)	P- (Battery Negative)

14.2. Communication Hardware

The batteries do not have 120Ω termination resistors. Up to ten batteries may be read in a single CANbus network.

14.3. CANbus Details

- CAN2.0A
- Identifier: 11-bit
- Broadcast ID: 0x5FF
- Bit Rate: 250kbps
- Multi-Byte value form: Little-Endian

14.4. Broadcast Data

The BMS broadcasts alarms, system status, and SOC every 3 seconds via ID 0x5FF. If an alarm is triggered it will be broadcasted immediately.

14.5. Broadcast Data Frame

ID	DLC	D0	D1	D2
0x5FF	8	0x20	0x81	0x21
D3	D4	D5	D6	D7
0X01	Alarm1	Alarm2	Status	SOC

15. CHARGING GUIDELINES

Follow these charging guidelines to achieve optimal performance and maximum life from your RELION Lithium Iron Phosphate (LiFePO4) InSight battery.

Conventional lead acid chargers can be connected to the InSight battery without concern/harm as the battery BMS will protect the battery against improper charge conditions (*this will not void the warranty*). Please read and exercise the charging practices below to achieve the best results.

15.1. Charger Inspection

Check that your charger's cables are insulated and free of breakage. Charger terminal connectors should be clean and properly mate with the battery terminals to ensure a good connection and optimum conductivity.

15.2. Charge Temperature

LiFePO4 batteries can be safely charged between 0°C to 55°C (32°F to 131°F).

LiFePO4 batteries do not require temperature compensation for voltage when charging at hot or cold temperatures.

The InSight Series batteries come with a BMS that protects the battery from over-temperature. If the BMS disconnects due to high temperature, wait until the temperature reduces before using or charging the battery. Please refer to your specific battery's Data Sheet for the BMS high temperature cut-off and reconnect values.

15.3. Prior to Charge

- It is best to use/select a Lithium, GEL or AGM charge profile in that order of availability. Consult your manual or charger manufacturer for directions on this capability. Some charger models only have the stock charge profile available.
- Spot check the battery SOC LED indicators with a quick press and release of the battery Power Button. See the table in Section 10 to determine the SOC.

15.4. During Charge

- Check if charge current is being supplied in one of the following ways:
 - Battery LED indicators: The proper LED sequence be displayed: LED1 – Off, LED2 – flashing green (every 2 seconds).
 - RELiON Battery Display Indicator (BDI): Spot check the accessory gauge to see if charge current is flowing and battery SOC percentage increasing
 - Digital Voltmeter w/amp clamp (DVM): Spot check the accessory gauge to see if charge current is properly flowing.

15.5. Charge Completion

- The Charger’s behavior at the end of a Lithium battery recharge may vary from the standard operation consistent with charging lead-acid batteries.
- Chargers typically display a solid Green Light when the charge is completed, and a flashing green light when the battery is near the end of charge (will vary by charger). Both conditions may or may not occur depending on your charger design. Neither condition is necessarily required to properly achieve a full recharge.
- Lithium batteries may temporarily disconnect their voltage as they reach a full charge, before the charger is complete. This may cause the charger to repeat its charge initiation sequence when this occurs (various lights and noises may occur during this sequence). This is acceptable and will not harm the battery. Simply unplug or disconnect the charger, if this occurs, and the battery voltage will return.
- Check to see if a full charge was completed in one of the following ways:
 - Battery LED indicators: Spot check the battery LED’s with a quick press and release of the battery Power Button. See the table in Section 10 to determine the SOC.
 - RELiON Battery Display Indicator (BDI): Spot check the accessory gauge to see if battery SOC percentage reached 100%.

15.6. Charge Parameters

LiFePO4 batteries can be charged with either a 1-stage profile (constant current (CC) aka Bulk Stage) or a 2-stage profile (constant current, constant voltage (CC-CV) profile aka Bulk and Absorption Stages). The 1-stage profile will charge the battery ~97% and the 2-stage profile will charge the battery 100%. The 1-stage profile is sufficient, since LiFePO4 batteries do not need to be fully charged; this will not reduce life as it does with lead-acid batteries.

15.6.1. CC Charge Profile - 1 Stage

1-STEP CHARGE DESCRIPTION	STEP	DESCRIPTION	CHARGE PARAMETERS		
Step 1 - Charge at a constant current until the battery reaches termination voltage. Once the termination voltage is reached, stop the charge.	1	Maximum Charge Current per battery	50A for one, <60A for two, <100A for three, and <150A for four		
		SYSTEM VOLTAGE	48V	24V	12V
	Stop	Termination Voltage	55.2V*	27.6V*	13.8V*

15.6.2. CC-CV Charge Profile - 2 Stage

2-STEP CHARGE DESCRIPTION	STEPS	DESCRIPTION	CHARGE PARAMETERS		
Step 1 - Charge at a constant current until the battery reaches absorption voltage.	1	Maximum Charge Current per battery	50A for one, <60A for two, <100A for three, and <150A for four		
		SYSTEM VOLTAGE	48V	24V	12V
Step 2 - Hold absorption voltage until charge current reduces to the termination current.	2	Absorption Voltage	55.2V*	27.6V*	13.8V*
	Stop	Termination Current	1A (per battery) for 15 seconds		

*Ensure that the charging system wiring accounts for voltage drops.

16. BATTERY INDICATOR:

If you are using a voltage-based fuel gauge that is designed for lead-acid batteries it will not accurately provide state of charge (SOC). Please replace your fuel gauge with one that measures current rather than voltage. The BMS in the battery provides the SOC of the battery via CAN. Refer to the RELiON Battery CANbus Specification Document for details.

17. BATTERY STORAGE:

TEMPERATURE	LENGTH
-20°C to 45°C (-4°F to 113°F)	Up to 3 months
-20°C to 35°C (-4°F to 95°F)	3 - 6 months
-20°C to 25°C (-4°F to 77°F)	Up to 12 months

18. ENERGY CONSUMPTION DURING STORAGE:

Important notes about battery self-discharge:

- Vehicles consume battery power when idle (even in tow mode), with the ignition off or with the disconnect switch off.
- The battery BMS uses battery power when idle
- Charge the batteries whenever used to maintain full vehicle range.
- The batteries will turn off after when idle to prevent substantial discharge. See section 12.3 for more details.
- Pressing the Power button for 5 seconds will wake them up

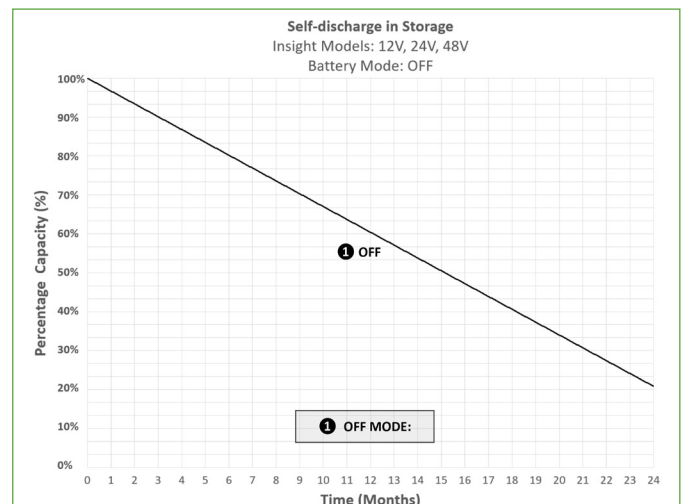
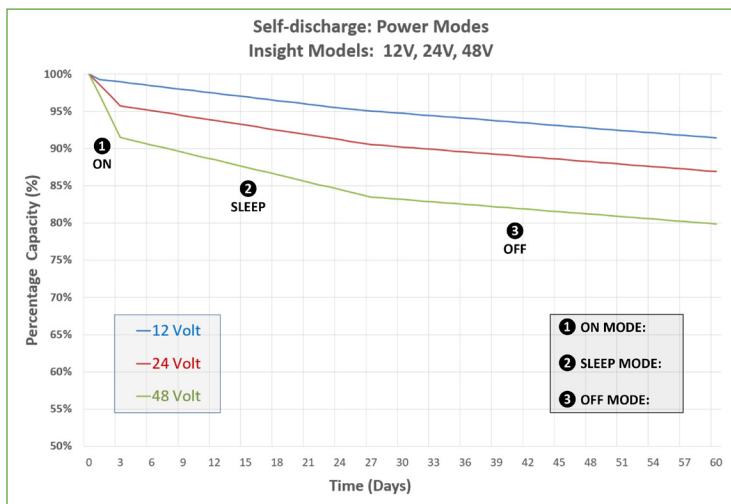

19. RECYCLING:

Terminals must be covered with a protective cap or non-conductive tape prior to battery disposal to lithium recycler. Dispose of LiFePO₄ batteries at an authorized lithium recycling facility.

20. WARRANTY REGISTRATION:

We recommend you protect your investment and register your warranty at reliombattery.com/warranty-registration.

21. PRECAUTIONS:

Lithium Iron Phosphate (LiFePO₄) batteries are an inherently safe chemistry. Please reference RELiON's Lithium Iron Phosphate Safety Document (available on our website at reliombattery.com) for more details. However, as with any electronics, safety measures should always be taken. Please adhere to the instructions within this manual for safe handling and operation.

- Always wear protective gear when handling batteries
- Use a wrench with a rubber coated handle
- Do not place any objects on top of batteries
- Do not place batteries on a metallic surface
- Check that all cables are in good condition
- Make sure all cable connections are properly tightened
- Install and remove batteries using lifting strap brackets
- Do not smoke near batteries
- Do not install batteries in a zero-clearance compartment, overheating may result. Always leave at least 4" of space around all sides and top of battery
- Keep any flammable/combustible material (e.g., paper, cloth, plastic, etc.) that may be ignited by heat, sparks, or flames at a minimum distance of two feet away from the batteries
- Battery compartment and any material within two feet should be noncombustible.
- Keep sparks, flames and metal objects away from batteries
- Have RELiON's LiFePO₄ Safety Data Sheet (SDS) on premises
- Have a Class ABC fire extinguisher on the premises

If you have any technical questions, please contact RELiON Technical Support at 803-547-7288.

