

4

3

2

1

REVISIONS				
ZONE	REV	DESCRIPTION	DATE	APPROVED
--	1	INITIAL RELEASE	2022-FEB-23	MZ

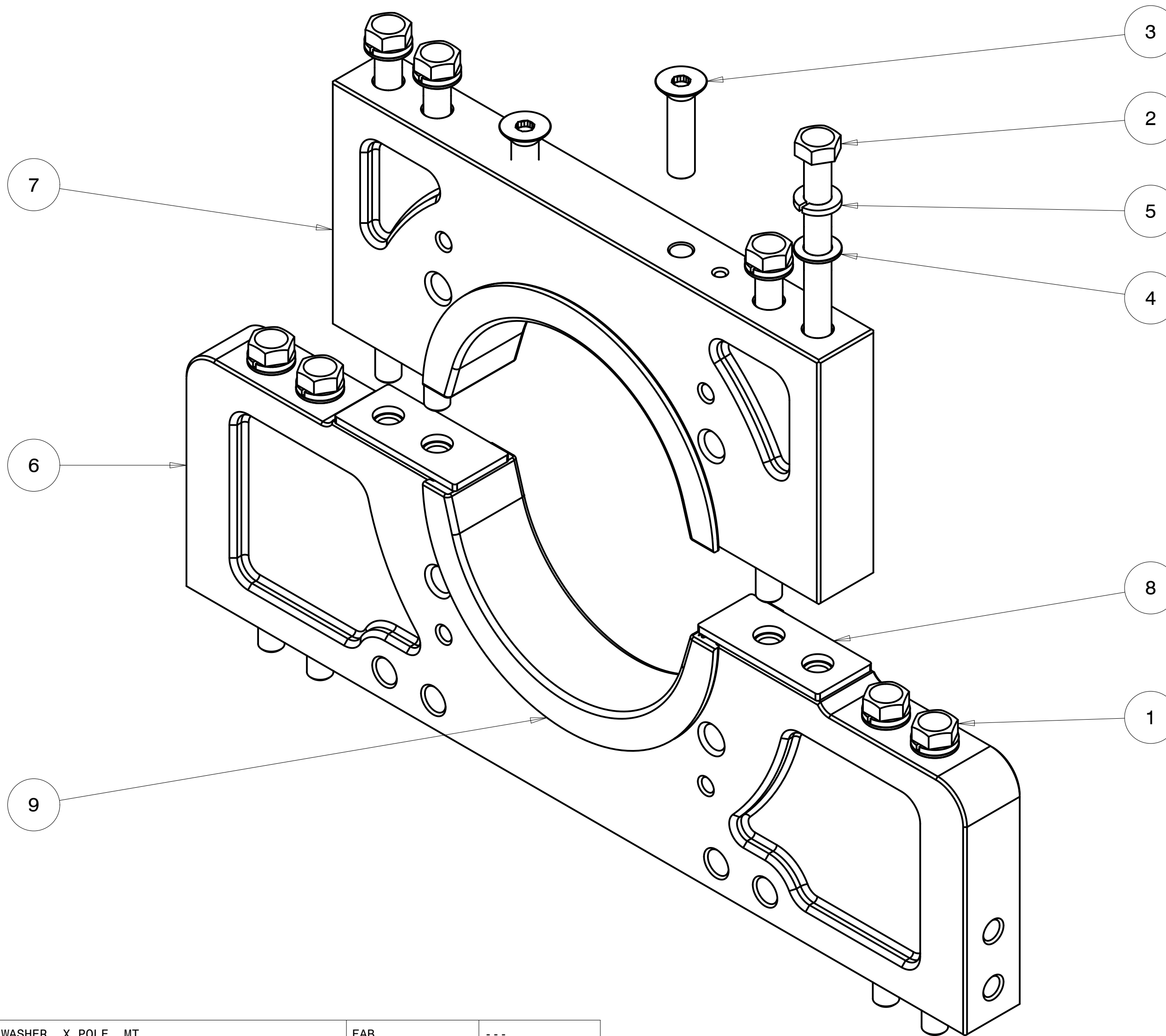

ITEM NO.	QTY REQD.	PART NO.	DRAWING TITLE OR DESCRIPTION	MANUFACTURER	MFG PART NO.
9	2	560-001-1005	COMBINED WASHER, X POLE, MT	FAB	---
8	2	560-001-1004	SHIM, MAIN CLAMP, MT	FAB	---
7	1	560-001-1003-02	TOP BLOCK, MT	FAB	---
6	1	560-001-1002	BOTTOM BLOCK, MT	FAB	---
5	8	90-310-510-870-120-20	WASHER, SPLIT LOCK .510 ID X .87 X .120TK, SST	MCMaster	92146A033
4	8	90-300-515-875-060-20	WASHER, .515 ID X .875 OD X .060 18-8	MCMaster	98017A210
3	2	90-110-500C-2000-20	SCREW, 1/2-13 UNC X 2.0 FHC 18-8	MCMaster	92210A720
2	4	90-104-500C-7500-20	HEX BOLT, 1/2-13 X 7.50 SST 18-8	MCMaster	92198A755
1	4	90-104-500C-6500-20	HEX BOLT, 1/2-13 X 6.50 SST 18-8	MCMaster	92198A754

UNLESS OTHERWISE SPECIFIED DIMENSIONS ARE IN INCHES. TOLERANCES ARE: .X +/- 0.1 .XX +/- 0.01 .XXX +/- 0.001 ANGLES +/- 0.5	CREO REPORTED PARAMETERS	DESIGNER G STAPLES	
	CREO MATERIAL	ENGINEER G STAPLES	2022-MMM-DD
	CREO MASS 21.696	DRAFTER M ZASSO	2022-MMM-DD
	CREO VOLUME 202.288	CHECKED ---	2022-MMM-DD
INTERPRET DIMENSIONS PER ASME Y14.5M 1994 (R2004)	CREO DRAWING FILE NAME: 560-001-9100-02	DO NOT SCALE DRAWING	

UNIVERSAL SONAR MOUNT		
ASSEMBLY, BLOCK, OUTER, MT		
SIZE	CUSTOMER DRAWING/PART NO.	REV
C	---	1
DRAWING/PART NO. 560-001-9100-02		
SCALE	0.625	SHEET 1 OF 2

4

3

2

1

CUSTOMER DRAWING/PART NO. ---
DRAWING/PART NO. 560-001-9100-02
REV 1
SHT 1

D

D

C

B

A

A

4

3

2

1

REVISIONS
SEE SHEET 1

CUSTOMER DRAWING/PART NO.

DRAWING/PART NO.

560-001-9100-02

REV

1

SHT

2

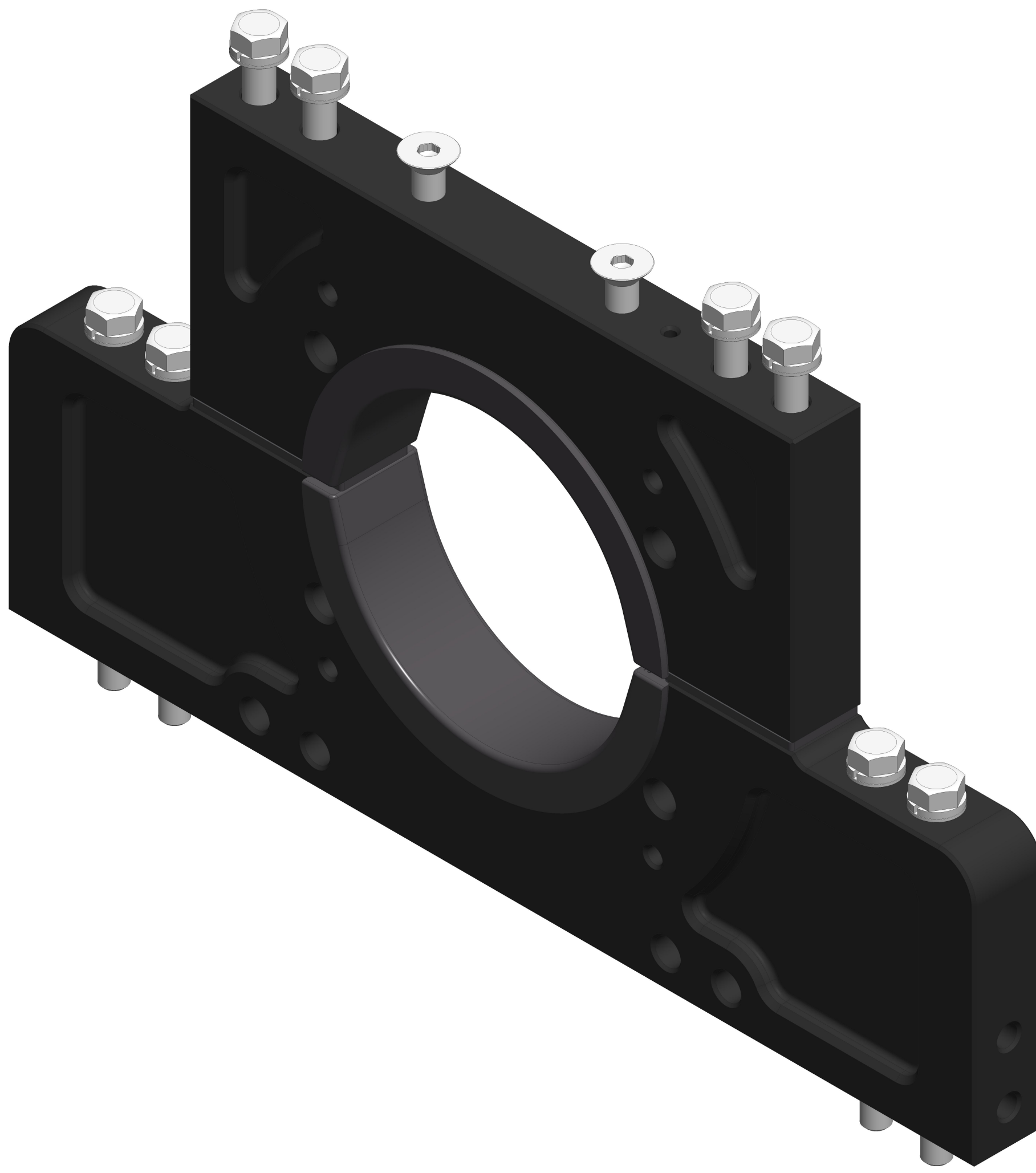

UNIVERSAL SONAR MOUNT		
ASSEMBLY, BLOCK, OUTER, MT		
SIZE	CUSTOMER DRAWING/PART NO.	REV
C	---	1
	DRAWING/PART NO. 560-001-9100-02	
SCALE	0.625	SHEET 2 OF 2

4

3

2

1

A

D

C

B

A

D

C

B

A