

4

3

2

1

REVISIONS				
ZONE	REV	DESCRIPTION	DATE	APPROVED
--	1	INITIAL RELEASE	2022-JUL-19	MZ

D

D

C

B

A

CUSTOMER DRAWING/PART NO.

DRAWING/PART NO.

REV

SHT

A

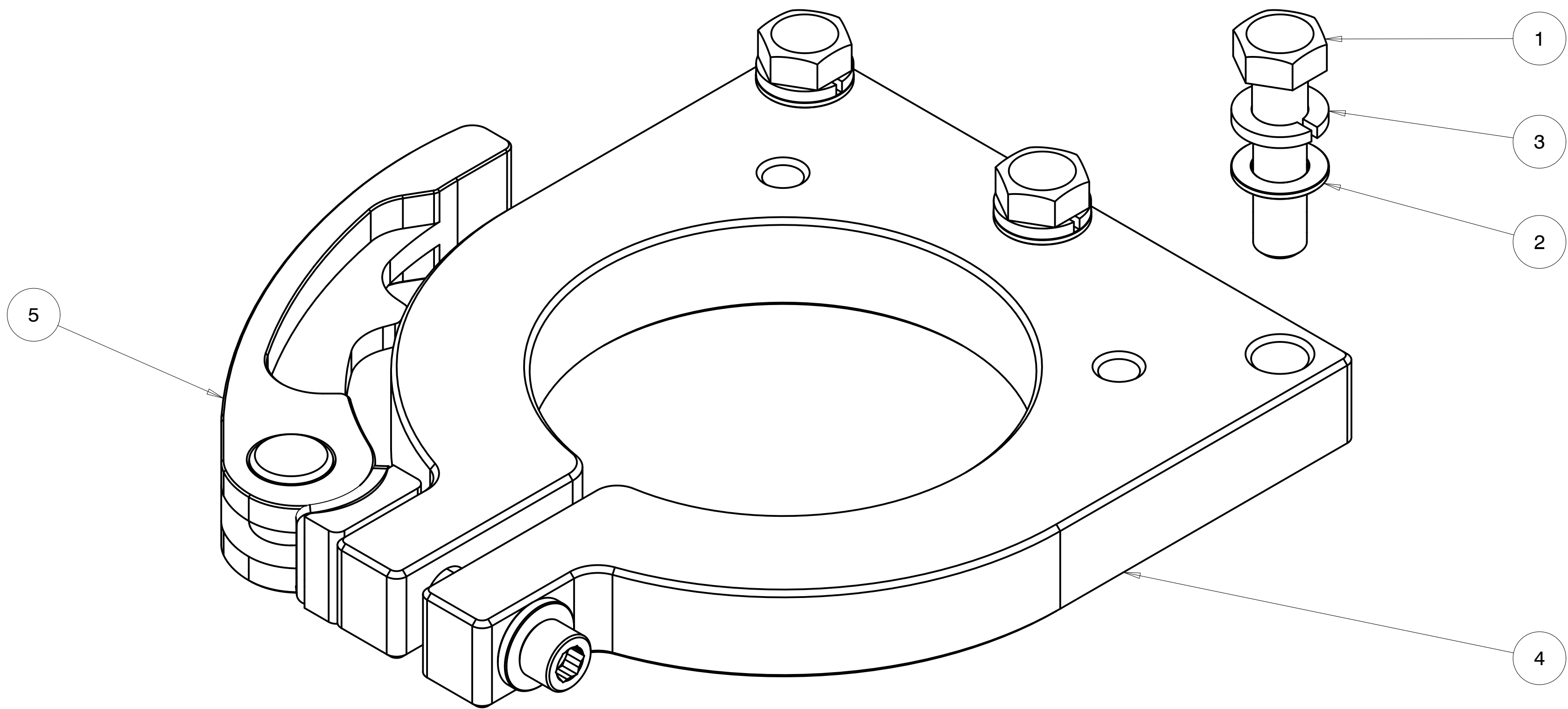

UNIVERSAL SONAR MOUNT		
ASSEMBLY, Z-CLAMP, 1 PIECE, 4.5"		
SIZE	CUSTOMER DRAWING/PART NO.	REV
C	---	1
DRAWING/PART NO.		
540-R45-9432		
SCALE	SHEET 1 OF 2	
1:250		

ITEM NO.	QTY REQD.	PART NO.	DRAWING TITLE OR DESCRIPTION	MANUFACTURER	MFG PART NO.
5	1	501-9440-01-B	OC LEVER, Z CLAMP, SL ,GEN-USM	ASSY	---
4	1	500-1432	Z-CLAMP, 1 PIECE	FAB	---
3	3	90-310-510-870-120-20	WASHER, SPLIT LOCK .510 ID X .87 X .120TK, SST	MCMaster	92146A033
2	3	90-300-515-875-060-20	WASHER, .515 ID X .875 OD X .060 18-8	MCMaster	98017A210
1	3	90-104-500C-2000-20	HEX BOLT, 1/2-13 X 2.000 SST 18-8	MCMaster	92198A720

UNLESS OTHERWISE SPECIFIED DIMENSIONS ARE IN INCHES. TOLERANCES ARE: .X +/- 0.1 .XX +/- 0.01 .XXX +/- 0.001 ANGLES +/- 0.5 INTERPRET DIMENSIONS PER ASME Y14.5M 1994 (R2004)	CREO REPORTED PARAMETERS		DESIGNER	
	CREO MATERIAL		M ZASSO	
	CREO MASS	3.882	ENGINEER	M ZASSO 2022-JUL-18
	CREO VOLUME	34.819	DRAFTER	M ZASSO 2022-JUL-18
	CREO DRAWING FILE NAME:	540-R45-9432	CHECKED	--- 2022-MMM-DD
		DO NOT SCALE DRAWING		

4

3

2

1

4

3

2

1

REVISIONS
SEE SHEET 1

CUSTOMER DRAWING/PART NO.

DRAWING/PART NO.

540-R45-9432

REV

1

SHT

2

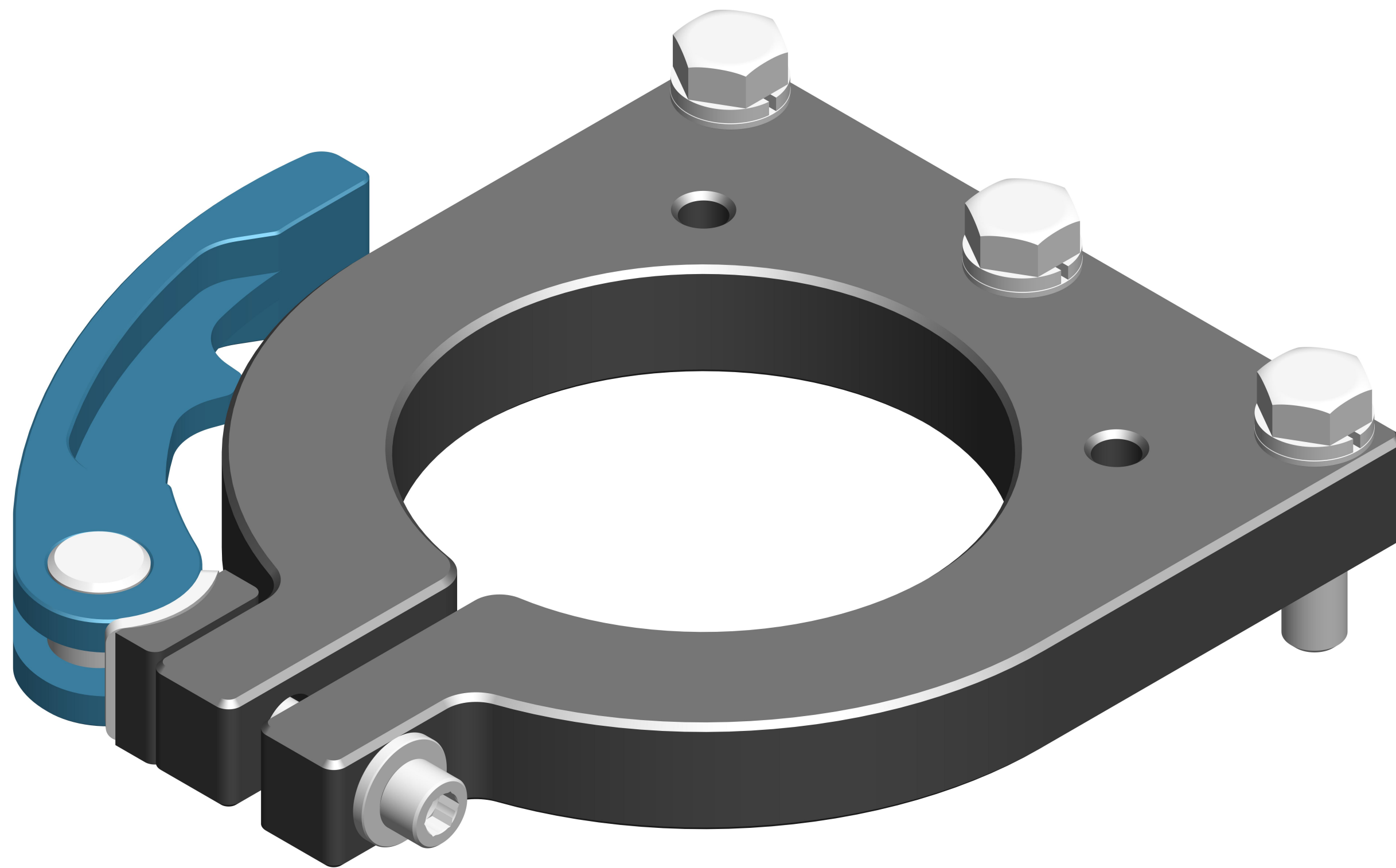

UNIVERSAL SONAR MOUNT		
ASSEMBLY, Z-CLAMP, 1 PIECE, 4.5"		
SIZE	CUSTOMER DRAWING/PART NO.	REV
C	---	1
	DRAWING/PART NO. 540-R45-9432	
SCALE	1.250	SHEET 2 OF 2

4

3

2

1

A

D

C

B

A

D

C

B

A