

REVISIONS				
ZONE	REV	DESCRIPTION	DATE	APPROVED
--	1	INITIAL RELEASE	2022-JUL-19	MZ

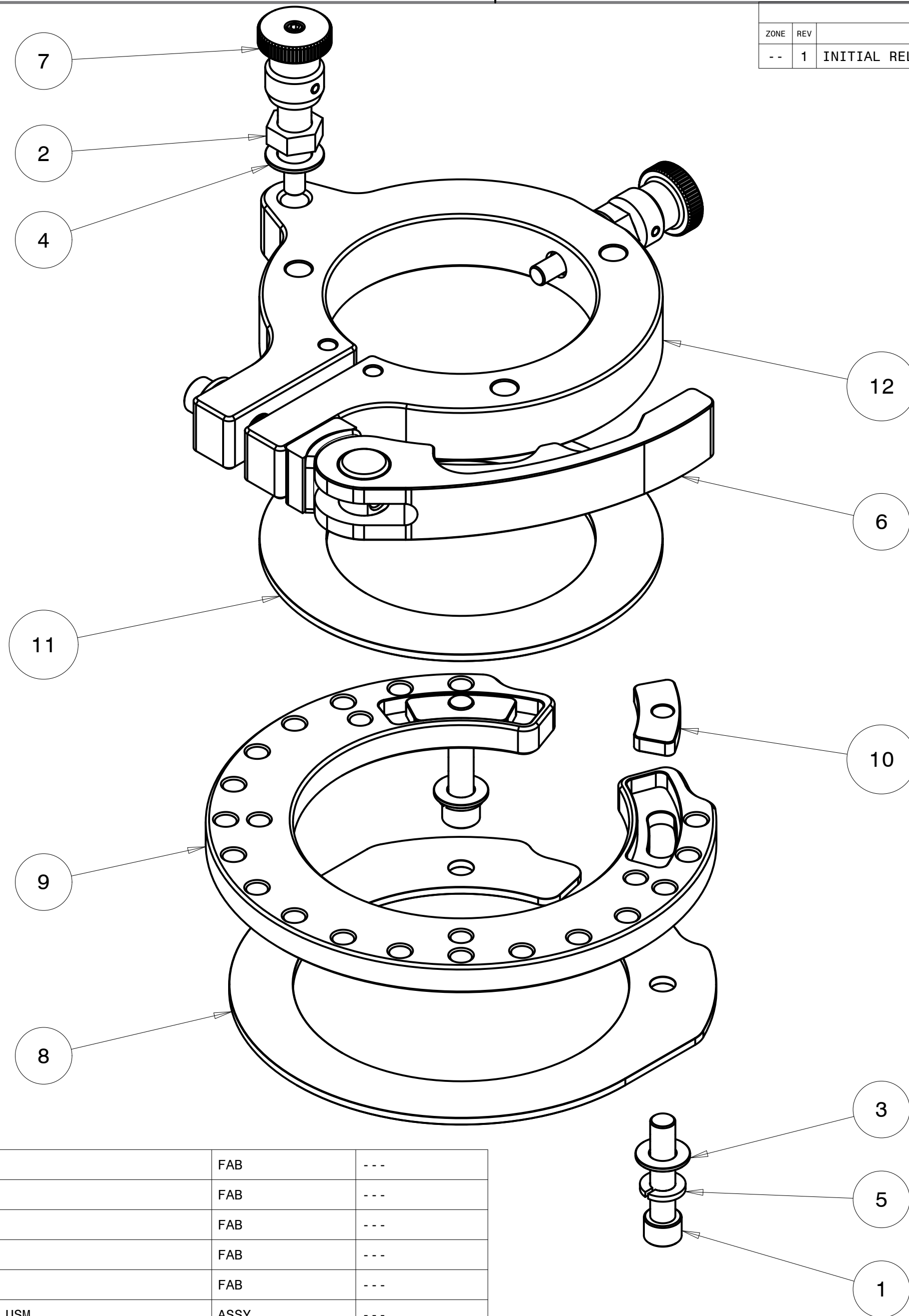

ITEM NO.	QTY REQD.	PART NO.	DRAWING TITLE OR DESCRIPTION	MANUFACTURER	MFG PART NO.
12	1	503-1461	LOWER INDEX CLAMP, EXP, USM	FAB	---
11	1	503-1414-01	SHIM, INDEX CLAMP, 4.0"	FAB	---
10	2	503-1412	PIN PLATE, T NUT	FAB	---
9	1	503-1411	PIN PLATE, EXPD, USM	FAB	---
8	1	503-1410	SHIM, PIN PLATE	FAB	---
7	2	501-9901-B	ASSY, LOCKING PULL PIN, BLUE, USM	ASSY	---
6	1	501-9440-01-B	OC LEVER, Z CLAMP, SL ,GEN-USM	ASSY	---
5	2	90-310-380-680-090-20	WASHER, SPLIT LOCK .380 ID X 68 OD X .090TK, 18-8 SST	MCMMASTER	92146A031
4	2	90-300-515-875-060-20	WASHER, .515 ID X .875 OD X .060 18-8	MCMMASTER	98017A210
3	2	90-300-406-813-060-20	WASHER, .406" ID X .813" OD X .060" TH, 18-8 SST	MCMMASTER	96659A108
2	2	90-201-500C-20	JAM NUT, 1/2-13 SST 18-8	MCMMASTER	91847A520
1	2	90-100-375C-1750-20	SCREW, 3/8-16 X 1.75 SHC 18-8	MCMMASTER	92196A630

UNLESS OTHERWISE SPECIFIED DIMENSIONS ARE IN INCHES.		CREO REPORTED PARAMETERS		DESIGNER	
TOLERANCES ARE:		CREO MATERIAL		M ZASSO	
.X +/-	0.1	CREO MASS		ENGINEER	M ZASSO
.XX +/-	0.01	4.028		DRAFTER	M ZASSO
.XXX +/-	0.001	CREO VOLUME		CHECKED	---
ANGLES +/-	0.5	38.472		DATE	2022-JUL-19
INTERPRET DIMENSIONS PER ASME Y14.5M 1994 (R2004)		CREO DRAWING FILE NAME:		DO NOT SCALE DRAWING	
		540-R40-9461		2022-MMM-DD	

UNIVERSAL SONAR MOUNT		
ASSEMBLY, PAN INDEX, 4.0"		
SIZE	CUSTOMER DRAWING/PART NO.	REV
C	---	1
DRAWING/PART NO.		
540-R40-9461		
SCALE	0.700	SHEET 1 OF 2

4

3

2

1

REVISIONS  
SEE SHEET 1

CUSTOMER DRAWING/PART NO.

DRAWING/PART NO.

540-R40-9461

REV

SHT

1  
2

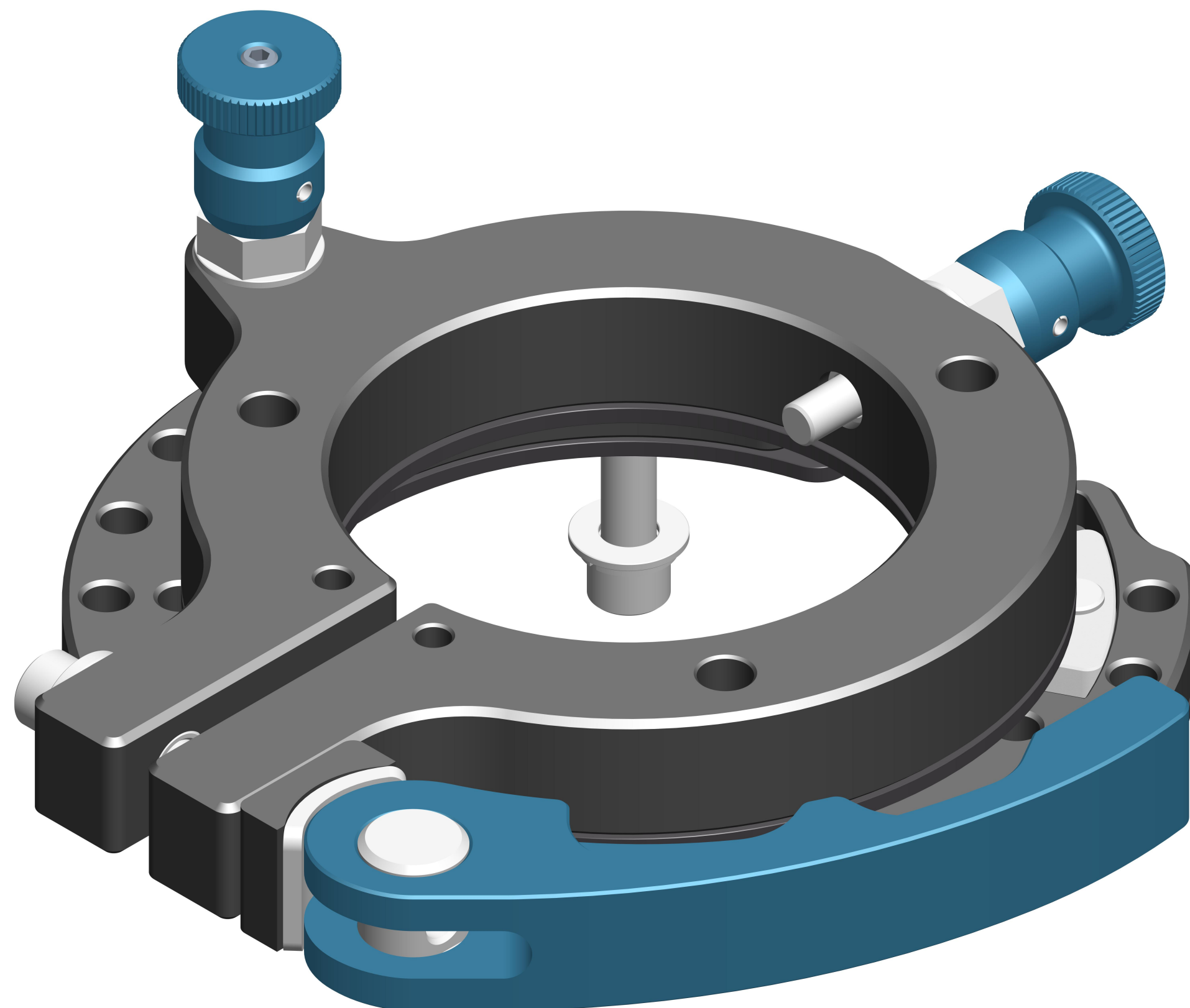

UNIVERSAL SONAR MOUNT		
ASSEMBLY, PAN INDEX, 4.0"		
SIZE	CUSTOMER DRAWING/PART NO.	REV
<b>C</b>	---	1
	DRAWING/PART NO.	
	540-R40-9461	
SCALE	1.250	SHEET 2 OF 2

4

3

2

1

A

D

C

B

A