

REVISIONS				
ZONE	REV	DESCRIPTION	DATE	APPROVED
--	1	INITIAL RELEASE	2022-FEB-28	MZ

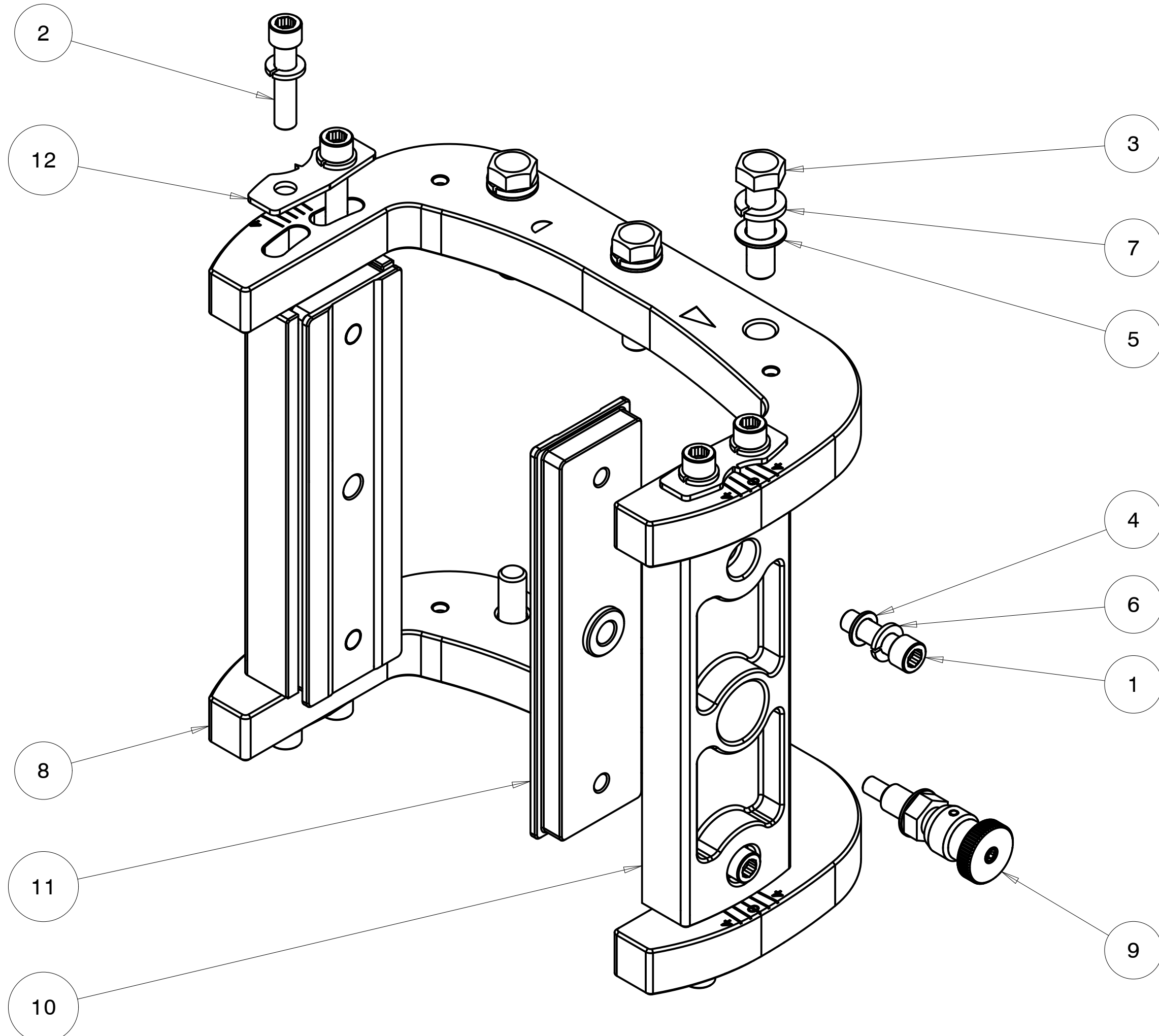

ITEM NO.	QTY REQD.	PART NO.	DRAWING TITLE OR DESCRIPTION	MANUFACTURER	MFG PART NO.
12	4	520-100-1060	POINTER, YAW ADJUSTMENT	FAB	---
11	2	520-100-1059	8" TRACK BLOCK, FOIL MOUNT	FAB	---
10	2	520-100-1058	8" CLAMPING BLOCK, FOIL MOUNT	FAB	---
9	1	501-9901	ASSEMBLY, LOCKING PULL PIN, USM	ASSY	---
8	2	500-000-1025	4.5" C-CLAMP	FAB	---
7	6	90-310-510-870-120-20	WASHER, SPLIT LOCK .510 ID X .87 X .120TK, SST	MCMaster	92146A033
6	12	90-310-380-680-090-20	WASHER, SPLIT LOCK .380 ID X .68 OD X .090TK, 18-8 SST	MCMaster	92146A031
5	6	90-300-515-875-060-20	WASHER, .515 ID X .875 OD X .060 18-8	MCMaster	98017A210
4	4	90-300-390-625-06-20	WASHER, .390 X .63 X .060 18-8 SST	MCMaster	98017A200
3	6	90-104-500C-2000-20	HEX BOLT, 1/2-13 X 2.000 SST 18-8	MCMaster	92198A720
2	9	90-100-375C-1750-20	SCREW, 3/8-16 X 1.75 SHC 18-8	MCMaster	92196A630
1	4	90-100-375C-1250-20	SCREW, 3/8-16 X 1.250 SHC 18-8	MCMaster	92196A626

UNLESS OTHERWISE SPECIFIED DIMENSIONS ARE IN INCHES. TOLERANCES ARE: .X +/- 0.1 .XX +/- 0.01 .XXX +/- 0.001 ANGLES +/- 0.5	CREO REPORTED PARAMETERS	DESIGNER G STAPLES	
	CREO MATERIAL	ENGINEER G STAPLES	2022-MMM-DD
	CREO MASS 11.863	DRAFTER M ZASSO	2022-MMM-DD
	CREO VOLUME 105.641	CHECKED ---	2022-MMM-DD
INTERPRET DIMENSIONS PER ASME Y14.5M 1994 (R2004)	CREO DRAWING FILE NAME: 540-F45-9026-I	DO NOT SCALE DRAWING	

UNIVERSAL SONAR MOUNT		
ASSEMBLY, 4.5" FOIL CLAMPS, INDEXED, HIGHTOWER		
SIZE	CUSTOMER DRAWING/PART NO.	REV
C	---	1
DRAWING/PART NO. 540-F45-9026-I		
SCALE	0.600	SHEET 1 OF 2

4

3

2

1

REVISIONS
SEE SHEET 1

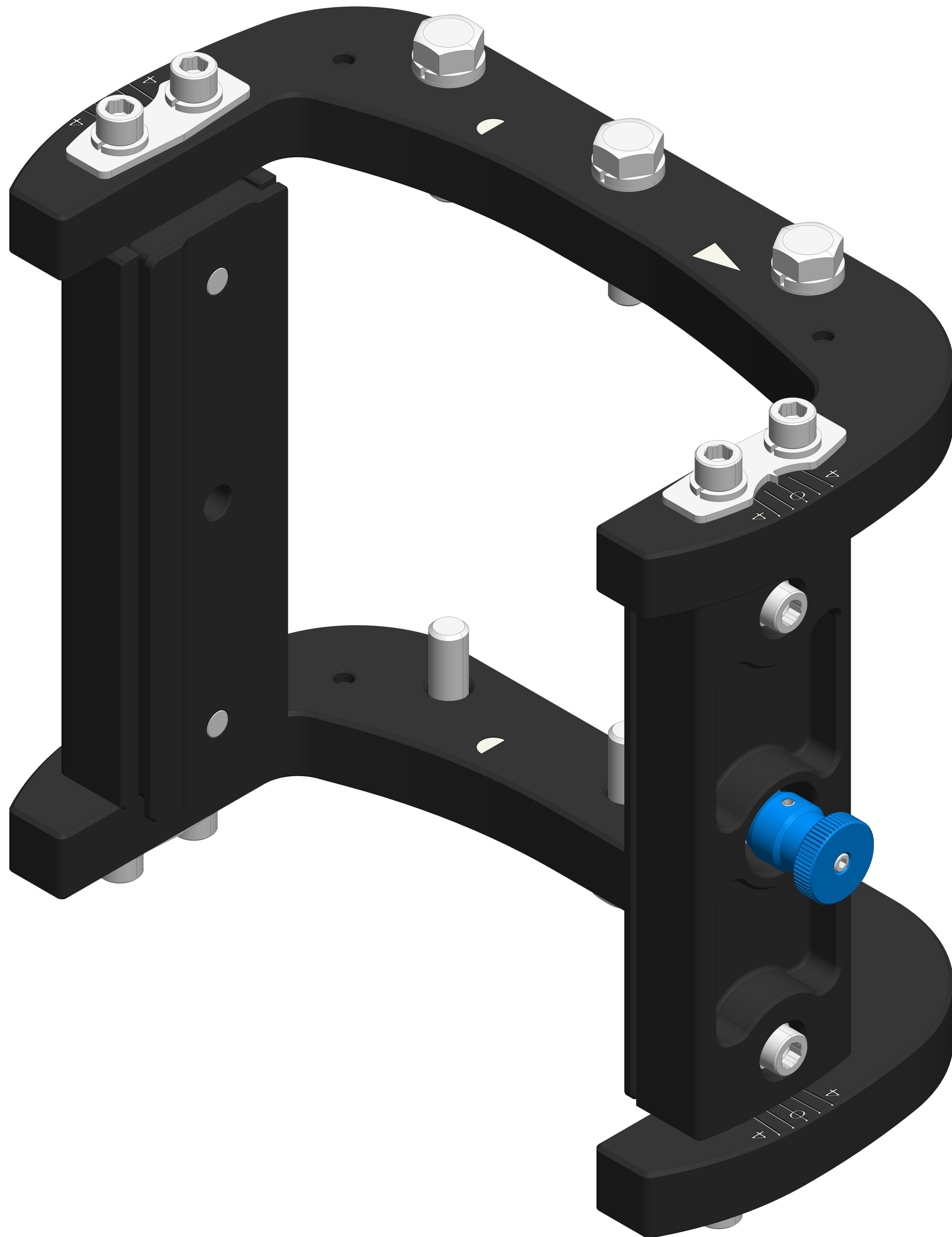

UNIVERSAL SONAR MOUNT		
ASSEMBLY, 4.5" FOIL CLAMPS, INDEXED, HIGHTOWER		
SIZE	CUSTOMER DRAWING/PART NO.	REV
C	---	1
	DRAWING/PART NO.	
	540-F45-9026-I	
SCALE	1.000	SHEET 2 OF 2

CUSTOMER DRAWING/PART NO.

DRAWING/PART NO.

540-F45-9026-I

REV

1

SHT

2

A

4

3

2

1

D

D

C

B

A