

4

3

2

1

REVISIONS				
ZONE	REV	DESCRIPTION	DATE	APPROVED
--	1	INITIAL RELEASE	02022-JAN-19	MZ

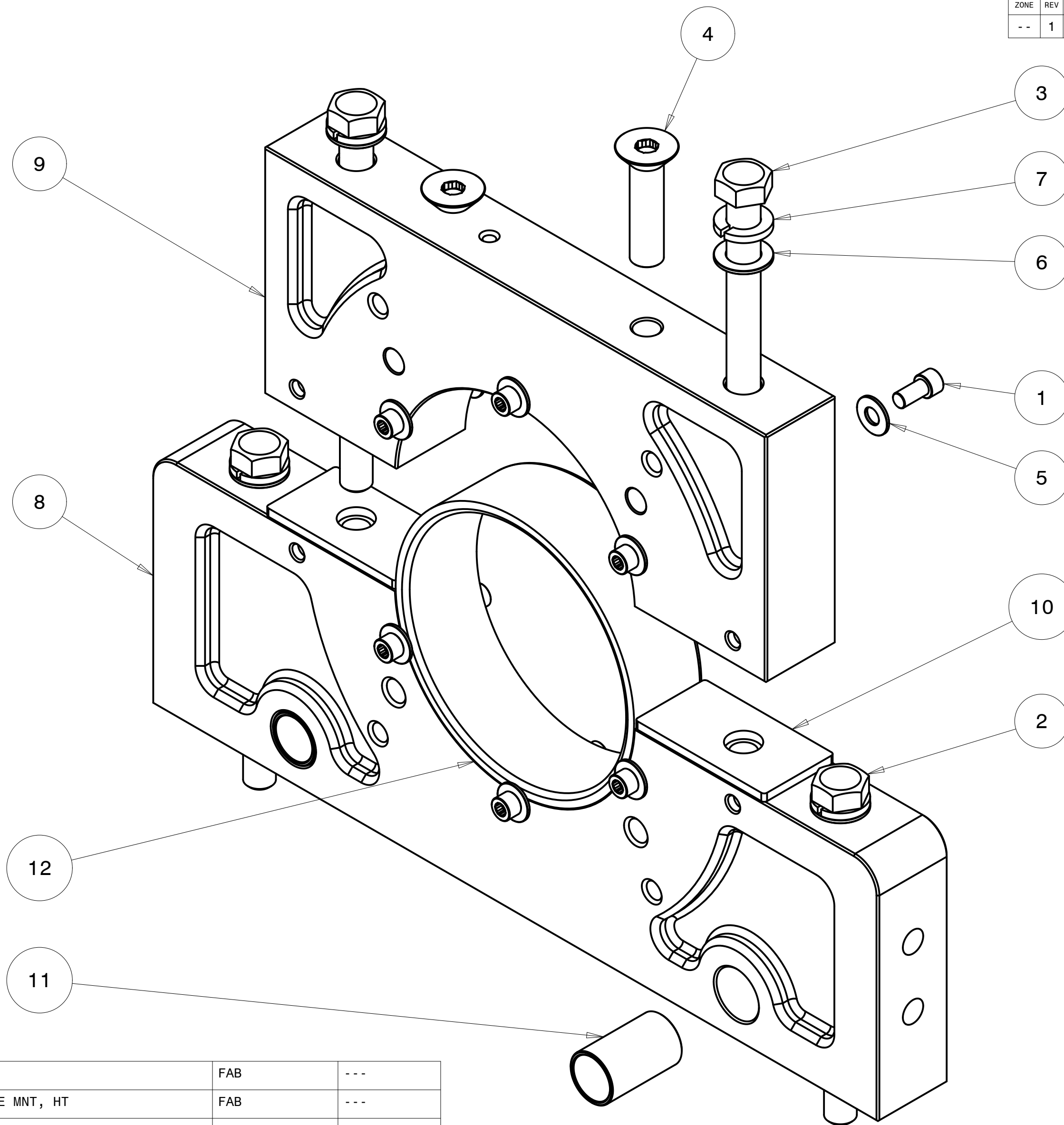

ITEM NO.	QTY REQD.	PART OR IDENTIFYING NO.	DRAWING TITLE OR DESCRIPTION	MANUFACTURER	MFG PART NO.
12	1	500-1003-IM	BUSHING, MAIN SHAFT, HT	FAB	---
11	2	500-001-1008	PIVOT BUSHING, GEAR DRIVE MNT, HT	FAB	---
10	2	500-001-1004	SHIM, MAIN CLAMP, HT	FAB	---
9	1	500-001-1003-02	TOP BLOCK, HT	FAB	---
8	1	500-001-1002	BOTTOM BLOCK, HT	FAB	---
7	4	90-310-510-870-120-20	WASHER, SPLIT LOCK .510 ID X .87 X .120TK, SST	MCMASTER	92146A033
6	4	90-300-515-875-060-20	WASHER, .515 ID X .875 OD X .060 18-8	MCMASTER	98017A210
5	12	90-300-281-625-050-20	WASHER, .281 X .625 OD X .050 THICK, SST	MCMASTER	92141A029
4	2	90-110-500C-2000-20	SCREW, 1/2-13 UNC X 2.0 FHC 18-8	MCMASTER	92210A720
3	2	90-104-500C-6500-20	HEX BOLT, 1/2-13 X 6.50 SST 18-8	MCMASTER	92198A754
2	2	90-104-500C-5750-20	HEX BOLT, 1/2-13 X 5.75 SST 18-8	MCMASTER	92314A413
1	12	90-100-250C-500-20	SCREW, 1/4-20 X .50 SHC 18-8	MCMASTER	92196A537

UNLESS OTHERWISE SPECIFIED DIMENSIONS ARE IN INCHES. TOLERANCES ARE:	CREO REPORTED PARAMETERS	DESIGNER	
		G STAPLES	
.X +/- 0.1	CREO MATERIAL	ENGINEER	G STAPLES 02021-JAN-28
.XX +/- 0.01	CREO MASS	DRAFTER	G STAPLES 02021-JAN-28
.XXX +/- 0.001	CREO VOLUME	CHECKED	---
ANGLES +/- 0.5	CREO DRAWING FILE NAME:	DO NOT SCALE DRAWING	
INTERPRET DIMENSIONS PER ASME Y14.5M 1994 (R2004)	540-001-9100-02		

UNIVERSAL SONAR MOUNT		
ASSEMBLY, BLOCK, OUTER, HT		
SIZE	CUSTOMER DRAWING/PART NO.	REV
C	---	1
DRAWING/PART NO.		
540-001-9100-02		
SCALE	0.750	SHEET 1 OF 2

4

3

2

1

CUSTOMER DRAWING/PART NO. 540-001-9100-02

REV 1 SHT 1

A

4

3

2

1

REVISIONS
SEE SHEET 1

CUSTOMER DRAWING/PART NO.

DRAWING/PART NO.

540-001-9100-02

REV

1

SHT

2

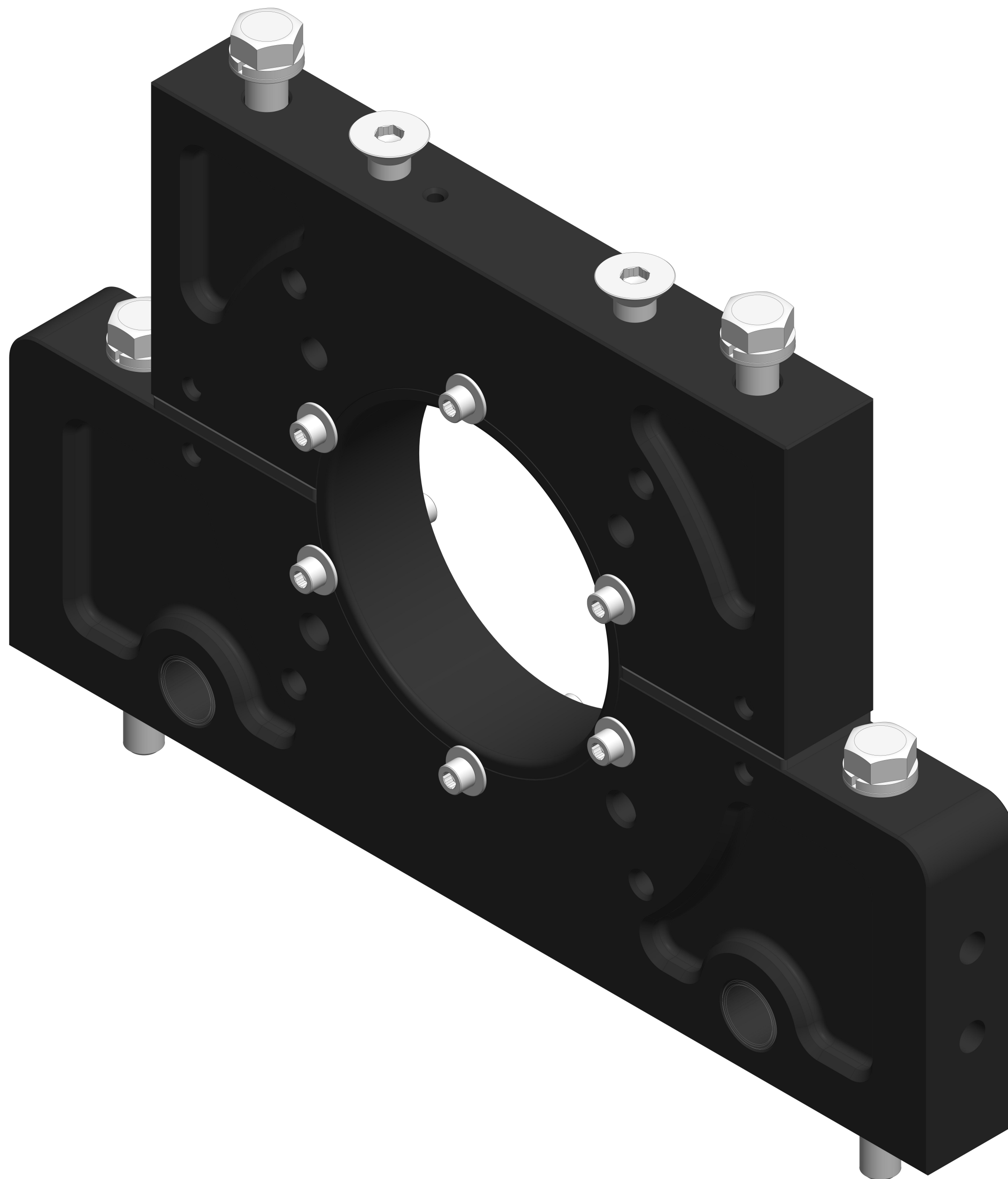

UNIVERSAL SONAR MOUNT		
ASSEMBLY, BLOCK, OUTER, HT		
SIZE	CUSTOMER DRAWING/PART NO.	REV
C	---	1
	DRAWING/PART NO. 540-001-9100-02	
SCALE	1.000	SHEET 2 OF 2

4

3

2

1

A

D

D

C

B

A