

4

3

2

1

REVISIONS				
ZONE	REV	DESCRIPTION	DATE	APPROVED
--	1	INITIAL RELEASE	2022-FEB-02	MZ

D

D

C

B

A

CUSTOMER DRAWING/PART NO.

DRAWING/PART NO.

540-001-9052

REV

1

SHT

1

ADD BLUE LOCTITE

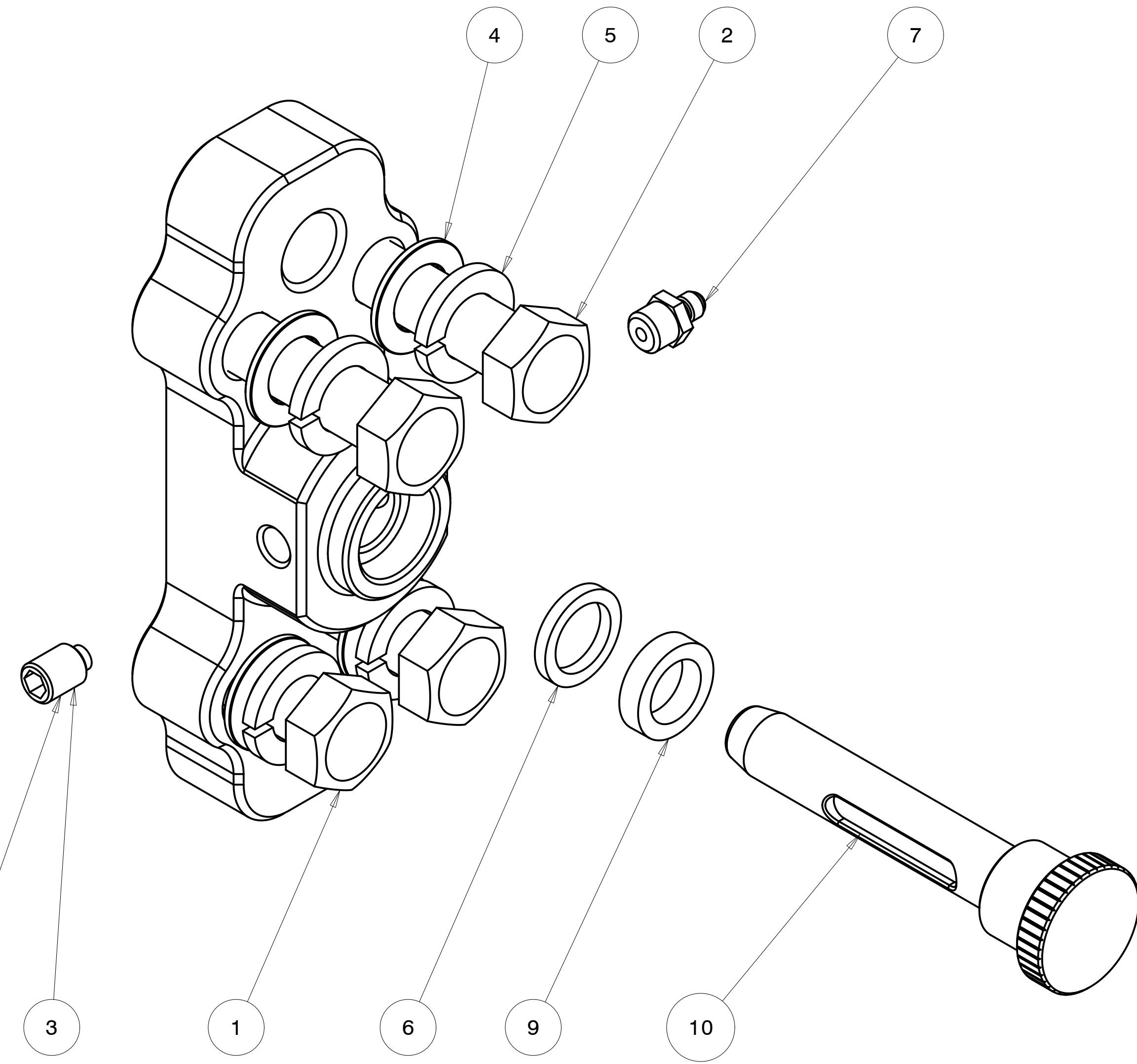

ITEM NO.	QTY REQD.	PART OR IDENTIFYING NO.	DRAWING TITLE OR DESCRIPTION	MANUFACTURER	MFG PART NO.
10	1	505-001-1109	LOCK PIN, GEAR DRIVE, HT	FAB	---
9	1	505-001-1104	RETAINER, SEAL .500 ID X .750 OD X .185	FAB	---
8	1	500-001-1052	PIN BLOCK, SUPPORT BRACKET, HT	FAB	---
7	1	94-350-313F-344-01-23	GREASE FITTING, 5/16-24-UNF STRAIGHT 303 SST	MCMaster	1293K44
6	1	94-335-549-755-103-80	SEAL, GREASE .549 ID X .755 OD X .103 W BUNA N	MCMaster	4061T159
5	4	90-310-510-870-120-20	WASHER, SPLIT LOCK .510 ID X .87 X .120TK, SST	MCMaster	92146A033
4	4	90-300-515-875-060-20	WASHER, .515 ID X .875 OD X .060 18-8	MCMaster	98017A210
3	1	90-153-313C-375-188-094-20	SET SCREW, PILOT POINT 5/16-18 UNC X .375, SST	MCMaster	90291A576
2	2	90-104-500C-2000-20	HEX BOLT, 1/2-13 X 2.000 SST 18-8	MCMaster	92198A720
1	2	90-104-500C-1250-20	HEX BOLT, 1/2-13 X 1.250 SST 18-8	MCMaster	92240A714

UNLESS OTHERWISE SPECIFIED DIMENSIONS ARE IN INCHES.	CREO REPORTED PARAMETERS		DESIGNER	
	TOLERANCES ARE:	CREO MATERIAL	G STAPLES	
.X +/- 0.1	1.832	ENGINEER	G STAPLES	02021-JAN-28
.XX +/- 0.01		DRAFTER	G STAPLES	02021-JAN-28
.XXX +/- 0.001	CREO VOLUME	CHECKED	---	02021-MMM-DD
ANGLES +/- 0.5	11.227			
INTERPRET DIMENSIONS PER ASME Y14.5M 1994 (R2004)	CREO DRAWING FILE NAME:	DO NOT SCALE DRAWING		
	540-001-9052			

UNIVERSAL SONAR MOUNT		
ASSEMBLY, CATCHER		
SIZE	CUSTOMER DRAWING/PART NO.	REV
C	---	1
DRAWING/PART NO.		
540-001-9052		
SCALE	1.500	SHEET 1 OF 2

4

3

2

1

A

4

3

2

1

REVISIONS
SEE SHEET 1

D

D

C

B

A

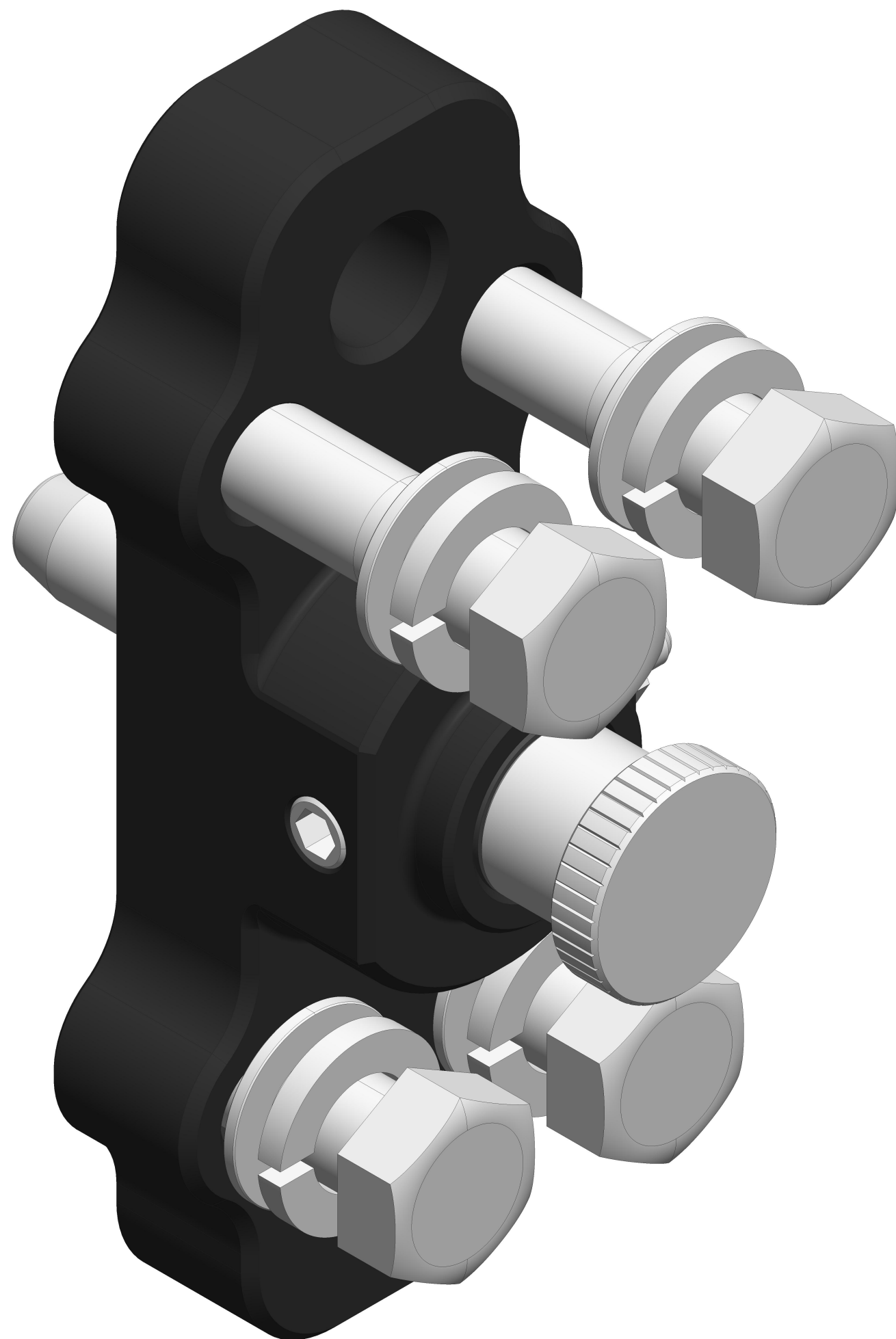

CUSTOMER DRAWING/PART NO.

DRAWING/PART NO.

540-001-9052

REV

1

SHT

2

UNIVERSAL SONAR MOUNT

ASSEMBLY, CATCHER

SIZE	CUSTOMER DRAWING/PART NO.	REV
C	---	1
	DRAWING/PART NO. 540-001-9052	

SCALE 1.500 SHEET 2 OF 2

4

3

2

1

A