

REVISIONS				
ZONE	REV	DESCRIPTION	DATE	APPROVED
--	1	INITIAL RELEASE	02022-JAN-19	MZ

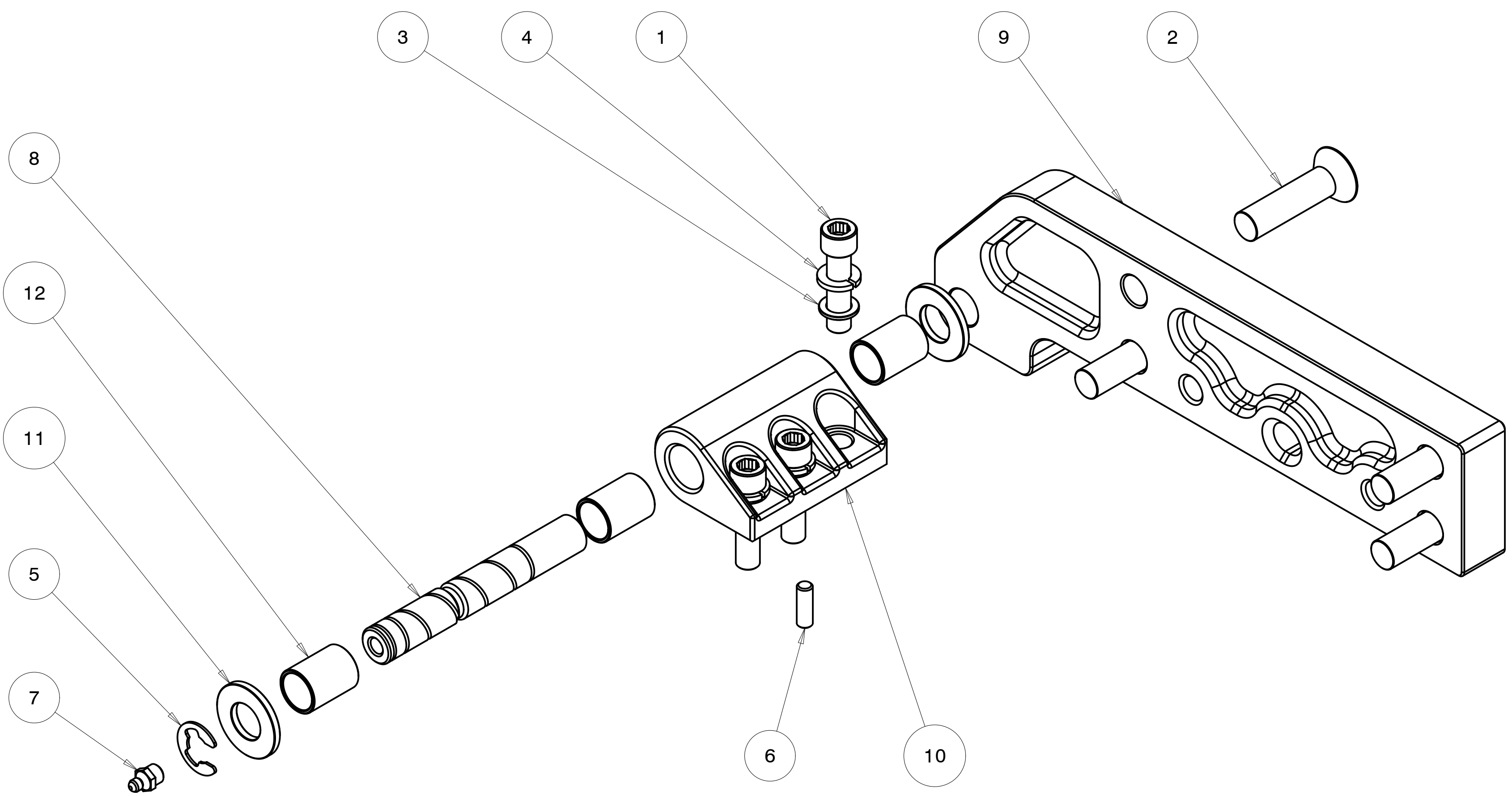

12	3	500-1042	BUSHING, HINGE KNUCKLE	FAB	---
11	2	500-1038	HINGE WASHER, 1.275 OD X .630 ID X .125 TH	FAB	---
10	1	500-1036-01	HINGE KNUCKLE	FAB	---
9	1	500-001-1025-01	HINGE STRAP, LEFT, HT	FAB	---
8	1	500-001-1024	HINGE SHAFT, HT	FAB	---
7	1	94-350-313F-344-01-23	GREASE FITTING, 5/16-24-UNF STRAIGHT 303 SST	MCMaster	1293K44
6	2	90-400-250-750-20	DOWEL PIN, .250 DIA X .750 18-8	MCMaster	90145A540
5	1	90-355-485-042-20	E-CLIP, .625 SHAFT, .485 GROOVE, .042 W, SST	MCMaster	98408A140
4	3	90-310-380-680-090-20	WASHER, SPLIT LOCK .380 ID X .68 OD X .090TK, 18-8 SST	MCMaster	92146A031
3	3	90-300-390-625-06-20	WASHER, .390 X .63 X .060 18-8 SST	MCMaster	98017A200
2	4	90-110-500C-2000-20	SCREW, 1/2-13 UNC X 2.0 FHC 18-8	MCMaster	92210A720
1	3	90-100-375C-1500-20	SCREW, 3/8-16 X 1.500 SHC 18-8 SST	MCMaster	92196A628
ITEM NO.	QTY REQD.	PART OR IDENTIFYING NO.	DRAWING TITLE OR DESCRIPTION	MANUFACTURER	MFG PART NO.

UNLESS OTHERWISE SPECIFIED DIMENSIONS ARE IN INCHES. TOLERANCES ARE: .X +/- 0.1 .XX +/- 0.01 .XXX +/- 0.001 ANGLES +/- 0.5 INTERPRET DIMENSIONS PER ASME Y14.5M 1994 (R2004)	CREO REPORTED PARAMETERS		DESIGNER G STAPLES	
	CREO MATERIAL	ENGINEER G STAPLES	02021-JAN-28	
	CREO MASS 3.639	DRAFTER G STAPLES	02021-JAN-28	
	CREO VOLUME 29.615	CHECKED ---	02021-MMM-DD	
CREO DRAWING FILE NAME: 540-001-9025-01		DO NOT SCALE DRAWING		

UNIVERSAL SONAR MOUNT		
ASSEMBLY, HINGE, LEFT, HT		
SIZE	CUSTOMER DRAWING/PART NO.	REV
C	---	1
DRAWING/PART NO. 540-001-9025-01		
SCALE	0.750	SHEET 1 OF 2

CUSTOMER DRAWING/PART NO. ---  
 DRAWING/PART NO. 540-001-9025-01  
 REV 1  
 SH1 1

