

4

3

2

1

REVISIONS				
ZONE	REV	DESCRIPTION	DATE	APPROVED
--	1	INITIAL RELEASE	2022-FEB-28	MZ

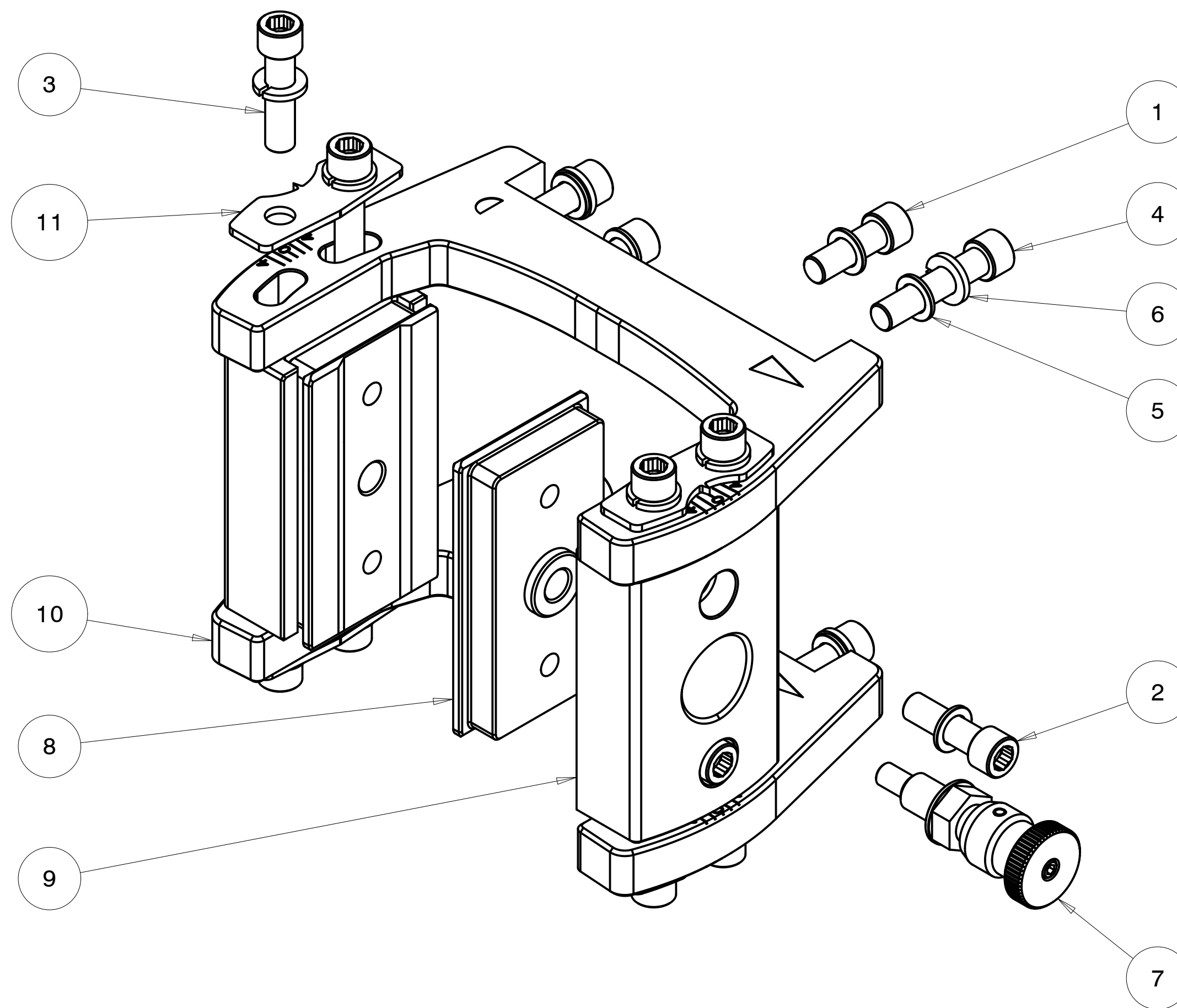

ITEM NO.	QTY REQD.	PART NO.	DRAWING TITLE OR DESCRIPTION	MANUFACTURER	MFG PART NO.
11	4	520-100-1060	POINTER, YAW ADJUSTMENT	FAB	---
10	2	520-100-1056	3.5" C-CLAMP, COMPACT	FAB	---
9	2	520-100-1054	4" CLAMPING BLOCK, FOIL MOUNT	FAB	---
8	2	520-100-1053	4" TRACK BLOCK, FOIL MOUNT	FAB	---
7	1	501-9901	ASSEMBLY, LOCKING PULL PIN, USM	ASSY	---
6	12	90-310-380-680-090-20	WASHER, SPLIT LOCK .380 ID X .625 OD X .090TK,18-8 SST	MCMASTER	92146A031
5	12	90-300-390-625-060-20	WASHER, .390 X .625 OD X .060 THICK, SST	MCMASTER	98017A200
4	4	90-100-375C-1750-20	SCREW, 3/8-16 X 1.75 SHC 18-8	MCMASTER	92196A630
3	8	90-100-375C-1500-20	SCREW, 3/8-16 X 1.500 SHC 18-8 SST	MCMASTER	92196A628
2	4	90-100-375C-1250-20	SCREW, 3/8-16 X 1.250 SHC 18-8	MCMASTER	92196A626
1	4	90-100-375C-1125-20	SCREW, 3/8-16 X 1.125 SHC 18-8	MCMASTER	92196A625

UNLESS OTHERWISE SPECIFIED DIMENSIONS ARE IN INCHES. TOLERANCES ARE: .X +/- 0.1 .XX +/- 0.01 .XXX +/- 0.001 ANGLES +/- 0.5 INTERPRET DIMENSIONS PER ASME Y14.5M 1994 (R2004)	CREO REPORTED PARAMETERS		DESIGNER G STAPLES	
	CREO MATERIAL	CREO MASS 6.508	ENGINEER G STAPLES	2022-MMM-DD
	CREO VOLUME 54.885	CREO DRAWING FILE NAME: 520-F35-9054-I	DRAFTER M ZASSO	2022-MMM-DD
	DO NOT SCALE DRAWING		CHECKED ---	2022-MMM-DD

UNIVERSAL SONAR MOUNT		
ASSEMBLY, 3.5" FOIL CLAMPS, INDEXED, COMPACT		
SIZE	CUSTOMER DRAWING/PART NO. ---	REV 1
DRAWING/PART NO. 520-F35-9054-I		
SCALE	0.750	SHEET 1 OF 2

4

3

2

1

CUSTOMER DRAWING/PART NO. ---
DRAWING/PART NO. 520-F35-9054-I
REV 1
SHT 1

A

4

3

2

1

REVISIONS
SEE SHEET 1

D

D

C

B

A

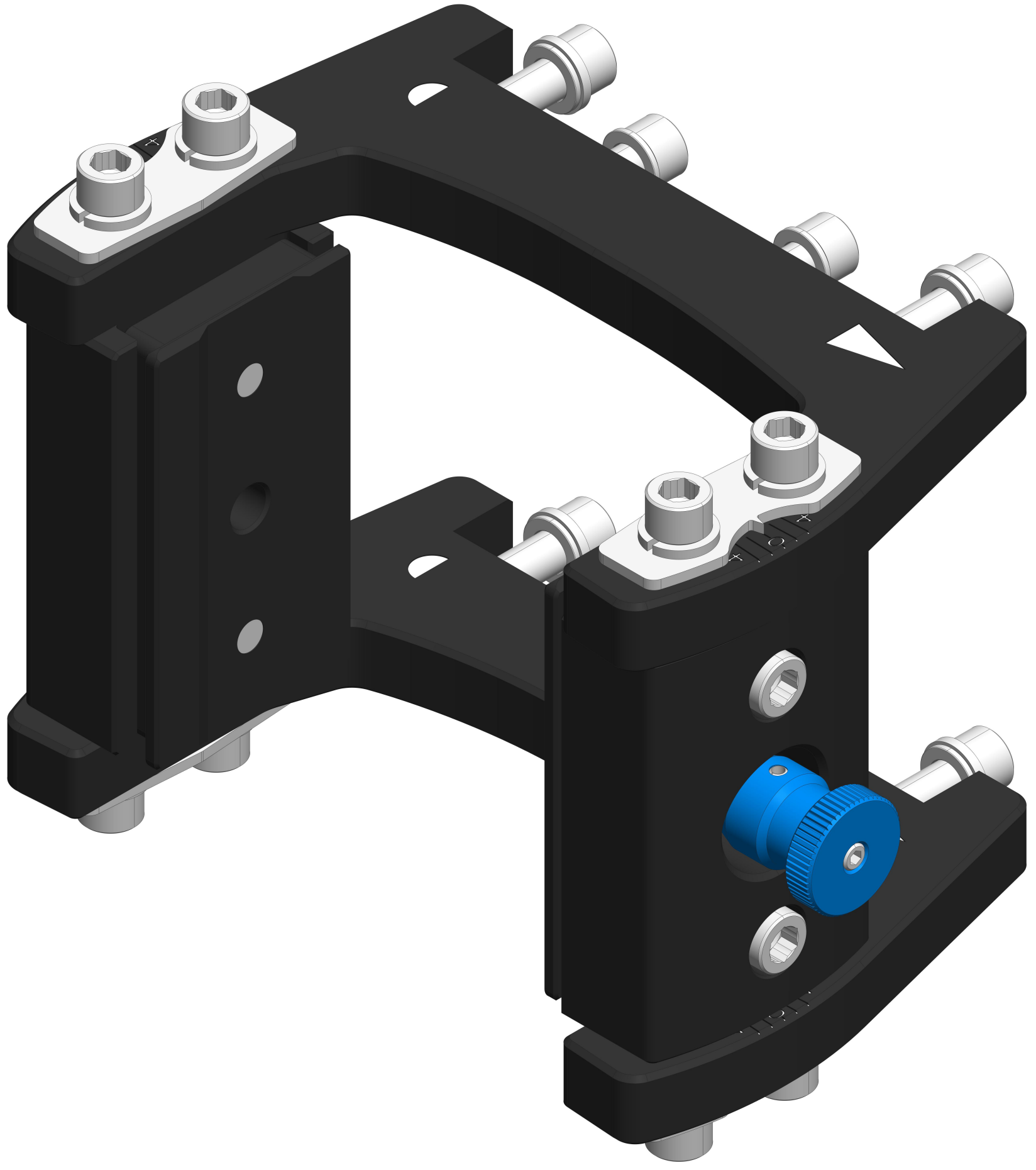

CUSTOMER DRAWING/PART NO.

DRAWING/PART NO.

520-F35-9054-I

REV

1

SHT

2

UNIVERSAL SONAR MOUNT		
ASSEMBLY, 3.5" FOIL CLAMPS, INDEXED, COMPACT		
SIZE	CUSTOMER DRAWING/PART NO.	REV
C	---	1
	DRAWING/PART NO. 520-F35-9054-I	
SCALE	1.000	SHEET 2 OF 2

4

3

2

1

A