

4

3

2

1

REVISIONS				
ZONE	REV	DESCRIPTION	DATE	APPROVED
--	1	INITIAL RELEASE	2022-AUG-15	MZ

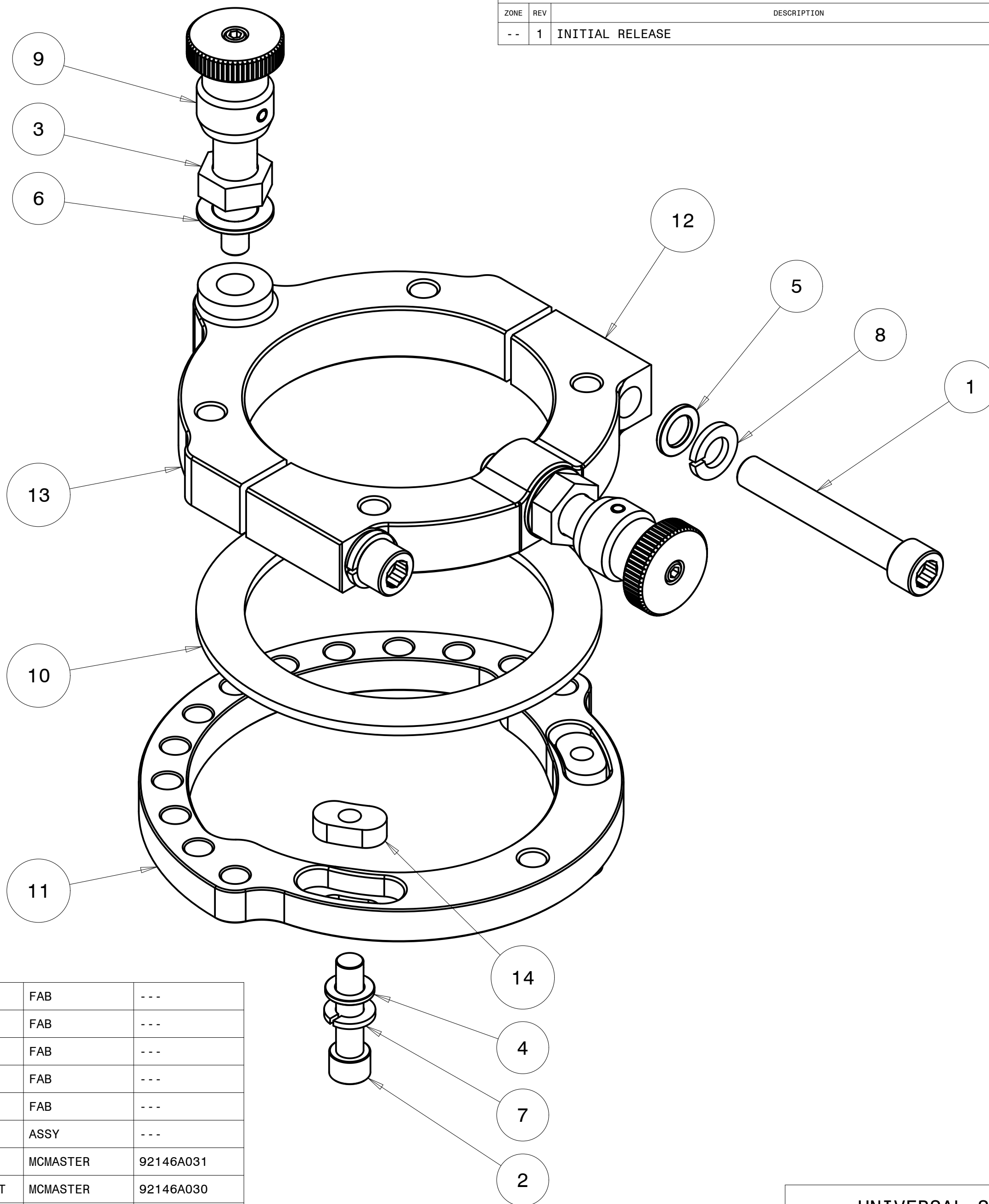

ITEM NO.	QTY REQD.	PART NO.	DRAWING TITLE OR DESCRIPTION	MANUFACTURER	MFG PART NO.
14	2	520-100-1039	NUT, PIN PLATE	FAB	---
13	1	520-100-1038-02	INDEX CLAMP HALF, -02	FAB	---
12	1	520-100-1038-01	INDEX CLAMP HALF, -01	FAB	---
11	1	520-100-1037	PIN PLATE, 15 DEG 3.5 Z POLE	FAB	---
10	1	520-100-1026	X POLE THRUST BUSHING, 3.5	FAB	---
9	2	501-9901-B	ASSY, LOCKING PULL PIN, BLUE, USM	ASSY	---
8	2	90-310-380-680-090-20	WASHER, SPLIT LOCK .380 ID X .68 OD X .090TK, 18-8 SST	MCMMASTER	92146A031
7	2	90-310-322-583-072-20	WASHER, SPLIT LOCK .322 ID X .582 OD X .072 TK, 18-8 SST	MCMMASTER	92146A030
6	2	90-300-515-875-060-20	WASHER, .515 ID X .875 OD X .060 18-8	MCMMASTER	98017A210
5	2	90-300-390-625-060-20	WASHER, .390 X .625 OD X .060 THICK, SST	MCMMASTER	98017A200
4	2	90-300-328-562-60-20	WASHER, .328 X .562 X .06 THICK SST	MCMMASTER	98017A690
3	2	90-201-500C-20	JAM NUT, 1/2-13 SST 18-8	MCMMASTER	91847A520
2	2	90-100-516C-1250-20	SCREW, 5/16-18 X 1.250 SHC 18-8	MCMMASTER	92196A585
1	2	90-100-375C-2500-20	SCREW, 3/8-16 X 2.50 SHC, SST 18-8	MCMMASTER	92196A634

UNLESS OTHERWISE SPECIFIED DIMENSIONS ARE IN INCHES. TOLERANCES ARE: .X +/- 0.1 .XX +/- 0.01 .XXX +/- 0.001 ANGLES +/- 0.5	CREO REPORTED PARAMETERS	DESIGNER G STAPLES	
	CREO MATERIAL	ENGINEER G STAPLES	2016-OCT-07
	CREO MASS 2.540	DRAFTER M ZASSO	2022-AUG-15
	CREO VOLUME 15.007	CHECKED ---	2022-MMM-DD
INTERPRET DIMENSIONS PER ASME Y14.5M 1994 (R2004)	CREO DRAWING FILE NAME: 520-100-9037	DO NOT SCALE DRAWING	

UNIVERSAL SONAR MOUNT		
ASSEMBLY, PAN INDEX, 3.5"		
SIZE	CUSTOMER DRAWING/PART NO.	REV
C	---	1
	520-100-9037	
SCALE	1.000	SHEET 1 OF 2

4

3

2

1

CUSTOMER DRAWING/PART NO. 520-100-9037

REV 1 SHT 1

A

4

3

2

1

REVISIONS
SEE SHEET 1

CUSTOMER DRAWING/PART NO.

DRAWING/PART NO.

520-100-9037

REV

1

SHT

2

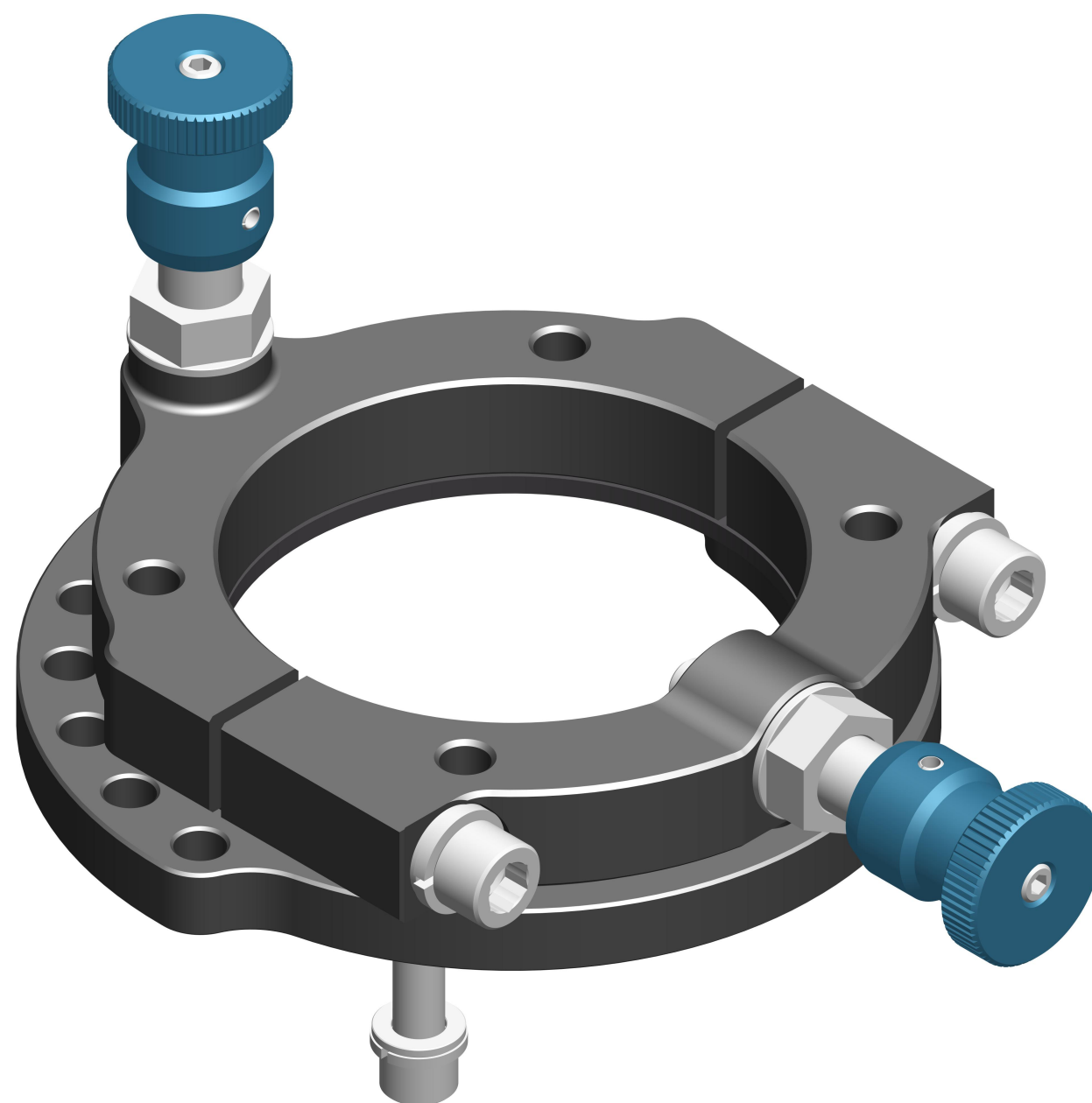

UNIVERSAL SONAR MOUNT		
ASSEMBLY, PAN INDEX, 3.5"		
SIZE	CUSTOMER DRAWING/PART NO.	REV
C	---	1
	DRAWING/PART NO. 520-100-9037	
SCALE	1.000	SHEET 2 OF 2

4

3

2

1

A

D

C

B

A

D

C

B

A