

REVISIONS				
ZONE	REV	DESCRIPTION	DATE	APPROVED
--	1	INITIAL RELEASE	02011-FEB-07	--
	2	UPDATED COLOR	02012-MAY-09	

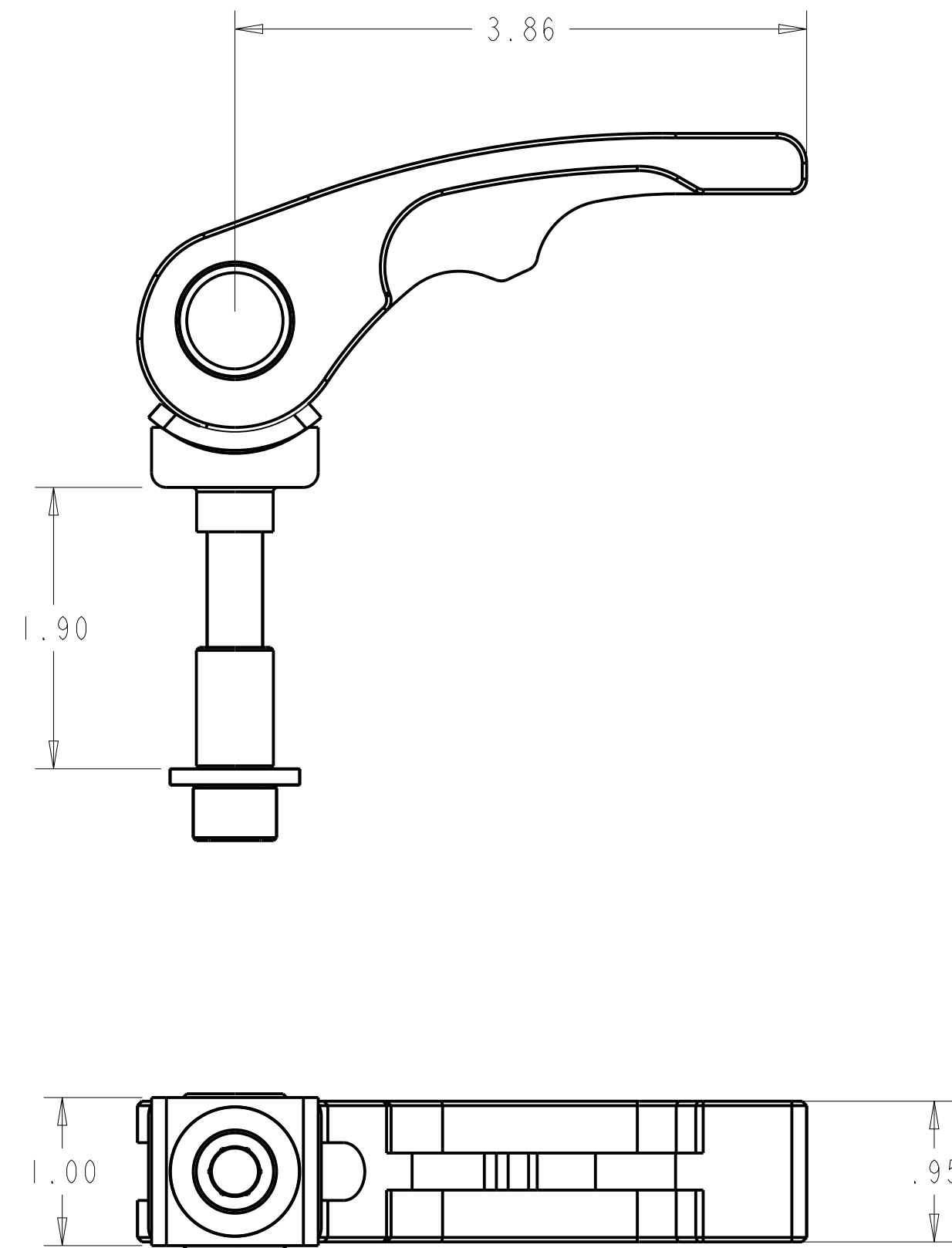
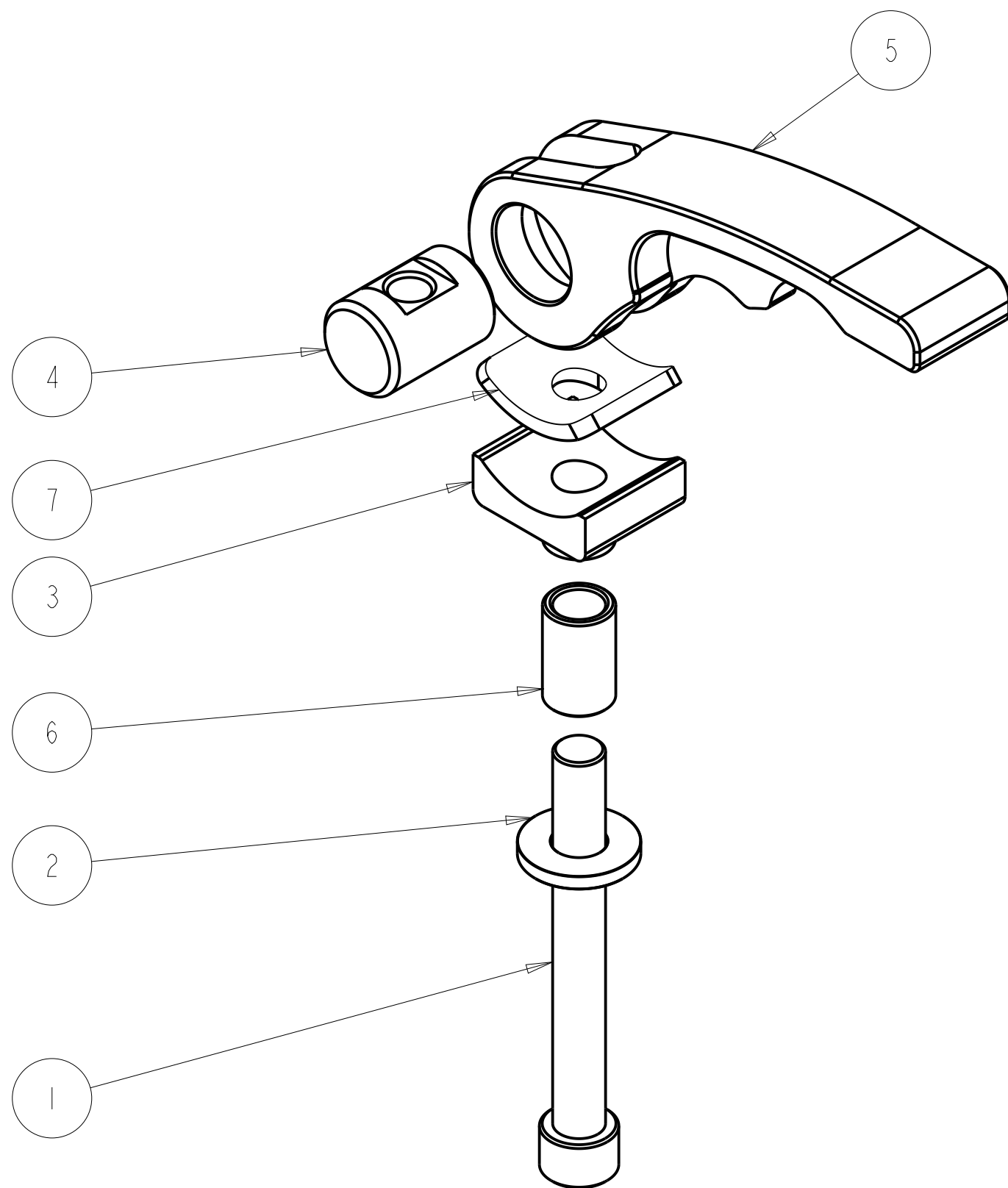

ITEM NO.	QTY RECD.	PART NO.	DRAWING TITLE OR DESCRIPTION	MANUFACTURER	MFG PART NO.
7	1	501-1445	SADDLE BEARING, OC LEVER, USM	FAB	---
6	1	501-1444	BUSHING, OC LEVER, USM	FAB	---
5	1	501-1443-R	LEVER, OC, SPINDLE CLAMP, USM, RED	FAB	---
4	1	501-1442	BARREL NUT, OC LEVER, USM	FAB	---
3	1	501-1441	SADDLE, OC LEVER, USM	FAB	---
2	1	90-300-406-875-110-21	WASHER, .406" ID X .875" OD X .110" TH, SST	MCMASTER	98370A030
1	1	90-100-375C-3250-20	SCREW, 3/8-16 X 3.25 SHC 18-8	MCMASTER	92196A637

UNLESS OTHERWISE SPECIFIED DIMENSIONS ARE IN INCHES. TOLERANCES ARE: .X +/- 0.1 .XX +/- 0.01 .XXX +/- 0.001 ANGLES +/- 0.5 INTERPRET DIMENSIONS PER ASME Y14.5M 1994 (R2004)	PRO/E REPORTED PARAMETERS		DESIGNER	
	PRO/E MATERIAL	G STAPLES		
	N/A	ENGINEER	GS	02011-FEB-07
	PRO/E MASS	1.995	DRAFTER	G STAPLES 02011-FEB-07
PRO/E VOLUME	N/A	CHECKED	---	02011-FEB-07
PRO/E DRAWING FILE NAME:	501-9440-02-R		DO NOT SCALE DRAWING	

UNIVERSAL SONAR MOUNT		
OC LEVER, SPINDLE CLAMP ,RED-USM		
SIZE	CUSTOMER DRAWING/PART NO.	REV
C	---	2
DRAWING/PART NO.		
501-9440-02-R		
SCALE	1.000	SHEET 1 OF 1

CUSTOMER DRAWING/PART NO. ---
 DRAWING/PART NO. 501-9440-02-R
 REV 2
 SH 1