

4

3

2

1

REVISION HISTORY			
ZONE	REV	DESCRIPTION	DATE/APPROVED
--	1	INITIAL RELEASE	
	2	VISUAL CHANGES / OVERALL LENGTH REDUCED	2022/02/01 MZ

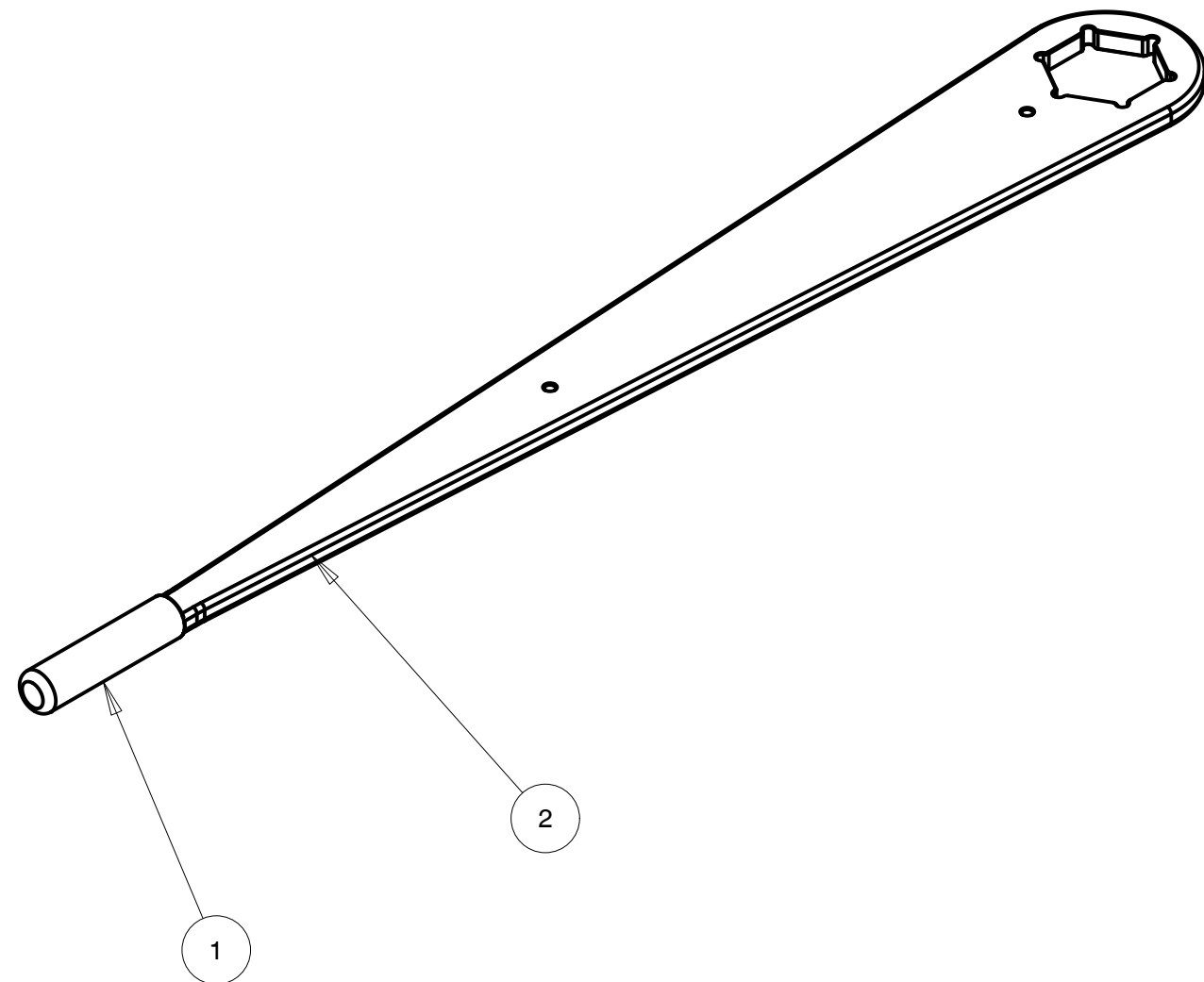

D

D

C

C

B

B

A

A

CUSTOMER DRAWING/PART NO. ---
 DRAWING/PART NO. 500-9600
 REV 2 SHT 1

ITEM NO.	QTY REQD.	PART NO.	DRAWING TITLE OR DESCRIPTION	MANUFACTURER	MFG PART NO.
2	1	500-1600	USM, WRENCH X POLE	FAB	---
1	1	500-1310	USM, HAND GRIP	FAB	---

UNLESS OTHERWISE SPECIFIED DIMENSIONS ARE IN INCHES. TOLERANCES ARE: .X +/- 0.1 .XX +/- 0.01 .XXX +/- 0.001 ANGLES +/- 0.5 INTERPRET DIMENSIONS PER ASME Y14.5M 1994 (R2004)	CREO REPORTED PARAMETERS		DESIGNER REASON BRADLEY	
	CREO MATERIAL	ENGINEER G STAPLES		2022-MMM-DD
	CREO MASS 4.380	DRAFTER G STAPLES		2022-MMM-DD
	CREO VOLUME 42.473	CHECKED ---		2022-MMM-DD
CREO DRAWING FILE NAME: 500-9600		DO NOT SCALE DRAWING		

UNIVERSAL SONAR MOUNT		
ASSEMBLY, USM X-POLE WRENCH		
SIZE	CUSTOMER DRAWING/PART NO. ---	REV 2
DRAWING/PART NO. 500-9600		
SCALE	0.250	SHEET 1 OF 2

4

3

2

1

4

3

2

1

REVISIONS
SEE SHEET 1

CUSTOMER DRAWING/PART NO.

DRAWING/PART NO.

500-9600

REV

2

SHT

2

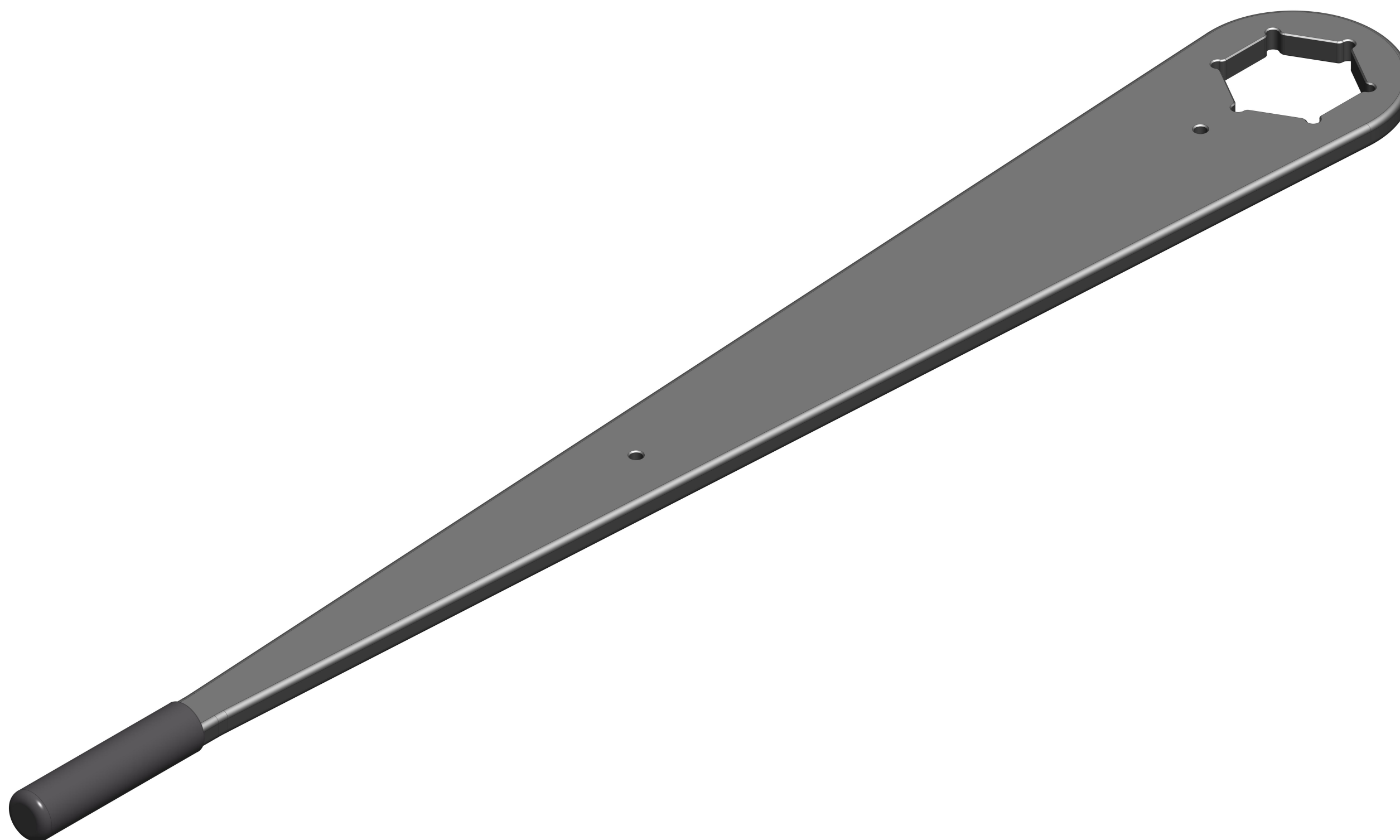

UNIVERSAL SONAR MOUNT		
ASSEMBLY, USM X-POLE WRENCH		
SIZE	CUSTOMER DRAWING/PART NO.	REV
C	---	2
	DRAWING/PART NO.	
	500-9600	
SCALE	0.500	SHEET 2 OF 2

4

3

2

1

A

D

C

B

A

D

C

B

A