

REVISIONS				
ZONE	REV	DESCRIPTION	DATE	APPROVED
--	1	INITIAL RELEASE	02018-JUL-30	- -

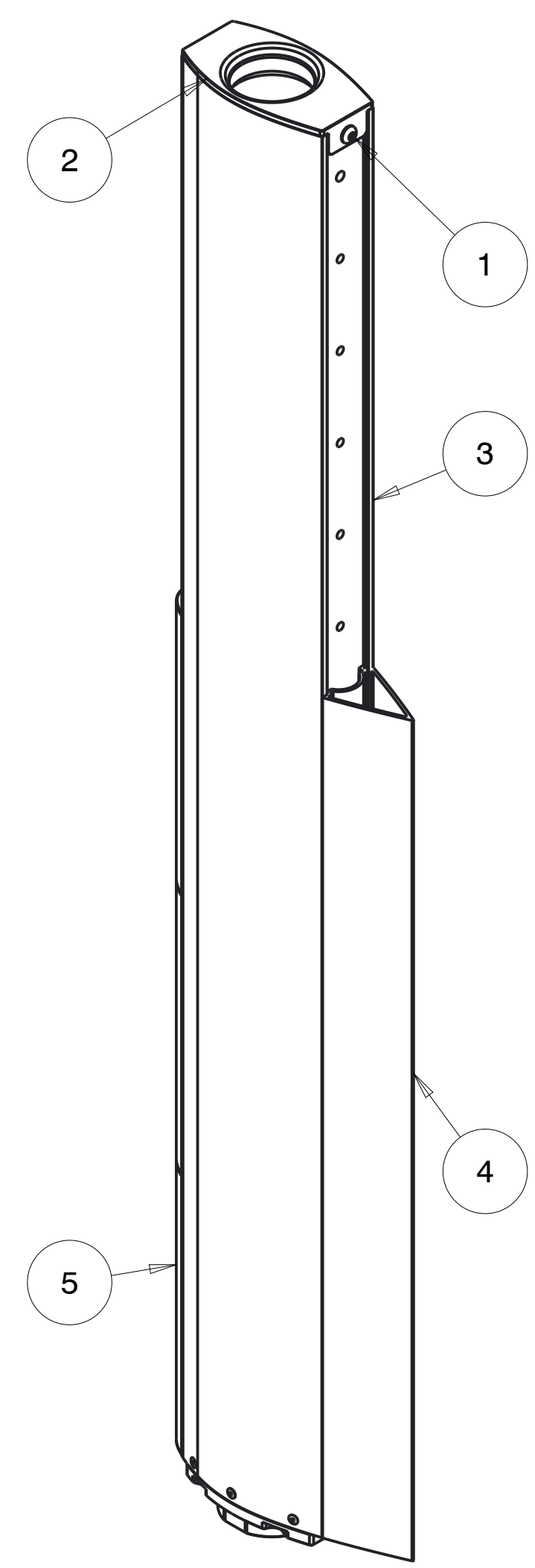
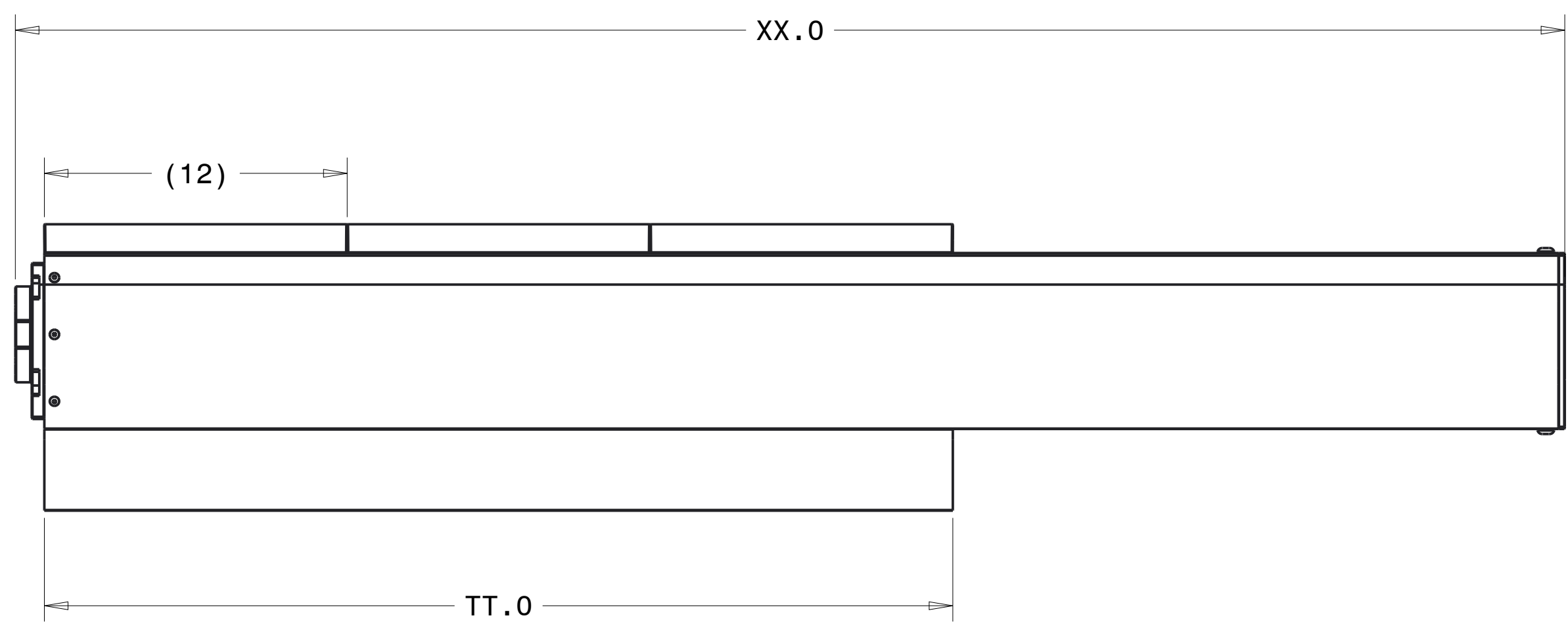

PART NO.	ITEM	MODIFIER
500-000-9010-XX	SECTION Z POLE LENGTH XX.0	
500-103-1011-04-TT	FOIL EXTENSION LENGTH TT.0	
520-103-1013	NOSE PICES (QTY OF 12 INCH LENGTHS)	

ITEM NO.	QTY REQD.	PART NO.	DRAWING TITLE OR DESCRIPTION	MANUFACTURER	MFG PART NO.	UNLESS OTHERWISE SPECIFIED DIMENSIONS ARE IN INCHES.	PRO/E REPORTED PARAMETERS	DESIGNER
5	3	520-103-1013	NOSE, COMPACT FOIL, 12IN	FAB	---	TOLERANCES ARE: .X +/- 0.1 .XX +/- 0.01 .XXX +/- 0.001 ANGLES +/- 0.5 INTERPRET DIMENSIONS PER ASME Y14.5M 1994 (R2004)	PRO/E MATERIAL	N UEBEL
4	1	500-103-1011-04-TT	FOIL PLASTIC EXTENSION, TT INCHES	FAB	---		N/A	ENGINEER N UEBEL 02018-JUL-30
3	1	500-000-9010-XX	ASSY, 4.0" FOIL W/ SHOE	ASSY	---		42.556	DRAFTER N UEBEL 02018-JUL-30
2	1	500-000-1013	CABLE GUIDE, 4.0" FOIL	FAB	---		N/A	CHECKED --- 02018-MMM-DD
1	2	90-130-375C-750-20	SCREW, 3/8-16 UNC X 3/4 BUTTON HEAD 18-8	MCMaster	92949A622		PRO/E DRAWING FILE NAME: 500-000-9010-XX-TT	DO NOT SCALE DRAWING

UNIVERSAL SONAR MOUNT		
ASSY, ONE-PIECE 4.0" FOIL		
SIZE	CUSTOMER DRAWING/PART NO.	REV
C	---	1
DRAWING/PART NO.		
500-000-9010-XX-TT		
SCALE	0.200	SHEET 1 OF 1

CUSTOMER DRAWING/PART NO. ---
 DRAWING/PART NO. 500-000-9010-XX-TT
 REV 1
 SHT 1