



BACK BARS - SWING DOORS



Features

- CFC free refrigerant and foam insulation
- Electronic thermostat and digital LED temperature display for accurate control and easy reading
- Stainless steel framework construction
- Magnetic door gaskets can be replaced without any tools
- Doors have lock and key
- Easy to mount 4" casters (two lockable in front) are standard with all units
- Mono-block unit
- Top: 430 stainless steel
- Interior: 430 stainless steel with 304 stainless steel floor
- Exterior: Heavy duty, wear resistant black paint
- Temperature: 33 to 41°F / 0.5 to 5°C
- Electrical: 115/60/1 with NEMA 5-15P plug
- KBB48-2G-24 contains : 48 x 6 pks of 12 oz. cans or 216 12 oz. bottles
- KBB60-2G-24 contains : 72 x 6 pks of 12 oz. cans or 324 12 oz. bottles
- KBB72-3G-24 contains : 84 x 6 pks of 12 oz. cans or 378 12 oz. bottles

Specifications

MODEL	DOORS	EXT DIMENSIONS W x D x H	INT DIMENSIONS W x D x H	AMPS	H.P.	SHIP WEIGHT
KBB48-2G-24	2	49.1 x 24.4 x 41.7	36 x 20.01 x 29.37	4.5	3/8	307 lbs
KBB60-2G-24	2	61.1 x 24.4 x 41.7	47.99 x 20.01 x 29.37	4.5	3/8	358 lbs
KBB72-3G-24	3	73.1 x 24.4 x 41.7	60 x 20.01 x 29.37	6	1/2	417 lbs

CERTIFIED TO ANSI/NSF-7 STANDARDS



Intertek

Intertek



5659 Royalmount Ave.
Montreal, QC, Canada H4P 2P9
Telephone: 514.737.9701 / Toll Free: 888.275.4538
Fax: 514.342.3854 / Toll Free: 877.453.8832
sales@mvpgroupcorp.com / mvpgroupcorp.com

12000 Biscayne Blvd., Suite # 108
Miami, FL, United States 33181
Telephone: 786.600.4687 / Toll Free: 844.218.8477
Fax: 786.661.4100



BACK BARS - SWING DOORS

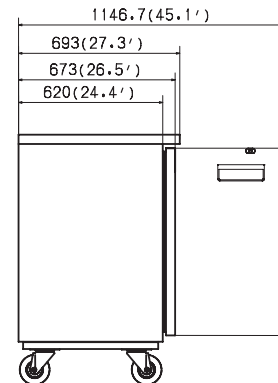
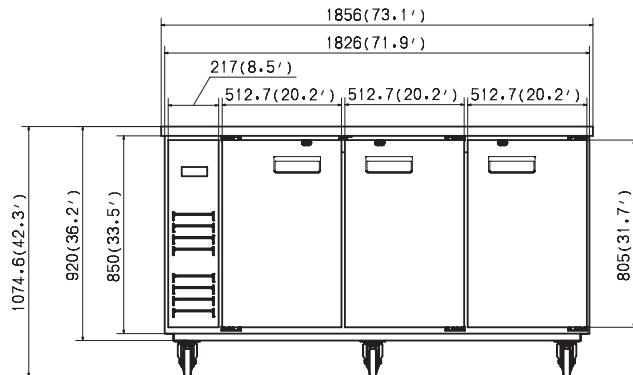
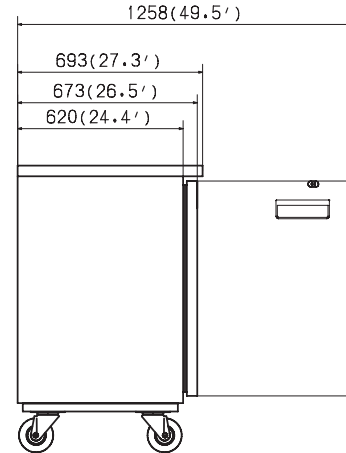
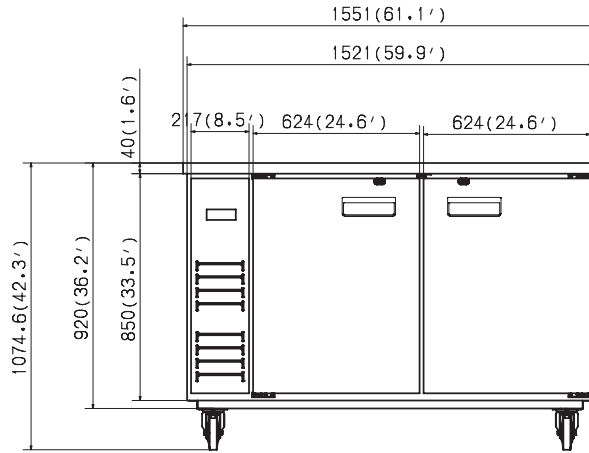
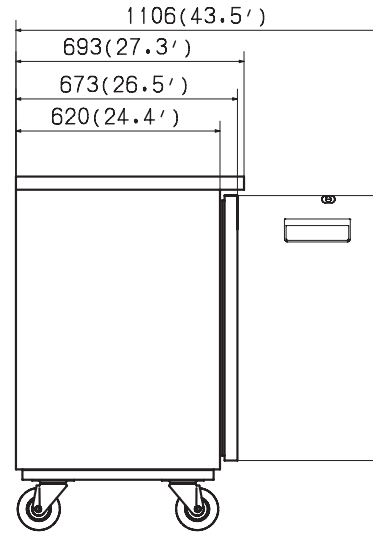
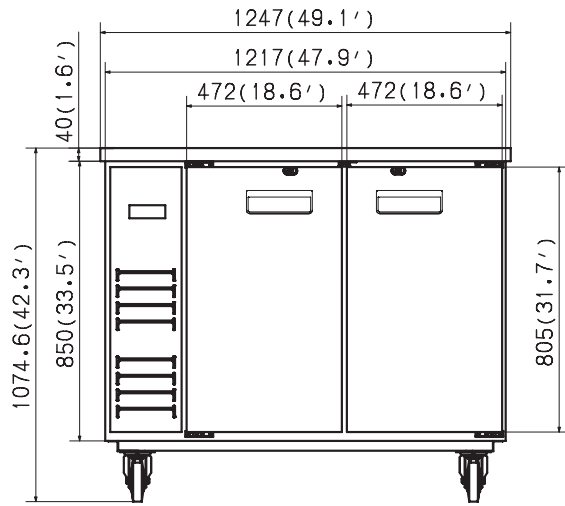

Dimensions in inches (mm)

CERTIFIED TO ANSI/NSF-7 STANDARDS



Intertek

Intertek



5659 Royalmount Ave.
 Montreal, QC, Canada H4P 2P9
 Telephone: 514.737.9701 / Toll Free: 888.275.4538
 Fax: 514.342.3854 / Toll Free: 877.453.8832
 sales@mvpgroupcorp.com / mvpgroupcorp.com

12000 Biscayne Blvd., Suite # 108
 Miami, FL, United States 33181
 Telephone: 786.600.4687 / Toll Free: 844.218.8477
 Fax: 786.661.4100