



**AX-M30  
30 QUART MIXER**



**PROJECT** \_\_\_\_\_  
**ITEM #** \_\_\_\_\_  
**QUANTITY** \_\_\_\_\_



The Axis Model AX-M30 is an advanced design, highly reliable professional food processing tool, and is ideal for mixing all types of dough, as well as eggs, cream, mayonnaise, etc. These all-purpose mixers use a powerful, planetary mixing action to thoroughly blend, mix and aerate all ingredients with consistent and predictable results.

**AX-M30  
30 QUART MIXER**

<b>STANDARD FEATURES</b>	<b>STANDARD ACCESSORIES</b>
<ul style="list-style-type: none"> <li>★ 1 HP motor</li> <li>★ Reliable and dependable gear drive design</li> <li>★ Digital timer (0-30 min)</li> <li>★ 3 speeds</li> <li>★ Heat-treated hardened alloy steel gears and shaft</li> </ul>	<ul style="list-style-type: none"> <li>★ 30 Quart S/S bowl</li> <li>★ Aluminum flat beater</li> <li>★ S/S wire whip</li> <li>★ Aluminum dough hook</li> </ul>
<ul style="list-style-type: none"> <li>★ Stainless steel bowl guard</li> <li>★ Side mounted controls (Timer, separate start and emergency stop button)</li> <li>★ Silent operation</li> <li>★ Highest quality aluminum alloy used for maximum standards of hygiene</li> <li>★ 6 foot cord and plug</li> </ul>	<p><b>OPTIONAL ACCESSORIES</b></p> <ul style="list-style-type: none"> <li>★ VS Attachment ( <i>housing only</i> )</li> <li>★ Disks avail. for VS Attachment: (Shredder, grater and slicer disks) <i>Sold separately</i></li> <li>★ Meat mincer attachment</li> </ul>



Model	Capacity	Motor	Amps	Speeds	Electrical
AX-M30	30 Quart	3 Speeds	15	115/214/390	110v / 60hz / 1ph

## TECHNICAL DRAWING

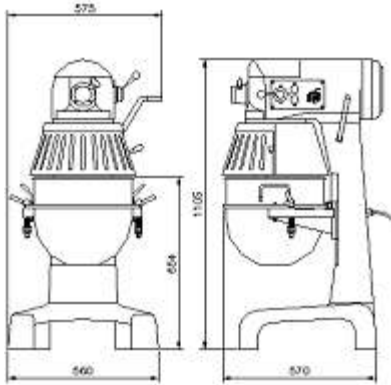

### DIMENSIONS

Overall Width	= 22.0" (560mm)
Overall Depth	= 22.4" (570mm)
Overall Height	= 43.5" (1105mm)

### WEIGHT

NET	= 319 lbs
SHIP	= 385 lbs

FREIGHT CLASS = 77.5

## SPECIFICATIONS

### ★ Design

Heavy duty all purpose mixers use a powerful, planetary mixing action to thoroughly blend mix and aerate all ingredients with consistent results.

### ★ Stainless Steel Bowl Guard

Safety interlock prevents operation when front portion of guard is open.

### ★ Three Fixed speeds

Consistency, flexibility and reliability. Excellent for incorporating, blending and mixing ingredients. Provides consistent results throughout mixing.

### ★ Gear Transmission

Ensures consistent performance and minimum downtime under heavy loads.

### ★ 1 H.P. Motor

Meets the most demanding operations.

### ★ Electronic Digital Timer

Provides accurate and consistent results while indicating the length of mixing (in minutes) on digital timer.

### ★ Warranty

2 year parts and 1 year labor, exclusive of wear items

Due to our continued product improvement and striving for engineering excellence, specifications are subject to change without notice

### MVP GROUP CORPORATION

5659 Royalmount Ave. Montreal, QC Canada H4P 2P9  
Tel: 514-737-9701 888-275-4538 Fax: 514-342-3854  
www.mvpgroupcorp.com / sales@mvpgroupcorp.com