

KOOL-IT *Signature*

LX-6RB SINGLE GLASS DOOR MERCHANDISER REFRIGERATOR

Energy efficient, eco-friendly HC refrigerant with low charge, spark-free components, and the lowest utility costs in its category.



DOE

NOM



NEMA 5-15P

Signature 40/80 Warranty
40 months parts and labor
80 months on compressor (part only)



3560 NW 56th Street
Fort Lauderdale, FL, United States 33309
Telephone: 786.600.4687 / Toll Free: 844.218.8477
Fax: 786.661.4100

5659 Royalmount Ave.
Montreal, QC, Canada H4P 2P9
Telephone: 514.737.9701 / Toll Free: 888.275.4538
Fax: 514.342.3854 / Toll Free: 877.453.8832
sales@mvpgroupcorp.com / mvpgroupcorp.com

KEY FEATURES



• Eco-Friendly Refrigerant

Environmentally friendly R600 hydrocarbon refrigerant has low Global Warming Potential (GWP). Meets all USA, California & Canada refrigerant & energy standards.



• Intelligent Electronic Control

Patented ETC1H electronic controller assures optimal refrigeration performance through precision temperature control, and intelligent control for defrost cycle, compressor & other component functions.



• High Power Reliable Refrigeration System

Fast pull down, optimal internal air circulation and reliable refrigeration, maintaining cooler temperatures for food preservation.



• Standard LED Lighting System

Ultra bright low energy interior LED illumination system provides optimal merchandise display visibility. Low profile, door mounted, clip-in LED design.



• Newly Designed Condenser

New condenser featuring a joints reduction down to zero increasing long term refrigeration reliability and safeguarding against any system leaks.



• Spark-Free Refrigeration Components

All Reach-In models have spark free refrigeration components for optimal safety, per UL requirements.



LX-6RB

SINGLE GLASS DOOR MERCHANDISER REFRIGERATOR

PRODUCT VIEWS

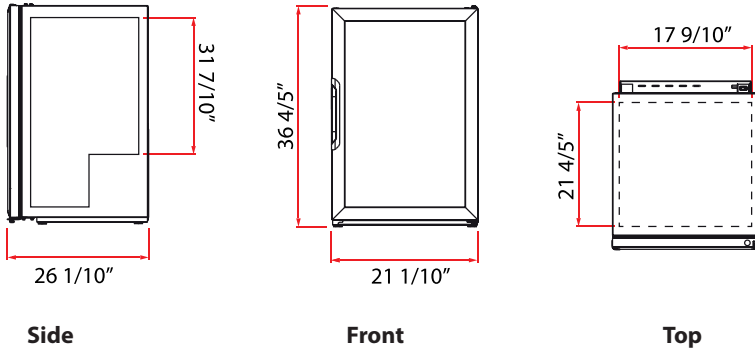

ADDITIONAL FEATURES



Manual Lock - External lock available



Gravity kit - Visi-Slide product display technology



Price Kit - Available for shelf display



Casters or legs are available options

TECHNICAL SPECIFICATIONS

Exterior Dimensions		Interior Dimensions	
W:	21 1/10" (54 cm)	W:	17 9/10" (46 cm)
D:	26 1/10" (66 cm)	D:	21 4/5" (55 cm)
H:	36 4/5" (93 cm)	H:	31 7/10" (80 cm)
Usable Interior Capacity		Usable Volume	
W:	16 7/10" (42 cm)	5.1 Cu Ft 144.4 L	
D:	16 2/5" (42 cm)		
H:	31 1/5" (79 cm)		
Doors	Material	Shelves	Shelf Size
1	NGD Plastic Frame	3	W: 17 1/10" (44 cm) D: 17 1/10" (44 cm)
Exterior Material		Pre-painted steel	
Interior Material		Pre-painted steel	

REFRIGERATION PERFORMANCE

Refrigerant	Energy Consumption
R600a / 1.2 oz (0.034 kg)	0.910 kWh/24h
Compressor Power	Condenser
1/8 HP	Finless (low maintenance)
Thermostat default setting	32°F (0°C) to 44.6°F (7°C)

ELECTRICAL

Power Supply	Amps	Lighting
115V/60Hz	2.2A	219.6 Lux Output 4 modules, 8 LED per
Plug Type	Controller	Cord Length
NEMA 5-15P	ETC1H	118" (300 cm)

LOGISTICS

Trailer Loads	Unit Weight	Shipping Dimensions	
53': 160	119 lb (54 kg)	W:	22 1/2" (57 cm)
	Shipping Weight	D:	29 2/5" (75 cm)
	124.6 lb (56.5 kg)	H:	37 3/5" (96 cm)