

# USER GUIDE & SERVICE MANUAL



Dispensers • UHDE215 • 15" Solid Door Cold Coffee Dispenser

**Tip:** Click on any section below to jump directly there

## Table of Contents

Intro

### Safety

Safety and Warning

Disposal And Recycling

### Installation

Environmental Requirements

Electrical

Cutout & Product Dimensions

Anti-Tip Bracket

General Installation

Grille Installation

Door Swing

Door Adjust

### Maintenance

Cleaning

Cleaning Condenser

Extended Non-Use

### Operating Instructions

First Use

Control Operation

Airflow and Product Loading

### Service

Troubleshooting

Wire Diagram

Product Liability

Warranty Claims

Parts

Ordering Replacement Parts

R600a Specifications

System Diagnosis Guide

Compressor Specifications

Troubleshooting Extended

Control Operation - Service

Defrost

Remove Fan and Cover

Warranty

## WELCOME TO U-LINE

Congratulations on your U-Line purchase. Your product comes from a company with over five decades of premium modular ice making, refrigeration, and wine preservation experience. U-Line continues to be the American leader, delivering versatility and flexibility for multiple applications including residential, light commercial, outdoor and marine use. U-Line's complete product collection includes Wine Captain® Models, Beverage Centers, Clear Ice Machines, Nugget Ice Machines, Crescent Ice Makers, Glass & Solid Door Refrigerators, Drawer Models, Freezers, Combo® Models, and more.

U-Line has captivated those with an appreciation for the finer things with exceptional functionality, style, inspired innovations and attention to even the smallest details. We are known and respected for our unwavering dedication to product design, quality and selection. U-Line is headquartered in Milwaukee, Wisconsin and has shipped product to five continents for over two decades and is proud to have the opportunity to ship to you.

## PRODUCT INFORMATION

Looking for additional information on your product? User Guides, Spec Sheets, CAD Drawings, Compliance Documentation, and Product Warranty information are all available for reference and download at [u-line.com](http://u-line.com).

## PROPERTY DAMAGE / INJURY CONCERNS

In the unlikely event property damage or personal injury is suspected related to a U-Line product, please take the following steps:

1. U-Line Customer Care must be contacted immediately at +1.800.779.2547.
2. Service or repairs performed on the unit without prior written approval from U-Line is not permitted. If the unit has been altered or repaired in the field without prior written approval from U-Line, claims will not be eligible.

## GENERAL INQUIRIES

U-Line Corporation  
8900 N. 55th Street  
Milwaukee, Wisconsin 53223 USA  
Monday - Friday 8:00 am to 4:30 pm CST  
T: +1.414.354.0300  
F: +1.414.354.7905  
Email: [sales@u-line.com](mailto:sales@u-line.com)  
[u-line.com](http://u-line.com)

## SERVICE & PARTS ASSISTANCE

Monday - Friday 8:00 am to 4:30 pm CST  
T: +1.800.779.2547  
F: +1.414.354.5696  
Service Email: [onlineservice@u-line.com](mailto:onlineservice@u-line.com)  
Parts Email: [onlineparts@u-line.com](mailto:onlineparts@u-line.com)

## CONNECT WITH US



Designed, engineered and assembled in WI, USA

## Safety and Warning

### NOTICE

**Please read all instructions before installing, operating, or servicing the appliance.**

Use this appliance for its intended purpose only and follow these general precautions with those listed throughout this guide:

### SAFETY ALERT DEFINITIONS

Throughout this guide are safety items labeled with a Danger, Warning, or Caution based on the risk type:



**Danger means that failure to follow this safety statement will result in severe personal injury or death.**



**Warning means that failure to follow this safety statement could result in serious personal injury or death.**



**Caution means that failure to follow this safety statement may result in minor or moderate personal injury, property, or equipment damage.**



**This unit contains R600a (Isobutane) which is a flammable hydrocarbon. It is safe for regular use. Do not use sharp objects to expedite defrosting. Do not service without consulting the “R600a specifications” section included in the User Guide. Do not damage the refrigerant circuit.**



**Service must be done by factory authorized service personnel. Any parts shall be replaced with like components. Failure to comply could increase the risk of possible ignition due to incorrect parts or improper service.**

### CALIFORNIA PROPOSITION 65

**This product contains chemicals known to the state of California to cause cancer and birth defects or other reproductive harm.**

[www.P65warnings.CA.gov](http://www.P65warnings.CA.gov)



**This equipment is to be installed with adequate backflow protection to comply with applicable federal, state and local codes.**

## Disposal and Recycling

 **DANGER**

**RISK OF CHILD ENTRAPMENT. Before you throw away your old refrigerator or freezer, take off the doors and leave shelves in place so children may not easily climb inside.**

If the unit is being removed from service for disposal, check and obey all federal, state, and local regulations regarding the disposal and recycling of refrigeration appliances, and follow these steps completely:

1. Remove all consumable contents from the unit.
2. Unplug the electrical cord from its socket.
3. Remove the door(s)/drawer(s).

## Environmental Requirements

This model is intended for indoor/interior applications only and is not to be used in installations that are open/exposed to natural elements.

This unit is designed to operate between 50°F (10°C) and 100°F (38°C). Higher ambient temperatures may reduce the unit's ability to reach low temperatures and/or reduce ice production on applicable models.

For best performance, keep the unit out of direct sunlight and away from heat generating equipment.

In climates where high humidity and dew points are present, condensation may appear on outside surfaces. This is considered normal. The condensation will evaporate when the humidity drops.



**Damages caused by ambient temperatures of 40°F (4°C) or below are not covered by the warranty.**

## Electrical



**SHOCK HAZARD – Electrical Grounding Required. Never attempt to repair or perform maintenance on the unit until the electricity has been disconnected.**

**Never remove the round grounding prong from the plug and never use a two-prong grounding adapter.**

**Altering, cutting or removing power cord, removing power plug, or direct wiring can cause serious injury, fire, loss of property and/or life, and will void the warranty.**

**Never use an extension cord to connect power to the unit.**

**Always keep your working area dry.**

### NOTICE

**Electrical installation must observe all state and local codes. This unit requires connection to a grounded (three-prong), polarized receptacle that has been placed by a qualified electrician.**

The unit requires a grounded and polarized 115 VAC, 60 Hz, 15A power supply (normal household current). An individual, properly grounded branch circuit or circuit breaker is recommended. A GFCI (ground fault circuit interrupter) is usually not required for fixed location appliances and is not recommended for your unit because it could be prone to nuisance tripping. However, be sure to consult your local codes.

See CUTOUT & PRODUCT DIMENSIONS for recommended receptacle location.

## Cutout & Product Dimensions

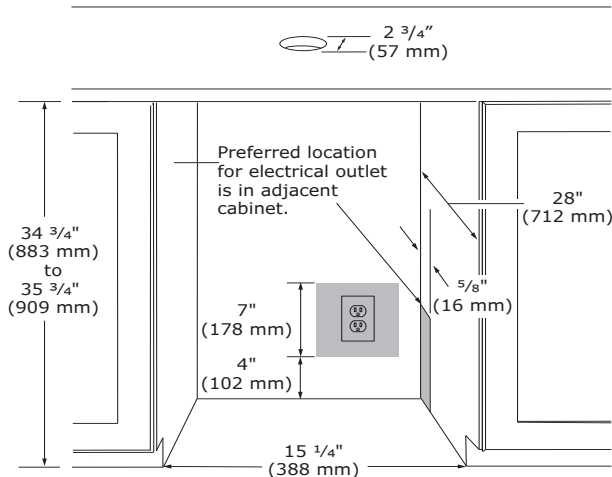
### PREPARE SITE

Your U-Line product has been designed for either free-standing or built-in installation. When built-in, your unit does not require additional air space for top, sides, or rear. However, the front grille must NOT be obstructed, and clearance is required for an electrical connection in the rear.



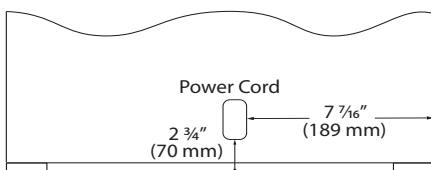
**Unit can NOT be installed behind a closed cabinet door.**

### CUTOUT DIMENSIONS

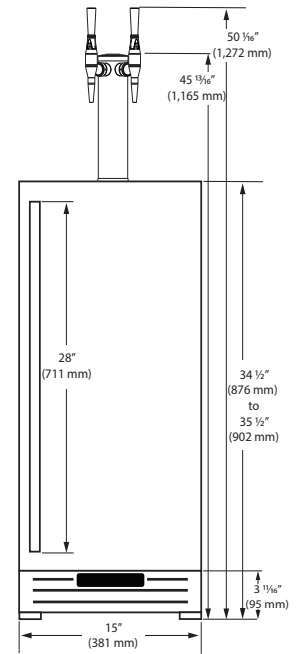


### PRODUCT DIMENSIONS

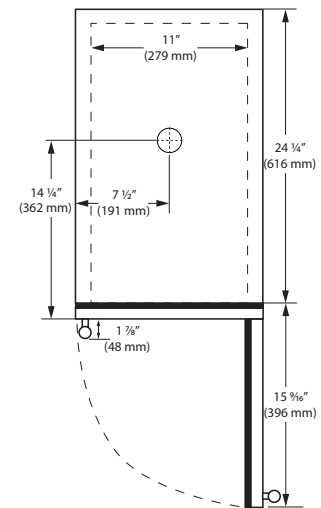
#### REAR



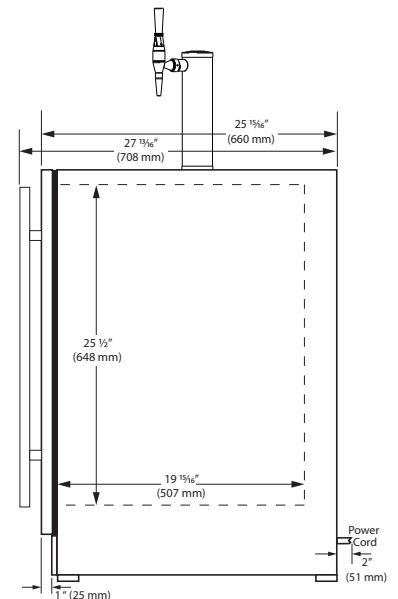
#### FRONT



#### TOP



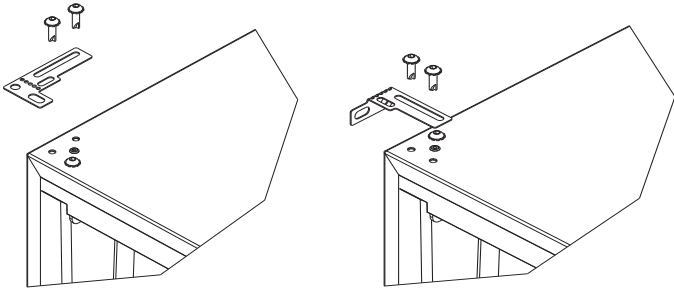
#### SIDE





## Anti-Tip Bracket

1. Slide unit out so screws on top of unit are easily accessible.
2. Remove the two screws from the opposite side of the hinge assembly using a T-25 Torx driver (see below).

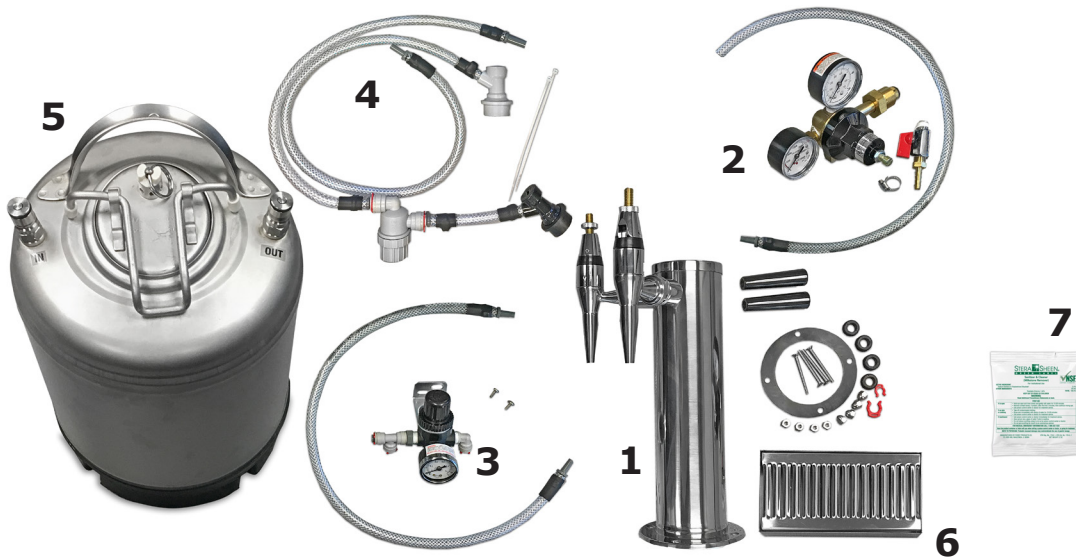


3. Place bracket over holes and attach to unit with two screws removed in step 2 using a T-25 Torx driver. Tighten screws fully.
4. Gently push unit into position. Be careful not to entangle the electrical cord or water line, if applicable.
5. Check to be sure the unit is level from front to back and side to side. Make any necessary adjustments. The unit's top surface should be approximately  $\frac{1}{8}$ " (3 mm) below the countertop.
6. Secure bracket into adjoining surface.

## General Installation

**The following components are shipped inside the unit:**

1. Double Tower (faucets, handles, gaskets, & hardware)
2. Nitrogen regulator (hose and valve)
3. Infuser regulator (hoses & hardware)
4. Liquid jumper line (with in-line filter) and gas jumper line
5. 2.5-gallon ball tap keg (you may use 3-gallon or 5-gallon keg)
6. Drip tray
7. Cleaning solution (2-ounce packet)  
(Additional cleaner, ULACOFFEECLEAN, is available at u-line.com)



**Required (not included):**

1. Nitrogen tank with food grade nitrogen - available at your local gas supplier. 22 cubic feet aluminum empty tank available (ULANITROTANK) at u-line.com.



### Safety and Warning



**Keep nitrogen tank in an upright position and handle with care.**

**Never exceed 60 PSI.**

**Ventilate area after nitrogen leak.**

2. Your favorite cold coffee or tea.

## Install Tower on Free-Standing Refrigerator

If your refrigerator is new out of the box, do not remove all the protective film on the stainless exterior until the tower is installed.

1. Remove four Phillips screws (secured with nuts on the inside of the refrigerator) and lift off cap to reveal tower mounting hole. Peel back enough film for tower to clear.



3. Screw the handles onto the faucets and continue to assemble and connect regulator to Nitrogen tank.



2. Position gasket over mounting hole and install tower using four Phillips screws and nuts.



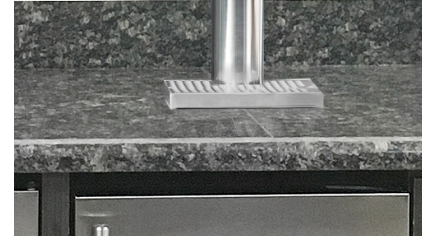
## Install Tower on Countertop

(See template on next page)

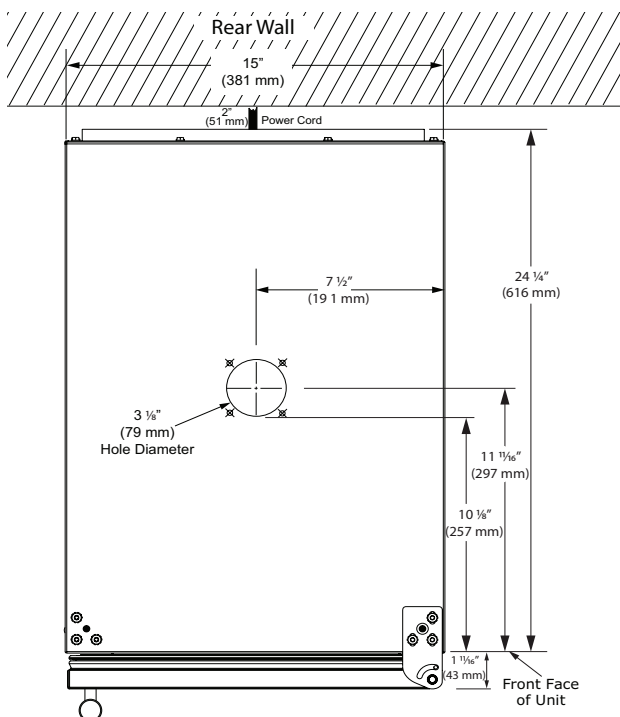
**Note:** These instructions are designed for a standard 36" countertop application.

**Note:** For a customized fit, it may be necessary to acquire screws that are sized to the thickness of your countertop.

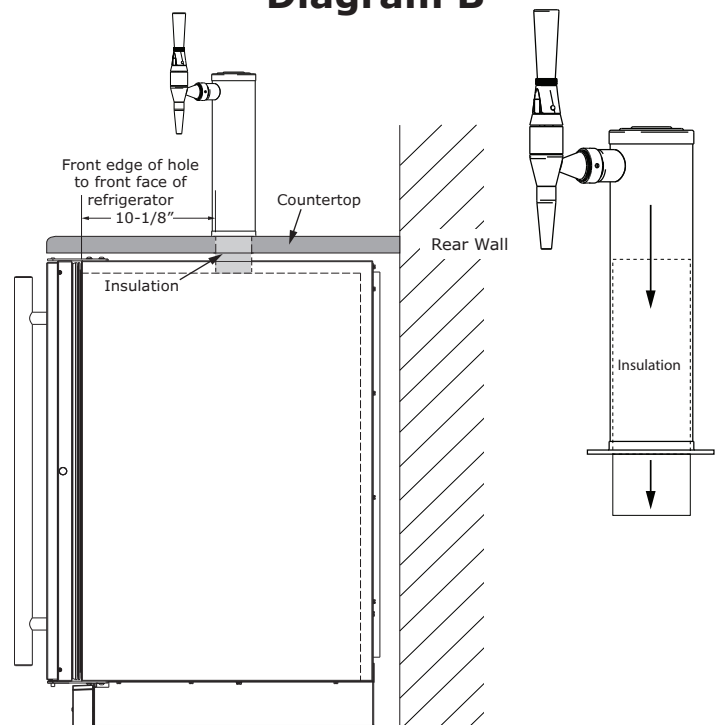
1. Position keg refrigerator under countertop to determine the desired depth.
2. Use the dimensions from Diagram A to determine the center point of the tower mounting hole.
3. Remove keg refrigerator from under countertop.
4. Use template to drill 4 mounting holes and drill 3-1/8" diameter hole through countertop.
5. Connect keg and infuser hoses to tower.
6. Pull down insulation inside tower far enough to extend into refrigerator - Diagram B.
7. Secure tower to countertop.
8. Remove 2 hole covers from top of refrigerator and inside ceiling of refrigerator.
9. Carefully slide refrigerator under countertop, taking care to insert hoses and insulation as you go.



**Diagram A**

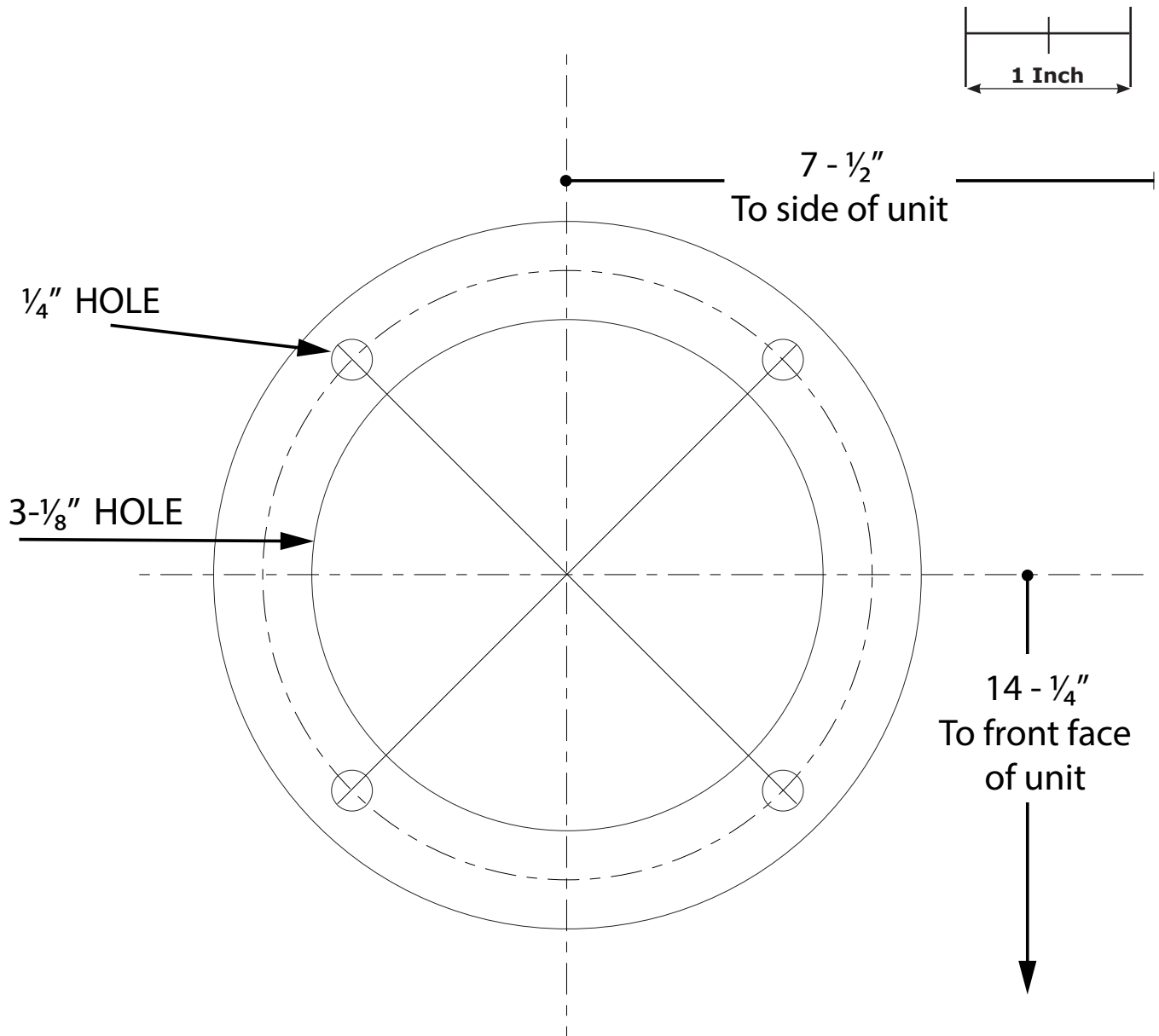


**Diagram B**



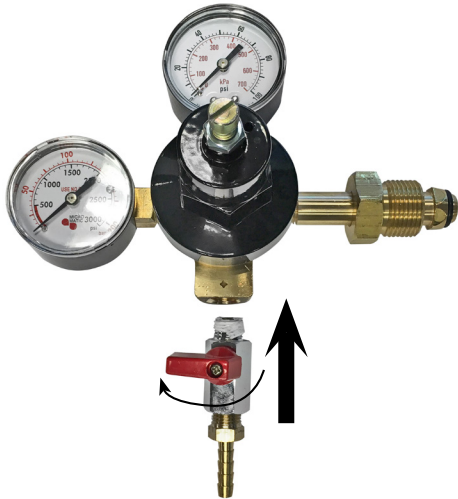
## Template for Countertop Installation

**Note: Verify template has printed true to scale - double check hole dimensions and placement.**

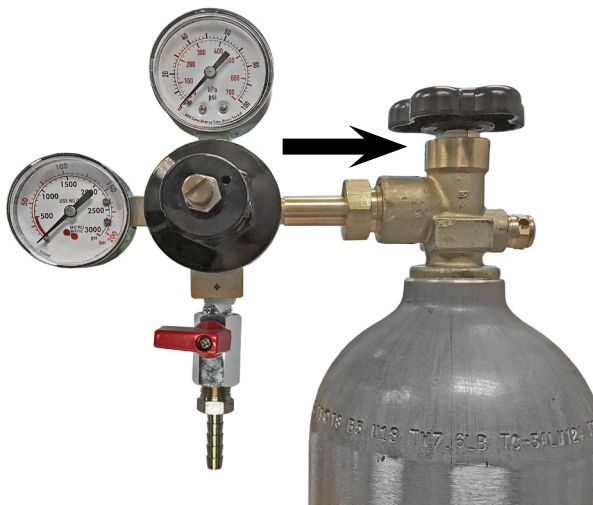


## Assemble and Connect Regulator to Nitrogen Tank

1. Attach ball valve to tank regulator. Tighten with an adjustable wrench. Make sure valve is in the off position - turned clockwise as far as it can go.

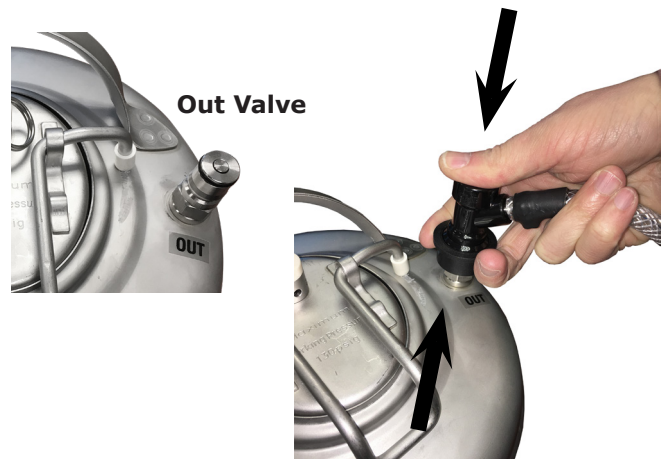


2. Attach regulator to nitrogen tank. Hand tighten the coupling nut and then use an adjustable wrench for an additional quarter turn. **DO NOT OVER TIGHTEN**

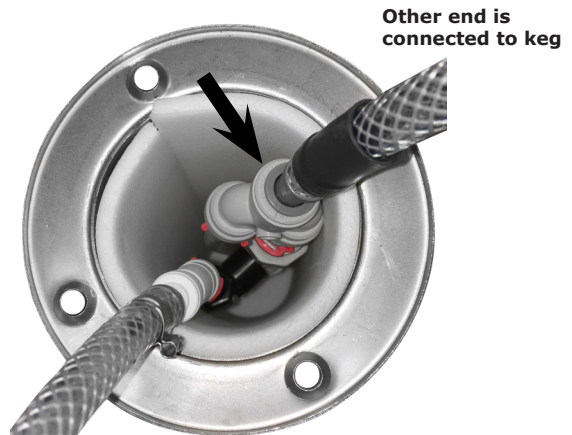


## Connect Keg to Dispenser Tower

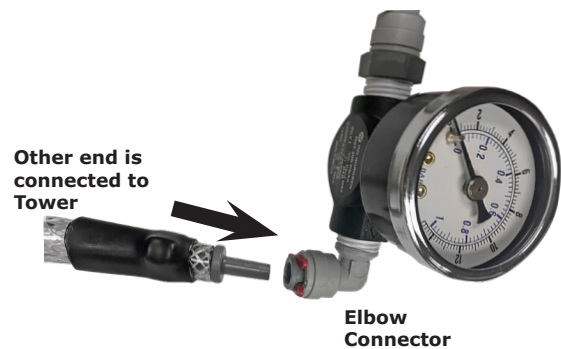
1. Attach black nitrogen coupler of the liquid jumper line to keg. With your thumb on top of the coupler, pull up on collar and press coupler down firmly onto out valve. Release collar - listen for a click. Pull up on the coupler to ensure it is locked down.



2. Attach other end of beverage hose to "Y" connection within dispenser tower - line up and press in firmly.



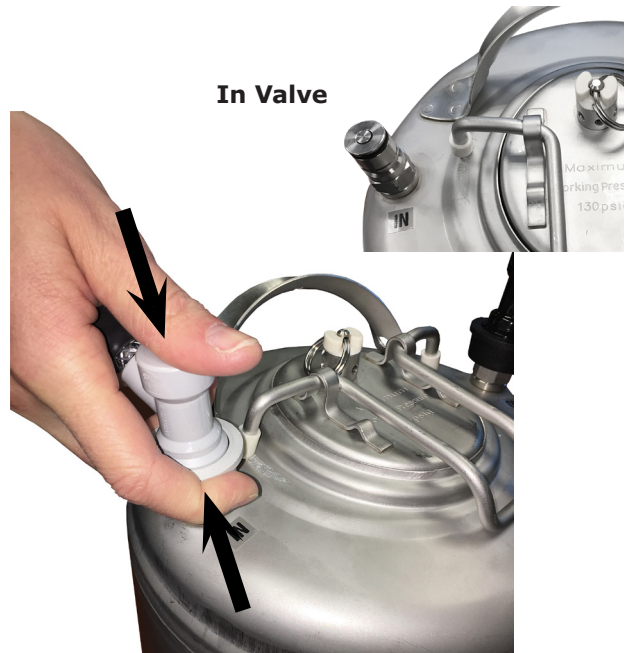
3. Attach hose to elbow connector on infuser regulator.



- Attach other end of hose to the single connection within the beverage tower.



- Attach gray coupler of the gas jumper line to keg. With your thumb on top of the coupler, pull up on collar and press coupler down firmly onto in valve. Release collar - listen for a click. Pull up on the coupler to ensure it is locked down.



## Connect Nitrogen Tank to Keg

- Attach nitrogen line to ball valve on tank regulator. Make sure valve is in the off position - turned clockwise as far as it can go. Tighten hose clamp.



- Attach other end of nitrogen line to T connector on infuser regulator - line up and press in firmly.

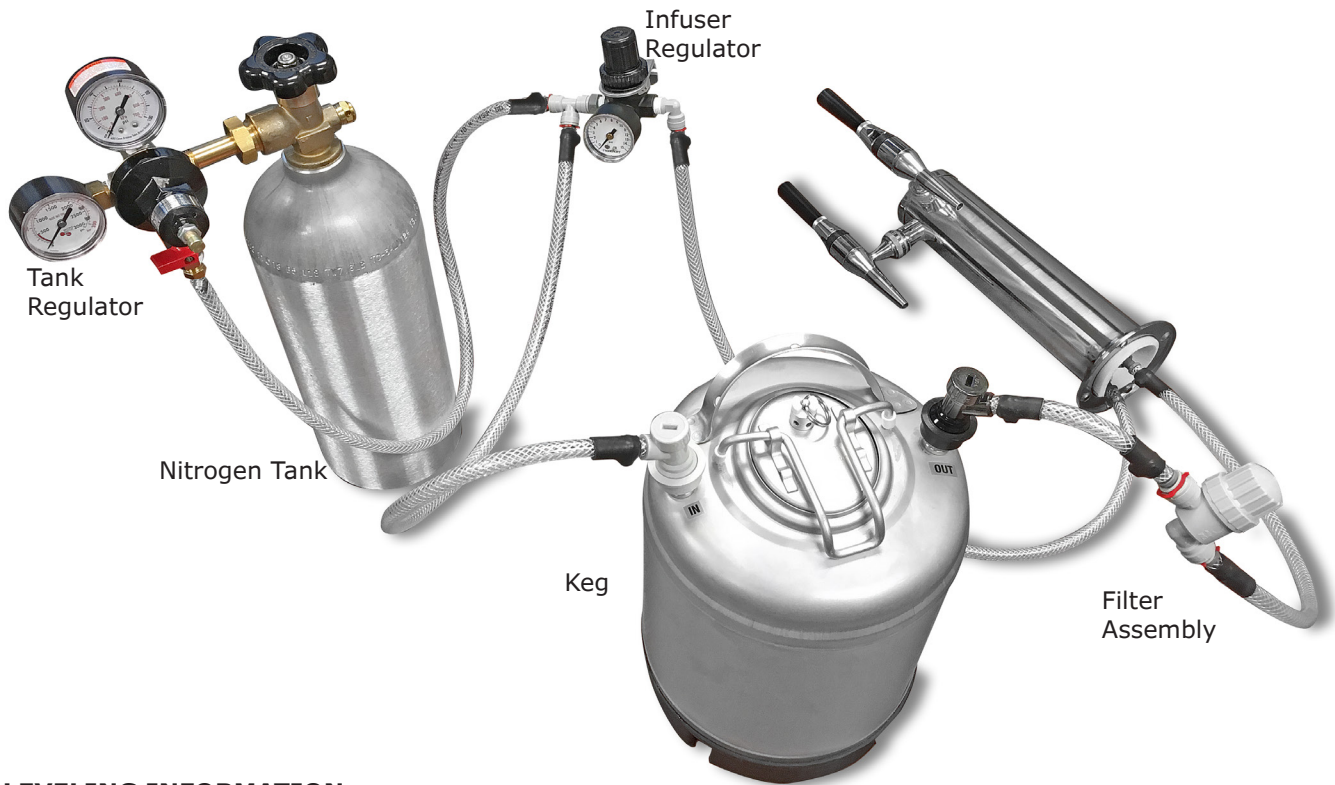


- Attach other end of gas jumper line to T connector on infuser regulator - line up and press in firmly.



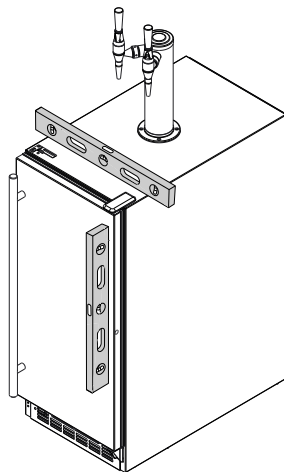
## Connections

When complete, the connections should look like this:



### LEVELING INFORMATION

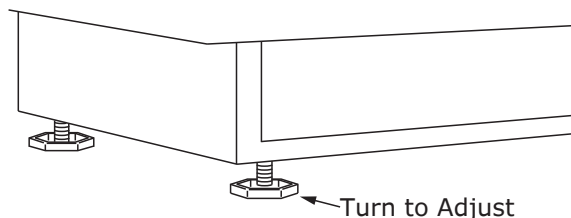
1. Use a level to confirm the unit is level. Level should be placed along top edge and side edge as shown.



2. If the unit is not level, adjust the legs on the corners of the unit as necessary.

3. Confirm the unit is level after each adjustment and repeat the previous steps until the unit is level.

When ready to use, see **FIRST USE** section in this manual.





## Grille Installation

### REMOVING AND INSTALLING GRILLE



**Disconnect electric power to the unit before removing the grille.**

**When using the unit, the grille must be installed.**

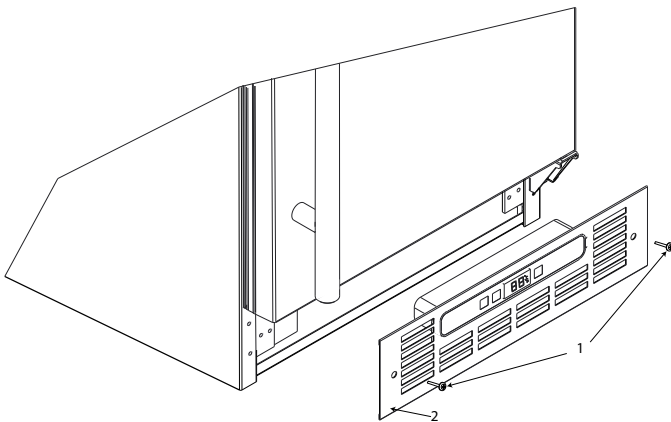
#### Removing the grille

**Note: Grille and display are attached. The length of the display wire is sufficient to allow access to the front base components.**

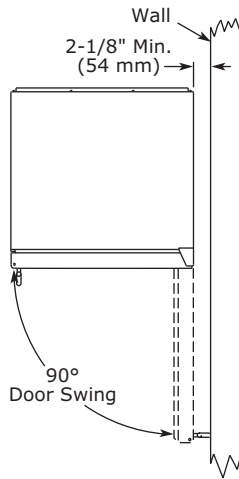
1. Disconnect power to the unit.
2. Loosen the two screws (1).
3. Remove grille (2) from unit.

#### Installing the grille

1. Align cabinet and grille holes and secure, but do not over tighten grille screws (1).
2. Reconnect power to the unit.



## Door Swing



Units have a zero clearance for the door to open 90°, when installed adjacent to cabinets.

Stainless Steel models require 2-1/8" (54 mm) door clearance to accommodate the handle if installed next to a wall.

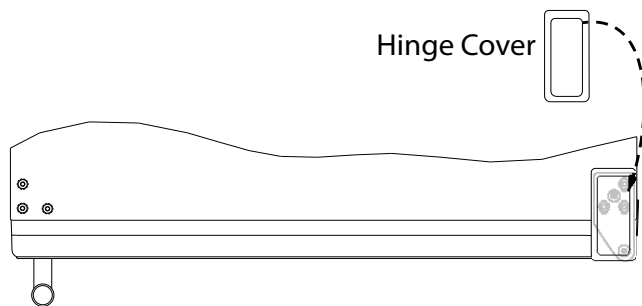
## Door Adjustments

### HINGE COVER

The hinge cover included with the literature bag is optional.

#### To install hinge covers:

1. Press hinge cover squarely over hinge.



### DOOR ALIGNMENT AND ADJUSTMENT

Align and adjust the door if it is not level or is not sealing properly. If the door is not sealed, the unit may not cool properly, or excessive frost may form in the interior.

#### NOTICE

**Properly aligned, the door's gasket should be firmly in contact with the cabinet all the way around the door (no gaps). Carefully examine the door's gasket to ensure that it is firmly in contact with the cabinet. Also make sure the door gasket is not pinched on the hinge side of the door.**

#### To align and adjust the door:

1. Gently pry off hinge cover from top of unit.
2. Loosen (do not remove) top and bottom hinge screws using a Philips screwdriver on the top and a 1/4" socket on the bottom.

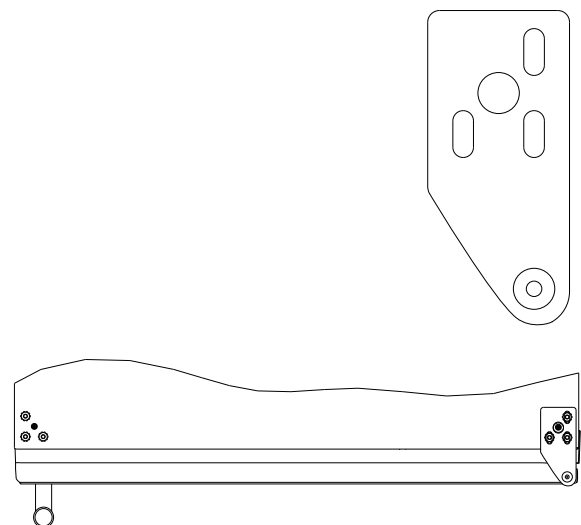
3. Align door squarely with cabinet.
4. Make sure gasket is firmly in contact with cabinet all the way around the door (no gaps).
5. Tighten bottom hinge screws.
3. Tighten top hinge screws and replace hinge cover.

### Reversing the Door

Location of the unit may make it desirable to mount the door on the opposite side of the cabinet.

The hinge hardware will be removed and reinstalled on the opposite side of the cabinet.

#### TO REVERSE THE DOOR

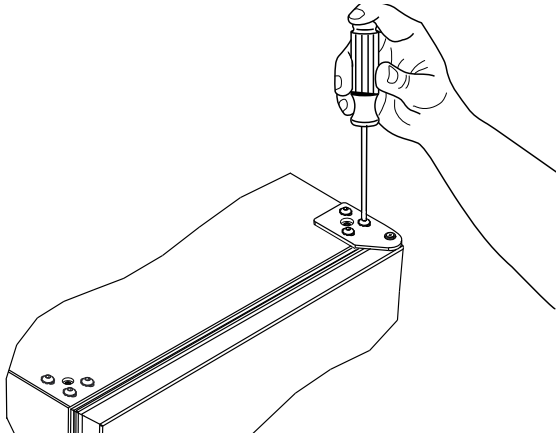


#### Remove grille:

Remove the grille (see GRILLE INSTALLATION section of this guide).

#### Remove top hinge and door:

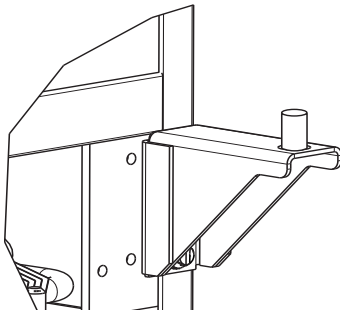
1. Remove hinge cover from top of unit.
2. Hold door to keep it from falling.
3. Remove top hinge from cabinet using a Philips screwdriver to remove three screws.
4. Use Philips screwdriver to remove hinge pin and reinstall on the opposite surface of the hinge.



4. Remove door by tilting forward and lifting door off bottom hinge. Retain shoulder washers; they will be reused.
5. Remove three screws from hinge holes on the opposite side. Reinstall into holes where the hinge was removed. Take care not to scratch cabinet.

### Remove bottom hinge:

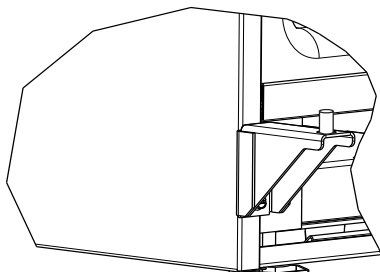
1. Remove bottom hinge from cabinet using 1/4" socket.



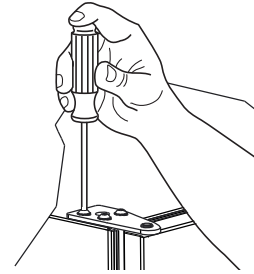
2. Remove corresponding screws on opposite side of cabinet. On some models there may be a nut behind one or both screws on either side.

### Install bottom hinge:

Install two or three screws, depending on model.  
 Replace nuts if used.



### Install top hinge and door:



1. Rotate door 180° and lift the door on to the bottom hinge.
2. Install hinge that was used on the opposite side of the unit
3. Align edge of the hinge with the outer edge of the unit while inserting hinge pin into top of door.
4. Tighten three screws and replace hinge cover.


### Align and adjust the door:

Align and adjust the door (see DOOR ALIGNMENT AND ADJUSTMENT).

### Install grille:

Install the grille.

## First Use

Initial startup requires no adjustments. If the unit was turned off, press and hold  for 5 seconds to turn unit on. See "Control Operation" section for more details.

### NOTICE

**Temperature displayed reflects actual temperature inside unit.**

If the temperature displayed is different than selected, the unit is progressing towards the selected temperature. Time to reach set point varies based upon ambient temperature, temperature of product loaded, door openings, etc. U-Line recommends allowing the unit to reach set points before loading.

To dispense cold coffee, make sure the components are assembled according to the instructions in GENERAL INSTALLATION.

4. Remove keg from refrigerator.
5. Lift handle and remove lid.



6. Fill keg with cold brew.
7. Replace and lock down lid.
8. Reattach hoses.

## Fill the Keg

### DE-PRESSURIZE SYSTEM

#### NOTICE

**Before attempting to fill the keg it is necessary to confirm system is not pressurized.**

1. Shut off nitrogen tank by turning handle clockwise until it stops.



2. Lift up on pressure release valve ring. Allow pressure to release.

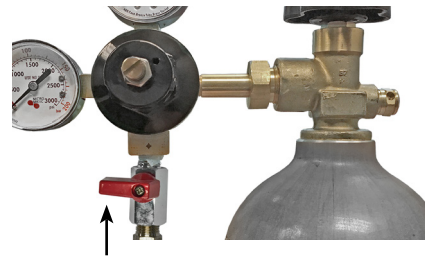


3. Detach hoses from keg. (See General Installation section of this guide.)

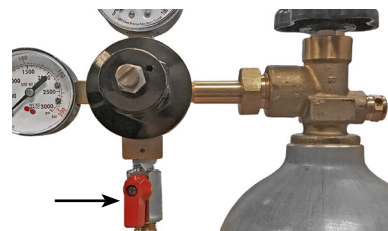
## Set Nitrogen Pressure

The pressure should be set around 20 - 30 PSI. Start at 25 PSI on regulated gauge; 7 PSI at infuser regulator.

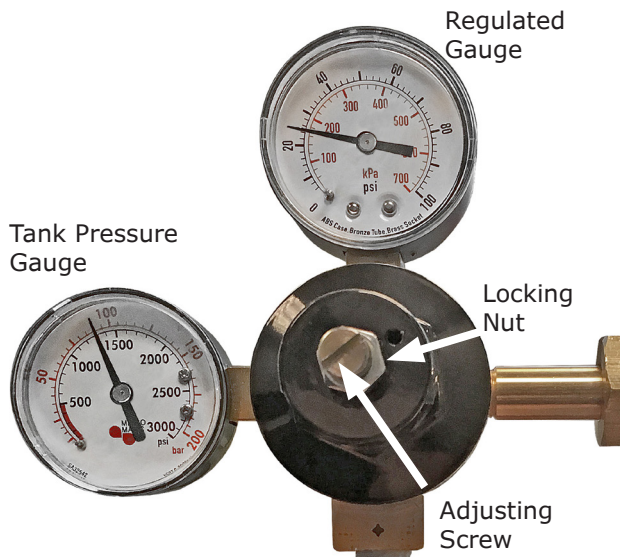
1. Make sure red regulator valve is in the OFF position.



2. On top of Nitrogen tank, turn black handle counterclockwise until it stops.
3. Rotate the red regulator valve to ON Position; turn counterclockwise 1/4 turn until it stops



4. To adjust pressure, loosen locking nut, turn adjusting screw until desired pressure is reached, and retighten locking nut.



5. On infuser regulator, pull out middle knob to unlock then turn knob until needle points at 7 - turn right to increase; left to decrease.



6. Once set, lock in place by pressing middle knob in until it clicks.

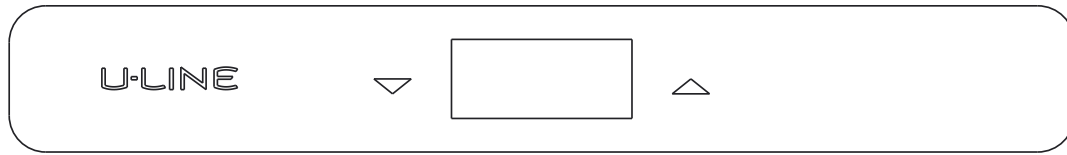
## Dispensing Coffee

The left tap delivers still cold brew which is refreshing and less acidic than hot coffee. The right tap delivers nitrogen-infused coffee which is the ultimate cold brew experience. Thousands of micro-nitrogen bubbles are infused as the coffee is dispensed. This creates a naturally slightly sweet taste and thicker and smoother texture.

## Troubleshooting

ISSUE	CAUSE	SOLUTION
No/reduced liquid flow through faucet(s).	The strainer inside of the filter bowl assembly is clogged or beginning to clog.	See cleaning section
	Nitrogen source is empty or turned off.	If applicable, assure that the nitrogen tank is not empty and that the nitrogen shutoff switch is in the on position (in-line with the tube). Also assure that the knob on top of the tank is turned all the way counterclockwise. If the tank is empty, replace it with a full one.
	Liquid and/or nitrogen ball lock disconnects are not fully connected to product tank.	Attach the liquid/nitrogen ball lock disconnects to the product tank. If they already appear to be connected, disconnect/reconnect them.
	The nose cone of the faucet is clogged.	Detach the nose cone assembly from the stout faucet by turning it counterclockwise. Remove the stainless steel restrictor disc and inspect the small holes to assure that none of them are clogged.
	The system is dirty and requires a thorough line cleaning/sanitizing procedure.	Follow the line cleaning procedure above to remove buildup and restore full flow.
Too much or not enough nitrogen being infused into the product (head is too big or too small).	The secondary regulator is set to a pressure that is either too high or low.	If there is less/more nitro effect than desired, use the black knob on the secondary regulator assembly to make a change. To adjust the secondary regulator, pull the black knob out until you feel a slight click. This is the adjustment mode. To increase the level of nitro, turn this knob clockwise. To decrease the level of nitro, turn the knob counterclockwise. Continue adjusting and pouring until the level of nitro meets your requirements. Once you have found your desired level of nitrogenation, push the black knob back in to lock it in place.
	The strainer inside of the filter bowl assembly is beginning to clog.	See cleaning section
	The system is dirty and needs cleaned.	See cleaning section
Liquid leak.	Loose connection, broken fitting/tube, or loose faucet, nose cone or filter bowl assembly.	Immediately turn the nitrogen off to the system, disconnect the quick disconnects from the product tank and call customer support for consultation to assess the system.
Nitrogen leak (system is using nitrogen even when faucets are closed).	Product tank lid is not sealed completely.	Remove the lid and reattach making sure that the lid is centered and sealed.
	Fitting is loose, disconnected, or broken.	Immediately turn the nitrogen off to the system, disconnect the quick disconnects from the product tank and call customer support for consultation to assess the system.
The product is pouring too warm/cold or is freezing in the lines.	Hot/Warm - The refrigeration is not plugged in or turned on.	Plug in the refrigerator and assure it is powered on.
	Frozen - The thermostat on the refrigeration needs adjusted.	See control section
	The condenser coil on the refrigeration is dirty and needs cleaned.	See condenser cleaning

## Control Operation



### CONTROL FUNCTION GUIDE

FUNCTION	COMMAND	NOTES
ON/OFF	Press ▼ and hold for 5 seconds	Unit will turn On or OFF
Adjust Temperature	Press ▲ or ▼ and release	When the display is flashing, press ▲ or ▼ to adjust the set point temperature. Note: temperature displayed is the actual temperature inside unit
Toggle between °F / °C	Hold ▲ and ▼ for 5 seconds	The display will change units



## Airflow and Product Loading

### **AIRFLOW**

#### **External**

- Do not block the front grille - no additional clearance around sides, top or rear of unit is needed for ventilation
- Do not install behind a closed door

#### **Internal**

- When loading, leave space between internal fans, vents, and side walls to allow air to circulate freely

### **NOTICE**

**Restricting airflow may result in poor product performance, product failure, and uneven internal temperatures and may freeze contents.**

## Cleaning

### Stainless Models

Stainless door panels, handles and frames can discolor when exposed to chlorine gas, pool chemicals, saltwater or cleaners with bleach.

Keep your stainless unit looking new by cleaning with a good quality all-in-one stainless steel cleaner and polish monthly. For best results use Claire® Stainless Steel Polish and Cleaner. Comparable products are acceptable. Frequent cleaning will remove surface contamination that could lead to rust. Some installations may require cleaning weekly.

**Do not clean with steel wool pads.**

**Do not use stainless steel cleaners or polishes on any glass surfaces.**

Clean any glass surfaces with a non-chlorine glass cleaner.

**Do not use cleaners not specifically intended for stainless steel on stainless steel surfaces (this includes glass, tile, and counter cleaners).**

If any surface discoloring or rusting appears, clean it quickly with Bon-Ami® or Barkeepers Friend Cleanser® and a nonabrasive cloth. Always clean with the grain. Always finish with Claire® Stainless Steel Polish and Cleaner or comparable product to prevent further problems.

**Using abrasive pads such as ScotchBrite™ will cause the graining in the stainless steel to become blurred.**

**Rust not cleaned up promptly can penetrate the surface of the stainless steel and complete removal of the rust may not be possible.**

### INTERIOR CLEANING

Disconnect power to the unit.

Clean the interior and all removed components using a mild nonabrasive detergent and warm solution applied with a soft sponge or non-abrasive cloth.

Rinse the interior using a soft sponge and clean water.

**Do not use any solvent-based or abrasive cleaners.** These types of cleaners may transfer taste and/or odor to the interior products and damage or discolor the interior.

### DEFROSTING

Under normal conditions this unit does not require manual defrosting. Minor frost on the rear wall or visible through the evaporator plate vents is normal and will melt during each cycle.

If there is excessive build-up of 1/4" (6 mm) or more, manually defrost the unit.

Ensure the door is closing and sealing properly.

High ambient temperature and excessive humidity can also produce frost.



**DO NOT use an ice pick or other sharp instrument to help speed up defrosting. These instruments can puncture the inner lining or damage the cooling unit. DO NOT use any type of heater to defrost. Using a heater to speed up defrosting can cause personal injury and damage to the inner lining.**

## NOTICE

**The drain pan was not designed to capture the water created when manually defrosting. To prevent water from overflowing the drain pan and possibly damaging water sensitive flooring, the unit must be removed from cabinetry.**

### To defrost:

1. Disconnect power to the unit.
2. Remove all products from the interior
3. Prop the door in an open position (2 in. [50 mm] minimum).
4. Allow the frost to melt naturally.
5. After the frost melts completely, clean the interior and all removed components.
6. When the interior is dry, reconnect power and turn unit on.

## Cleaning the System

The system should be cleaned each time you change your coffee tank and before extended periods of non use using a solution of water and ULACOFFEECLEAN. One packet of ULACOFFEECLEAN (Stera-Sheen®) was included with your product and more can be purchased at u-line.com.

### Notice

**Confirm system is not pressurized by turning off nitrogen – turn handle clockwise. Release pressure in system by pulling up on the release valve.**



## Cleaning Solution Preparation

Follow safety instructions on packet. Mix ULACOFFEECLEAN with 2 gallons of warm (100°F/38°C) potable water.



## Tap Heads

Clean the faucet with warm soapy water. Remove nose cone and soak in the cleaning solution for at least five minutes. Rinse with clean potable water, dry and reattach.



## Infuser Filter

Disassemble by unscrewing the cap. Rinse cap and filter with warm potable water and reassemble.



## Line and System Cleaning

1. Remove the contents, clean the keg with water warm soapy water, and rinse.
2. Pour the cleaning solution into keg, attach hoses and open the nitrogen valve to pressurize the system.
3. Place a bucket under the taps. Pull and hold the left tap open until approximately ½ gallon of cleaning solution is dispensed. Close the left faucet. Pull and hold the right faucet handle until ½ gallon of solution is dispensed. Discard solution.
4. Allow the cleaning solution to remain in the system for a minimum of five minutes.
5. Dispense approximately ¼ gallon of the solution through the left tap. Dispense the remaining solution from the right tap. No rinsing is required.
6. Unless refilling, remove lid from keg to allow keg to air dry.

## Cleaning Condenser

### **INTERVAL - EVERY SIX MONTHS**

To maintain operational efficiency, keep the front grille free of dust and lint, and clean the condenser when necessary. Depending on environmental conditions, more or less frequent cleaning may be necessary.

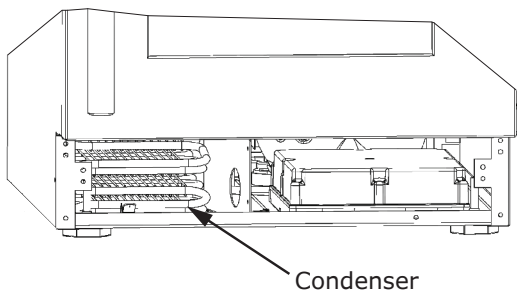
 **WARNING**

**Disconnect electric power to the unit before cleaning the condenser.**

### **NOTICE**

**DO NOT use any type of cleaner on the condenser unit. Condenser may be cleaned using a vacuum, soft brush, or compressed air.**

1. Remove the grille. See GRILLE INSTALLATION).
2. Clean the condenser coil using a soft brush or vacuum cleaner.
3. Install the grille.



## Extended Non-Use

### **VACATION/HOLIDAY, PROLONGED SHUTDOWN**

The following steps are recommended for periods of extended non-use:

1. Remove all consumable content from the unit.
2. Disconnect the power cord from its outlet/socket and leave it disconnected until the unit is returned to service.
3. If any ice is visible inside the unit, allow ice to thaw naturally.
4. Clean and dry the interior of the unit. Ensure all water has been removed from the unit.
5. Clean the system. (See CLEANING)
6. The door must remain open to prevent formation of mold and mildew. Open door a minimum of 2" (50 mm) to provide the necessary ventilation.

### **WINTERIZATION**

If the unit will be exposed to temperatures of 40°F (5°C) or less, the steps above must be followed.

**For questions regarding winterization, please call U-Line at 800.779.2547.**



**Damage caused by freezing temperatures is not covered by the warranty.**

## Troubleshooting

### BEFORE CALLING FOR SERVICE

If you think your U-Line product is malfunctioning, read the CONTROL OPERATION section to clearly understand the function of the control.

If the problem persists, read the NORMAL OPERATING SOUNDS and TROUBLESHOOTING GUIDE sections below to help you quickly identify common problems and possible causes and remedies. Most often, this will resolve the problem without the need to call for service.

### IF SERVICE IS REQUIRED

If you do not understand a troubleshooting remedy, or your product needs service, contact U-Line Corporation directly at +1.800.779.2547.

When you call, you will need your product Model and Serial Numbers. This information appears on the Model and Serial number plate located on the upper right or rear wall of the interior of your product.

### NORMAL OPERATING SOUNDS

All models incorporate rigid foam insulated cabinets to provide high thermal efficiency and maximum sound reduction for its internal working components. Despite this technology, your model may make sounds that are unfamiliar.

Normal operating sounds may be more noticeable because of the unit's environment. Hard surfaces such as cabinets, wood, vinyl or tiled floors and paneled walls have a tendency to reflect normal appliance operating noises.

Listed below are common refrigeration components with a brief description of the normal operating sounds they make. NOTE: Your product may not contain all the components listed.

- Compressor: The compressor makes a hum or pulsing sound that may be heard when it operates.

- Evaporator: Refrigerant flowing through an evaporator may sound like boiling liquid.
- Condenser Fan: Air moving through a condenser may be heard.
- Automatic Defrost Drain Pan: Water may be heard dripping or running into the drain pan when the unit is in the defrost cycle.

### TROUBLESHOOTING GUIDE

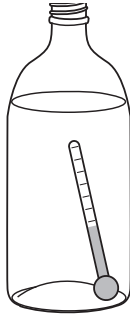


**ELECTROCUTION HAZARD. Never attempt to repair or perform maintenance on the unit before disconnecting the main electrical power.**

Troubleshooting - What to check when problems occur:

Problem	Possible Cause and Remedy
Interior Light Does Not Illuminate	If the unit is cooling, it may be in Sabbath mode.
Light Remains on When Door Is Closed.	Turn off light switch if equipped. Adjust light actuator bracket on bottom of door.
Unit Develops Frost on Internal Surfaces.	Ensure the door is closing and sealing properly.
Unit Develops Condensation on External Surfaces.	The unit is exposed to excessive humidity. Moisture will dissipate as humidity levels decrease.
Product is Not Cold Enough	Air temperature does not indicate product temperature. See CHECKING PRODUCT TEMPERATURE below. Adjust the temperature to a cooler set point. Ensure unit is not located in excessive ambient temperatures or in direct sunlight. Ensure the door is closing and sealing properly. Ensure the interior light has not remained on too long. Ensure nothing is blocking the front grille, found at the bottom of the unit. Ensure the condenser coil is clean and free of any dirt or lint build-up.

## CHECKING PRODUCT TEMPERATURE



### To check the actual product temperature in the unit:

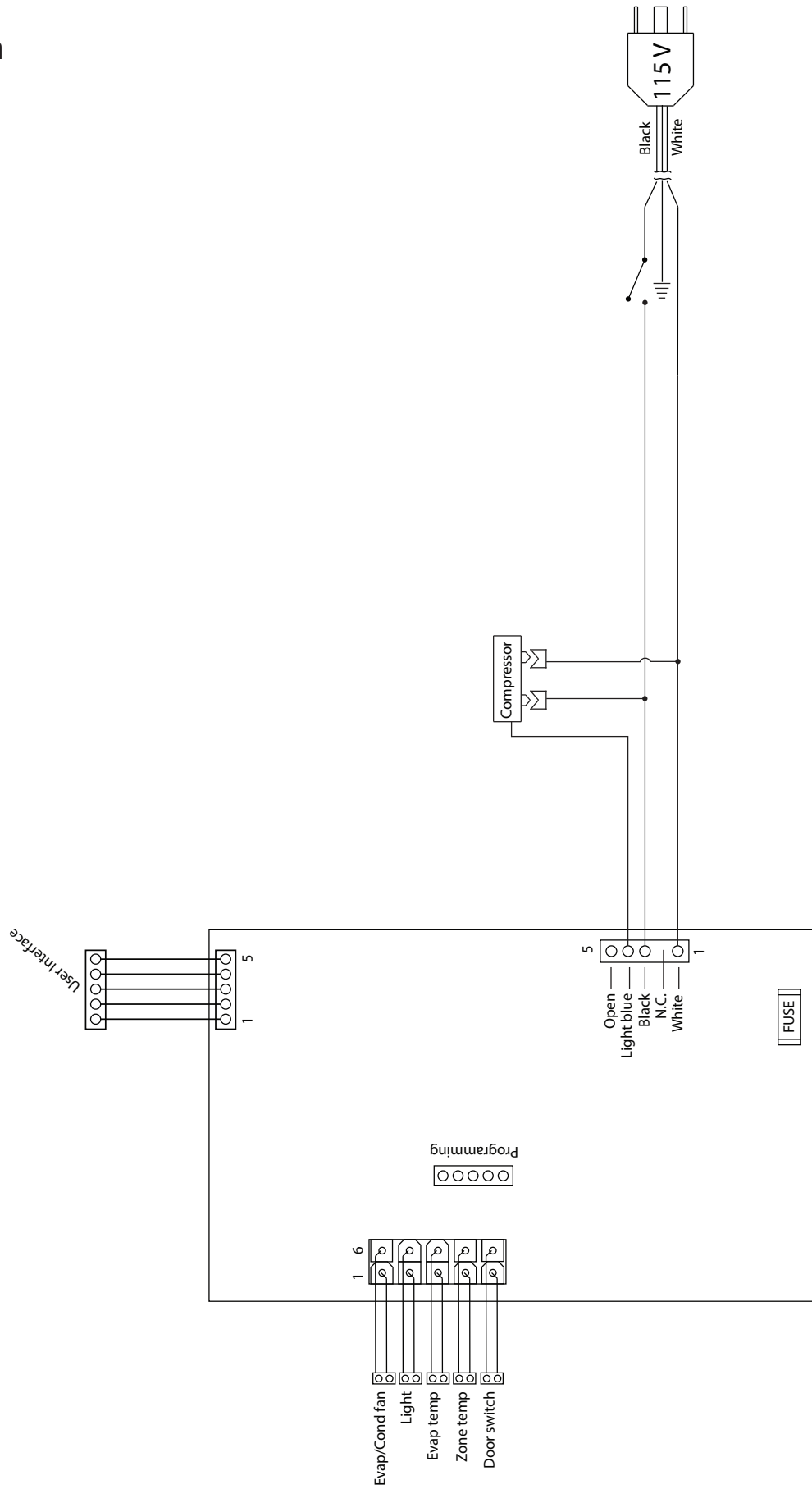
1. Partially fill a plastic (nonbreakable) bottle with water.
2. Insert an accurate thermometer.
3. Tighten the bottle cap securely.
4. Place the bottle in the desired area for 24 hours.
5. Avoid opening the unit during the testing period.
6. After 24 hours, check the temperature of the water.  
If required, adjust the temperature control in a small increment (see CONTROL OPERATION).

### Causes which affect the internal temperatures of the cabinet include:

- Temperature setting.
- Ambient temperature where installed.
- Installation in direct sunlight or near a heat source.
- The number of door openings and the time the door is open.
- The time the internal light is illuminated. (This mainly affects product on the top rack or shelf.)
- Obstruction of front grille or condenser.

Wire Diagram

42376\_B





## Product Liability

Field service technicians are authorized to make an initial assessment in the event of reported damages. If there are any questions about the process involved, the technician should call U-Line for further explanation.

While inspecting for defects or installation issues, photos should be taken to document any damages or issues found.

During the assessment, if the service technician is able to find the source of the damage and it can be resolved by replacement of a part, the servicer is authorized to replace the part in question. The part that caused the damage must be returned to U-Line in its entirety. The part must be clearly labeled with the serial number of the unit it was removed from, the date, and the servicer who removed the part.

If the service technician determines the damage is the result of installation issues (water connection/drain, etc.), the consumer would be notified and the issues shall be resolved at the direction of the consumer.

If damage is evident and the service technician is unable to find the source, U-Line must be contacted at 1.800.799.2547 for further direction.

8900 N. 55th Street • Milwaukee, WI 53223  
T: +1.414.354.0300 • F: +1.414.354.5696  
Website: [www.u-line.com](http://www.u-line.com)

**Right product. Right place.  
Right temperature Since 1962.**

## Warranty Claims

The following information defines the parameters for filing a warranty claim:

- Valid serial number needed
- Valid model number needed
- Claims must be submitted online at [www.U-LineService.com](http://www.U-LineService.com)
- 60 day submittal deadline from date of completed service
- Only one repair or unit per warranty claim
- Part order numbers will be required when submitting for warranty labor

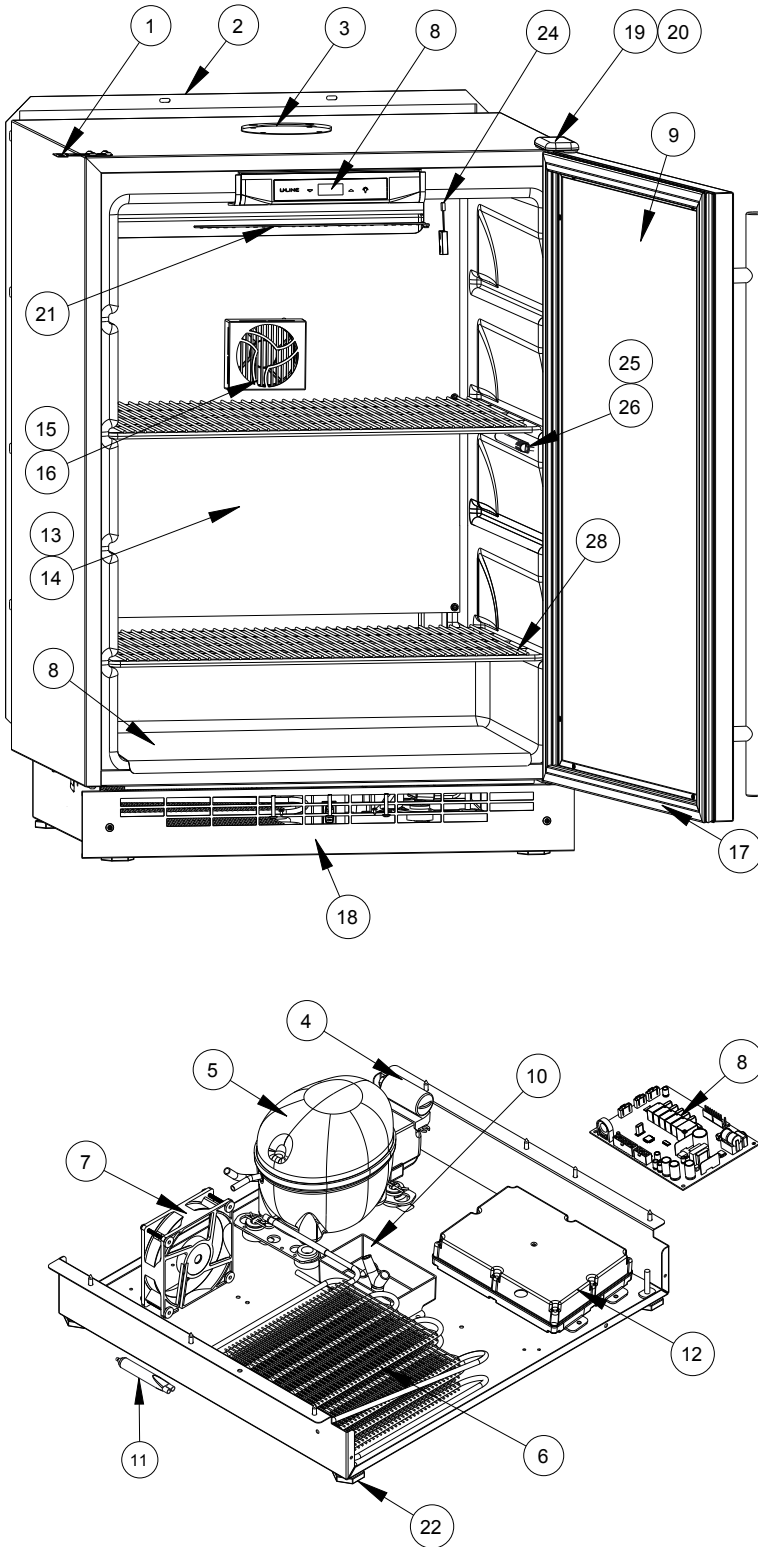
Units must be registered prior to warranty submittal. Customers may register at [www.U-Line.com](http://www.U-Line.com). A proof of purchase is required. We also accept the following information to update warranty:

- New construction occupancy documents
- Closing paperwork
- Final billing - Remodel

Warranty parts will be shipped at no charge after U-Line confirms warranty status. Please provide the model, serial number, part number and part description. Some parts will require color or voltage information.

17 14862 05 0527  
Year      Factory      Month      Factory  
            use Only                      use Only

Parts



UOKR124-SS01A		
1	ANTI-TIP BRACKET	80-54244-00
2	BACK PANEL	80-54204-00
3	CAP ASSEMBLY W/GASKET	80-54940-00
4	COMPRESSOR ELECTRICALS ONLY	80-54149-00
5	COMPRESSOR W/ELECTRICALS	80-54150-00
6	CONDENSER ASSEMBLY	80-54212-00
7	CONDENSER FAN W/SCREWS	80-54014-00
8	DISPLAY/MAIN BOARD ASSEMBLY	80-55533-00
9	DOOR ASSEMBLY	80-55421-00
10	DRAIN PAN	80-54217-00
11	DRIER	80-54055-00
12	ENCLOSURE ASSEMBLY	80-54532-00
13	EVAPORATOR ASSEMBLY	80-55411-00
14	EVAPORATOR COVER	80-55513-00
15	EVAPORATOR FAN	80-54321-00
16	EVAPORATOR FAN COVER	80-54320-00
17	GASKET, DOOR	80-55498-00
18	GRILLE ASSEMBLY	80-55412-00
19	HINGE ASSEMBLY	80-55418-00
20	HINGE COVER	80-55499-00
21	LED LIGHT STRIP AND COVER	80-54000-00
22	LEG LEVELERS (4)	80-54019-00
23	POWER CORD*	80-55401-00
24	REED SWITCH ASSEMBLY	80-54284-00
25	THERMISTOR	80-54006-00
26	THERMISTOR COVER	80-54237-00
27	WIRE HARNESS*	80-55402-00
28	WIRE SHELF (1)	80-54329-00

\*NOT SHOWN

## Ordering Replacement Parts

**Parts may be ordered online at [www.U-Line.com](http://www.U-Line.com)**

See our contact information below:

[www.U-LineService.com](http://www.U-LineService.com) (with service login)

Phone Number: +1.800.779.2547

### **NOTICE**

**Use only genuine U-Line replacement parts. The use of non-U-Line parts can reduce speed of ice production, cause water to overflow from ice maker mold, damage the unit, and void the warranty.**

Warranty parts will be shipped at no charge after U-Line confirms warranty status. Please provide the model, serial number, part number and part description. Some parts will require color or voltage information.

If U-Line requires the return of original parts, we will inform you when the parts order is taken. This requirement will be noted on your packing list. A prepaid shipping label will be emailed to you. Please enclose a copy of the parts packing list and be sure the model and serial numbers are legible on the paperwork. Tag the part with the reported defect.

Customers and non-authorized servicers may order non-warranty parts at [www.u-line.com](http://www.u-line.com). Authorized servicers with a servicer login may order non-warranty parts at [www.u-lineservice.com](http://www.u-lineservice.com).

## R-600A Specifications

For R-600a refrigerant service tips and more videos, go to: [www.u-line.com/videos](http://www.u-line.com/videos).



**Flammability warnings for a pure-iso-butane refrigerant.**



**Gloves and Eye Protection must be used.**



**R-600a is considered non-toxic, but is flammable when mixed with air.**

**Keep a dry powder type fire extinguisher in the work area.**



**R-600a is heavier than air, do not allow any leakage/migration to low areas such as basements and stairs.**

**Never use a torch on a fully charged refrigeration system.**

**Never substitute U-Line OEM replacement parts or methods of construction.**

**R-600a must be stored and transported in approved containers.**

**⚠ WARNING**

**Only skilled and well trained service technicians permitted to service R-600a equipped products.**

**All tools and equipment must be approved for use with R-600a refrigerant.**

**Local, state and federal laws, standards must be observed along with proper certification and licensing.**

**Ventilation is required during servicing.**

**No conversions to R-600a from any other refrigerants. OEM R-600a equipped unit only.**

**Service area must be free of ignition sources.**

**No smoking is allowed in the service area.**

**All replacement electrical components must be OEM and installed properly (sealed and covered).**

**If the evaporator is cold prior to service, it must be thawed prior to service.**

**When using a vacuum pump, start pump before opening refrigeration system.**

**Vacuum pump and recovery equipment should be at least 10 feet from the work area.**

**It is recommended that a simple LPG gas detector is on site during service.**

**Ensure that all R-600a is removed from the system prior to brazing any part of the sealed system.**

**Only a clean, dry leak free system should be charged with R-600a.**

**R-600A SPECIFICATIONS/LABELING**

R-600a equipped products are labeled (both the unit and the compressor).

R-600a is colorless and odorless.

R-600a is considered non-toxic, but is flammable when mixed with air.

Do not remove or alter any R-600a labeling on the product.

Use only a refrigerant grade R-600a from a properly labeled container.

**RECOVERING/RECLAIMING R-600A**

(R-600a has been exempted from recovery/reclaiming requirements by the US EPA)

Recovery/Reclaiming equipment must be approved for use with R-600a.

Ensure the evaporator is at room temperature prior to recovery/reclaiming R-600a.

Use a common piercing pliers or piercing valve to remove R-600a from the compressor process tube. (Note: Piercing devices must not be left on the system and must be replaced with a Schrader type valve.)

Evacuate/reclaim via the piecing pliers to ensure the system is empty of R-600a before any system work is performed.



The recovery cylinder must be evacuated (no air inside) prior to accepting R-600a.

The recovery cylinder must not be filled more than 45% safe fill level and refrigerants must not be mixed.

The recovery cylinder must be clearly marked with R-600a and Flammable Warning labels.

Ensure proper ventilation during recovery/reclaiming of R-600a.

Start vacuum pump/recovery pump prior to piercing the compressor process tube.

Follow recovery/reclaim OEM instructions for the specific equipment used.

## SYSTEM REPAIR

Ensure no residual R-600a refrigerant is left within the system prior to repair (simple venting is not sufficient).

Evacuate and charge with dry nitrogen for leak checks.

Repair leaks or replace system parts as required.

When re-brazing, the system must be purged with dry nitrogen and at least one access point open to the atmosphere.

When re-brazing, proper ventilation is required along with constant monitoring for the presence of R600a refrigerant.

The filter dryer must be replaced any time the sealed system is serviced.

No system should be open to the atmosphere for longer than 15 minutes to avoid moisture migration into the system components.

## LEAK DETECTION

After removal of the R-600a, the unit can be charged with dry nitrogen or helium.

Electronic leak detection or soap solution can be used to check for nitrogen/helium leaks.



Never use a halide torch or lighted match to check the system for leaks at any time.

The high side of the refrigeration system (compressor discharge to outlet of drier) must be leak tested with the compressor running.

The low side of the refrigeration system (evaporator, compressor and suction line) must be leak tested with the compressor off (equalized pressure).

## **RECHARGING**

No air is ever to be allowed inside the refrigeration system (R-600a refrigerant or dry nitrogen only).

Never use a torch on a fully charged refrigeration system.

Install a Schrader Type access port on the compressor process stub.



Evacuate the system to 100 microns prior to charging.

Weigh in the R-600a charge using a refrigerant scale. (run compressor an extra two minutes to clear the charging hoses).

Seal the Schrader Type access port, a proper cap and seal must be used to close the system.



## **SUMMARY**

Safely handling R-600a requires proper procedures and training.

R-600a approved service tools must be used.

R-600a labeling must not be removed or altered.

Proper ventilation during service is required.

Never apply a torch to a charged R-600a refrigeration system.

Use OEM replacement service parts and do not alter the construction of the unit.



## System Diagnosis Guide

### REGRIGERATION SYSTEM DIAGNOSIS GUIDE

<b>System Condition</b>	<b>Suction Pressure</b>	<b>Suction Line</b>	<b>Compressor Discharge</b>	<b>Condenser</b>	<b>Capillary Tube</b>	<b>Evaporator</b>	<b>Wattage</b>
<b>Normal</b>	Normal	Slightly below room temperature	Very hot	Very hot	Warm	Cold	Normal
<b>Overcharge</b>	Higher than normal	Very cold may frost heavily	Slightly warm to hot	Hot to warm	Cool	Cold	Higher than normal
<b>Undercharge</b>	Lower than normal	Warm-near room temperature	Hot	Warm	Warm	Extremely cold near inlet - Outlet below room temperature	Lower than normal
<b>Partial Restriction</b>	Somewhat lower than normal vacuum	Warm-near room temperature	Very hot	Top passes warm - Lower passes cool (near room temperature) due to liquid	Room temperature (cool) or colder	Extremely cold near inlet - Outlet below room temperature backing up	Lower than normal
<b>Complete Restriction</b>	In deep vacuum	Room temperature (cool)	Room temperature (cool)	Room temperature (cool)	Room temperature (cool)	No refrigeration	Lower than normal
<b>No Gas</b>	0 PSIG to 25"	Room temperature (cool)	Cool to hot	Room temperature (cool)	Room temperature (cool)	No refrigeration	Lower than normal

## Compressor Specifications

**⚠ DANGER**

**Electrocution can cause death or serious injury. Burns from hot or cold surfaces can cause serious injury. Take precautions when servicing this unit.**

**Disconnect the power source.**

**Do not stand in standing water when working around electrical appliances.**

**Make sure the surfaces you touch are not hot or frozen.**

**Do not touch a bare circuit board unless you are wearing an anti-static wrist strap that is grounded to an electrical ground or grounded water pipe.**

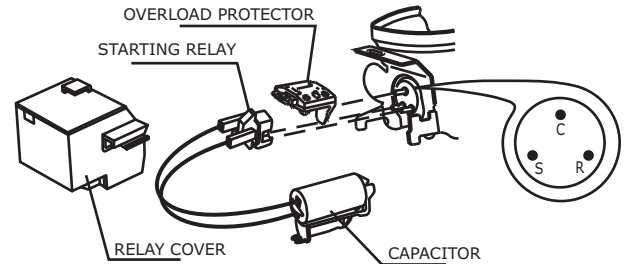
**Handle circuit boards carefully and avoid touching components.**

To measure the start winding resistance, measure across the C and S pins.

To measure the run winding resistance, measure across the C and R pins.

Also check S to R and you should get the sum of the run and start windings.

To ensure the windings are not shorted, check the S and R to ground.



ULLIN\_0368\_A

	<b>EMX20CLC</b>
Refrigerant	R600a
Voltage	115 - 127 VAC
Frequency	60 Hz
Run Cap	12µF/165 VAC
Start Winding	6.7 Ohm at 77°F
Run Winding	12.6 Ohm at 77°F
LRA	3.7 A
FLA	0.5 A
Starting Device	8EA14C
Overload	4TM142RFBYY-53

\* All resistance readings are ±10%

## Troubleshooting - Extended

**CAUTION**

**Never attempt to repair or perform maintenance on the unit until the main electrical power has been disconnected from the unit.**

### SPECIFIC ERRORS AND ISSUES

The advanced diagnostic capabilities of the electronic controls utilized on the 1, 3, and 5 Class units allow for easy and thorough troubleshooting.

Navigation of the control is the key and is explained in the CONTROL OPERATION section of the manual, along with control button layout, control function descriptions, a service mode menu and service menu selection explanations.

Verification of temperature and thermistor performance can be identified by directly viewing thermistor readings in the service mode.

Included in this section are some diagnostic tips and of course, if additional help is required, please contact the U-Line Corp, "Customer Care Facility" at +1.800.779.2547 for assistance.

### NORMAL OPERATING SOUNDS

All models incorporate rigid foam insulated cabinets to provide high thermal efficiency and maximum sound reduction for its internal working components. Despite this technology, your model may make sounds that are unfamiliar.

Normal operating sounds may be more noticeable because of the unit's environment. Hard surfaces such as cabinets, wood, vinyl or tiled floors and paneled walls have a tendency to reflect normal appliance operating noises.

Listed below are common refrigeration components with a brief description of the normal sounds they make. NOTE: Your product may not contain all the components listed.

- Compressor: The compressor makes a hum or pulsing sound that may be heard when it operates.
- Evaporator: Refrigerant flowing through an evaporator may sound like boiling liquid.
- Condenser Fan: Air moving through a condenser may be heard.
- Automatic Defrost Drain Pan: Water may be heard dripping or running into the drain pan when the unit is in the defrost cycle.

Solenoid Valves: An occasional clicking sound may be heard as solenoid valves are operated.

## TROUBLESHOOTING GUIDE

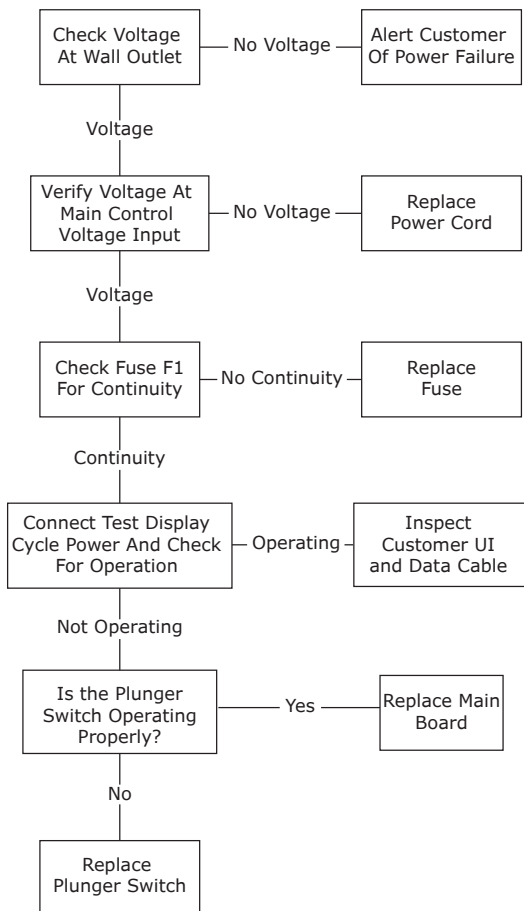
Concern	Potential Causes	Action
Not Cooling	Compressor overheating	Verify proper air flow through condenser. Is condenser clean? Confirm condenser fan operation.
	Compressor not operating	Test overload and relay, replace as needed.
	Compressor operating - no cooling	Refer to System Diagnosis Guide.
Frozen Product	Control set too cold	Adjust Set Point Temp accordingly.
	Thermistor failure	Check Error Log in Service Mode, OHM thermistor.
Frost Buildup Inside Unit	Door Ajar or Restricted from Closing	Check door clearance to adjoining cabinetry. Check distribution of product in unit.
	Thermistor failure	OHM thermistor
Display Not Working	Display unplugged	Verify that both ends of the display wiring are firmly connected.
	Display wiring broken or damaged	Perform continuity test of wiring and replace as needed.
Interior Lights Not Working	Door switch misaligned or defective	Check the function of reed switch and door magnet adjustment.
Noisy	Refrigeration tubing touching cabinet	Carefully reposition tubing.
	Fan blade obstruction (wiring, foam insulation, packaging material)	Remove obstruction.

## MAIN CONTROL

The main control board is very robust and is rarely the cause of system issues. It is important to fully diagnose the board for any suspected failures before attempting to remove the board for replacement or service. Follow the guidelines below to fully test and diagnose the main control.

### Power Fault

If the unit does not (or seems to not) power on, follow the flow chart below to help diagnose the issue. Before beginning it is important to first verify the unit is not simply set to sabbath mode.

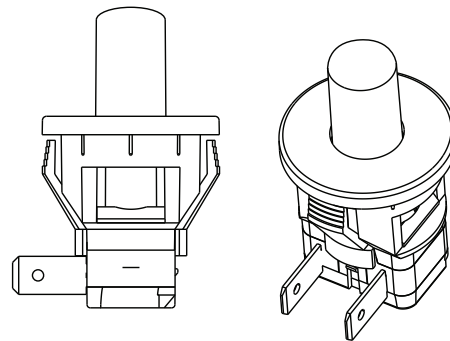


## ⚠ CAUTION

**Precautions must be taken while working with live electrical equipment. Be sure to follow proper safety procedures while performing tests on live systems.**

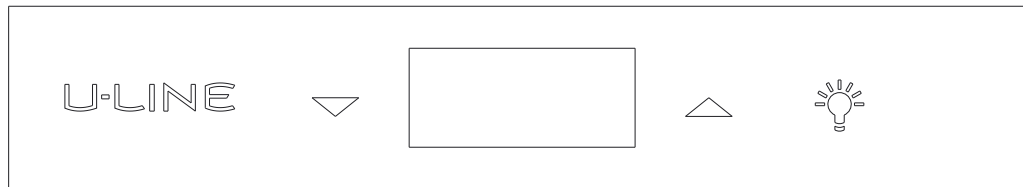
### PLUNGER SWITCH

A plunger switch is used to monitor door state. When the door is closed it comes into contact with the plunger which closes a circuit which turns the light and display off. When the door is open the plunger moves outward and opens the circuit. If the door is left open for longer than 5 minutes the switch will trigger an error code and set an audible warning.



## Control Operation-Service

### UI BUTTON LAYOUT



#### 1. Up Button

- Increases temperature
- Navigates through service menu
- LED activated with button activation












#### 2. Down Button

- Decreases temperature
- Navigates through service menu
- LED activated with button activation

#### 3. Light Button

- Activates light for 3 hours on select models
- Used to select items in service menu
- LED activated with button activation

### CONTROL FUNCTION GUIDE

FUNCTION	COMMAND	NOTES
Defrost Duration	Enter menu by pressing  for more than 5 seconds. Use  or  to increase/reduce defrost duration. Press  to select.	Display shows "df" (defrosting). Display shows "00-99" (minutes of current defrost duration setting).
Defrost Period	Press  once again. Use  or  to increase/reduce defrost period. Press  again.	Display shows "CU" (accumulation). Display shows "00-99" (minutes of current defrost duration setting).
Set Offset Temperature	Use  or  to increase/reduce temperature.	After 12 hours, factory default is restored; light will turn on when door is open.
Exit Menu	Press  and release	

## Defrost

Outdoor units defrost every 12 hours of compressor runtime for 45 minutes. If you have verified that the unit does not have an ambient air leak, utilize the **Control Operation - Service** section and adjust unit to defrost every 9 hours for 60 minutes

## Remove Fan and Cover

### CONVECTION COOLING

This unit is equipped with an advanced convection cooling system. Convection cooling stabilizes cabinet temperature, cools product faster and increases energy efficiency.

### Evaporator Fan

The evaporator fan is responsible for circulating warm air from the refrigeration zone, past the evaporator and back into the refrigerated zone.

The evaporator fan is factory set to have a 1 minute delay at the beginning of a cooling cycle. This delay gives the evaporator time to cool properly before warm air is passed over it. The fan will continue to run for an additional 2 minutes at the end of a cooling cycle. Fan delay times can be modified through the service menu.

Evaporator fan operation is also determined by door switch state. If the door switch circuit opens, the fan will stop. When the door switch circuit is closed the fan will either continue running with the cooling cycle, or if not currently cooling, the fan will run for 1 minute to circulate air and clear any condensation that may have appeared on glass doors and shelves.

*Note:* If the unit is set to sabbath mode, the evaporator fan will no longer respond to the state of the door switch.

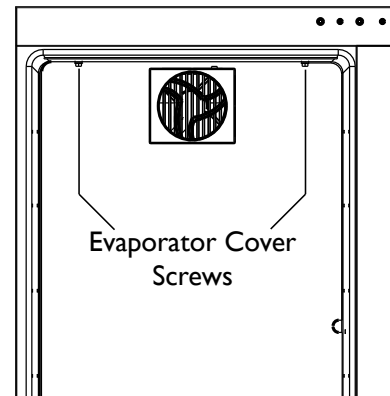
In order to operate efficiently, the evaporator fan blade and vents should be unobstructed and free of any dust buildup.

### Evaporator Fan Replacement

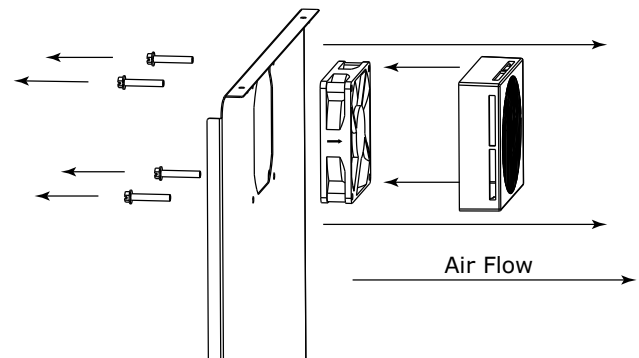
Should the evaporator fan need to be replaced follow the steps below.

1. Remove any product from the unit.
2. Remove unit from cabinetry to access rear.
3. Disconnect power to the unit.
4. Remove back panel from unit.
5. Disconnect fan electrical connection at rear of unit.

6. Remove insulating foam from refrigerant line pass-through hole as needed to gain clearance for fan plug.
7. Remove internal shelving.
8. Remove rear shelf clips, fronts can remain.
9. Remove thermistor cover.
10. Remove two evaporator cover screws from top of evaporator plate.



11. Grasp evaporator cover, pull forward and up as bottom of cover is installed behind the front edge of the drain trough.
12. While pulling the evaporator cover clear of the unit, it may be necessary to use your free hand to manipulate the fan plug end through the pass-through hole.
13. Remove the 4 screws mounting the fan shroud to the evaporator plate.





14. Remove and replace fan. Take special care to properly route fan wire.

## **NOTICE**

**Fan must be oriented to pull air in through lower evaporator cover vents and push air out at fan mounting location.**

15. Installation is the reverse of removal.
16. Care must be taken to assure the bottom of the evaporator cover is reinstalled behind the front edge of the train trough.
17. Use sealant gum to seal any openings at rear of unit before replacing rear cover.
18. Reinstall unit taking care to level, space and secure as found.

# U-Line Corporation (U-Line) Limited Warranty

## One Year Limited Warranty

For one year from the date of original purchase, this warranty covers all parts and labor to repair or replace any part of the product that proves to be defective in materials or workmanship. For products installed and used for normal residential use, material cosmetic defects are included in this warranty, with coverage limited to 60 days from the date of original purchase. All service provided by U-Line under the above warranty must be performed by a U-Line factory authorized servicer, unless otherwise specified by U-Line. Service provided during normal business hours.

## Two Year Limited Warranty (5 Class Product)

For two years from the date of original purchase, this warranty covers all parts and labor to repair or replace any part of the product that proves to be defective in materials or workmanship. For products installed and used for normal residential use, material cosmetic defects are included in this warranty, with coverage limited to 60 days from the date of original purchase. All service provided by U-Line under the above warranty must be performed by a U-Line factory authorized servicer, unless otherwise specified by U-Line. Service provided during normal business hours.

## Available Second & Third Year Limited Warranty

In addition to the standard one and two year warranties outlined above, U-Line offers a one year extension of the warranties from the date of purchase, free of charge. To take advantage of this extension, you must register your product with U-Line within 60 days from the date of purchase at [u-line.com](http://u-line.com) and provide proof of purchase.

## Five Year Sealed System Limited Warranty

For five years from the date of original purchase, U-Line will repair or replace the following parts, labor not included, that prove to be defective in materials or workmanship: compressor, condenser, evaporator, drier, and all connecting tubing. All service provided by U-Line under the above warranty must be performed by a U-Line factory authorized servicer, unless otherwise specified by U-Line. Service provided during normal business hours.

## Terms

These warranties apply only to products installed in any one of the fifty states of the United States, the District of Columbia, or the ten provinces of Canada. The warranties do not cover any parts or labor to correct any defect caused by negligence, accident or improper use, maintenance, installation, service, repair, acts of God, fire, flood or other natural disasters. The product must be installed, operated, and maintained in accordance with your product's User Guide.

The remedies described above for each warranty are the only ones that U-Line will provide, either under these warranties or under any warranty arising by operation of law. U-Line will not be responsible for any consequential or incidental damages arising from the breach of these warranties or any other warranty, whether express, implied, or statutory. Some states do not allow the exclusion or limitation of incidental or consequential damages, so the above limitation or exclusion may not apply to you. These warranties give you specific legal rights, and you may also have other rights which vary from state to state.

Any warranty that may be implied in connection with your purchase or use of the product, including any warranty of *merchantability* or any warranty *fit for a particular purpose* is limited to the duration of these warranties, and only extends to five years in duration for the parts described in the section related to the five year limited warranty above. Some states do not allow limitations on how long an implied warranty lasts, so the above limitations may not apply to you.

- The warranties only apply to the original purchaser and are non-transferable.
- The second, third, and five year warranties cover products installed and used for normal residential or designated marine use only.
- The warranties apply to units operated outside only if designed for outdoor use by model and serial number.
- U-Line Commercial products are covered by the one year and 5 year limited warranties and are not eligible for the second and third year limited warranties.
- Replacement water filters, light bulbs, and other consumable parts are not covered by these warranties.
- The start of U-Line's obligation is limited to four years after the shipment date from U-Line.
- In-home instruction on how to use your product is not covered by these warranties.
- Food, beverage, and medicine loss are not covered by these warranties.
- If the product is located in an area where U-Line factory authorized service is not available, you may be responsible for a trip charge or you may be required to bring the product to a U-Line factory authorized service location at your own cost and expense.
- Units purchased after use as floor displays, and/or certified reconditioned units, are covered by the limited one year warranty only and no coverage is provided for cosmetic defects.
- Signal issues related to Wi-Fi connectivity are not covered by these warranties.

For parts and service assistance, or to find U-Line factory authorized service near you, contact U-Line:  
8900 N. 55<sup>th</sup> Street, Milwaukee, WI 53223 • [u-line.com](http://u-line.com) • [onlineservice@u-line.com](mailto:onlineservice@u-line.com) • +1.800.779.2547