

SINCE 1902

AX-M12

12 Quart Mixer

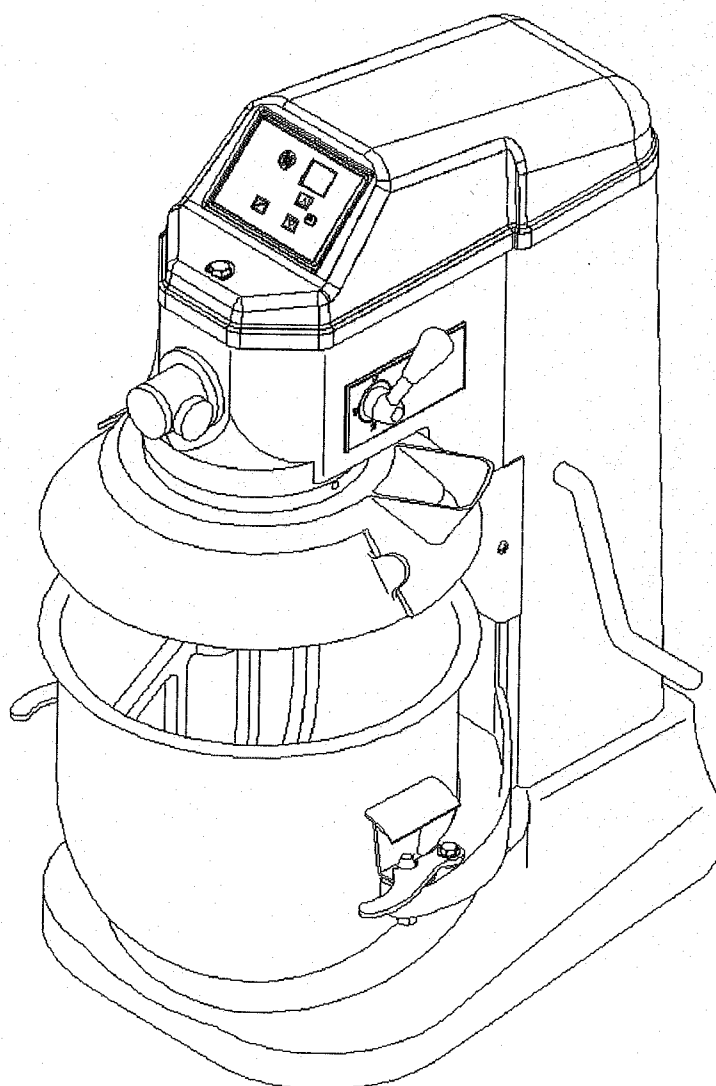

Installation, Operation and Care of 12 QT MIXER

+ SAVE THESE INSTRUCTIONS +

GENERAL

This Mixer is an advanced design, highly reliable professional food processing tool, and is ideal for mixing all types of dough, as well as eggs, cream, mayonnaise, etc.

This model Mixers are equipped with powerful 1/2 HP motors and strong gear drive design. The gears are made of heat-treated alloy steel and a hardness steel worm wheel. There are 3 speeds and various style attachments, which can be selected to obtain the best using food, are made of alloy aluminum or they're with hygiene standard. **A stainless steel safety guard is standard on model 72-AX12A.**

If your operation and maintenance are correct, then it will give you years of service, and obtain the best using result.

INSTALLATION

UNPACKING

Immediately after unpacking the mixer, check it for possible shipping damage. If this machine is found to be damaged after unpacking, save the packaging material and contact the carrier immediately. Prior to installation, test the electrical service to assure it agree with the specifications on the machine data plate located on the backside of the pedestal.

LOCATION

Place the mixer in its operating location. Bench should be placed on a sturdy level surface. There should be adequate space around the mixer for the user to operate the control and install and remove bowls.

Holes are provided in the base to permanently secure the mixer, although this not necessary in normal installations. Floor models must be leveled front-back and side-to-side by sliding shims under the legs as required.

ELECTRICAL CONNECTIONS (Cord Connected Mixers)

WARNING: THIS SUPPLY CORD ON THIS MACHINE IS PROVIDED WITH A THREE-PRONG GROUNDING PLUG. IT IS IMPERATIVE THAT THE OUTLET TO WHICH THIS PLUG IS CONNECTED BE PROPERLY GROUNDED. IF THE RECEPTACLE IS NOT THE PROPER GROUNDING TYPE, AN ELECTRICIAN SHOULD BE CONTACTED.

A 3 PHASE MIXER SHOULD CHECK MIXING ROTATION WHEN ELECTRICAL CONNECTED.

INSTALLATION DIAGRAM (mm)

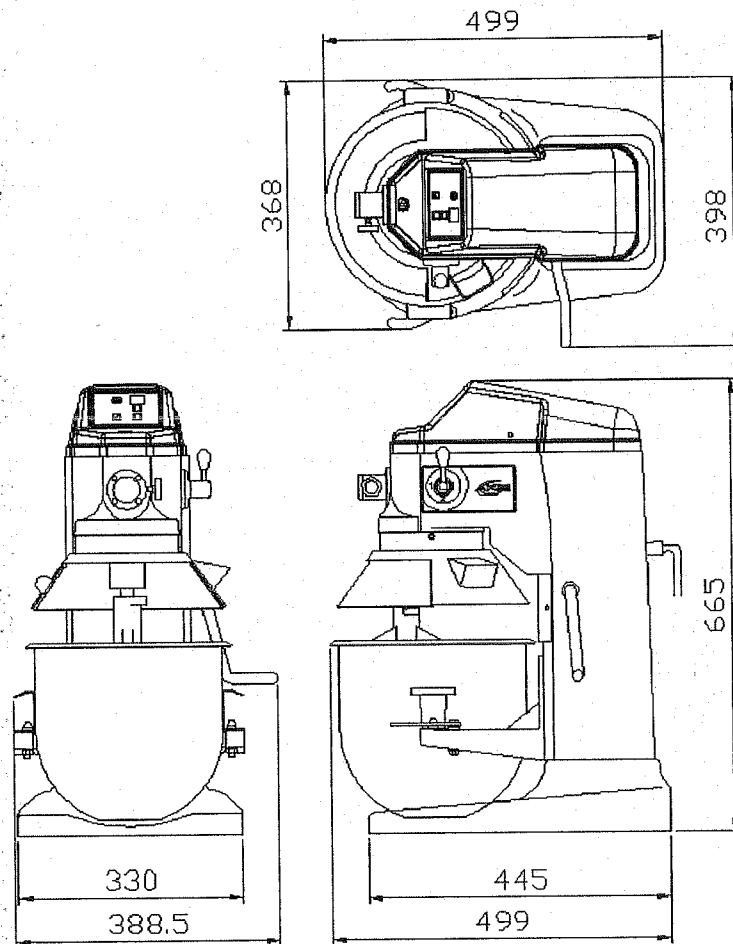

Model No.	Bowl Capacity	Motor for Agitator	Agitator speeds (R.P.M.)	ELECTRICAL
AX-M12	12 Qt.	0.5 HP	515/262/146	110V/60HZ/1 PH

OPERATION

WARNING: MOVING BEATER IN BOWL. KEEP HAND, CLOTHING, AND UTENSILS OUT WHILE IN OPERATION.

All models are furnished with an ON-OFF switch (figure 1-11), which controls power to the mixer.

The GEAR SHIFT LEVER (figure 1-3) is used to change speeds. Always stop the mixer before changing speeds. To change speeds, turn the switch OFF, move the gearshift lever to the desired speed, and turn the switch back ON.

- Speed 1 (low) - This speed is for heavy mixtures such as bread dough, heavy batters, and potatoes.
- Speed 2 (medium) - This speed is for light dough, which must rise quickly, heavy batters, and some whipping operations.
- Speed 3 (high) - This speed is fast speed for light work such as whipping cream, beating eggs, and mixing thin batters.

Figure 1

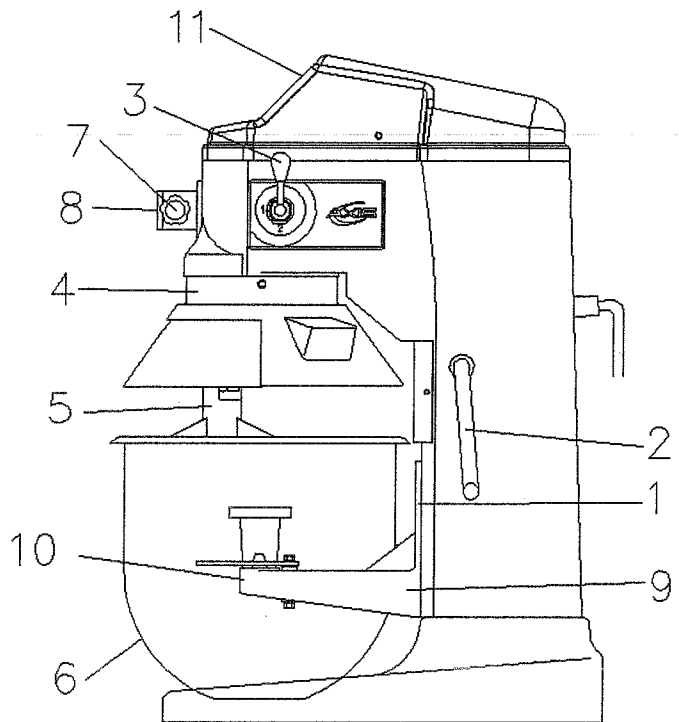

AGITATOR

To install an agitator (figure 1-5), the bowl (Figure 1-6) must be installed and fully lowered. Place the agitator in the bowl, push it up on the agitator shaft, and turn it clockwise to seat the shaft pin in the slot of the agitator shank.

DOUGH ARM:

Frequently used for heavy bread dough, and preferable to be used at low speed.

The moisture content of heavy dough is critical when selecting proper mixing speed. You should never use 2nd speed when mixing heavy dough with an Absorption Ratio (AR) of 50% or less.

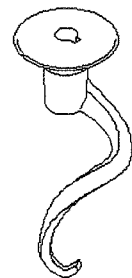

BEATER:

Commonly used for thin batters, cake and mashing potatoes, like stuffing and preferable to be used at middle speed.

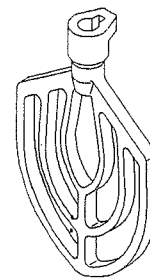

WIRE WHIP:

Best for whipping cream and beating eggs and preferable to be used at high speed.

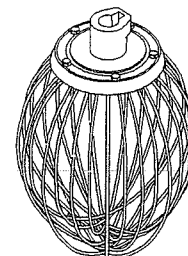

BOWL

New mixer's bowl (Figure 1-6) and agitators (beaters, whip, and dough arms) should be thoroughly washed with hot water and mild soap solution, rinsed with either a mild soda or vinegar solution, and thoroughly rinsed with clean water BEFORE being put into service. This cleaning procedure should also be followed for bowls and agitators before whipping egg whites with or whole eggs.

CONTROL PANEL (Figure 1-11)

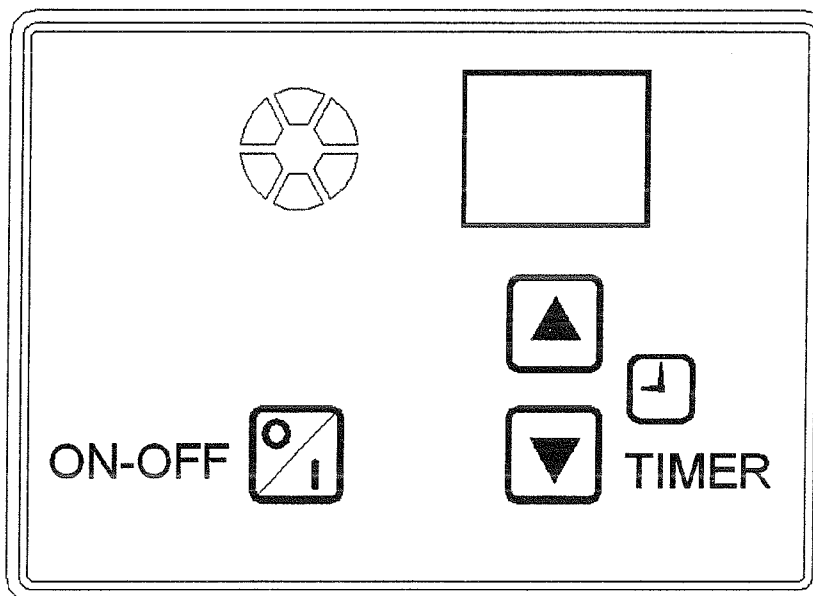

MAINTENANCE

NOTE: ALL MAINTENANCE WORK SHOULD BE DONE ONLY AFTER UNIT HAS BEEN DISCONNECTED FROM ELECTRICAL POWER AND GROUNDING.

Never use a metal or stiff brush to clean the mixer. Never clean the mixer with a water hose or any fluid pressure.

The mixer should be thoroughly cleaned daily.

Bowls and agitators should be removed from the mixer and cleaned in a sink.

The transmission case and planetary mechanism should be inspected weekly for leaks, damage, etc. Should it become necessary to repack the ball bearings, an authorized service technician or the manufacturer should be contacted. Use of unproved grease or lubricants may lead to damage and void the unit's warranty.

The **bowl lift slidways** (Figure 1-1) should be lubricated semi-annually, or more often under heavy usage. Disconnect the unit from the power supply before removing the top housing or apron. The **drip cup** (Figure 1-4) or **safety guard** should be inspected periodically for moisture or lubricant dripping. Remove the cup and wipe it with a soft cloth.

CLEANING

The mixer should be thoroughly cleaned daily.

Bowls and agitators should be removed from the mixer and cleaned in a sink.

DO NOT use a hose to clean the mixer - it should be washed with a clean damp cloth.

The drip cup (Figure 1-4) should be removed periodically and wiped clean. A large flat blade screwdriver may be used to remove the drip cup

WIRING DIAGRAM

