

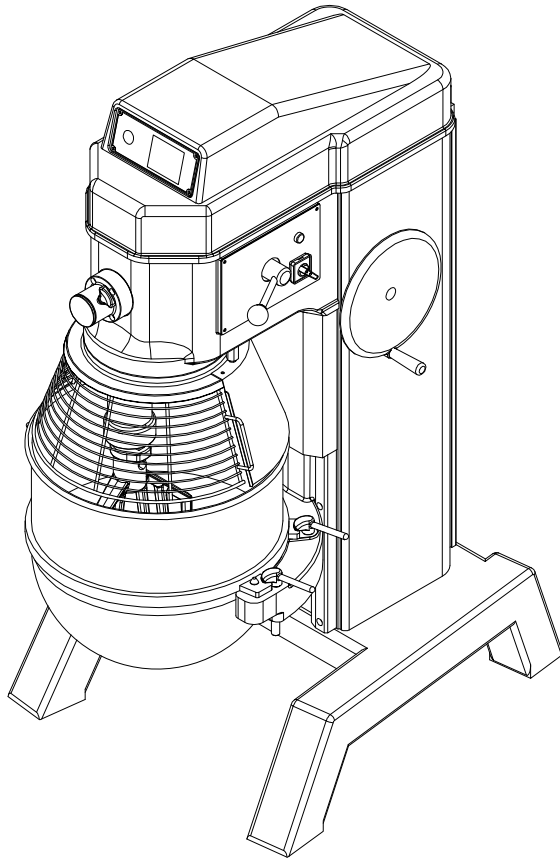

**AX-M60P**  
**60 QUART PIZZA MIXER**



Model	Capacity	Motor	Amps	Speeds	Electrical
AX-M60P	60 Quart	2 Speeds	18	72 / 118	220v / 60hz / 1ph
			6.2		220v / 60hz / 3ph

# TECHNICAL MANUAL

# INSTALLATION, OPERATION AND CARE OF MODEL AX-M60P

## GENERAL

The AX-M60 planetary mixer is an advance design, highly reliable professional food processing tool, and is ideal for mixing all types of dough as well as eggs, cream, mayonnaise, etc.

There are 2 speeds and various style attachments which can be selected. They are made of alloy aluminum to meet with hygiene standard.

This model mixers is equipped with powerful 3 HP motors and strong gear drive design. The gears are made of heat-treated alloy steel and a harnessed steel worm wheel.

If your operation and maintenance are correct, then it will give you years of service, and obtain the best using result.

## INSTALLATION

### UNPACKING

Immediately before unpacking mixer, check it for possible shipping damage. If you find the packaging material or the machine is damaged before unpacking, contact the carrier within 3 days of delivery. Prior to installation, test the electrical service to assure it agrees with the specifications on the machine data place located on the backside of the pedestal.

### LOCATION

Place the Mixer in a convenient location, and allow working space on the hand-wheel or power bowl lift switch side. All maintenance can be handled from this side, the top and the front. Set the mixer level and use shims if the floor is uneven, the machined edge on the top of the transmission case makes an excellent surface for leveling.

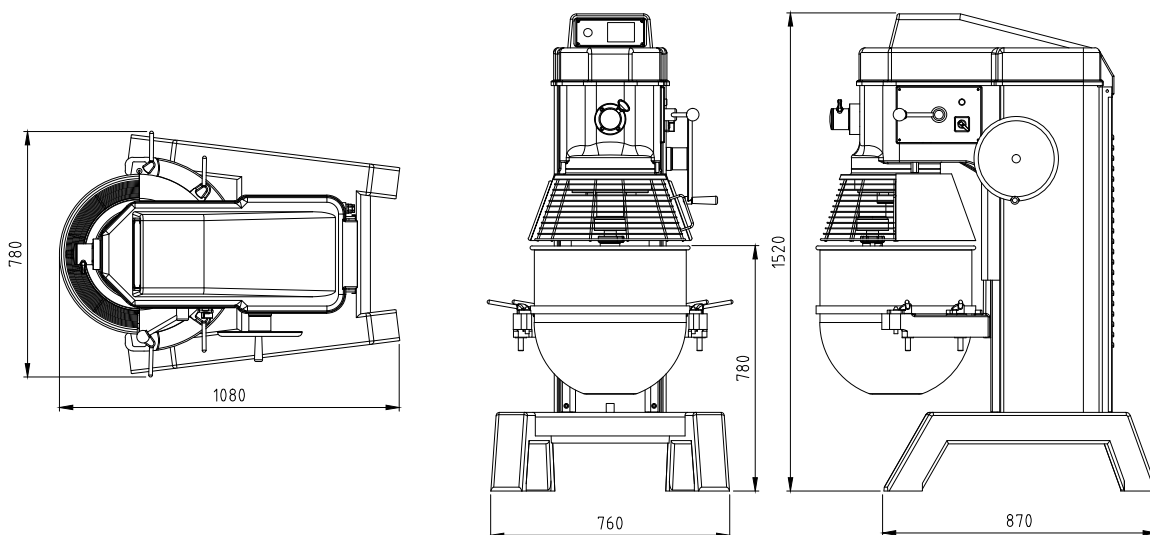

## Electrical Connections (Cord Connected Mixers)

- Before making the electrical connections, read the specifications on the nameplate to make sure that they agree with those of your electric service.
- Electrical connections should be made by qualified technician or electrician, who will observe all applicable Safety Codes and the National Electrical Code.
- Be sure the planetary runs in the direction shown by the arrow in the planetary head. Reverse direction is forbidden.
- To start motor, push ON button. The speed selector handle must be at one of the numbers indicating a speed, not at an intermediate position.

**On a 3 Phase Mixer, the installer must check the mixing rotation of the planetary when the electrical is connected.**

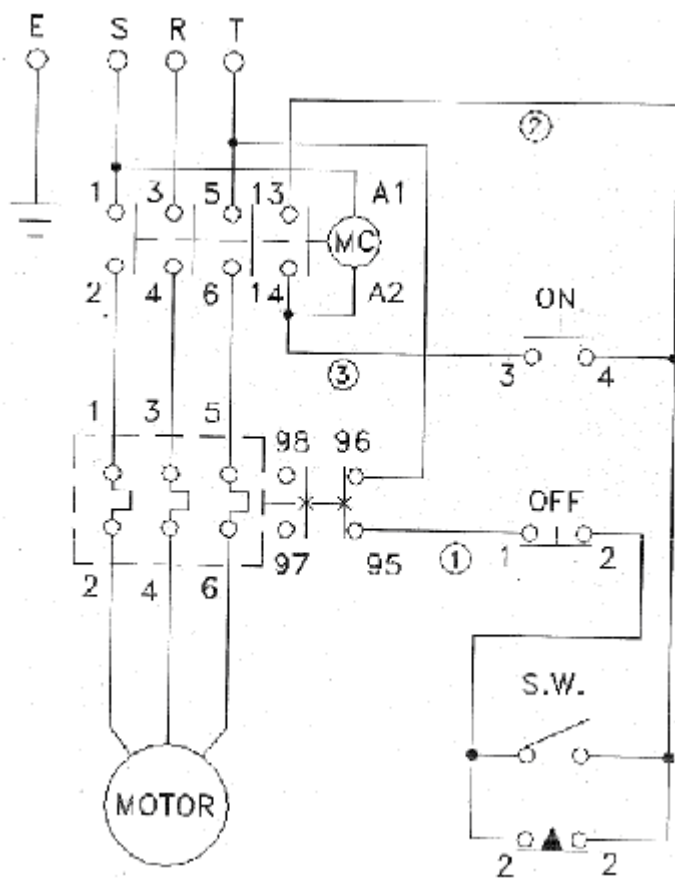
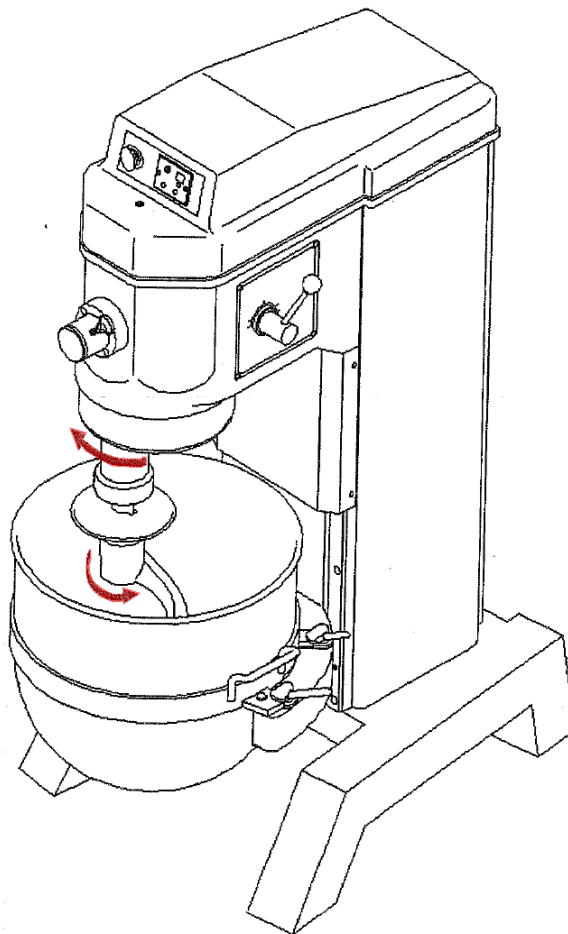

Revision Date: AUT- 05, 2015  
 AXM60-P

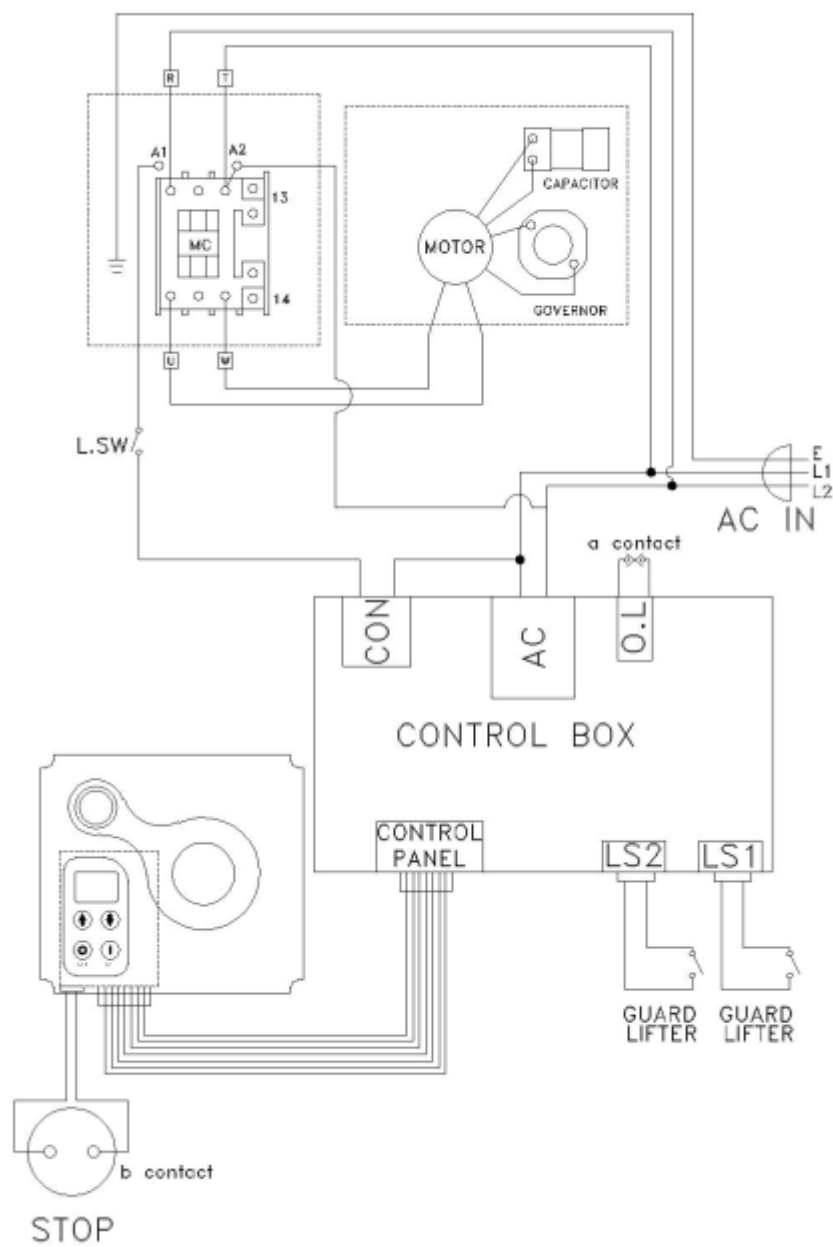

## OPERATION

**WARNING: MOVING PARTS, BEATER OR HOOK IN BOWL; KEEP HANDS, CLOTHING, AND UTENSILS OUT WHILE IN OPERATION.**

All models are furnished with two button-switches, which control power to the mixer.

The GEAR SHIFT LEVER (No.3) is used to change speed. Always stop the mixer before changing speeds. To change speeds, turn the switch OFF, move the gearshift lever to the desired speed, and turn the switch back ON.

- Speed 1 (low) – This speed is for heavy mixtures such as bread dough, heavy batters, and potatoes.
- Speed 2 (medium) – This speed is for light dough which must rise quickly, heavy batters, and some whipping operations.

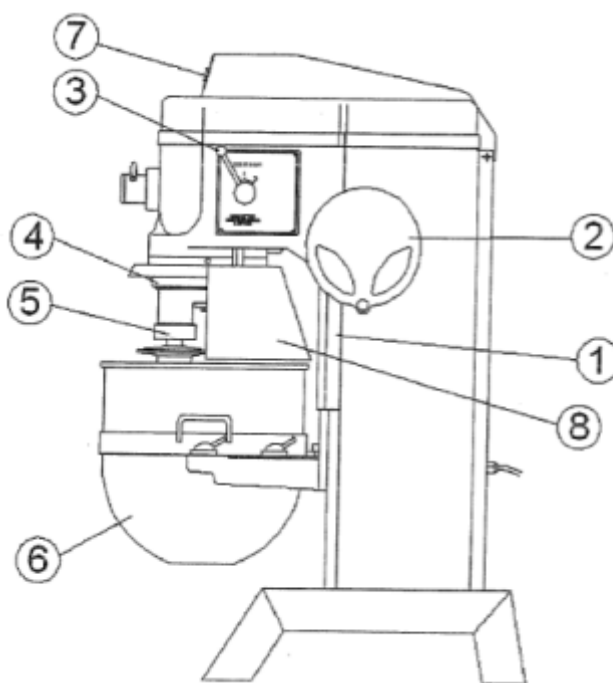

1. APRON
2. BOWL LIFT HANDLE
3. GEAR SHIFT LEVER
4. DRIP CUP
5. AGITATOR
6. BOWL
7. CONTROL PANEL
8. SAFETY GUARD

## DOUGH HOOK:

To install the dough hook (No 5), the bowl must be installed and fully lowered. Place the hook in the bowl, push it up on agitator shaft, and turn it clockwise to seat the shaft pin in the slot of the agitator shank.

It is frequently used for heavy bread dough, and preferable to be use at low speed.

**The moisture content of heavy dough is a critical when selecting proper mixing speed. You should never use 2<sup>nd</sup> speed when mixing heavy dough with an Absorption Ratio (AR) of 50% or less.**

## BOWL – CAPACITY: 60 QUART

New mixers bowls and dough hook should be removed and thoroughly washed with hot water and mild soap solution, rinsed with either a mild soda or vinegar solution, and thoroughly rinsed with clean water BEFORE being put into service. This cleaning procedure should also be done daily or after each use.

The bowl must be installed before the agitator. To install the bowl, fully lower the bowl support. Position the bowl so the alignment bracket on the back of the bowl is in the bowl retainer and the alignment pins on the front of the bowl support fit in the holes on the sides of the bowl.

## ATTACHMENTS

To install an attachment, loosen the thumbscrew on the attachment hub and remove the plug. Insert the attachment into the attachment hub making certain that the square shank of the attachment is in the square driver of the mixer. Secure the attachment by tightening the thumbscrew.

Move the gearshift lever to the desired speed and star the mixer to operate the attachment.

The meat and food chopper attachment should be operated in second or third speed. If material in the cylinder stalls the mixer, stop the mixer at once. DO NOT attempt to restart the mixer in a lower speed – remove the adjusting ring, knife, plate, and worm and clear the obstruction.

CONTROL PANEL

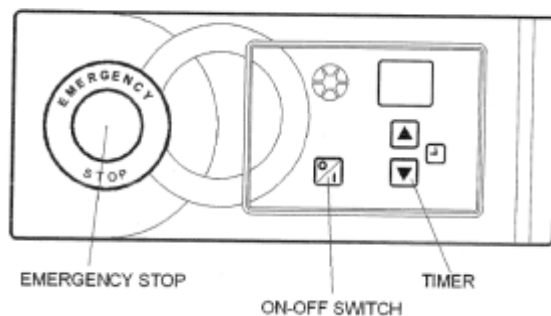

EMERGENCY STOP

ON-OFF SWITCH

TIMER

## MAINTENANCE

**NOTE: All maintenance work should be done only after unit has been disconnected from electrical power and grounding.**

## CLEANING

**Never use a metal or stiff brush to clean mixer. Never clean the mixer with a water hose or any fluid under pressure.**

The mixer should be thoroughly cleaned daily.

Bowl and agitators should be removed from the mixer and cleaned in a sink.

**The transmission case and planetary mechanism** should be inspected weekly for leaks, damage, etc. should it become necessary to repack the ball bearings; an authorized service technician or the manufacturer should be contacted. Use of unapproved grease or lubricants may lead to damage and void the unit's warranty.

The **bowl lift track** should be lubricated semi-annually, or more often under heavy usage. Disconnect the unit from power supply before removing the top housing or apron. The **drip cup** (Fig. 1)? should be inspected periodically for moisture or lubricant dripping. Remove the cup and wipe it with a soft cloth.

DO NOT use a hose to clean the mixer – it should be washed with a clean damp cloth.



## MIXING HEAVY DOUGH

The moisture content of heavy dough is a critical factor when selecting proper mixing speed. You should never use 2<sup>nd</sup> speed when mixing heavy dough with an Absorption Ratio (AR) of 50% or less.

To determine the Absorption Ratio (AR) of a product, divide the water weight by the flour weight.

Example: Calculate the Absorption Ratio of a mixture containing 10 lbs. of flour and 5 lbs. of water.

$$10 \div 5 = 0.50 = 50\% = \text{AR}$$

CAPACITY (QTS. LIQUID)		60 qt.
Egg Whites	Wire Whip	2 qt.
Mashed Potatoes	Flat Beater	40 lbs.
Mayonnaise (Qts. Oil)	Flat Beater	18 qt.
Meringue (Qts. Water)	Wire Whip	1.5 qt.
Waffle/Pancake Batter	Flat Beater	24 qts.
Whipped Cream	Wire Whip	12 qts.
Sheet Cake Batter	Flat Beater	45 lbs.
Cup Cake	Flat Beater	50 dz.
Layer Cake	Flat Beater	70 lbs.
Pound Cake	Flat Beater	55 lbs.
Sugar Cookie	Flat Beater	100 dz.
Bread or Roll Dough (Light/Medium, 60% AR, =)	Dough Hook	80 bs.**
Bread or Roll Dough (Heavy, 55% AR, =)	Dough Hook	60 lbs.**
Pie Dough	Flat Beater	50 lbs.
Thin Pizza Dough (40% AR, =, 5 min.max. mix time)	Dough Hook	40 lbs.**
Medium Pizza Dough (50% AR, =)	Dough Hook	70 lbs.*
Thick Pizza Dough (60% AR, =)	Dough Hook	70 lbs.**
Raised Donut Dough (65% AR)	Dough Hook	30 lbs.*
Whole Wheat Bread Dough (70% AR)	Dough Hook	70 lbs.**
Egg & Sugar for Sponge Cake	Flat Beater	24 lbs.*

\* 1<sup>st</sup> speed \*\* 2<sup>nd</sup> Speed



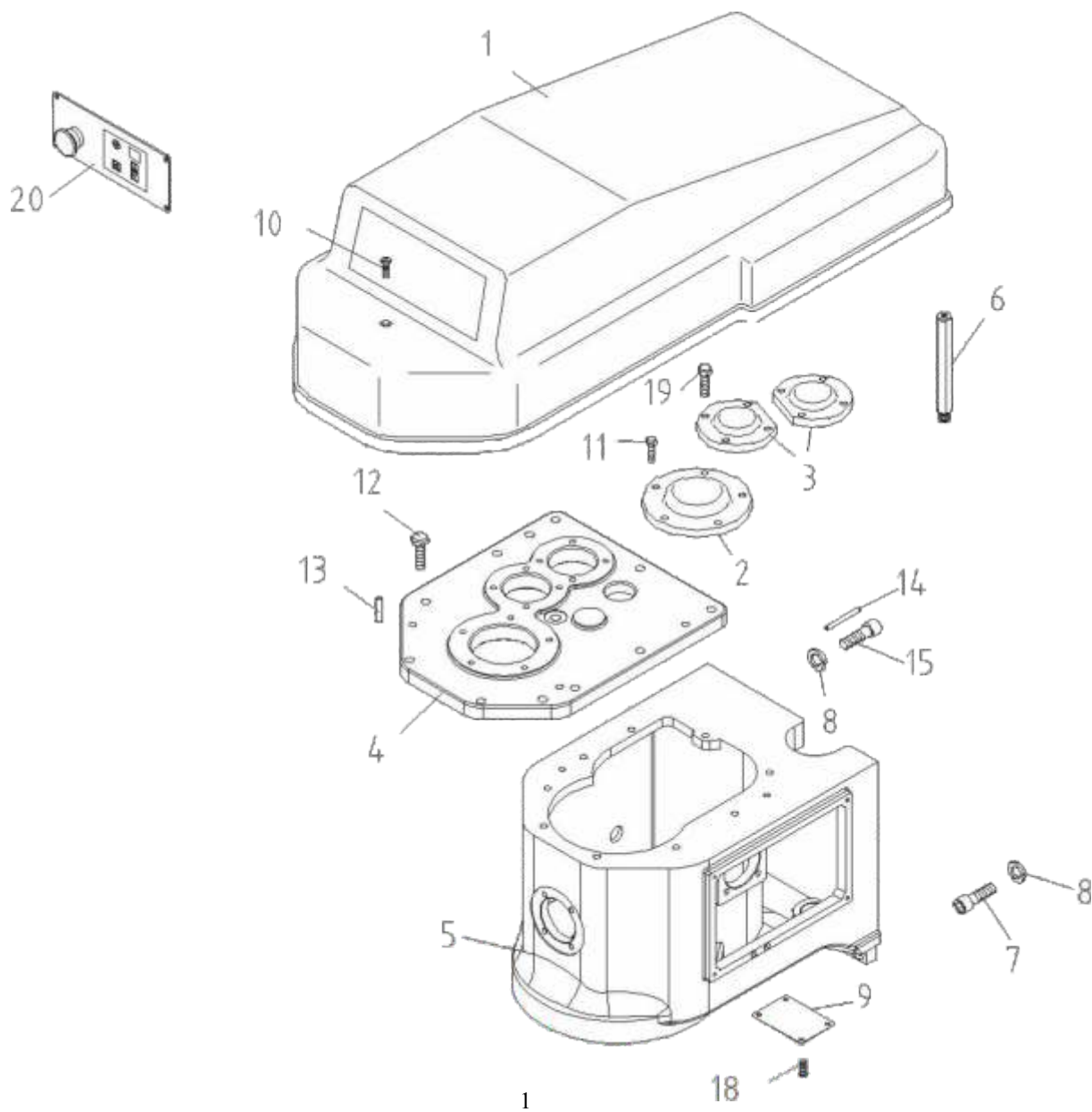
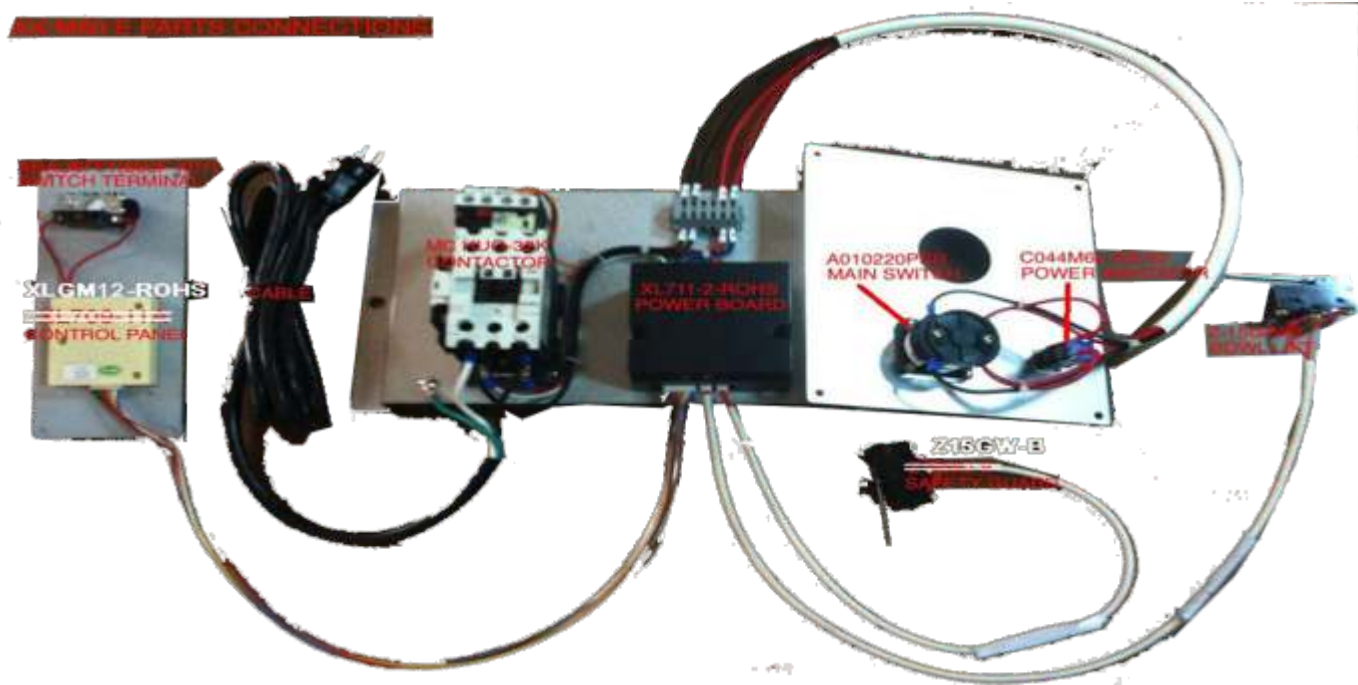

\* = If high gluten flour is used, reduce above dough batch size by





	Description or Name	Parts No.	Qty
1	TOP COVER	11091-01-001A	1
2	RETAINER-MAIN SHAFT	1109S-01-002	1
3	RETAINER-TRANSMISSION SHAFT	1109S-01-003	2
4	GEAR HOUSE COVER	1109S-01-004	1
5	TRANSMISSION CASE	11100B-01-005	1
6	SUPPORT TO TOP COVER	1109S-01-006	1
7	SCREW	S-C-1/2*1-1/4	2
8	SPRING WASHER 1/2"	SW-1/2	6
9	COVER PLATE	BM10-01-006	1
10	SCREW	S+BR-1/4*3/8	1
11	BOLT 5/16*3/4	S-5/16*3/4	5
12	BOLT 3/8*1- 1/4	S-3/8*1-1/4	8
13	SPRING PIN 6*28	SPP-6*28	4
14	SPRING PIN 10*50	SPP-10*50	2
15	SCREW	S-C-1/2*2-1/4	4
16	MACH SCREW 3/16*3/8	S+R3/16*3/8	4
17	OIL COCK	712-050	1
18	MACH SCREW 3/16*3/8	S+R3/16*3/8	4
19	BOLT 5/16*1/2	S-5/16*1/2	8
20	CONTROL PANEL	11091-01-011B	1

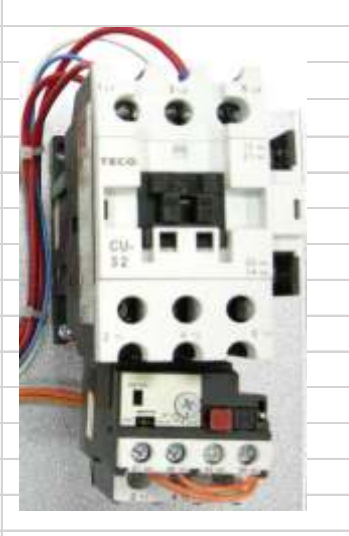

NO.	PICTURE	PARTS NUMBER	PARTS NAME
1		XL709-11A	CONTROL PANEL W/BOX
2		D11001R	STICKER OF PANEL
3		XL711-2-ROHS	Power Board W/ BOX
4		MC HUO-11AK/2HP	CONTACTOR-220V-3 PHASE
5		Z-15GQ-B	LIMIT SWITCH FOR GUARD

6		Z-15GW-B	LIMIT SWITCH FOR BOWL LIFT
7		CABLE-12-3C-NEMA6-15P-UL	POWER CABLE W/PLUG
8		ABESMT44	EMERGENCY STOP (RED BUTTON)
9		ABMS800M	LOCK NUT
10		ABAU8F01 (800F-X01)	SWITCH TERMINAL
11		C044M6L-AS-02	POWER INDICATOR
12		A010220PSR	MAIN SWITCH

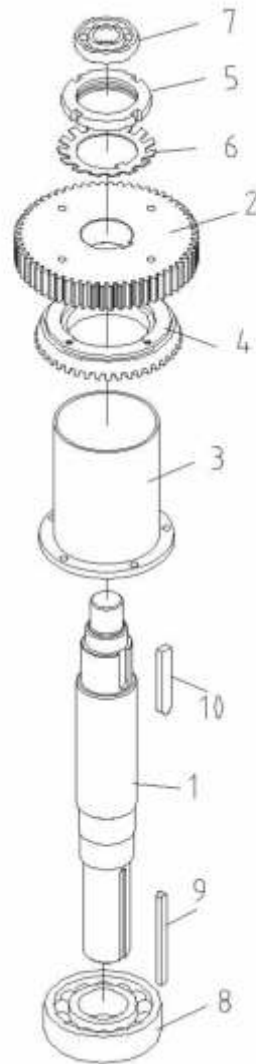

	Description or Name	Part No.	Qty
1	AGITATING SHAFT	11100B-02-001B	1
2	GEAR(OT)	11100B-02-003	1
3	Resistance oil casing	11100B-02-004	1
4	Bevel gear	11193-02-006	1
4	WASHER	11193-02-006A	1
5	LOCK WASHER	M55	1
6	LOCK NUT	MN55	1
7	BALL BEARING 6207Z	BR-6207	1
8	BALL BEARING 6010Z	BR-6010	2
9	KEY	KR-1/4*1/4*100	1
10	KEY	KR-09*14*52	1

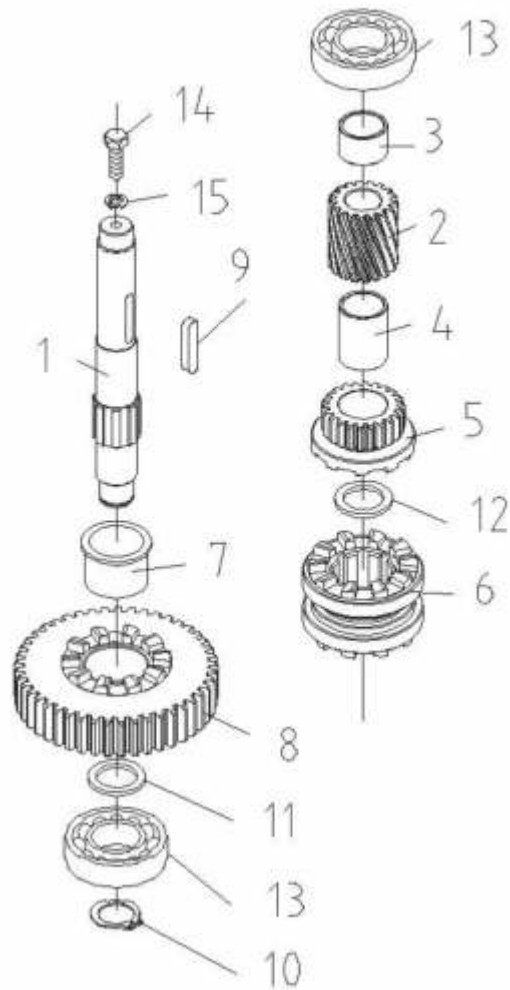

	Description or Name	Part No.	Qty
1	GEAR SHAFT	11100B-03-001	1
2	GEAR(6T)	11100B-03-002	1
3	WASHER	11100B-03-003	1
4	CLUTCH COPPER BUSHING	11100B-03-004	1
5	GEAR(9T)	11100B-03-005	1
6	SHIFTING CLUTCH	11091-03-002	1
7	CLUTCH COPPER BUSHING	11100B-03-007	1
8	GEAR(2T)	11100B-03-008	1
9	KEY	KRR-08*08*43	1
10	G TYPE SNAP RING S25	STW-S25	1
11	WASHER	1100B-03-011	1
12	WASHER	11100B-03-012	1
13	BALL BEARING 6205	BR-6205	1
14	BOLT 3/8*1/2	S-3/8*1/2	1
15	SPRING WASHER	SW3/8	1

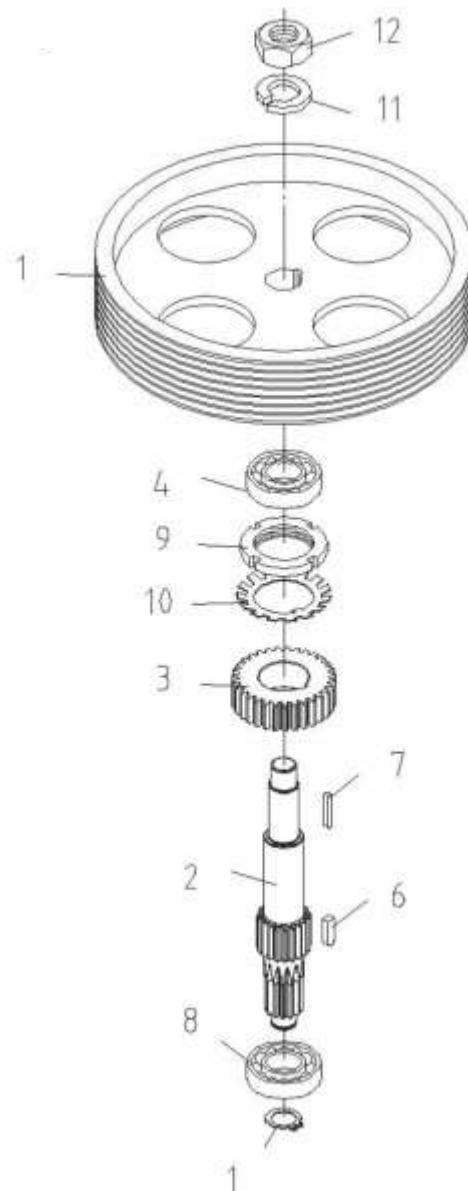

	Description or Name	Part No.	Qty
1	PULLEY	11092-03-001	1
2	GEAR SHAFT	11100B-04-001	1
3	GEAR(22T)	11100B-04-004	1
4	BALL BEARING 6206	BR-6206	1
5	G-TYPE SNAP RING S25	STW-S25	1
6	KEY 1/4*1/4*50	KR-1/4*1/4*50	1
7	KEY	KRR-10*08*28	1
8	BALL BEARING 6205	BR-6205	1
9	LOCK WASHER	M40*1.5P	1
10	LOCK NUT	MN40	1
11	SPRING WASHER	SW-1/2	1
12	NUT	W1*12NF	1

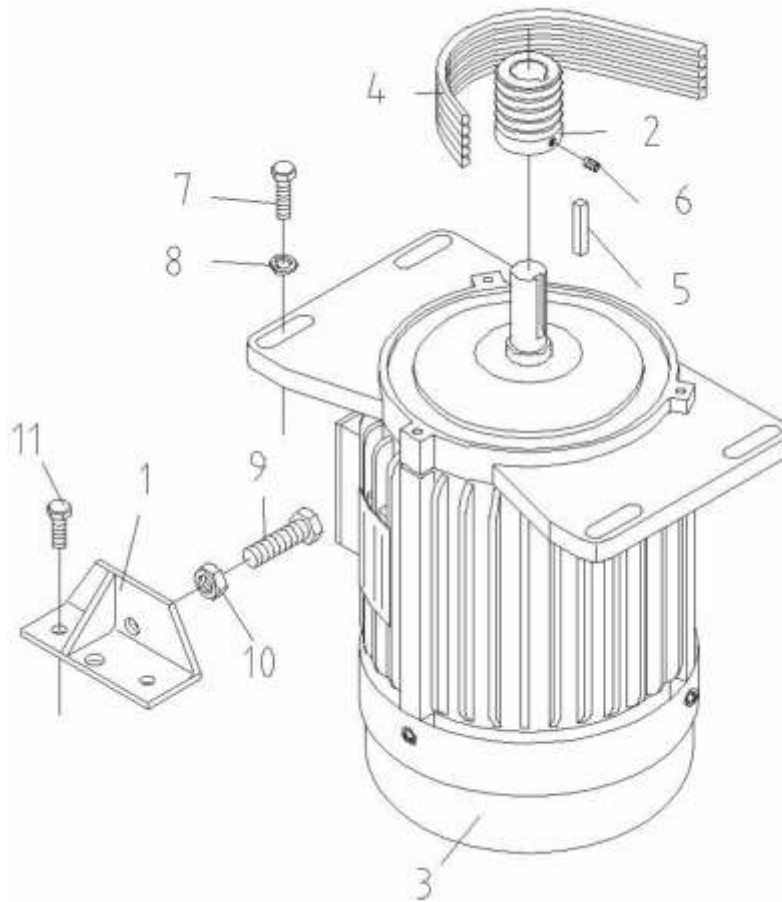

	Description or Name	Part No.	Qty
1	Motor Fixed Seat	11092-05-006	1
2	MOTOR PULLEY	11092-05-003	1
3	MOTOR	11092-05-005	1
4	BELT	M7*1320	8
5	KEY 7*7*40	KR-7*7*40	1
6	SET SCREW 1/4*5/8	S-S1/4*5/16	1
7	BOLT 3/8*3/4	S-3/8*3/4	4
8	WASHER 3/8"	W-3/8	4
9	BOLT 1/2*4	S-1/2*4	1
10	NUT	NUT-W1/2"*12NC	1
11	BOLT 3/8*3/4	S-3/8*3/4	2

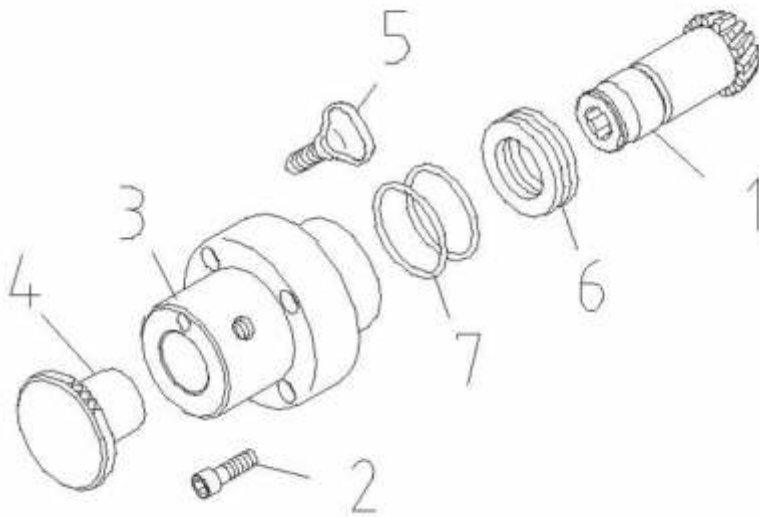

	Description or Name	Part No.	Qty
1	GEAR(14T)	11093-06-001	1
2	CAP SCREW 5/16*1/4	S-C-5/16*1-1/4	4
3	HUB ATTACHMENT	11093-06-002	1
4	ATTACHMENT HOLE PLUG	11091-06-004	1
5	THUMB SCREW	11031-06-005	1
6	BALL BEARING 2907	BR-2907	1
7	O SNAP RING P35	OR-P35	2



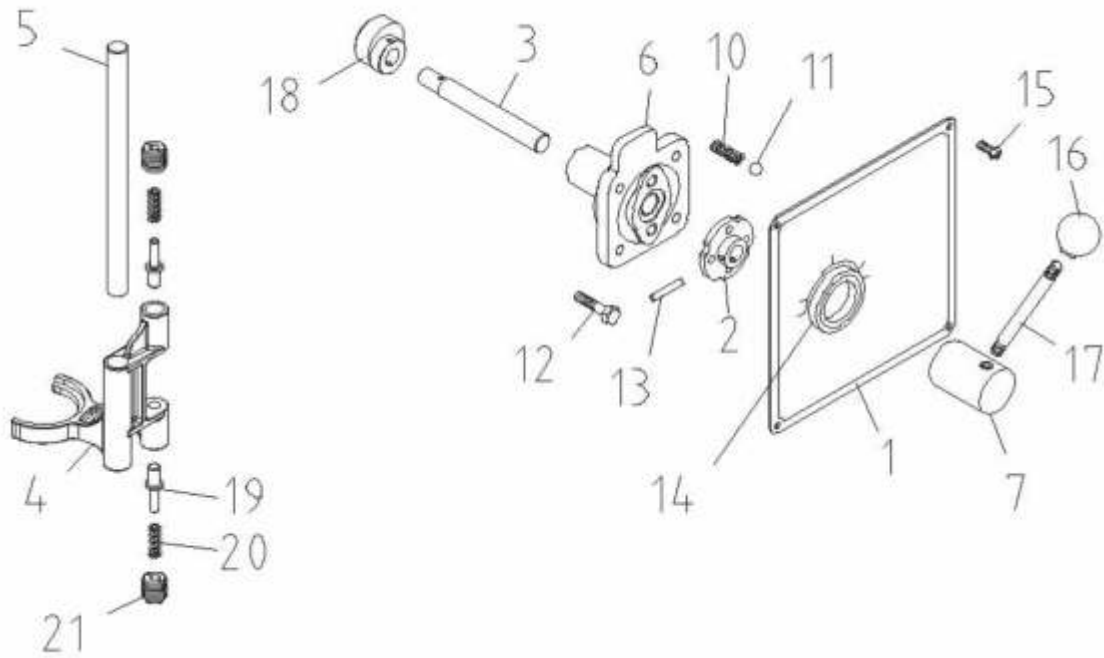

	Description or Name	Part No.	Qty
1	CONTROL PANEL	1109S-01-006D	1
2	HUB & CAM ASSY.	1109S-07-013B	1
3	ECCENTRIC SHIFT SHAFT	1109S-07-003B	1
4	SHAFT FORK	11091S-07-004B	1
5	SHIFTER FIXED SHAFT	11091S-07-005B	1
6	BRACKET GEAR SHIFT	11091-07-006	1
7	HANDLE SEAT	11092-07-007	1
8	NUT 1/2*12NC	NUT-1/2*12NC	1
10	COMPRESSION SPRING	11091-07-018	2
11	STEEL BALL 6	SB-6	2
12	SCREW	S-C5/16*5/8	4
13	SPRING PIN 5*28	SPP-5*28	1
14	OIL SEAL TC38*50*07	OS-TC38*50*07	1
15	MACH SCREW 3/16*3/8	S+R3/16*3/8	4
16	SHIFT HANDLE <del>KIB</del>	11091-07-012	1
17	SHIFT HANDLE	11091-07-001	1
18	SHIFTING CAM	11091S-07-008B	1
19	PLUNGER	11091S-07-009B	1
20	COMPRESSION SPRING	11091-07-010	2
21	SETSCREW	11091-07-011	2

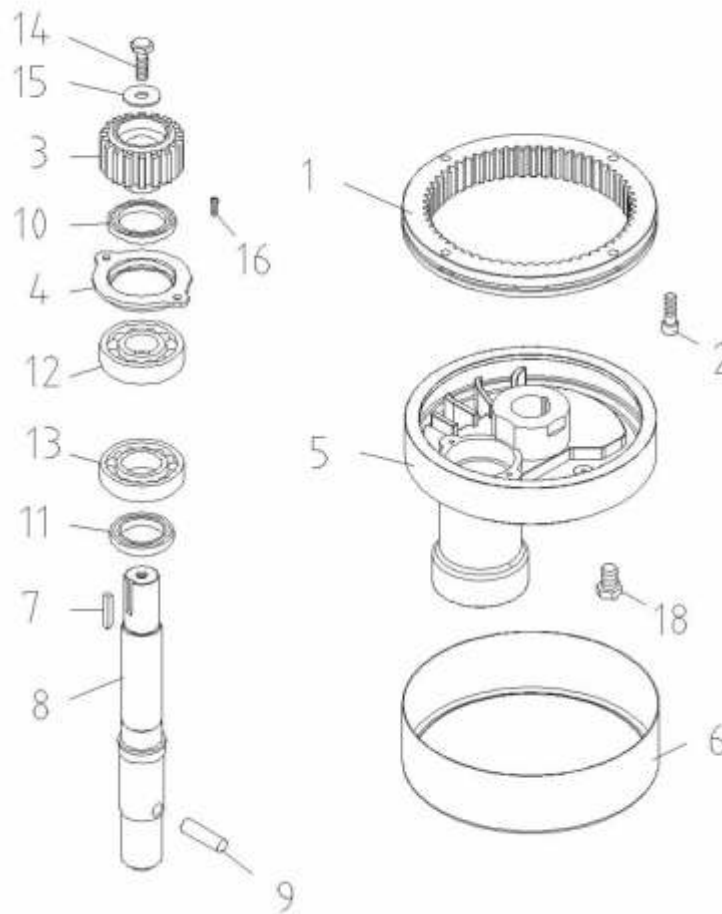

	Description or Name	Part No.	Qty
1	INTERNAL DRIVE GEAR(59T)	11091-08-001	1
2	CAP SCREW 3/8*1/4	S-C-3/8*1-1/4	4
3	INTERNAL PINION (18T)	11091-08-003	1
4	RETAINER	11091-08-004	1
5	PLANETARY HEAD	11091-08-005	1
6	HEAD RING	11091-08-006	1
7	KEY 6*6*35	KR-6*6*35	1
8	AGITATING SHAFT	11091-08-008	1
9	TAPERED PIN	11091-08-009	1
10	OIL SEAL TC43*58*08	OS-TC43*58*08	1
11	OIL SEAL TC40*72*10	OS-TC40*72*10	1
12	BALL BEARING 6306Z	BR-6306Z	1
13	BALL BEARING 6207Z	BR-6207Z	1
14	CAP SCREW 3/8*1	S-C-3/8*1	1
15	WASHER 3/8"	WB-3/8	1
16	MACH SCREW 1/4*5/8	S+R1/4*5/8	2
18	BOLT 12*3/4	S-1/2*3/4	1

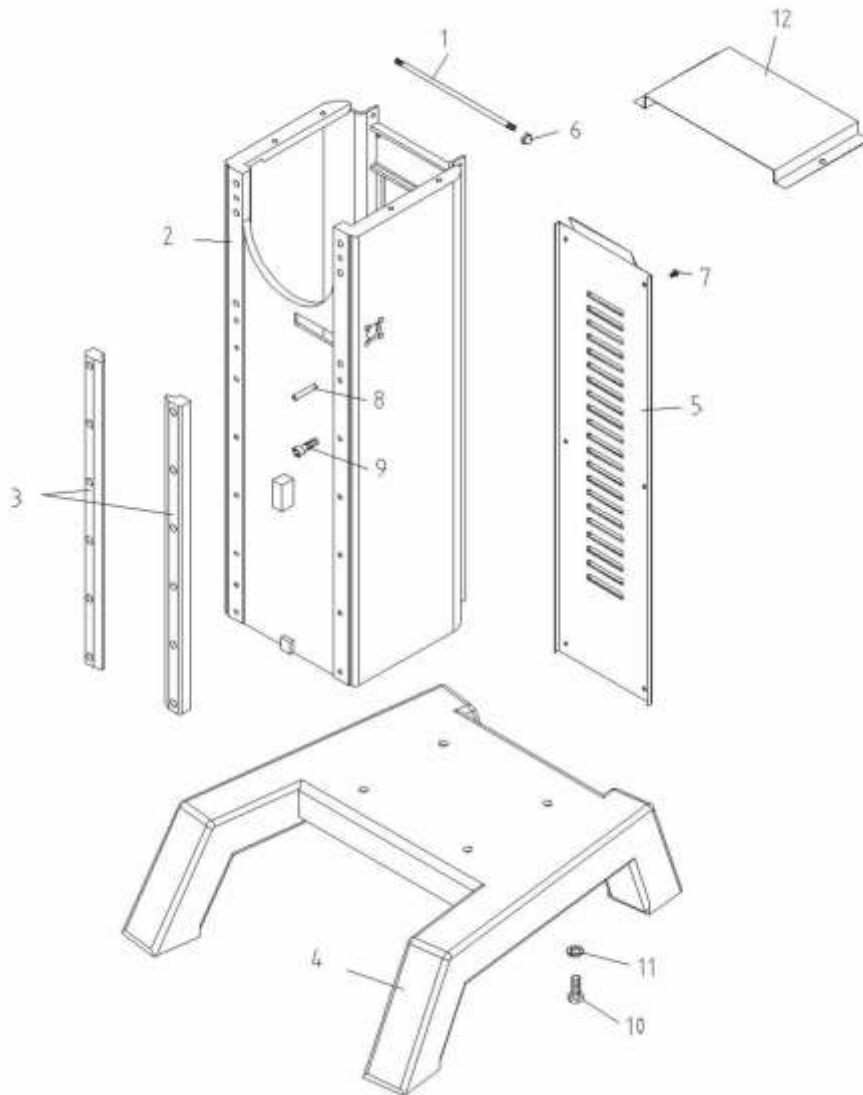

	Description or Name	Part No.	Qty
1	HINGE SCREW	11091-09-001	1
2	COLUMN	BM60-09-002	1
3	SLIDEWAY	11091-09-003	2
4	BASE	11091S-09-004C	1
5	COLUMN COVER	11091-09-005	1
6	NUT 5/16*18NC	NUT-5/16*18NC	2
7	BOLT 1/4*3/8	S-1/4*3/8	8
8	SPRING PIN 8*50	SPP-8*50	4
9	CAP SCREW 3/8*1/2	S-C-3/8*1-1/2	12
10	BOLT 5/8*3	S-5/8*3	4
11	SPRING WASHER 5/8"	SW-5/8	4
12	APRON	AXM60-09-016	1

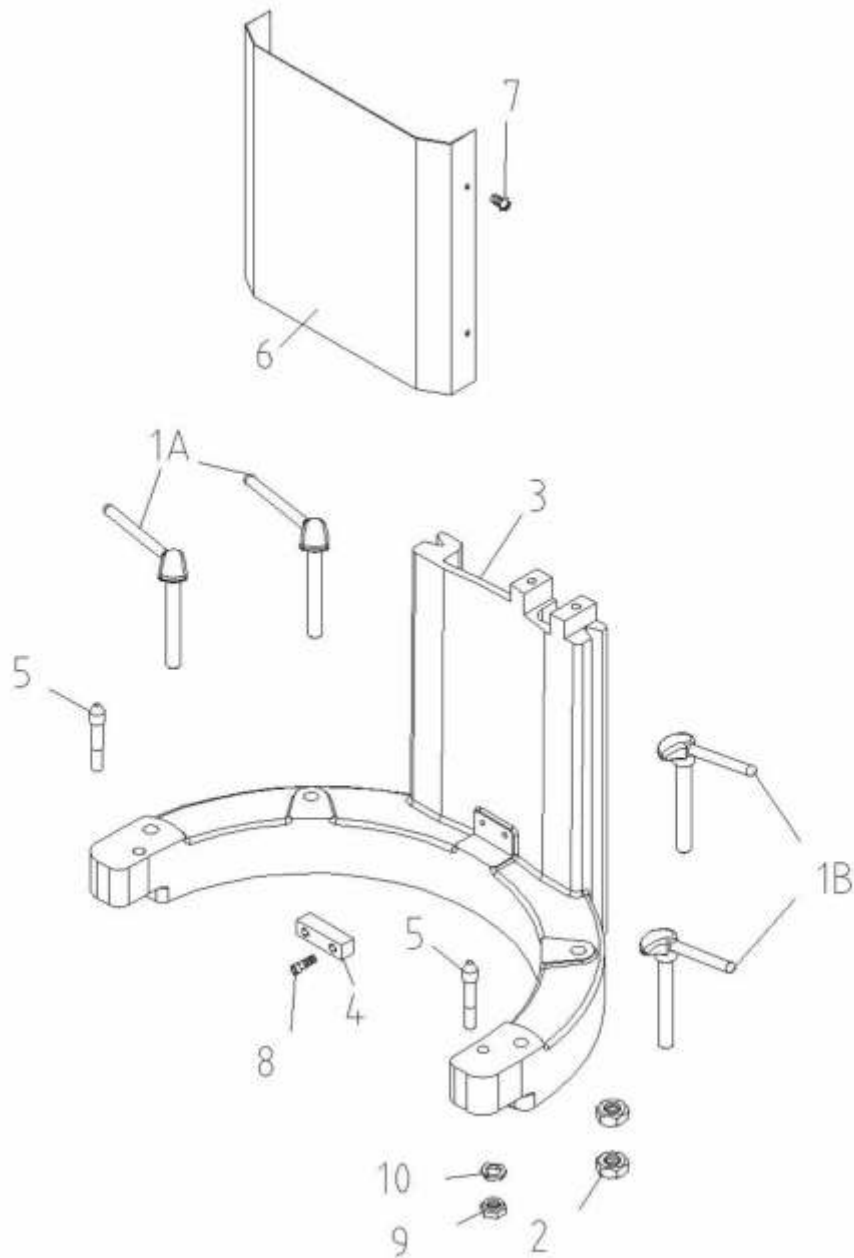

	Description or Name	Part No.	Qty
1	BOWL CLAMP(LEFT)	11091-10-001A	2
1	BOWL CLAMP(RIGHT)	11091-10-001B	2
2	NUT 5/8*11NC	NUT-5/8*11NC	4
3	BOWL SUPPORT	11091-10-003	1
4	BOWL RETAINER	11091-10-004	1
5	BOWL LOCATING PIN	11091-10-005	2
6	APRON	11091-10-006	1
7	MACH SCREW 3/16*1/4	S+R3/16*1/4	4
8	CAP SCREW 1/4*3/4	S-C-1/4*3/4	2
9	NUT 1/2*12NC	NUT-1/2*12NC	2
10	SPRING WASHER 1/2"	SW-1/2	2

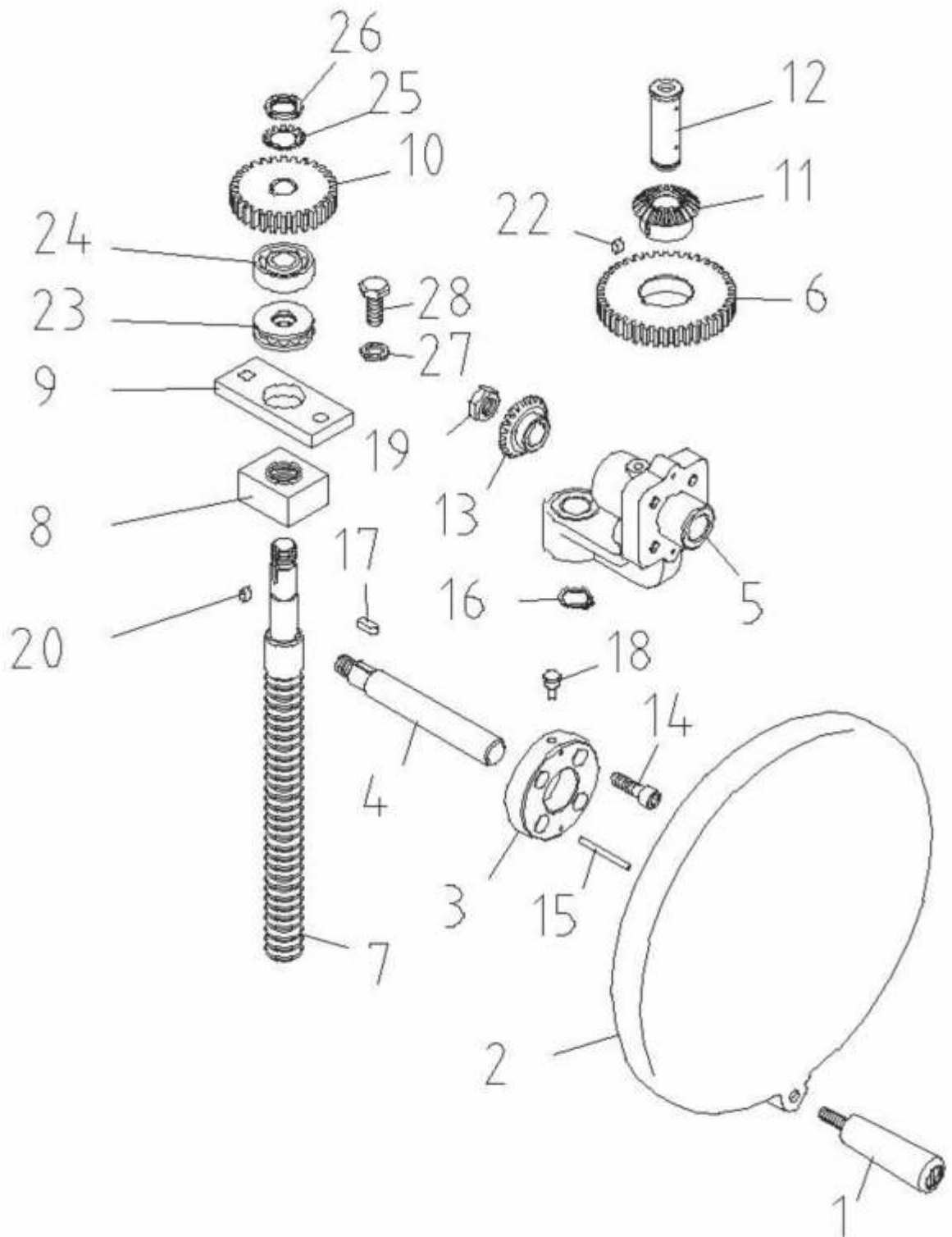

	Description or Name	Part No.	Qty
1	WHEEL HANDLE	11091-11-001	1
2	LIFTING WHEEL	11091-11-002	1
3	CLAMPING ARM	11091-11-003	1
4	WHEEL HANDLE	11091-11-004	1
5	WHEEL BRACKET	11091-11-005	1
6	LIFTING GEAR (41T)	11091-11-006	1
7	LIFTING SCREW	BM60-11-007	1
8	LIFTING NUT	11091-11-008	1
9	RETAINER	11091-11-009	1
10	GEAR (31T)	11091-11-010	1
11	BEVEL GEAR (23T) LIFTING	11091-11-011	1
12	SHAFT	11091-11-012	1
13	BEVEL GEAR (23T) WHEEL	11091-11-013	1
14	CAP SCREW 5/16*1/2	S-C-5/16*1-1/2	4
15	TAPERED PIN 4*32	TP-4*32	2
16	G-TYPE SNAP RING S19	STW-S19	1
17	KEY 5*5*15	KR-5*5*15	1
18	OIL CUP	( 丑 ) OIL-BELL-1/8*3/4	1
19	NUT 1/2*12NC	NUT-1/2*12NC	1
20	KEY 5*5*10	KRR-5*5*10	1
21	FLAT WASHER	WB-3/4	1
22	KEY 5*5*13	KRR-5*5*13	1
23	BALL BEARING 2903	BR-2903	1
24	BALL BEARING 6203	BR-6203	1
25	LOCK WASHER 17	M17	1
26	LOCK NUT	MN17	1
27	SPRING WASHER 3/8"	SW-3/8	2
28	BOLT 3/8*1	S-3/8*1	2

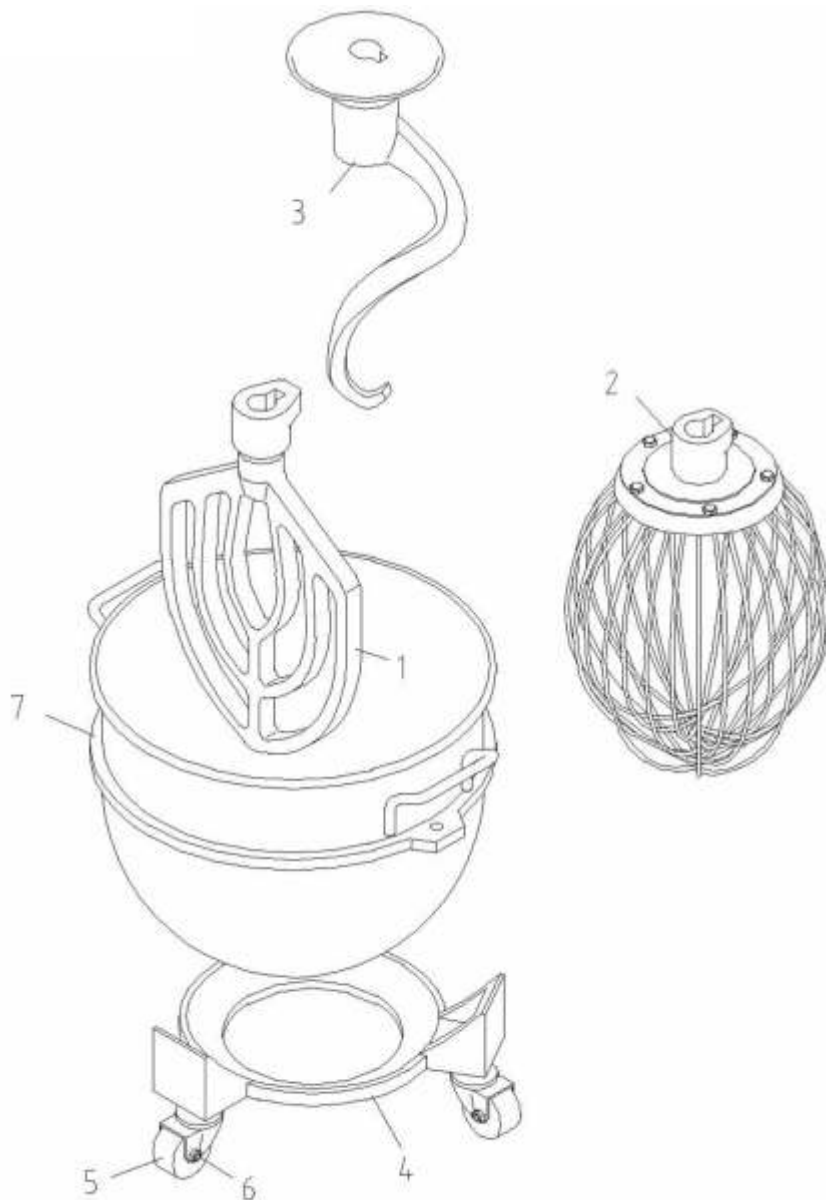

	Description or Name	Part No.	Qty
1	BEATER	11091-12-001	1
2	SS WHIP	11091-12-002	1
3	HOOK	11091-12-003	1
4	TROLLEY BASE	11091-12-011	1
5	WHEEL 2.5"	WHEEL-001	3
6	NUT 1/2*12NC	NUT-1/2*12NC	3
7	BOWL	11091-12-008	1



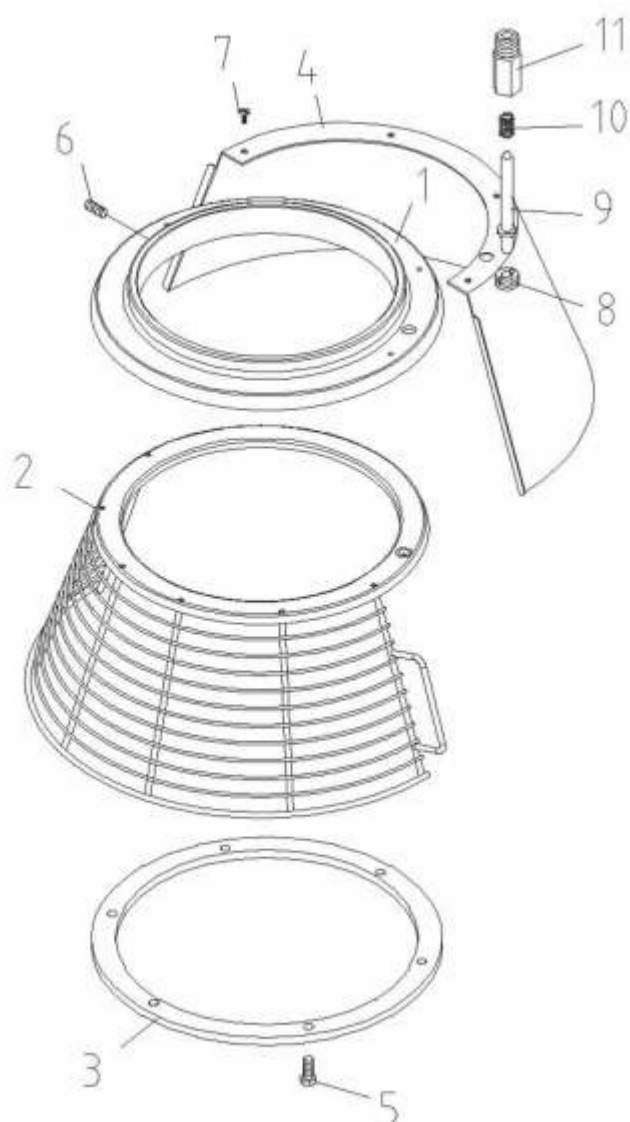

	Description or Name	Part No.	Qty
1	BACK COVER	GM60-13-001A	1 只
2	FRONT COVER (WIRE)	GM60-13-002B	1 只
3	FIXED RING	11091-13-003A	1 只
4	FIXED SHEET	11091-13-004	1 只
5	BOLT 3/16*1/2	S-3/16*1/2	6 支
6	SET SCREW 5/16*3/8	S-S5/16*3/8	3 只
7	SCREW	S+BR-3/16*1/4	4 支
8	SCREW	1109P-13-008	1 只
9	CONTROL SHAFT	11091-13-007	1 只
10	COMPRESSING SPRING	11091-13-012	1 只
11	CONTROL SHAFT SEAT	1109P-13-006	1 只

## GREASE AND OIL

for AX-M60 (AXIS M-60 s/n: 07040051 the machine is made before May 30, 2008).

And the AXIS M-60 s/n: 07040051 is use grease in the transmission & planetary head.

But since May 30, 2008, the AXIS M-60 is all use oil.

SHELL DARINA Ep0 (GADUS) should be applied to the gear-box of mixers ranging from 7QT to 40QT, while SHELL SPIRAX S2 A is for either gear-box or planetary head for only 60QT and 80QT.

## GREASE

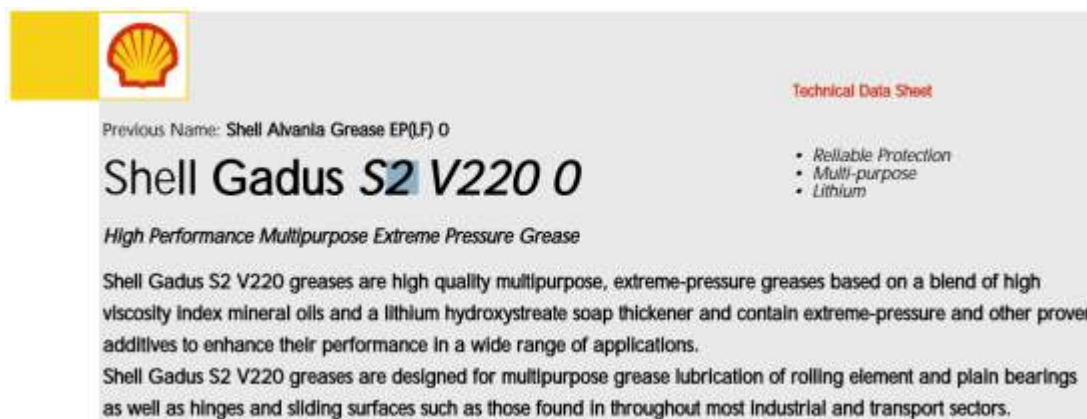

## OIL

### SHELL SPIRAX® HD

Heavy-duty gear oil for automotive differentials and manual transmissions

Product Description

Shell Spirax®

HD oils are high performance multigrade extreme-pressure, multipurpose gear lubricants. They are suitable for heavy-duty truck and automotive differentials, manual transmissions and oil lubricated wheel bearings. drive-train gears of heavy-duty automotive, trucking and off-road equipment operated under high-speed/shock load, high-speed/low torque and low-speed/high torque conditions. They meet the requirements of API GL-5 and MIL-PRF-2105E and are available in two SAE viscosity grades: 80W-90 and 85W-140.

	Grease in Gear-box			Grease in planetary head		
			Grease type			Grease type
<b>7 QT.</b>	0.25 lit.	8.45 us fl oz	S2 V220 0	0.055 lit.	1.86 us fl oz	JX-3-5G
<b>12 QT</b>	0.5 lit.	16.90 us fl oz	S2 V220 0	0.06 lit.	2.03 us fl oz	JX-3-5G
<b>20 QT.</b>	1 lit.	33.81 us fl oz	S2 V220 0	0.065 lit.	2.20 us fl oz	JX-3-5G
<b>30 QT.</b>	1.2 lit.	40.57 us fl oz	S2 V220 0	0.08 lit.	2.70 us fl oz	JX-3-5G
<b>40 QT.</b>	2.4 lit.	81.15 us fl oz	S2 V220 0	0.1 lit.	3.38 us fl oz	JX-3-5G
<b>60 QT.</b>	4 lit.	135.25 us fl oz	HD85W/140	0.3 lit.	10.14 us fl oz	HD85W/140
<b>80 QT.</b>	4 lit.	135.25 us fl oz	HD85W/140	0.3 lit.	10.14 us fl oz	HD85W/140



## Scheduled maintenance

**NOTE:** All maintenance work should be done only after unit has been disconnected from electrical power and grounding.  
 Never use a metal or stiff brush to clean the mixer. Never clean the mixer with water hose or any fluid under pressure.  
 Do not run the mixer for any extended period of time.

### Daily:

The mixer should be cleaned daily. Bowl and agitators should be removed from the mixer and cleaned in a sink with soapy warm water.

### Weekly:

The transmission case and planetary mechanism should be inspected weekly for leak and damages. Should it become necessary to repack the ball bearings, an authorized service technician or the manufacturer should be contacted. Use of unproven grease or oil (lubricant) may lead to damage and void the warranty.

### Monthly:

Verify bowl lift track and mechanism. The bowl lift track should be lubricated semiannually, or more often under heavy usage. Disconnect the unit from power supply before removing the top housing or apron. The drip cup should be inspected periodically for moisture or lubricant dripping. Remove the cup and wipe it with a soft cloth. Verify oil level inside the gear box.

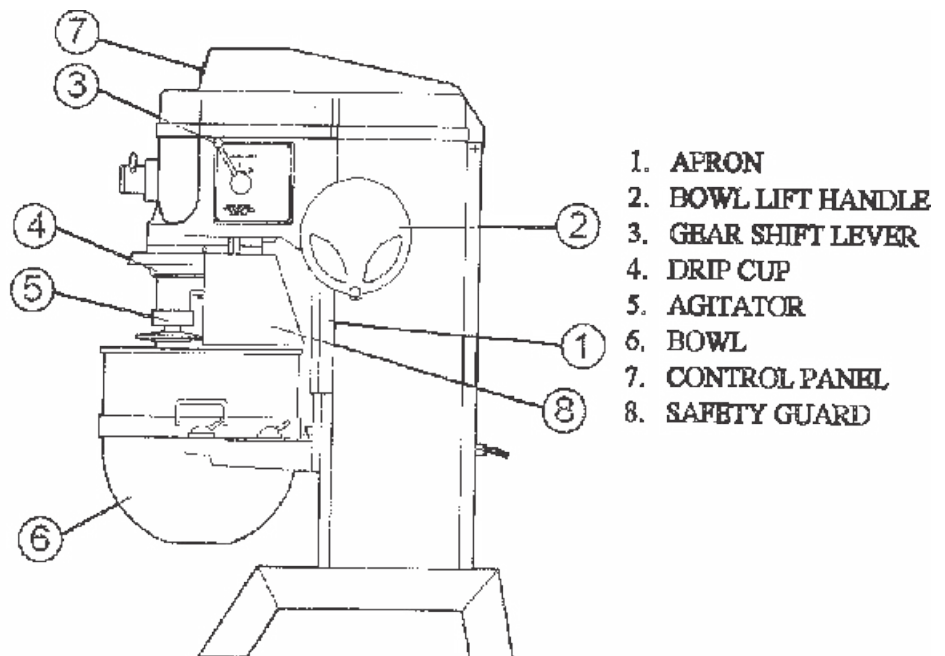

## Lubrication

The mixer comes with grease-packed ball bearing that do not require regular lubrication. When it becomes necessary to repack them, contact your local service company or MVP group Corp.

The polished drip cup protects against lubricant seeping out of the planetary into the bowl. The drip cup should be wiped clean monthly and inspected for excessive leakage. The drip cup may be removed by pulling it down.

The bowl lift track and mechanism requires periodic lubrication with a small quantity of high-quality mineral oil. This lubricant can be applied with a cotton swab or by fingertip.

## CLEANING

Never use a metal or stiff brush to clean mixer. Never clean the mixer with a water hose or any fluid under pressure.

The mixer should be thoroughly cleaned daily. It should be washed with a clean damp cloth.

Bowl and agitators should be removed from the mixer and cleaned in a sink.

The transmission case and planetary mechanism should be inspected weekly for leaks, damage, etc.





MAINTENANCE		DAILY	WEEKLY	MONTHLY
CLEANING	BOWL AGITATORS MIXER			
	VISUAL INSPECTION			
	PLANETARY BOWL LIFT BOWL GUARD TOUCH PAD GEAR BOX			
LUBRICATING	BOWL LIFT TRACK			

## WHAT LUBRICANT TO USE

Never use vegetable oil. Vegetable oil may look like a lubricant but it does not work as a lubricant. It will congeal, gum up and solidify, acting as a glue. If vegetable oil has been used, the entire track system must be cleaned and grease with proper lubricant. A mineral oil will do. There are no specific brands. It is easily found at the hardware store or pharmacy. See below for lubricants used inside the unit.

## GREASE AND OIL

For AX-M60 (AXIS M-60 s/n: 07040051, machine made before May 30, 2008) use grease in the transmission & planetary head.

But since May 30, 2008, the AXIS M-60 all use oil.

SHELL DARINA Ep0 (GADUS) should be applied to the gear-box of mixers ranging from 7QT to

40QT, while SHELL SPIRAX S2 A is for either gear-box or planetary head for only 60QT and 80QT.

	Grease and Oil in Gear-box			Grease and Oil in planetary head			Grease type
<b>7 QT.</b>	0.25 lit.	8.45 us fl oz	S2 V220 0	0.055 lit.	1.86 us fl oz	JX-3-5G	
<b>12 QT</b>	0.5 lit.	16.90 us fl oz	S2 V220 0	0.06 lit.	2.03 us fl oz	JX-3-5G	
<b>20 QT.</b>	1 lit.	33.81 us fl oz	S2 V220 0	0.065 lit.	2.20 us fl oz	JX-3-5G	
<b>30 QT.</b>	1.2 lit.	40.57 us fl oz	S2 V220 0	0.08 lit.	2.70 us fl oz	JX-3-5G	
<b>40 QT.</b>	2.4 lit.	81.15 us fl oz	S2 V220 0	0.1 lit.	3.38 us fl oz	JX-3-5G	
<b>60 QT.</b>	4 lit.	135.25 us fl oz	HD85W/140	0.3 lit.	10.14 us fl oz	HD85W/140	
<b>80 QT.</b>	4 lit.	135.25 us fl oz	HD85W/140	0.3 lit.	10.14 us fl oz	HD85W/140	



**MVP GROUP CORPORATION**  
12000 Biscayne Blvd, Suite #108  
Miami, FL, United States 33181  
Telephone: (786) 600-4687  
Toll Free Telephone: 1-844-218-8477  
Fax: (786) 661-4100  
Email: [service@mvpgroupcorp.com](mailto:service@mvpgroupcorp.com)



## AXIS M60P MIXER TECHNICAL MANUAL