



Depicted chain container optionally available.

Electric chain hoist model CPS with suspension hook

Capacity 125 - 500 kg

The model CPS is the smallest and lightest model within the range of Yale electric chain hoists. Reliability and compact design make it ideal for numerous applications in the construction industry, service companies and many industrial areas for moving small and medium loads.

Features

- Classification: 1 Am/M4 (standard), resp. 1 Bm/M3 at 230V, 1-phase, 50 Hz. As required the model CPS (with appropriate changes to lifting capacity resp. duty cycle) can also be re-classified.
- The standard version comes with direct control.
- Two year warranty (excluding wear parts).
- Thermal overload protection as standard.
- Duty cycle 30 % ED, resp. 25 % ED. 230V, 1-phase, 50 Hz.
- Safe hold of the load even in case of electric failure due to electromagnetic, spring pressure brake.
- Standard operating voltage: Euro-voltage 400 V, 3-phase, 50 Hz, resp. 125 kg also as 230V, 1-phase, 50 Hz version.
- Motor protected to IP 54, against ingress of dust and splashing.
- Push-button pendant control, IP 65 against ingress of dust and water jets from all directions.
- The overload protection (slip clutch) avoids overloading and extends the lifetime of the hoist.
- Robust aluminium housing, powder coated.
- Extremely low headroom
- The standard case hardened and zinc-plated link chain is matched perfectly to the load chain to guarantee smooth and precise chain motion. All requirements of national and international standards and regulations are fulfilled.
- The 10-pocket load sheave ensures smooth running of the chain and minimizes chain wear.
- Drop forged suspension and load hooks are made from non-aging, high tensile steel and fitted with robust safety latches.

Festooned cable systems
see pages 138-139.

Options

- Stainless steel load chain (no reduction of working load limit).
- Robust chain container
- Low voltage control 48 V
- Manual and electric trolleys.
- Connection to festooned cable systems.

Technical data model CPS

Model	EAN-No. 4025092*	Capacity in kg/ number of chain falls	Standard lifting height m	Chain dimensions d x p mm	Classification FEM/ISO	Lifting speed m/min	Hoist motor kW	Weight kg	Operating voltage
CPS 1-4	*076654	125/1	3	4 x 12.2	1 Bm/M3	4	0.10	11.5	230V/1 Ph/50 Hz
CPS 1-10	*076661	125/1	3	4 x 12.2	1 Am/M4	10	0.25	11.5	400V/3 Ph/50 Hz
CPS 2-6	*076678	250/1	3	4 x 12.2	1 Am/M4	6	0.28	11.5	400V/3 Ph/50 Hz
CPS 5-3	*076685	500/2	3	4 x 12.2	1 Am/M4	3	0.28	12.5	400V/3 Ph/50 Hz

Dimensions model CPS

Model	CPS 1-4	CPS 1-10	CPS 2-6	CPS 5-3
A, mm	276	276	276	303
B, mm	98	98	98	146
C, mm	159	159	159	159
D, mm	75	75	75	60
E, mm	76	76	76	91
F, mm	160	160	160	160
G, mm	227	227	227	227
H, mm	103	103	103	103
I, mm	52	52	52	52
J*, mm	1905	1905	1905	1905
X, mm	25	25	25	25
Y, mm	14	14	14	14
Z, mm	21	21	21	21

*Dimensions at standard lift (3 m).

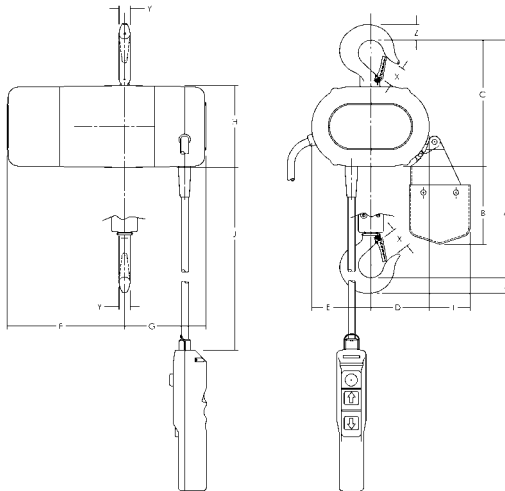

Smallest and lightest electric chain hoist for a great number of applications.

! Yale hoists and trolleys are not designed for passenger elevation applications and must not be used for this purpose.