

CHAIN HOIST



Excludes
¼ Ton Model

Features

- All-steel construction
- Long lasting powder coat finish
- Minimal load lifting effort
- 100% load tested Grade 80 alloy chain
- Weston-Style brake system with twin pawl design
- Zinc plated hand chain
- Fully-enclosed gearing
- Load sheave bearings
- Forged alloy steel hooks
- Thrust bearing on lower hook
- Heavy-duty latches

Standards - CE, ASME B30.16 and AS1418.2

OZIND020-CH

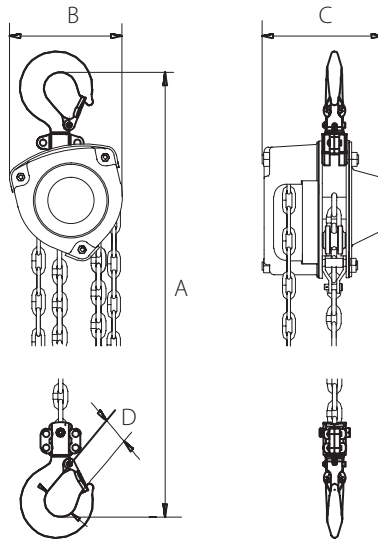

	OZIND025-CH	OZIND005-CH	OZIND010-CH	OZIND020-CH
Capacity (tons)	0.25	0.5	1	2
Effort to Lift S.W.L (lbs)	55	55	66	88
Falls of Chain	1	1	1	1
Load Chain Diameter (mm)	4x12	5x15	6x18	8x24
Product Dimensions (in)	A	10.2	12.8	14.6
	B	4.18	5.35	5.75
	C	4.02	5.2	5.98
Hook-opening, Upper & Lower	D	1.3	1.38	1.73
Net Weight (lbs)	4	10	16	19

*Standard Lift: 10, 15, 20, and 30 ft

*.25 T Models Standard Lift: 10 ft.

We also do custom rigging

*Dimensions are for reference only and subject to change without notice.

