

Manual Chain Hoists

Chainfalls, CF-Series

1/2 through 5 Ton capacity

Harrington CF hand chain hoists give you a practical alternative thanks to an economical design using fewer parts for trouble-free service. Outstanding durability is due to a die-cast aluminum body and high-strength, heat-treated main pinion shaft and load gear. Pre-lubricated ball bearings, precision machined gears, and Weston-style load brake make lifting smooth and easy while allowing long service and low maintenance.

Many Benefits From More Features:

- Experience exceptional strength with a thick die-cast aluminum body.
- Handle tough demands with high-strength, heat-treated main pinion shaft and load gear.
- Get positive braking action with Weston-style load brake incorporating two moisture-resistant brake pads with four braking surfaces.
- Minimize manual effort thanks to smooth running, pre-lubricated ball bearings, and precision machined drive train components.
- Simplify maintenance with fewer parts and an easy-to-work-on design.

Capabilities To Count On:

- 10-foot lift is standard, 15- and 20-foot lifts are also stocked; nonstandard lifts and hand chain drops available as well.
- Grade 100 heat-treated manganese alloy load chain resists abrasion and wear while minimizing chain weight.
- Forged and heat-treated alloy steel hooks are designed to open slowly and not fracture under excessive loads.
- Test certificate verifies that every hoist has been factory load tested to 125% of rated capacity, in accordance with ASME B30.16 requirements.

Options: (See Pages 28-29)

- Chain container
- Corrosion-resistant chain
- Inspection hook





Manual Chain Hoists

Chainfalls, CF-Series



CF HAND CHAIN HOIST — DIMENSIONS

Cap. (Tons)	Product Code	a (in)	b (in)	d (ft)	e (in)	f (in)	g (in)
1/2	CF005	5.4	5.9	10	2.0	2.4	1.1
1	CF010	5.8	6.9		2.3	2.9	
1 1/2	CF015	6.0	8.0		2.4	3.4	1.3
2	CF020	5.8			2.3	2.3	1.4
3	CF030	6.0	9.4		2.4	2.7	1.7
5	CF050		13.5			4.5	1.8

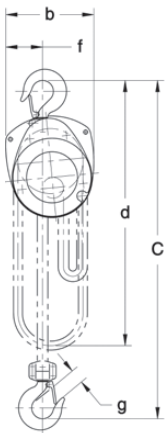

1/2 – 1 1/2 Ton

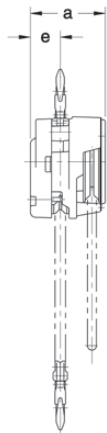

2 – 3 Ton

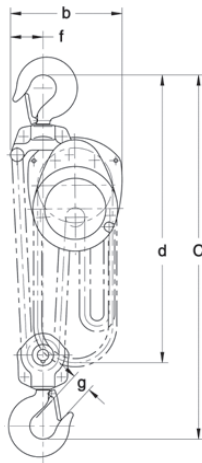

5 Ton

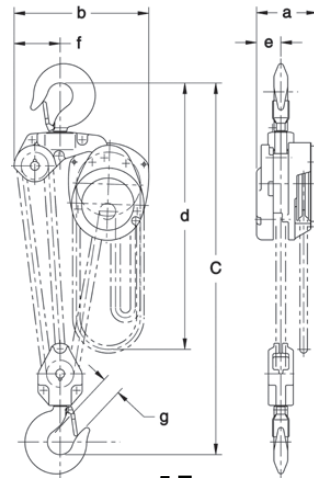
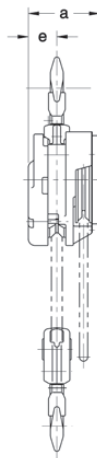

CF HAND CHAIN HOIST — SPECIFICATIONS

Cap. (Tons)	Product Code	Headroom C (in)	Std. Lift (ft)	Pull to Lift Load (lbs)	Overhaul Ratio	Load Chain Diameter (mm) x Chain Fall Lines	Net Weight (lbs)	Shipping Weight Approx. (lbs)	Weight for Additional One Foot of Lift (lbs)
1/2	CF005	12.8	10	60	19	5.0 x 1	24	26	1.0
1	CF010	14.6		72	31	6.3 x 1	29	31	1.2
1 1/2	CF015	17.3		84	41	7.1 x 1	40	42	1.4
2	CF020	20.1		80	63	6.3 x 2	47	49	1.8
3	CF030	23.2		92	81	7.1 x 2	62	66	2.1
5	CF050	24.4			134	7.1 x 3	82	86	2.9

Please Note: Special lengths of load and hand chain available upon request. Weights are approximate.