

ELECTRIC BUILDER'S HOIST



Features

- Lightweight and compact design for convenient mounting
- Built-in safety features and easy control of lifting for a wide range of applications
- Automatic shut-off when rope reaches limit arm
- Dynamic and mechanical brake provides instant and safe braking
- Upper and lower limit switches for additional safety
- Sensor arm for motor shut-off to prevent reverse winding
- Galvanized wire rope with 360-degree weighted hook includes safety latch
- Quick release pendant and power cords
- Standard 115V power source-compatible
- Wireless remote control for ease of use (Model OBHW600 only)
- Emergency UP / DOWN control switch (Model OBHW600 only)



Standards - CE

Specs

	OBH500	OBHW600	OBH1000
Capacity - Full Drum (lbs)	500	600	1000
Motor Voltage	115/1/60	115/1/60	115/1/60
Speed (fpm)	75	52	37
Motor (HP)	1.74	2	2.41
Motor KW	1300W/17.5A	1500W/12.5A	1800W/15.5A
Lifting Height (ft)	90	90	90
Wire Rope (in)	3/16	3/16	1/4
Gross Weight* (lbs)	54	49	73
Power cord length (ft)	15	15	15
Pendant length (ft)	65	n/a	65
Full Load (AMPS)	17.5	12.5	15.5
Duty Cycle (min)	15 (25%)	15 (25%)	15 (25%)

*Includes lower hook, power and pendant cable / *Includes lower hook and power cable (OBHW600)
100 ft. pendant length available

500, 600, 1000 LBS

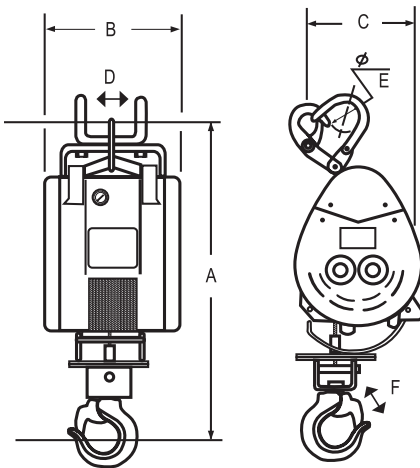

		OBH500	OBHW600	OBH1000
A (in)	Height	26.77	26.77	28.50
B (in)	Width	9.50	9.50	10.50
C (in)	Depth	7.88	9.06	12.00
D (in)	Hanger Inner Width	4.50	4.50	5.50
E (in)	Hanger Opening	2	2	2
F (in)	Hook Opening	1.62	1.62	1.50

*Dimensions are for reference only and subject to change without notice.

OBHW600



WARNING
CANCER AND REPRODUCTIVE HARM
 Some products may contain chemicals known to the state of California to cause cancer, or birth defect or reproductive harm.
www.P65Warning.ca.gov

MOUNTING AND LIFTING SOLUTIONS

Mounting Arm Bracket (Pipe-Mount and Wall-Mount)

- Long last powder coat finish
- Portable / Light Weight
- Made in USA
- Solid mounting bracket
- Quick mount



	OBH230	OBH230-WALL
W - Width (in)	40 1/2	40 1/2
H - Height (in)	17 3/4	17 3/4
D - Mounting Pipe (in)	2	N/A
Capacity (lbs)	1000	1000
Net Weight (lbs)	26	31

Pipe Not Included

OBH500

OBH500

Wall-Mount Bracket

Pipe Not Included



OZ05PBTA-OBH
Trolley with OBH Hanger
Contact us for more information.

Refer to OZ05PBTA dimensions on page 13



OZGBT-OBH
Geared Trolley with OBH Hanger
Contact us for more information.

Refer to OZ1GBT dimensions on page 15

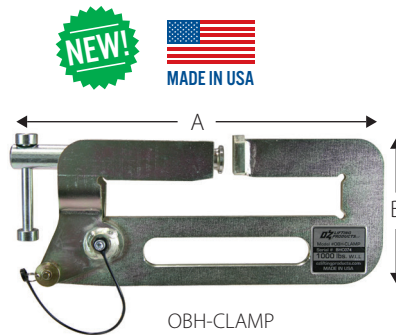

OBH-CLAMP
Builder's Hoist Beam Clamp

OBH-CLAMP	
A - Width (in)	13.5
B - Height (in)	5.375
Max flange width (in)	8
Capacity (lbs)	1000
Net Weight (lbs)	8

Contact us for more information.



OZBAG3
Hoist Bucket
Contact us for more information.

Hoist bucket rated at 150 lbs.