

Impregnation Table electric portable

Imprägniertisch elektrisch transportabel

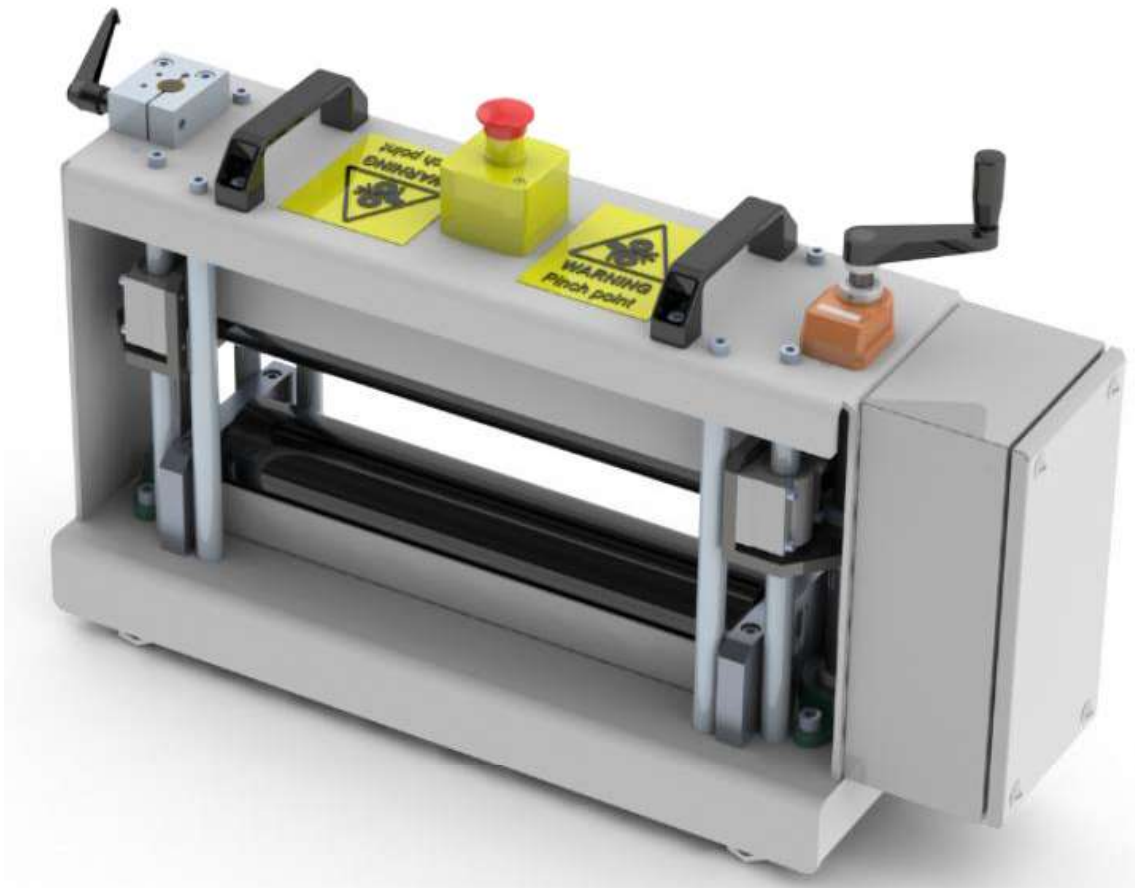

LCD DISPLAY NEW
ELECTRONIC GAP POSITION INDICATOR

Technical details

Technische Daten

Dimensions / Durchmesser Bereich: DN 300
(according to the customer needs / *nach Kundenwunsch*)

Weight / Gewicht: DN300 32kg

Power supply / Stromversorgung: 220 V / 50 Hz / 0,11 kW

Sanitable E300

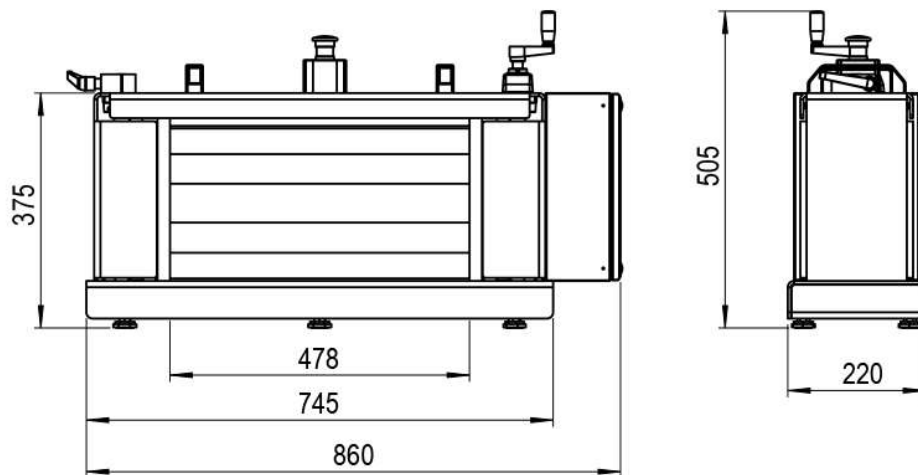

Sanitable E400

