

Impregnation Table electric with conveyor belt
Imprägniertisch elektrisch mit Transportband

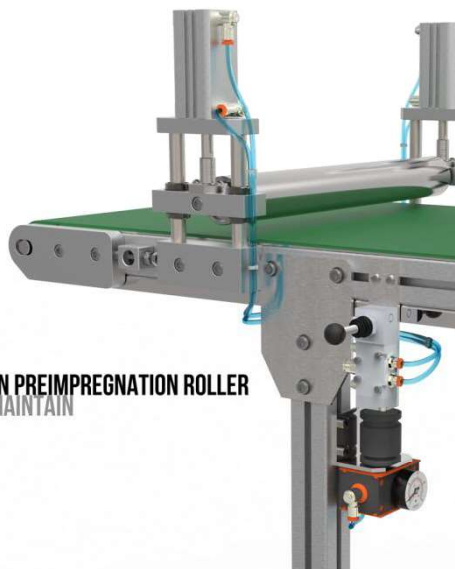

AIR DRIVEN PREIMPREGNATION ROLLER
EASY TO MAINTAIN



Technical details

Technische Daten

Dimensions / *Durchmesser Bereich*: DN 225 / DN 300 / DN 400

Weight / *Gewicht*: DN225 126kg / DN300 135kg

Power supply / *Stromversorgung*: 220 V / 50 Hz / 0,11 kW

Sanitable E225

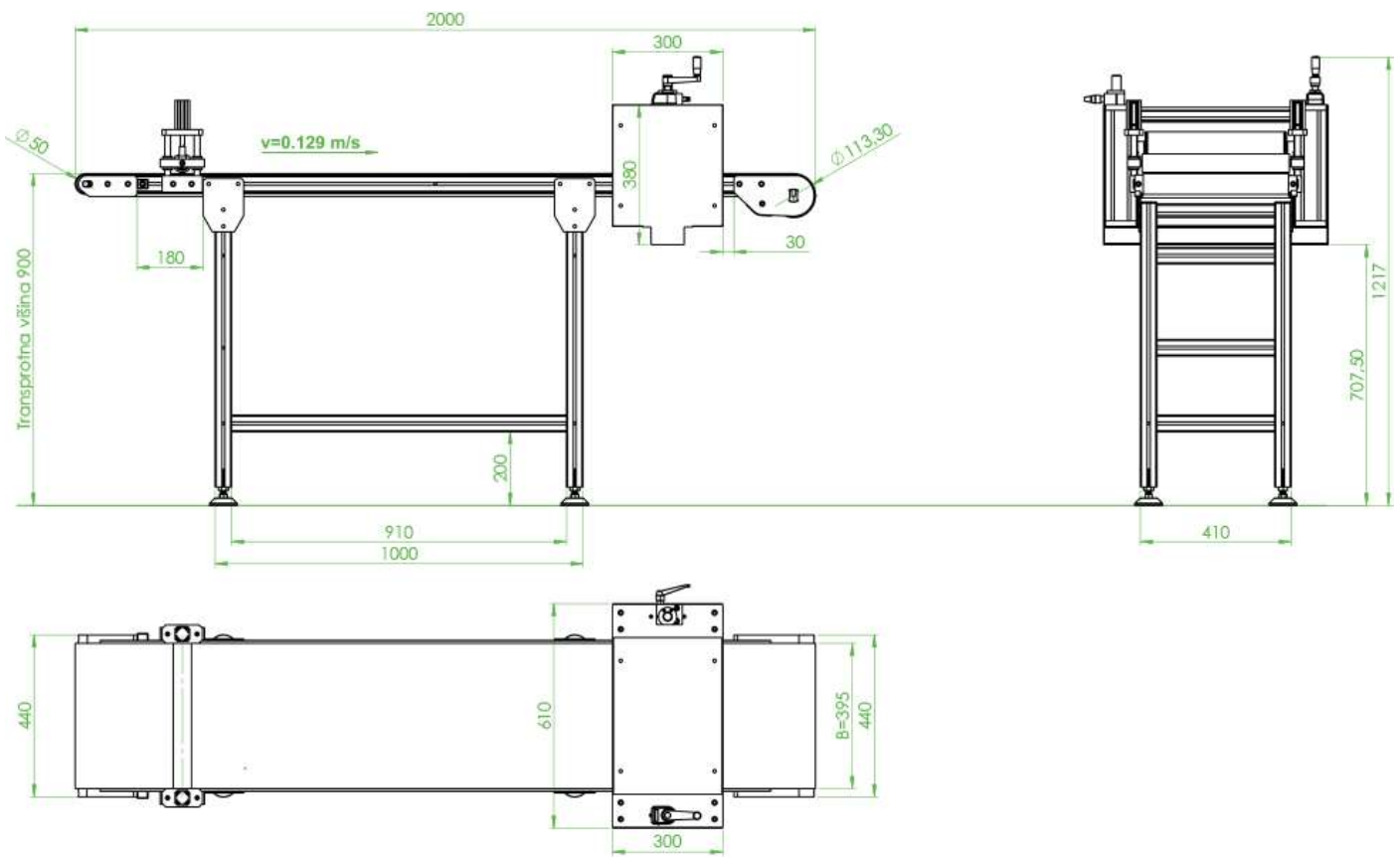

Sanitable E300

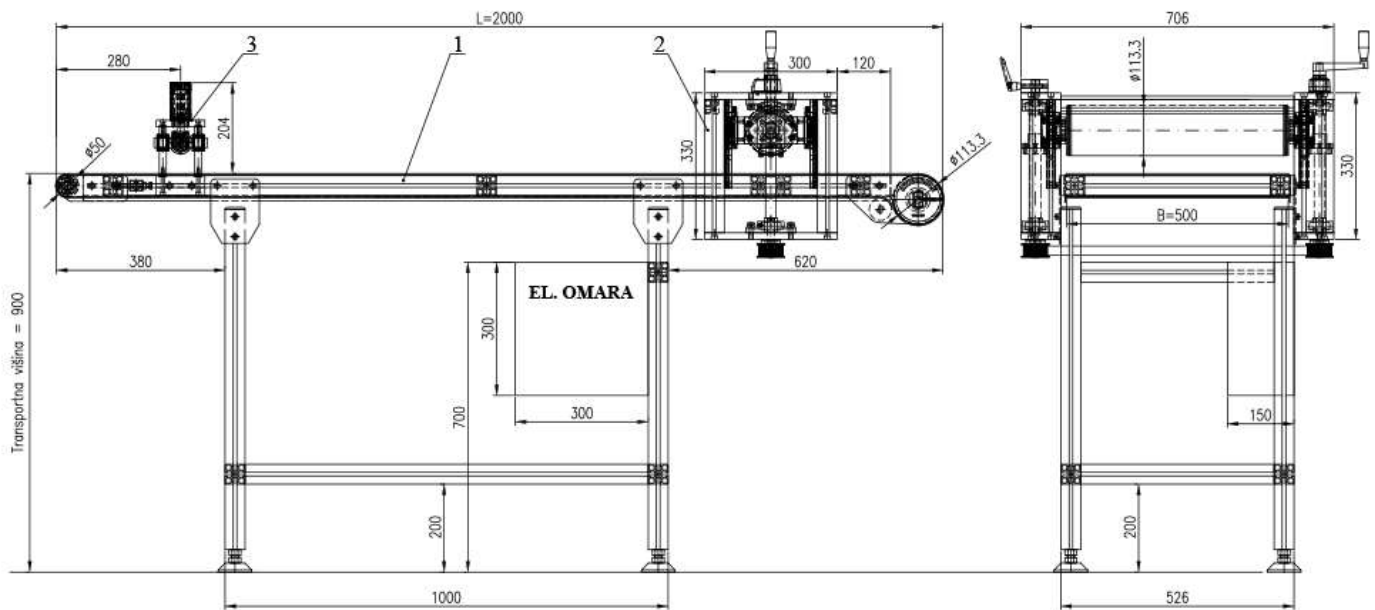

Sanitable E300

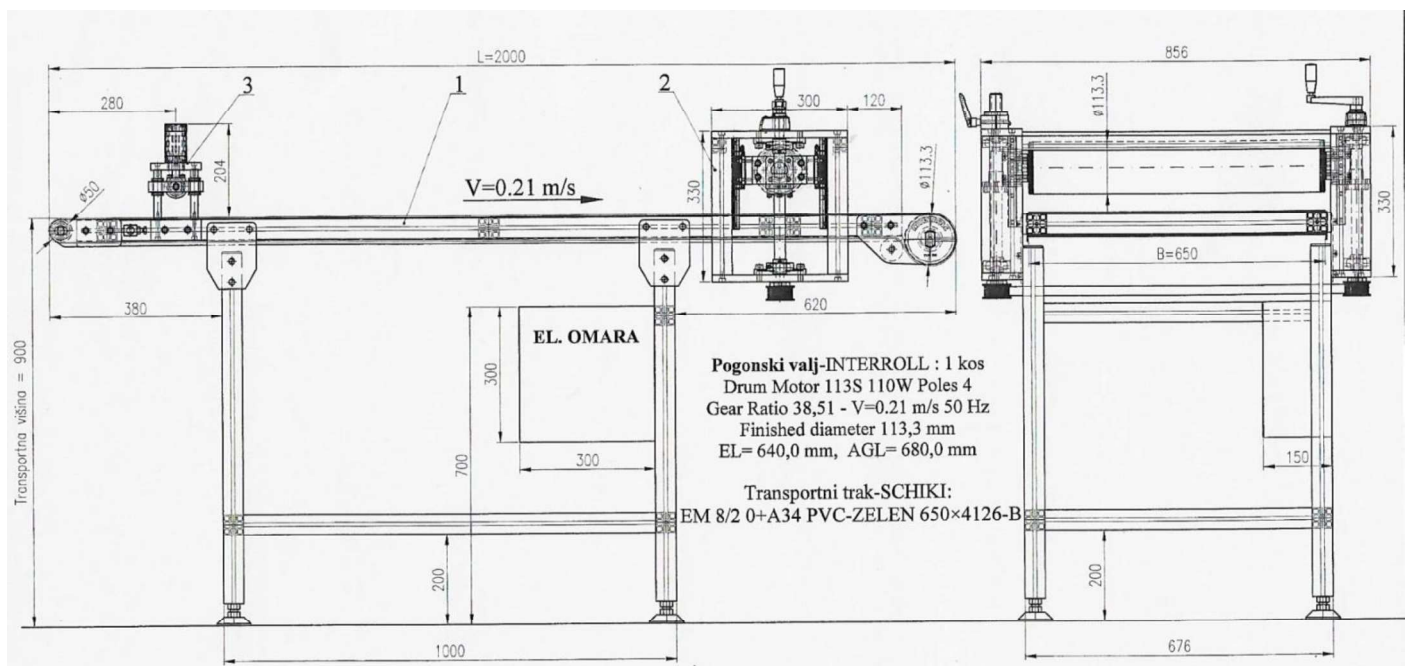

Conveyor belt width

Transportband breite

Sanitable E 225:	395 mm
Sanitable E 300:	500 mm
Sanitable E 400:	640 mm