



OWNER'S MANUAL

Alexis 27



Read all instructions carefully before use.

Royal Sovereign International Inc.

www.royalsovereign.com

TABLE OF CONTENTS

TOPIC	PAGE
1. Introduction	3
2. Package Contents	3
3. Safety Precautions.....	4
4. Parts	5
5. Features Guide	6
6. Operation Instructions	9
7. Film Loading and Threading	10
8. Maintenance	12
9. Trouble Shooting Guide	13
10. Specification	14
11. Warranty	15

1. INTRODUCTION

Thank you for purchasing RS Alexis 27. It has been designed and manufactured to provide years of continuous service. For high quality lamination, please read this instruction manual thoroughly. This manual will provide you with complete operating and maintenance information.

2. PACKAGE CONTENTS



- Owner's Manual
- Wrench
- Dust Cover
- Silicone Elastic

3. SAFETY PRECAUTIONS

Failure to comply with any of the following safety procedures could result in serious injury. Please read the instructions carefully and keep to future reference.

1. Only a licensed electrician should install wiring and outlet for the laminator.
2. Ensure the unit is plugged into a properly grounded outlet with the correct voltage.
3. Keep hands and clothing (i.e. Neckties) away from rollers. The rollers have pinch points that can trap body parts or clothing and cause serious injury.
4. Keep flammable and wet objects away from the machine.
5. Place machine on a level surface.
6. Avoid excessive sunlight, humidity and extreme temperatures.
7. Ensure the unit is turned off, cooled, and unplugged from the outlet prior to moving and or repairing.
8. Keep out of reach of children.
9. Only Royal Sovereign authorized maintenance and service technicians should make repairs.
10. Do not attempt to laminate items that exceed total recommended material thickness for the unit.
11. When cleaning the machine, don't use flammable sprays or materials.
12. Do not touch the rollers when they are hot or place foreign objects inside the machine.
13. Do not cover the surface of the machine until the machine has completely cooled.

4. PARTS

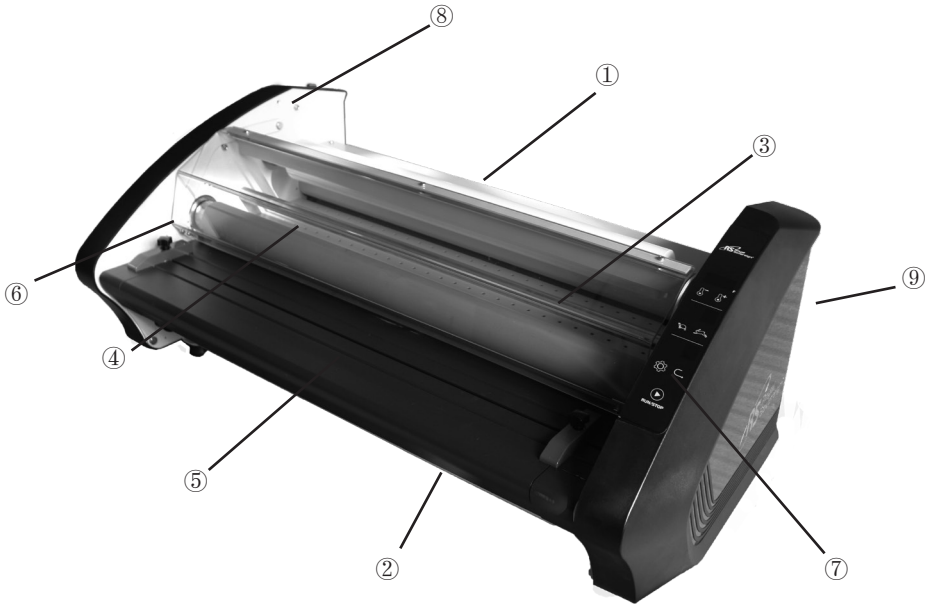

1.Upper Film

2.Lower Film

3.Idle Bar

4.Hot Rollers

5.Feed Table

6.Paper Guide

7.Control Panel

8.Tension Screw

9.Power Switch

5. FEATURES GUIDE

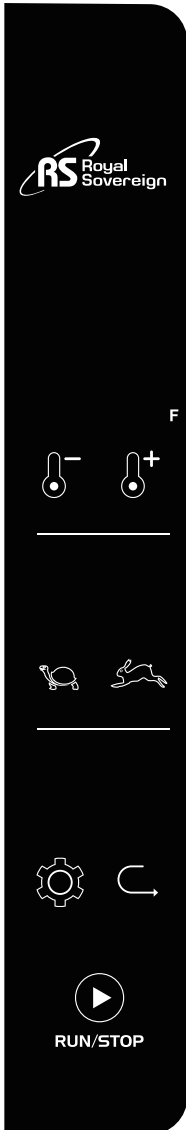







 RUN/STOP	Run and stop the machine.
	Mode: change default mode(1~4 settings).
	Reverse the rollers to undo jams and correct misfed documents .
	Reduce roller speed(9~1 setting).
	Increase roller speed(1~9 setting).
	Reduce roller temperature(302~176 F).
	Increase roller temperature(176~302 F).

Figure 1

Power Switch (1) - Located on the rear of the machine. "I" (on) "0" (off). (Fig. 2)

Cross Cutter (2) - Used to cut off the laminated web. (Fig. 2)

Main Fuse (3) - To cut off the main power circuit. It can recover by itself.

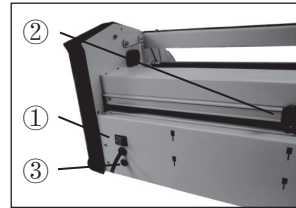

Figure 2

Feed Guide (4) -The feed guide permits alignment of the item(s) to be laminated. To position the adjustable guide, loosen the knob, slide it to the desired position and tighten the knob to secure the feed guide in place. (Fig. 3)

Safety Cover (5) - It prevents entanglement

NOTE: If the safety cover is opened, the power to the motor will turn off.

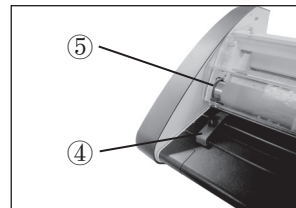

Figure 3

Film Shaft

The film shaft holds the film supply on the machine. (Fig. 4)

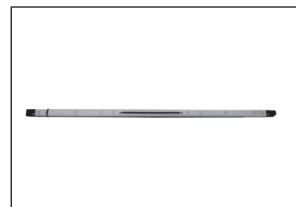

Figure 4

Film Tension Adjustment - Allows the operator to increase or decrease film web tension. clockwise to increase tension and to decrease tension turn the knob counterclockwise. (Fig. 5)



Figure 5

Emergency Switch (6) - To stop the machine in an emergency situation. (Fig. 6)

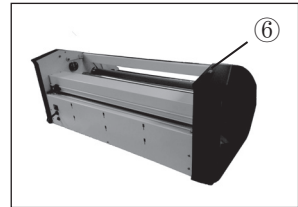

Figure 6

6. OPERATION INSTRUCTIONS

1. Turn the laminator ON (I) located on the rear of the machine. (Fig. 2)
2. Choose the appropriate speed (Fig.1)
3. Do not begin laminating until the blinking light is steady (approximately 8 minutes).
4. Position the item to be laminated on the feed table.
5. Press the RUN button. The rollers will begin to turn, wait for heat line to disappear, feed the item into the machine.
6. When using PET or OPP film laminate, please use a test print first to establish correct speed and temperature for that product. Keep a distance of 15mm between prints when running multiple prints through the laminator.
7. Stop the laminator when all of the items have completely exited the rear of the machine.
8. Please keep the film tension controls as loose as possible but still maintaining proper film flow over the rollers. Tighten as needed if film has slight wrinkles over the rollers.
9. If you find the temperature level is high while laminating with some films with thin paper on the high or middle level you can try using a lower temperature level. Repeat the above steps until all of your lamination is complete. When lamination is completed and the machine is not in use for an extended period of time, turn the power off.

NOTE: Stand by mode and auto power off mode

- **Stand by mode:** If no activity is made within 30 minutes after each use the machine will automatically switch into stand by mode. (In stand-by mode the temperature will decrease to 80~90 C and the three film thickness setting indicators will blink).
- **Auto power off mode:** If the machine is in stand by mode and no activity is made for 60 minutes the machine will automatically power off.
 - If any activity is made while in stand by or auto power off mode the machine will return to it's previous stage.

7. FILM LOADING & THREADING

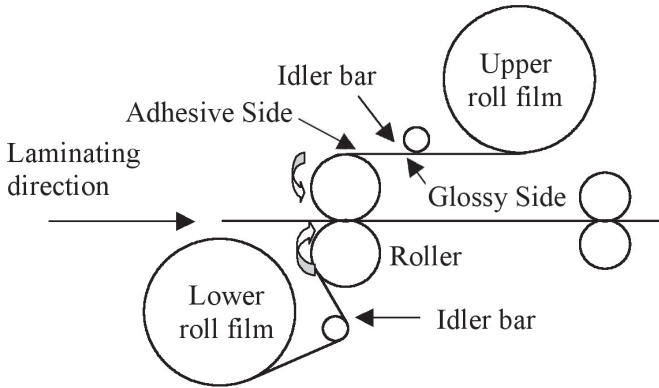

Figure 7

1. Slightly slide the shaft to the right and pull it out from the machine. (Fig. 8)



Figure 8

2. Set the rubber "O" ring to a suitable location base on the width of the file, make sure they are in the same location for both shaft.

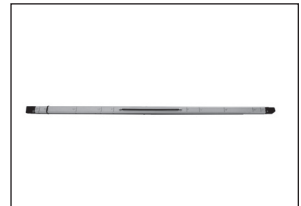

Figure 9

3. Insert shaft into the right end of the film core.
For film with poly-in (adhesive side is inside the web), make sure the adhesive side is facing upward. (Fig. 10)

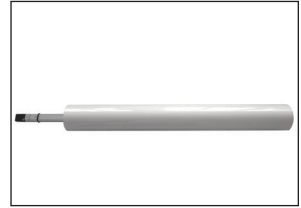

Figure 10

4. Carefully return the film shaft back into place.

▲ LOADING LOWER ROLL FILM

1. Repeat steps 1-4 to load the lower roll film.
2. Once the upper and lower film is on the shaft, Make sure the both films are align to the “O” ring.

NOTE: If the film is not aligned properly exposed adhesive will adhere to the rollers and may cause the film to jam.

▲ FILM THREADING

Refer to Figure 6.

8. MAINTENANCE

1. Do not apply any cleaning fluids to the rollers certain fluids may cause damage.
2. Do not clean rollers with sharp or pointed objects.
3. Use adhesive remover to clean resin off of the rollers.
4. Use a damp cloth with water to clean the body of the machine.
5. Store machine in a dry clean area.

9.TROUBLE SHOOTING GUIDE

Symptom	Cause	Possible Solution
Rollers do not operate after the RUN/STOP button is pressed	<ol style="list-style-type: none"> 1. Safety cover is opened 2. Power cord is not plugged in 3. Machine is not turned on 	<ol style="list-style-type: none"> 1. Check safety cover is properly closed 2. Plug in the power cord 3. Turn the machine on
Roller is not heating	Possible heating element, bimetal or thermal fuse malfunction	Call your authorized dealer
Poor Lamination	<ol style="list-style-type: none"> 1. Film tension is unbalanced 2. Wrong temperature/ speed setting 	<ol style="list-style-type: none"> 1. Adjust film tension 2. Follow manufacturers recommended temperature and speed

10. SPECIFICATIONS

MODEL		Alexis 27
Power supply		AC120V 60Hz
Power consumption		1450W
Max laminating width		685mm
Film thickness		25~75mic /1~3mil
Max laminating speed		2.5m/min
Ready time		10min
Heating method		Hot Roller
Driving motor		DC geared motor
Temperature control		Digital(micom)
Speed control		Digital(9 steps)
Transport type		4 Roller
Cross cutter		Yes
Hot lamination	Single	No
	Double	Yes
Reverse		Yes
Dimensions(WxDxH)		920x520x320mm
Unit weight		50kg

11. WARRANTY

Royal Sovereign International warrants the equipment sold is free from defects in material and workmanship for a period of One (1) year for Parts and Labor from the date of installation, excluding lamination rollers which are warranted for Six (6) months. This warranty is extended only to the original purchaser. This warranty is the only warranty made by Royal Sovereign International and cannot be modified or amended. Royal Sovereign's sole and exclusive liability and the customer's sole and exclusive remedy under this warranty shall be, at Royal Sovereign's option, to repair or replace any such defective part or product. These remedies are only available if Royal Sovereign's examination of the product discloses to Royal Sovereign's satisfaction that such defects actually exist and were not caused by misuse, neglect, attempt to repair, unauthorized alternation or modification, incorrect line voltage, fire, accident, flood or other hazard.

All warranty claims must be filed through the authorized Royal Sovereign dealer or reseller through which the equipment was originally purchased. Model, serial number and date of delivery are required for all claims.

The warranty made herein is in lieu of all other warranties, expressed or implied, including any warranty or merchantability or fitness for a particular purpose. Royal Sovereign will not be liable for personal damage or personal injury (unless primarily caused by its negligence), loss of profit, or other incidental or consequential damages arising out of the use or inability to use this equipment.

LIMITED WARRANTY

This warranty specifically does not cover damage to laminating rollers caused by knives, razor blades, or any sharp objects or abrasives, or failure caused by adhesives, or damage caused by lifting, tilting or improper use of the machine. Warranty repair or replacement by Royal Sovereign or its authorized Reseller(s) does not extend the warranty beyond the initial one year period from the date of installation. Unauthorized customer alterations will void this warranty.

CORPORATE HEADQUARTERS
Royal Sovereign International Inc.
2 Volvo Drive, Rockleigh, NJ 07647 U.S.A.
TEL: +1) 800-397-1025 FAX: +1) 201-750-1022
E-mail : info@royalsovereign.com

RS INTERNATIONAL CANADA INC.
191 Superior Blvd., Mississauga, ON L5T 2L6 CANADA
TEL: +1) 905-461-1095 FAX: +1) 905-461-1096
TF: +1) 866-961-6673
E-mail : info-ca@royalsovereign.ca