



SAFETY **T**ESTING **V**ALUE **A**SSURANCE

Scaffold • Shoring • Tube & Clamp • System

MANUFACTURING & SALES

SAFETY RULES and INSTRUCTIONS

For

STVA

MULTI-PURPOSE SCAFFOLD

INTERIOR or EXTERIOR



K) THE TIEING OF THE SCAFFOLD TO THE STRUCTURE IS OF GREAT IMPORTANCE TO the stability and safety of the scaffold. Assure that the structure to which the scaffold is tied or anchored is capable of safely supporting all loads imposed by the scaffold.

L) FREE STANDING SCAFFOLDS other than wall scaffolds must be restrained from tipping by guying or other means or otherwise stabilized as appropriate, recognizing that stability is essential to the safety of the scaffold.

M) INSTALL GUARDRAILS, MID-RAILS, AND TOEBOARDS at all openings, open sides and ends of every work platform when recommended or required

N) NEVER USE LADDERS OR MAKESHIFT DEVICES on tops of scaffold to increase the height. Never place

Comply with these regulations by plank on or stand on guardrails and mid-rails.

O) POWER LINES NEAR SCAFFOLDS ARE DANGEROUS. Use extreme caution and consult the power service company to have the lines de-energized, insulated or otherwise rendered safe. Never allow any Installation or use of scaffolds until this is done.

P) WHEN ANY CANTILEVERS ARE USED, such as brackets, etc., proper care and precautions must be taken to prevent tipping of the scaffold.

Q) FOR ROLLING SCAFFOLDS FOLLOW THESE ADDITIONAL SAFETY RULES:

QA) Never ride rolling scaffolds.

QB) Remove all materials and equipment From the scaffold before moving.

QC) Lock caster brakes at all times the scaffold is not being moved.

QD) Do not attempt to move rolling Scaffolds without sufficient help and roll On level surfaces only. Watch out for holes or floor obstructions and for overhead obstructions, including power Lines, energized craneways, and other Hazards.

QE) The maximum platform height of a rolling scaffold must not exceed four(4) times the narrowest dimension. Check local state/OSHA Regulations for other height/base limitations such as 3:1 in CA, OH, OR, MT and ME; 3.5:1 in WA. appropriately widening and /or lengthening the scaffold at the lower levels so that the above proportions are not exceeded. If the base dimensions cannot be increased, extreme care must be taken to secure the scaffold from tipping; it must be guyed, or tied to a solid structure and maintained in a stabilized condition at all times so that it cannot tip over while supporting persons while being moved or while being erected or dismantled.

QF) Apply pulling or pushing forces at the bottom frames and as close to the scaffold base as possible. Never attempt to move scaffold from on top.

QG) If rolling scaffolds are used outdoors, Care must be taken to assure that they cannot become unstable due to wind or other conditions.

QH) DO NOT OVERLOAD SCAFFOLDS Refer to and do not exceed the scaffold load capacities

SAFETY RULES and INSTRUCTIONS For MULTI-PURPOSE SCAFFOLD INTERIOR or EXTERIOR





WARNING



Improper erection, dismantling or use of Multi-Purpose Scaffold may result in serious injury or death!! Erectors/dismantlers and users of Multi-Purpose Scaffold must read and fully understand these Safety Rules & Instructions as well as all federal OSHA, state, and local regulations pertaining to this equipment prior to use.

LOAD CAPACITIES

6'3" Length Unit-750 Lbs.(WORKERS & MATERIALS)

WARNING! DO NOT OVERLOAD SCAFFOLD, MAY RESULT IN SERIOUS INJURY!

ITEM SPECIFICATIONS

6' Long Multi-Purpose	overall Length	Overall width	Overall Height	Folded Length	Highest Standing Level	Overall Weight	Thickness
6' Long Multi-Purpose Scaffold	73-3/4"	28.94"	78.27"	N/A	IV"	173.36Lbs	0.135"
	187.325 cm	73.5cm	198.8cm		180.34cm	78.8kg	0.3429cm
	1873.25 mm	735mm	1988mm		1803.4mm		3.429mm

ASSEMBLY INSTRUCTIONS

For proper assembly, your Multi-Purpose Scaffold must be comprised of 13 individual parts. (As Drawing)

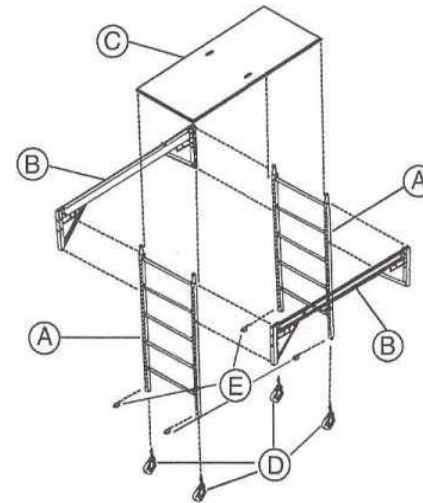
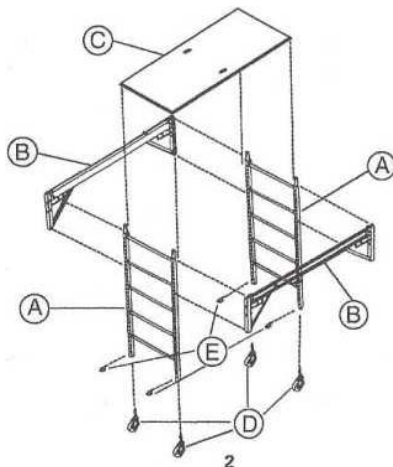

Parts List

No.	Part Name	QTY
A	Frame	2
B	Side Brace	2
C	Platform	1
D	Caster	4
E	Lock Pin	4

Step 1. Attach side brace B to two frames A:

- Pull U-shape lock pin at each end of side brace to the disengaged position. (SEE EXHIBIT A)
- While holding U-shape pin in disengaged position, place U-channel on each end of side brace B around leg of frame A at desired platform height.
- Release lock pin and be sure that pin fully engages into hole in frame A leg.

Step 2. Attach second brace B to both frames A (REPEAT INSTRUCTIONS IN STEP1)

EXHIBIT A

⚠ WARNING ⚠

Both side braces must be positioned at the same height on the frames so that the platform will be level.

Be sure all 4 U-shape lock pins are fully engaged in holes of frames.

Be sure all 4 U-shape lock pins are in the locked position.

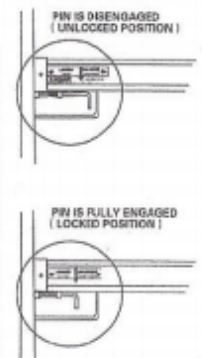

DISMANTLING NOTES

The work of dismantling scaffolding should be under the supervision of an individual with proper experience and aptitude (competent person). The following should be observed while dismantling.

1. It shall be the responsibility of employees to read and comply with the following common sense guidelines which are designed to promote safety in the dismantling of scaffolding.

2. Check to see if scaffold has been structurally altered in any way which would make it unsafe; and, if so, reconstruct where necessary before commencing with the dismantling procedures.

3. Dismantle scaffold from the top down. Begin by removing all accessories from that section being dismantled at the time.

4. On stacked scaffolds do not remove ties and braces until dismantling has reached the section to which they are attached.

5. Always work within the inside of the scaffolding.

6. When moving up or down the scaffold do NOT climb on ties, braces or unbraced components. Climb over the top of the frame. Do not swing around outside of the frame.

7. Be sure that area below is clear of personnel not involved in the dismantling and is secured against unauthorized access.

8. Lower scaffold components in a safe manner as they are dismantled. Avoid dropping or throwing the components as this could result in injury to personnel below, or damage to the equipment.

9. Use energy absorbing lanyards and full body harness when feasible

Step 3. Install platform C on side braces B so that the platform is fully seated within inner channel on top of side braces.

Step 4. Rotate the platform clips into the engaged position.

Step 5. Install 4 casters D into legs of frame A and pin with lock pins E.

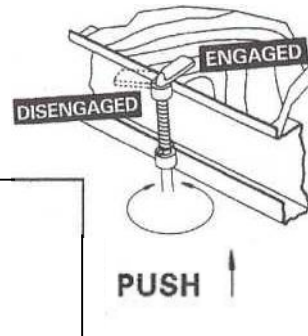

AWARNINGA

Recheck all side brace lock pins for full engagement before accessing platform.

Recheck platform to be sure it is properly seated within side brace channel and the platform clips are fully engaged before accessing.

When accessing platform, climb over top of frame ladder~DO NOT swing around side of frame.

SOME TYPICAL APPLICATIONS INCLUDE:

- Painting
- Acoustical/ Ceilings
- Drywall Installation & Taping
- Window Cleaning & Treatment Installation
- Sign Installation & Maintenance
- Overhead Door Installation
- Lighting & Wire Maintenance & Electrica
- General Building Maintenance
- HVAC Installation
- Functions as Shelving
- And Much More

SCAFFOLDING SAFETY RULES

SERIOUS INJURY OR DEATH MAY RESULT FROM IMPROPER ERECTION OR USE of scaffolding equipment. Erectors and users must be familiar with and follow safe practice and the Safety Rules contained herein. These Safety Rules cover generalized situations only and should not be used to replace any other additional safety and precautionary measures that may be necessary to cover the many usual or unusual conditions encountered during installation or dismantling. The Rules are not intended to conflict with, or supersede the requirements of OSHA or any other governmental regulations, codes and ordinances; the user must refer to and comply with all such specific provisions of law.

A) FOLLOW SAFE PRACTICE OF THE SAFETY RULES AND COMPLY WITH OSHA and all other federal, state and local regulations, codes and ordinances pertaining to scaffolding during any use of the equipment

B) THE POTENTIALLY HAZARDOUS NATURE OF SCAFFOLDING ERECTION WORK makes it important that all personnel assigned to this work be instructed in these Safety Rules, safe practices and procedures and be under the supervision of an experienced and knowledgeable person. Assure that these Safety Rules are posted and that all persons erecting and using the scaffold are aware of and follow them.

C) REPORT ANY UNSAFE CONDITIONS TO SUPERVISORS, Do not work or allow persons to work on scaffolds when sick or suffering from dizziness, unsteadiness or other physical symptoms which could affect their ability to work safely

D) INSPECT ALL EQUIPMENT BEFORE USING. Never use any equipment which is damaged, defective or deteriorated in any way.

E) INSPECT ERECTED SCAFFOLD FREQUENTLY and be sure that they are maintained in safe condition, that scaffold connections have not become loosened and that components have not been improperly released or

removed.

F) MAINTAIN ALL EQUIPMENT IN GOOD REPAIR. Never use corroded or excessively rusted equipment; the strength of such equipment is not known.

G) CONSULT YOUR SCAFFOLDING SUPPLIER WHEN IN DOUBT. NEVER TAKE CHANCES.

H) ALWAYS READ THESE SAFETY RULES in conjunction with the safety packet

I) ALWAYS SUPPORT SCAFFOLDS FROM A SOUND, STABLE SURFACE and assure that it is adequate to support the intended scaffold loads. Never support scaffolds on unstable, loose objects which could tip, break or become dislodged.

J) LIFT AND LOWER COMPONENTS CAREFULLY AND SAFELY; use tag lines when appropriate to the handling method. Never allow excessive quantities of components to be stockpiled on partially complete scaffolds. Stock only sufficient components consistent with the progress of the work. Lower dismantled components as soon as possible. Never drop components deliberately.