

**0-4-0 B4 Locomotive**  
O Gauge Model

**Owner's Manual**

***dapol***

*Authentic Scale Model*

## Contents

A history of the Adams B4.....	3
Model specifications / Quick Start .....	4
Unboxing .....	5
Operation .....	6
Maintenance .....	7
Fitting accessory items / Installing DCC decoder ....	8
Speaker installation.....	10
DCC & DCC Sound factory fitted models, including sound function keys .....	11
Automatic sounds / Cab roof removal .....	13
Real Drive .....	14
Spare parts .....	16
Manufacturer warranty.....	18
Contact information .....	22
Notes .....	23

*Thank you for purchasing this Dapol product. We hope it gives you many years of enjoyment*

## **A history of the Adams B4**

In 1890 Adams ordered 20 powerful four-coupled tank engines from Nine Elms Works, the design being preferred to six-coupled because of the many poorly laid out goods yards and sharply curved Cattewater and Sutton Harbour lines at Plymouth.

When the South Western gained control of Southampton docks in 1892, Adams transferred two engines there, which had their cab front and back sheets cut away to aid visibility and were named JERSEY and GUERNSEY. Over the next few years twelve more were transferred to the docks, including two of the five built by Drummond.

All 25 engines were taken into B.R. stock in January 1948; however, fourteen were withdrawn over the next year, leaving just eleven survivors, distributed to Eastleigh, Plymouth, Bournemouth and Ashford.

The last two representatives stationed at Winchester were withdrawn in October 1963, a month short of their seventieth birthday. Happily, both have been preserved.

## Model Specification

- Diecast metal chassis
- Diecast wheels, motion and connecting rods
- Rocking front axle for perfect running
- Sprung buffers
- All wheel pick up with brass bearings
- Two chimney variants
- Removable cab roof with magnets for easy crew installation
- Linseed filtrator where appropriate
- Gearbox for low-speed performance
- DCC Ready (21 Pin)
- 'Toolless' DCC decoder and speaker fitting
- Diecast footplate
- Body detailed to authentically represent operating number and its operating period
- Highly detailed cab interior
- Firebox flicker effect
- Accessory bag
- Sound fitted models available

**Read this section before you go any further!**

**Quick start:** *We know you would like to have your model running as quickly as possible; please spare a moment to read this section first.*

- An accessory pack containing a front vacuum pipe and PCB tool is supplied.
- Models fitted with optional DCC or DCC sound will operate on DC or DCC\*

\*When operating on DC, the sound fitted model will produce exhaust sounds automatically.

### Icons used in this manual



**Information**

Hints and tips



**Caution**

Take care when performing this step



**Warning**

A risk of damage may exist

## Unboxing

- 1) Carefully remove the model whilst attached to its acrylic plinth from the foam insert.
- 2) Remove the two screws securing the locomotive to the acrylic plinth. Ensure the locomotive is suitably cradled while removing screws to avoid damage.

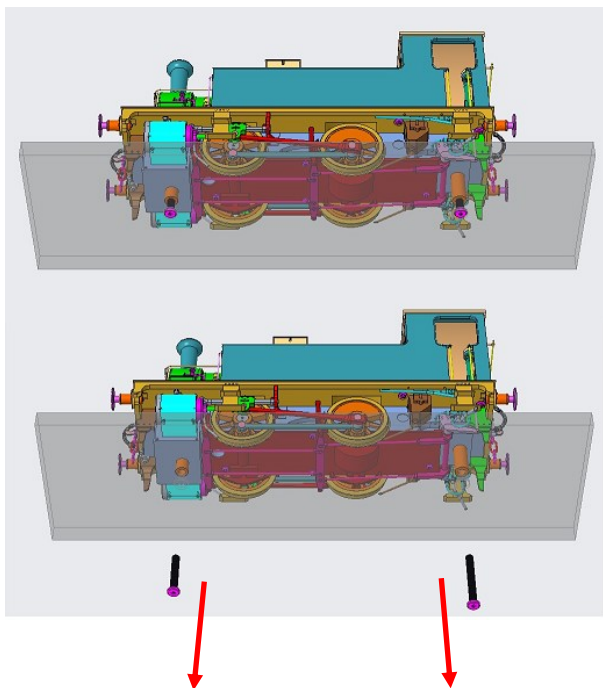

**An accessory pack** is supplied with your model containing the following items: (See fitting of accessory items for further detail)

- 1 x Front vacuum pipe
- 1 x Smokebox door / PCB tool
- DC Blanking PCB (If Sound or DCC fitted)

## Operation

Running in / First use: No special running in or initial lubrication is required; our 'new generation' locomotives have been designed with care to offer many years of service with minimal maintenance

**i** Before operating your model, first run in both directions at a low-speed checking for correct operation using either DC or DCC power source

**i** A DCC-fitted or DCC sound-fitted model will 'autodetect' and operate on both analogue (DC) and DCC layouts.

**i** DCC address is factory set to address #3. The sound decoder fitted is a Zimo or a Dapol imperium for DCC fitted versions.

If operating a DCC fitted model on DC, please follow the DC operating procedure for your decoder.

**!** **Caution:** A Non-DCC fitted model will not operate on a DCC controlled track.

## Maintenance

The model uses components which require little maintenance. We suggest that the drive train and gear box are lubricated after every 100 hours running using a light synthetic lubricating oil such as Dapoil.

**Warning:** Mineral oil types or thicker oils may damage your locomotive paint finish or components and invalidate your warranty.

**i** Remove any surplus or spilt oil immediately using a lint free cloth.

**i** Regularly check your model for build-up of dust or loose scenic material around moving parts.

**Caution:** Do not over oil. Over oiling may damage paint finishes and/or cause build-up of dust.

- Lubrication can be applied to axle bearings and connecting rods without removing covers. Use only 1 small drop of oil on each point.
- To lubricate the worm gear, there is no need to remove the brake rodding. Remove the 6 keeper plate cover screws (shown below).
- Place 1 or 2 drops of oil on the large rear gear, this will migrate through the gear train to the worm during operation.

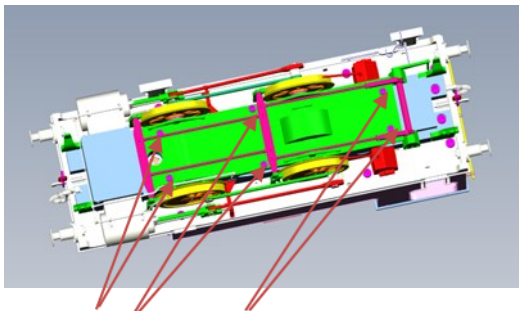

Remove these 6 screws and then the keeper plate

## Fitting of accessory items:

A front vacuum pipe is included in the bag. This is not fitted as it may restrict the opening of the smoke box door. Once your model is specified to your choosing, then this may be fitted as the drawing below illustrates. We recommend the use of a non-permanent adhesive as this will simplify removal at some future date if access to the PCB is required.

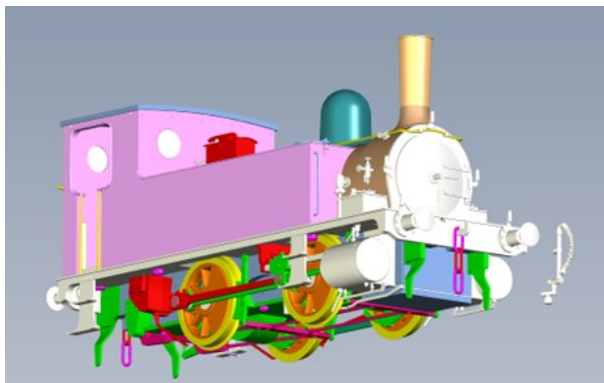

All other accessories are factory fitted to the model.

## Installing a DCC decoder (DCC Ready)

Dapol recommend a Dapol Imperium 21 pin decoder. The decoder chosen must offer a minimum of 2 functions in order for the firebox flicker to operate. (This is controlled by the AUX 1 output of the decoder).

The model is fitted with Dapol's tool-less DCC and speaker fitting system. To install a decoder and/or optional speakers (2) follow these steps:

- 1) The smokebox door is hinged and can be opened by gently pulling on the smoke box dart (Carefully!).



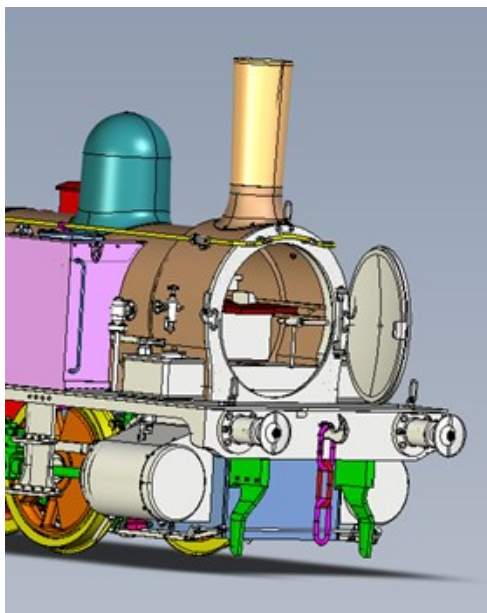

- 2) Use the 'hook' end of the smokebox tool to engage with the hole in the PCB and pull out the PCB.

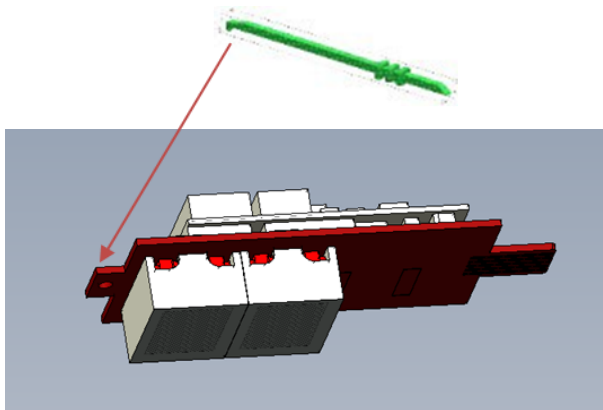

- 3) When the PCB is fully removed from the smokebox the decoder blanking plate can be removed in the usual way and replaced with the decoder of your choice

## Speaker Installation

If using a sound decoder two **8-ohm** 'Sugar cube' type speakers should be installed. If an alternative type is fitted, it must produce a total impedance suitable for your decoder's amplifier.

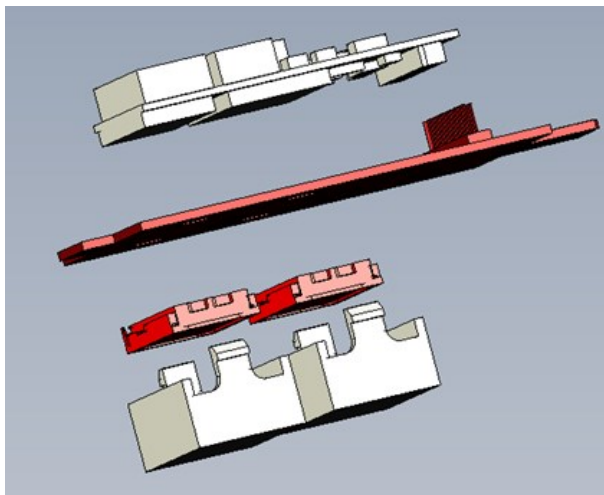

- 1) The speaker enclosures are removed by un-clipping (They are each held by 2 clips).
- 2) Drop the sugarcube speaker into the enclosure with the speaker contacts uppermost and orientated to match the location of the silver contact areas on the underside of the PCB (they are on the right as viewed from the cab looking towards the front of the locomotive).
- 3) Clip the speaker enclosures back in place on the PCB
- 4) Slide the PCB into the locomotive, with the speaker on the lower side. Follow the guide rails on the inside of the smoke box. There should be a tangible click as it seats into position
- 5) Finally, close the hinged smoke box door

## DCC Factory Fitted models

Factory fitted models are fitted with an imperium DCC decoder (address 3) to control the locomotive. The following function keys on your controller operates special functions.

**F1** Firebox flicker On/Off

## DCC Sound Factory Fitted models

This model is pre-fitted with a Zimo sound decoder and sugar cube speakers in the smoke-box. Manual sounds are operated by the following keys on your DCC controller.

**i** When operating your locomotive on a DC (analogue) layout the decoder will autodetect the power source and produce a synchronised exhaust sound.

### Function key summary (Manual sounds):

**F1 Sound fade in/out:** Useful when loco is going 'on or off scene' or into / out of a tunnel.

**F2 Short whistle**

**F3 Long and short whistle**

**F4 Coal shovelling:** The sound of the firebox door being opened is heard, followed by the firebox flicker effect operating. During this time the sound of shovelling coal will be heard.

When F4 is turned off, the shovelling will stop and the firebox door will be heard to close, as the same time as the flicker extinguishes

**F5 Injector on/off:** The injector is used when topping up the water level of the boiler.

**F6 Steam ejector on/off:** Used for creation of a vacuum and for blastpipe draught creation.

**F7 Brake application/release:** When first pressed the sound of a brake application will be heard, when pressed again (turned off) the sound of the brakes being released will be heard.

**F8 Flange squeal on/off** This is only heard when the model is in motion.

**F9 Light engine mode:** with F9 ON lighter chuffs will be heard and the locomotive will accelerate and decelerate more readily.

CV390 can be adjusted to change this 'inertia' effect. (Factory value 140).

**F10 Safety valve 'blow off'**

**F11 'More steam'** sequence: Injector sound with coal shovelling sound.

**F12 Manual draincocks:** Additional to the automatic draincocks, F12 enables the sound of steam 'blast' from the cylinder drains to be triggered.

**F13 Buffering up:** Sound of buffers clashing. This can be 'preselected' whilst the loco is moving so that the sound is heard the instant the loco stops

**F14 Coach door slam**

**F15 Guards whistle**

## **Automatic sounds:**

### **Brake squeal:**

This sound will be produced when the locomotive speed drops below a pre-set value, and only whilst the locomotive is decelerating. The threshold value can be set using CV 287 and can be increased or decreased from the factory value of 20.

### **Chuff intensities:**

The locomotive can produce 3 intensities of exhaust 'chuff'. Heavy chuffs will be heard whilst accelerating, lighter ones when the target speed is reached. Upon deceleration, no chuffs will be heard.

With F9 ON, even lighter chuffs will be produced, with more 'cut-off'.

### **Cab roof removal**

The cab roof is held in position by magnets and can be easily removed if required for ease of crew fitting.



Body removal is not required for DCC decoder or speaker installation.



**Caution:** Dapol do not recommend disassembly, care should be taken to avoid damage to delicate assemblies and detail parts

## **'Realdrive'**

A basic driving function is enabled by default. An advanced operation ('Realdrive') is possible which adds coasting and a working brake. This allows operation in a more prototypical manner. Brake applications will be needed to bring the model to a stop – closing the throttle results in the model coasting.

These two features are added to the 'light engine' feature that remains active with or without the 'RealDrive' feature.

**i** If you are new to 'RealDrive' Dapol recommend testing on a clear track, preferably a loop.

To activate 'RealDrive' set CV4 to 254, and CV309 to 7.

To de-activate 'RealDrive' set CV4 to 27 and CV309 to 0. (These are the factory settings)

Driving technique: As the regulator is closed (speed step 0) the model will continue to coast for a considerable distance, slowing gradually.

Applying the brake using F7 will bring the locomotive to a stop. The braking rate can be adjusted by changing CV 349 (High values lessen the braking effect).

### **Points to consider**

When F7 is ON the brake is ON. When F7 is OFF, the brake is OFF

**i** Set F7 on your DCC system to 'momentary' to make a brake application with a single press.

The regulator must be closed for the brake to take effect.

Braking intensity is altered via CV349. (factory setting is 27)

Sharper brakes (low values in CV349), allow multiple short applications.

A gentle brake (higher values in CV349) will allow a single application of the brake to bring the model to a halt.

**i** Whilst the brake (F7) is ON, the model will not accelerate. If stationary and the regulator is opened with the brake ON, the model will not move.

**i** To simulate heavier chuffs (e.g. whilst the model is climbing), put the brake(F7) 'ON' and open the regulator by at least one speed step. This will initiate heavier chuffs until the regulator is reduced OR the brake is turned off.

**i** To use the regulator only to bring the model to a halt, the brake is turned on first and the speed reduced as required. Speed will then reduce at the pre-set braking rate.

**i** To operate a consist using 'RealDrive' and avoid difficulties, all locomotives consisted must have 'RealDrive' activated. Equally all models must have 'Realdrive'

## Spare parts

A range of spare parts is available for this model on launch. For a full list please and availability refer to the Dapol website but will include

<b>Name of part</b>	<b>Reference number</b>
Cab roof	D1705-K02
Chimney	Adams
Chimney	Drummond
Whistle	D1705-H10
Smoke box dart	D1705-H02
Buffer assy.	Small head
Buffer assy.	Large head
Rear Handrail	Set with handles
Vacuum pipe front	D1705-J03
Vacuum pipe rear	D1705-J04
Rear lamp iron-set	D1705-K08
Front lamp iron-set	D1705-L06
Coupling hook & links	D1705-F06
Sand box - LEFT	D1705-E13
Sand box - RIGHT	D1705-E12
Guard iron - Left front	D1705-E06
Guard iron - Right front	D1705-E07
Guard iron - Left rear	D1705-E16
Guard iron - Right rear	D1705-E17
Rod screw-1	Screw 1
Rod screw-2	Screw 2
Brake pull rods	D1705-H01
Control rod left	D1705-H07
Control pull rod	D1705-H09
Control rod left	D1705-H08
Keeper plate	D1705-E01
Coupling rod	D1705-F06



<b>Name of part</b>	<b>Reference number</b>
Connecting rod	D1705-F04
Cab door handle	D1705-K12
Slide in PCB	PCB
Motor with worm & flywheel	300-E00
Worm gear	D1705-M05
Dome per colour	D1705-K03
Driving wheel set -black	D1705-F01
Driving wheel set -green	D1705-F01
Driving wheel set c/w gear black	D1705-F01
Driving wheel set c/w gear green	D1705-F01

## Manufacturer's warranty

**Description:** We want you to be completely satisfied with your purchase and obtain many years of pleasure from its operation. If you experience any problems with your model, we suggest that your first point of contact is your retailer; they will be able to advise on any teething problems and will use their experience to quickly solve many of your questions or concerns.

Your dealer is also the fastest way to exchange a model which is found to be missing components, accessories, or is otherwise defective after purchase. But we recognise that you may require more: If a replacement model is not available you may find a refund disappointing, or you may simply prefer to deal directly with Dapol. For these reasons, we offer a 12-month manufacturer's repair warranty on this product in addition to your statutory rights.

**i** Our Manufacturer's warranty in simple terms: If your model experiences a mechanical or electrical fault within one year of purchase, other than returning to the place of purchase, we offer you have the option of a free repair at our service agents which is (within the UK) also post free.

2nd year service (locomotives only). An option exists to have your locomotive serviced by our authorised agent (a service fee is payable). Simply contact our agent and you will be advised of the current cost and given a freepost address. The model will be serviced and returned with a validated warranty certificate for a second year of no-quibble warranty for your model.

**i** **Please note:** Year 2 warranties cannot be issued more than 13 months after the original date of purchase.



**VERY IMPORTANT:** Please ensure that your dealer has supplied a proper printed receipt with your purchase. Without this, our service agents are unable to offer warranty service. Repairs will be charged at the prevailing rate. Your statutory rights with the place of purchase are unaffected.

## How to claim

Locate the proof of purchase (copies acceptable)  
Year 2 claims: Return with validated 2nd year certificate (or service fee if within 13 months of purchase).

Contact our service agent for a Job ID number. Write the Job ID number on the outside of the package, and enclose your name, contact information, proof of purchase and if applicable your year 2 certificate.

When posting, ensure that you obtain proof of posting and the model is adequately packed. If you require proof of delivery or insurance, you will need to purchase the additional service (at your cost) from your post office.

What happens next? If you have supplied an email address, receipt will be acknowledged, you will be advised when work commences and is completed. They will contact you in case of unforeseen difficulties during repair. Using your email address, you can use the online enquiry system to check the status of your model at any time via the internet.

If you have not supplied an email address, your model will be repaired and returned, you will only be contacted in case of a problem. You may of course contact our agent (quoting the job ID) at any time. What happens when the warranty expires? Our service agent offers a comprehensive repair service at reasonable cost.

Alternatively, a comprehensive range of spare parts is available for purchase.

### **The small print! (Terms and conditions)**

We intend this 'No Quibble' warranty to be a simple and fair addition to your statutory rights, however, some situations simply cannot be covered as they are outside of our control. We've listed these below.

**i** We're reasonable folks, so if in doubt, please contact either our customer service or service agents for advice on your situation and we'll suggest the best course of action.

### **Terms and conditions**

- 1) Only Dapol models packaged with this warranty or marked with a 'W' are covered under this scheme.
- 2) This manufacturer's warranty is in addition to your existing statutory rights and offers a repair service for your model. Requests for outright refund or replacement should be directed to the place of purchase.
- 3) In the event the model cannot be repaired, at Dapol's sole option, you may be offered: a new replacement model (subject to availability), a refund voucher (for exchange at the place of purchase) or the return of the model in an unrepaired condition.
- 4) On issuance of a replacement model or refund voucher the original model and all associated accessories shall become the property of Dapol Ltd.
- 5) The replacement or repair of a model shall not extend the original warranty period under any circumstance.
- 6) This warranty covers the model's electronics, chassis and mechanisms for manufacturing defect or premature failure. The following situations are not covered by this warranty:

- a) Accidental damage
- b) Missing accessories (i.e. accessory packs) – Please return to your dealer.
- c) Over or under oiling, incorrect oil type (use a thin synthetic oil i.e. Dapol, LocoLube™ or similar)
- d) Fair wear and tear (unless deemed to be premature by Dapol or our service agent)
- e) Routine maintenance and/or faults due to presence of foreign bodies i.e. Replacement drive tyres, Dirty wheels, Pickups etc.
- f) Mishandling: Inclusive of broken wires, dislocated driveshaft's, damaged valve gear. Broken detail parts.
- g) Mechanical or electrical modification; inclusive of fitting of DCC to a non DCC ready model. (Reasonable modifications inclusive of: Weathering, super detailing etc. are permitted, however any adverse effects of such modification shall invalidate the warranty.)
- h) Unauthorised attempts to repair or modify the model.
- 7) This warranty is not transferable and is valid only for purchases made from authorised Dapol dealers when accompanied by a proof of purchase.
- 8) This warranty does not cover: Used models, models purchased from private individuals or auction sites (unless a 'Buy It Now' purchase of a new model from an authorised dealer when supplied with supporting proof of purchase).
- 9) Dapol and its agents shall be the sole arbiters as to the warranty status of the model and their decision is final.
- 10) Whilst every effort will be made to protect such, Dapol and its agents shall not be liable for damage or alteration to any 'super detailing' or other aftermarket cosmetic, mechanical or electrical enhancements.
- 11) Dapol and its agents shall not be held liable for damage caused to inadequately packaged models.

- 12) Dapol and its agents shall not be held liable for models lost in the post unless a proof of posting can be supplied.
- 13) All repairs will be repaired on a first in-first out basis, within a reasonable period after receipt by our agent. Unless agreed in writing by Dapol or its agent prior to receipt of the model time shall not be of the essence in any contract.
- 14) All repairs and/or replacements are subject to availability

### **Contact Information**

#### **Dapol Customer Service**

Telephone: 01691 774455

E-Mail [sales@dapol.co.uk](mailto:sales@dapol.co.uk)

Website [www.dapol.co.uk](http://www.dapol.co.uk)

#### **Service Centre**

DCC Supplies Ltd

Telephone: 01905 621999

Email: [dapol@dccsupplies.com](mailto:dapol@dccsupplies.com)

Website [dapol-spares.dccsupplies.com](http://dapol-spares.dccsupplies.com)

## NOTES:

This page is left blank to write your own notes

**Dapol Limited**

**Unit 7 Gledrid Industrial Park, chirk,  
Wrexham, LL14 5DG**

**Telephone: 01691 774455**

**Website: [www.dapol.co.uk](http://www.dapol.co.uk)**

**Email: [sales@dapol.co.uk](mailto:sales@dapol.co.uk)**

**Spares: [dapolspares.dccsupplies.com](http://dapolspares.dccsupplies.com)**