



Class 27

IMPORTANT INSTRUCTIONS

Please read **BEFORE** using this model

THIS MODEL NEEDS OILING BEFORE USE:

Whilst this model has been pre-lubricated at manufacture, the factory applied lubrication may have dried out during transit or storage. Therefore please lubricate the visible gears on the underside and test run before use using a proprietary lubrication. Your local model shop will be able to advise you in this, however Dapol also sell recommended locomotive oil.

If under test your locomotive is sluggish, or excessively noisy (remembering with proper lubrication and running in it will quieten down considerably), then you may wish to lubricate the worms and their associated bearings. This can easily be done by unclipping the bogie from the chassis as shown in the accompanying diagram.

Please remember to run your locomotive in for 30 minutes in each direction after lubrication, and the failure to lubricate your locomotive will result in a voided warranty.

POWER TYPES (DCC) and OPERATION

IMPORTANT NOTES:

Failure to oil may affect any warranty claim. Please use caution when applying oil as some types can cause damage to plastic. If oil touches the body then immediately wipe off using a non-fluffy cloth. No part of the motor requires lubrication. **DO NOT OIL THE MOTOR OR POLES / ARMATURE.** Do not operate the model on track laid onto carpet as the dust and fibres will impare the mechanism.

POWER TYPES (DC) and OPERATION:

If you wish to run the model on standard DC - then do nothing. Our PCB will automatically recognise you have a DC controller and will allow operation at normal DC requirements. * **PLEASE NOTE:** When using standard 12v DC power, it is important that you use an appropriate 'N' gauge controller as '00' controllers (both new and old) may not allow the measure of control required for our super-fine 'N' motors.

POWER TYPES (DCC) and OPERATION:

Our model is fully DCC Ready. The unit is fitted with a DCC board which features a 6-pin NEM socket pre-fitted with a DC 'Blanking Plug'. The body simply pulls away from the chassis and the PCB can be seen on top of the chassis block (see diagram overleaf).

Carefully pull out the 'Blanking Plug' and fit the decoder of your choice.

WARRANTY: Dapol Ltd will remedy any defect or malfunction occurring with the locomotive during a period of six months from the date of purchase. This guarantee does not extend to defects or malfunctions caused by damage or unreasonable use, including failure to provide correct lubrication. If for any reason the model develops any fault within the warranty period, please return to the **Place of Purchase** with your **Proof of Purchase** (till receipt / credit card slip etc). Do **NOT** return it to Dapol Ltd. The seller will then return it to Dapol Ltd under their agreed returns policy.

Without a suitable proof of purchase Dapol Ltd cannot guarantee to offer any warranty service.

The Dapol warranty is given in addition to all legal rights of the purchaser under the 'Sale of Goods Act' and shall expire six months from the date of purchase. Dapol Ltd shall not be responsible for any consequential loss or damages arising in regard to any Dapol Ltd product.

EUROPEAN REGULATIONS: Dapol products conform to WEEE and RoHS requirements. If you have a need to dispose of any electrical part, please do so correctly.



Oiling points for gears before test running, and removal of body for DCC installation

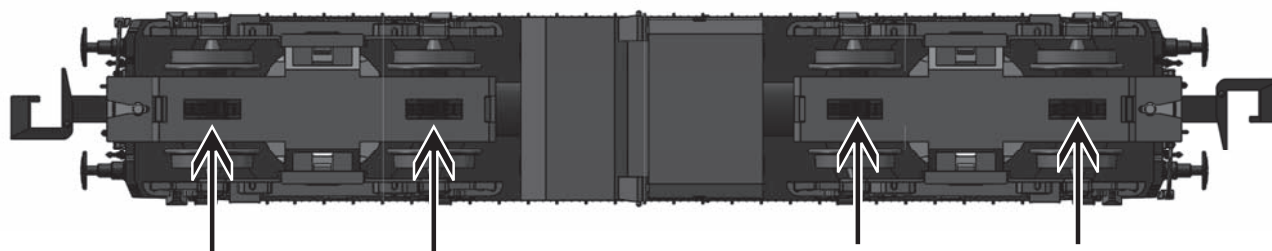

Normal oiling points into exposed gears without removing body

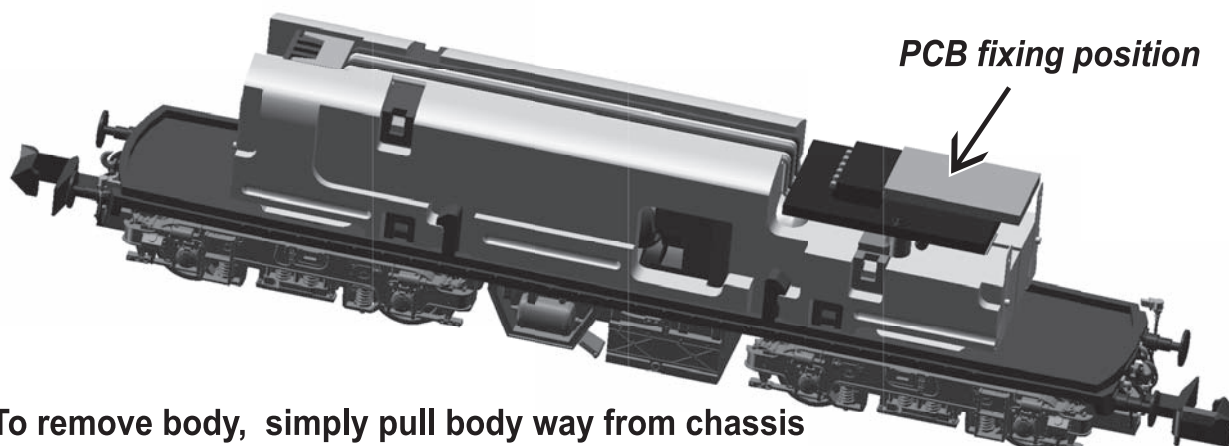

To remove body, simply pull body way from chassis to leave exposed chassis as image.

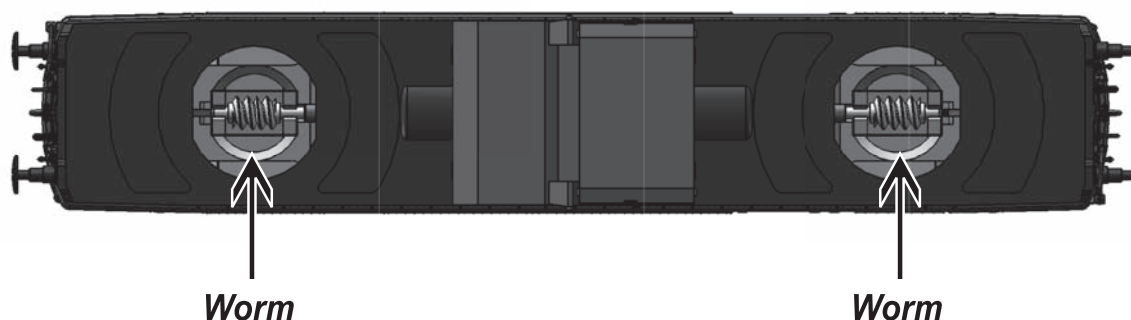

To expose drive worms and chassis for routine maintenance, simply pull the complete bogie assembly away from the chassis. The bogies are a 'pull-out' & 'push-in' fitting method. When refitting, ensure that the gear on top of the bogie tower meshes with the worm.



Class 27 Locomotive

IMPORTANT INSTRUCTIONS

Please read **BEFORE** using this model

UNPACKING & HANDLING YOUR LOCOMOTIVE:

Your model contains delicate precision parts. Please handle accordingly.

Removing your model from its case: Remove the model from the plastic case along with its foam packing. The model can then be removed from the foam above a soft surface to prevent damage if dropped.

- Take care to ensure that detail parts do not catch on the foam as the model is removed.
- Do not use the Buffers or other parts as handles or levers when removing the model from its packaging.

YOUR MODEL NEEDS LIGHT LUBRICATION AFTER EVERY 50 HOURS RUNNING:

This model has been factory lubricated and requires no initial lubrication. Maintenance requires an extremely light application of plastic safe * oil, such as Dapoil or Locolube after every 50 hours of running (Storage in hot environments may require more frequent applications). Please be aware that over-oiling the wheel bearings will interfere with the electrical pickup of your model. Therefore, we recommend you use a very fine artist's paintbrush to apply only the tiniest amount of lubricating oil precisely between the bearing surfaces, as follows:

- Place a droplet of plastic safe oil onto a hard, non-absorbent, surface;
- Use a very fine pointed paintbrush to transfer a very small amount of oil, precisely, onto the bearings at the points indicated in the diagram overleaf. (The oil should not be painted on but, rather, capillary action should be used to draw the tiniest amount of oil out of the tip of the brush into the bearing.)
- Dry the paintbrush by blotting with absorbent paper, such as kitchen towel;
- Re-apply the dry paintbrush onto the oiled bearing, to 'wick away' any excess oil. Repeat steps 3 and 4 until the only remaining oil is an extremely fine (almost invisible) coating at the precise point where the two components rub together.

Please keep oils and lubricants away from the Motor and electronic circuitry located inside the body. The motor is of advanced self-lubrication design, 'sealed-for-life', and lubricants may damage the delicate circuitry. Also, be aware that N gauge track should never be laid directly onto carpet, as dust and fibres will become entangled in your locomotive's finely detailed mechanisms.

*Your model supplier can advise on the best 'plastic safe' oils and lubricants available in your country.

RUNNING IN' YOUR LOCOMOTIVE:

You will obtain quieter and smoother performance from your Dapol locomotive if you invest a little time 'running in' the motor and the motion parts. We recommend that you begin the 'running in' period by operating the locomotive on its own, at a moderate speed, for a period of at least half an hour in each direction. (The complete 'settling in' process often continues beyond the initial 'running in' period, and you will notice that the locomotive gradually runs quieter and smoother over several weeks of normal coach/wagon hauling operation.)

WARRANTY:

Please refer to separately provided warranty paperwork for details.

Accessory parts:

Additional detail parts are supplied in plastic bags within the outer case & fitted as follows:

- Couplings can be removed or supplied alternatives fitted by simply pulling the existing Rapido type away from the locomotive. Alternatives simply push fit.

Please note that the following parts may interfere if a coupling is fitted.

- **Snow plough:** Remove the coupling and centre part of the NEM pocket. Clip the plough into the slot of the NEM pocket.
- **Pipes:** Are fitted in the order shown and push into matching openings in the buffer beam. If desired a small spot of adhesive can be used to secure.
- **Dummy Screw Coupling:** This is clipped into the hook already placed on the buffer beam.

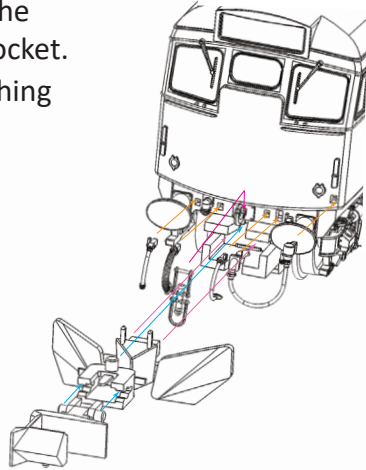

DC OPERATION:

If you wish to run the model on standard DC – then do nothing. Our PCB will automatically recognise that you have DC controller and will allow operation at normal DC parameters. **Important Note:** This model should only be used with a DC controller designed for model railways rated at 12V DC nominal voltage. When (optionally) fitted with an appropriate DCC decoder it may also be used with a compatible DCC control system. You can turn the rear light off by pulling the DIP switch to the 'OFF' position.

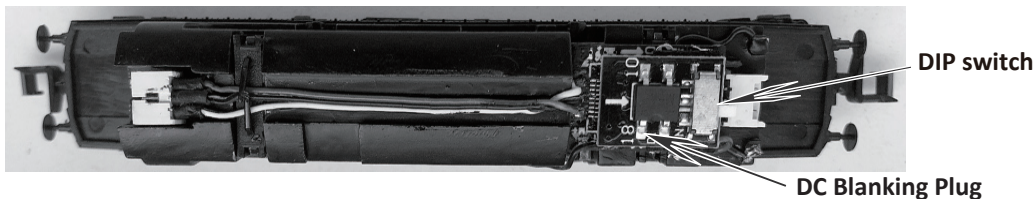

DCC OPERATION:

Our model is fully DCC ready. The model is fitted with a DCC board which features a Next 18 plug pre-fitted with a 'blanking plug'. Carefully remove the blanking plug and insert the decoder of your choice. Before converting to DCC please ensure that your decoder will fit the model, as some decoders are large and could have a thick protective outer shroud. To expose the PCB, simply pull the body away from the chassis using finger pressure. Fit your decoder and programme as normal. Reclip the body.

We have designed this model to have independent control of front and rear lamps. For best operation, we recommend a 4 function (or greater) decoder is fitted (for example a 6 function Dapol Imperium Next-18) to your model. If you have purchased the Dapol factory fitted decoder it has been fitted with a pre-programmed Imperium decoder (Please refer to separate DCC operation instructions supplied). If fitting a decoder (including a non-factory fitted Imperium) you will need to consult the decoder manual to correctly configure the decoder for operation of the locomotive lighting.

For reference, the model's lighting assignments are below:

| Decoder output | Front light (FLf) | Rear Light (FLr) | AUX 1 | AUX 2 | AUX3 | AUX 4 |
|----------------|-------------------|------------------|------------------|----------------|---------------|---------------|
| Lighting | Front white lamps | Front red lamps | Rear white lamps | Rear red lamps | No connection | No connection |

Class 27

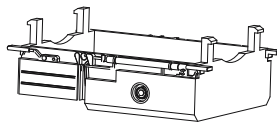
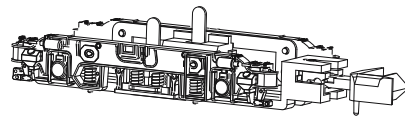
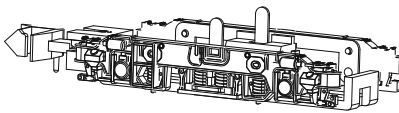
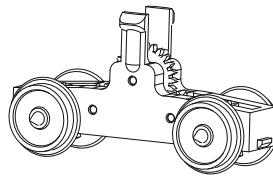
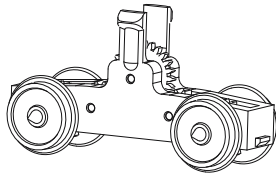
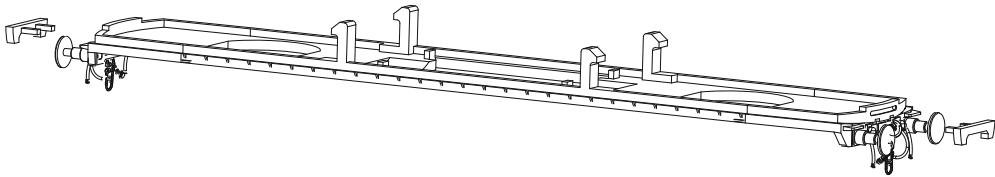
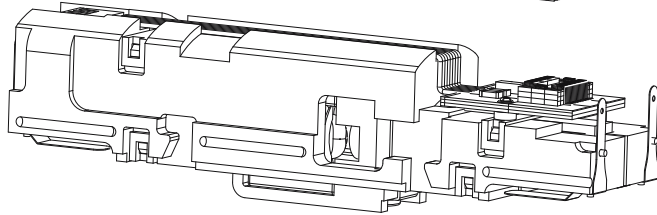
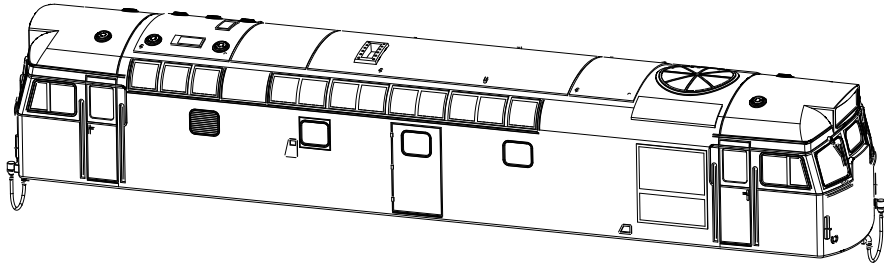

Oiling points for gears before test running, and removal of body for DCC installation

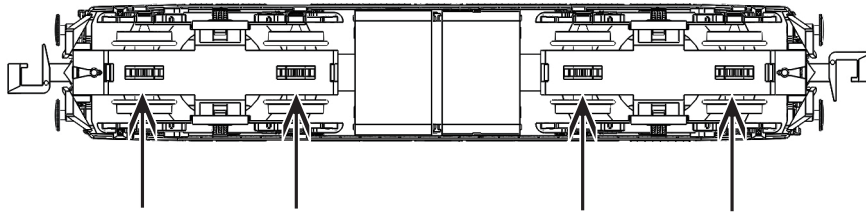

Normal oiling points into exposed gears without removing body

To remove body, simply pull body away from chassis to leave exposed chassis as image.

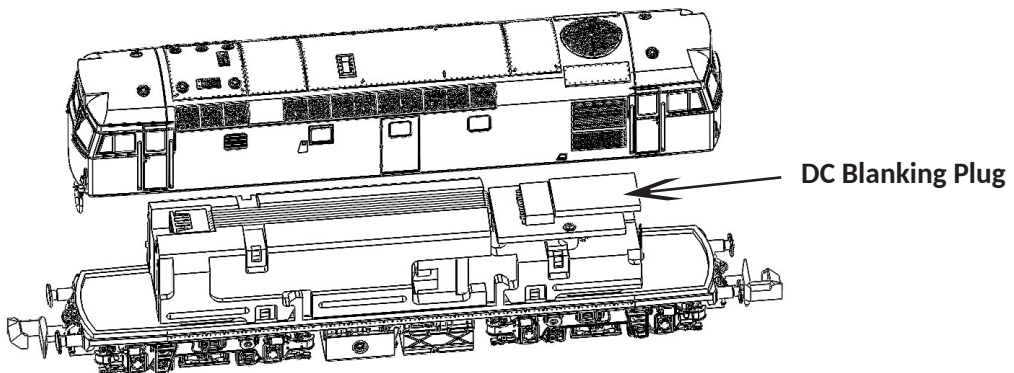

Be aware that there are two lighting connections between the body and chassis. It is not normally necessary to un-plug these to fit a decoder. Should unplugging be required, do not use the wires to pull the plug from the socket.

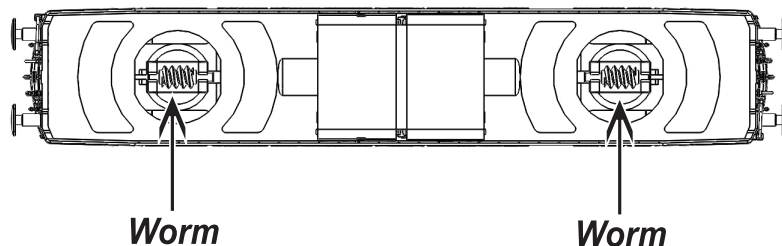

To expose drive worms and chassis for routine maintenance, simply pull the complete bogie assembly away from the chassis. The bogies are a pull out & push in fitting method. When refitting, ensure that the gear on top of the bogie tower meshes with the worm.

EUROPEAN REGULATIONS:

Dapol products conform to WEEE and RoHS requirements. If you have a need to dispose of any electrical part, please do so correctly.



Made in China