

dapol 00/H0 TRACKSIDE MODEL C016: WINDMILL

Made in the UK
using recycled plastic



Not suitable for
children under 14 years old



Please Note - The tools used to produce this model were made over 50 years ago. Over the period, changes have been made and it may be that reference numbers moulded into the plastic parts do not match the numbers used in these instructions. Therefore we advise you to FOLLOW the exploded diagram and instructions.

ASSEMBLY INSTRUCTIONS: It is recommended that the instructions and exploded view are studied and that the assembly is practiced before cementing together. Certain parts may need to be trimmed and may best be painted before cementing.

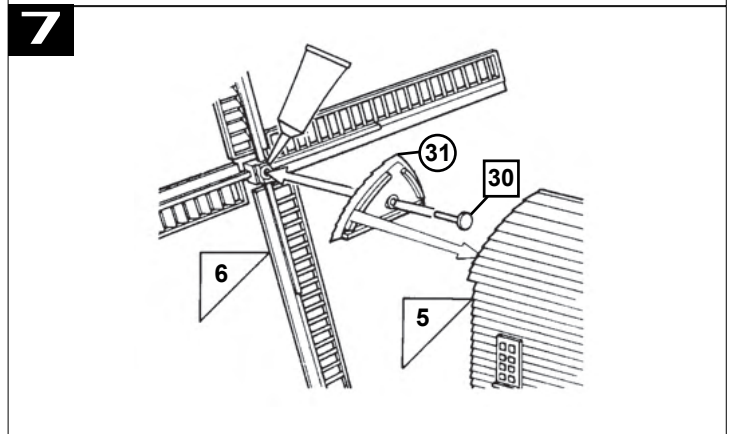
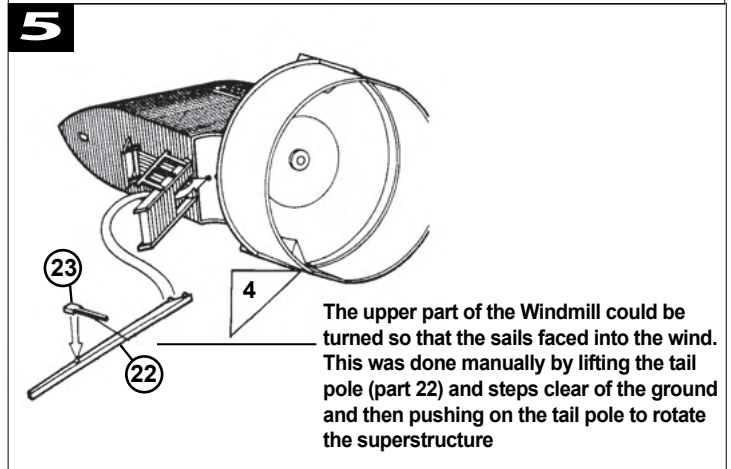
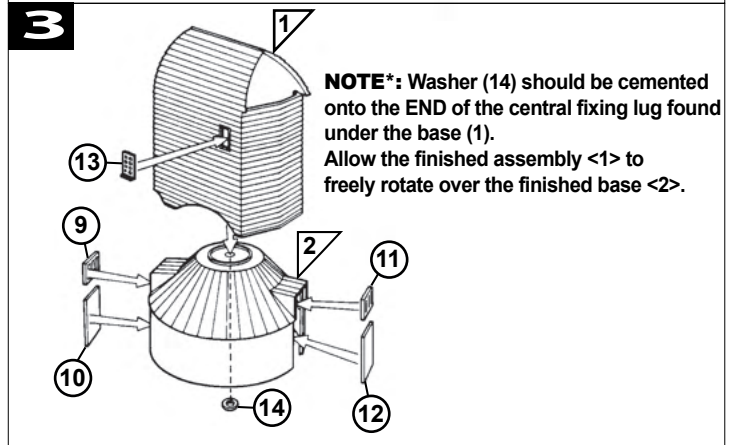
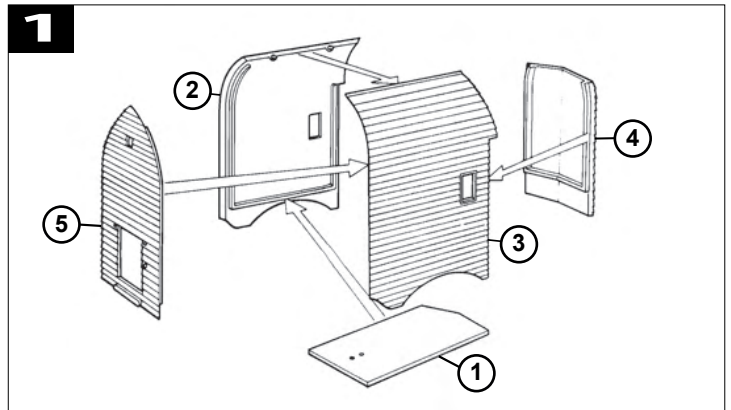
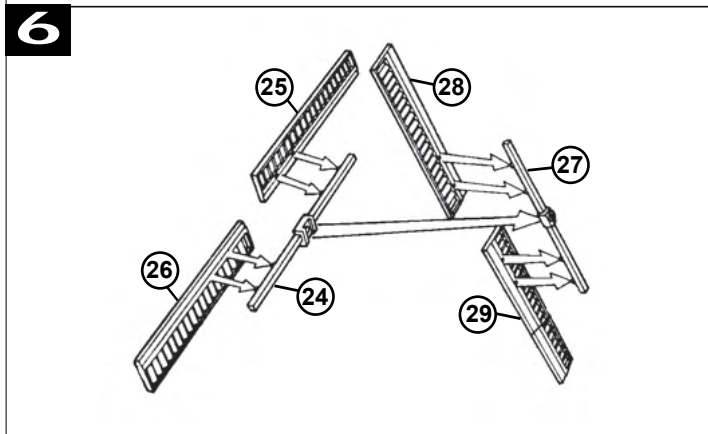
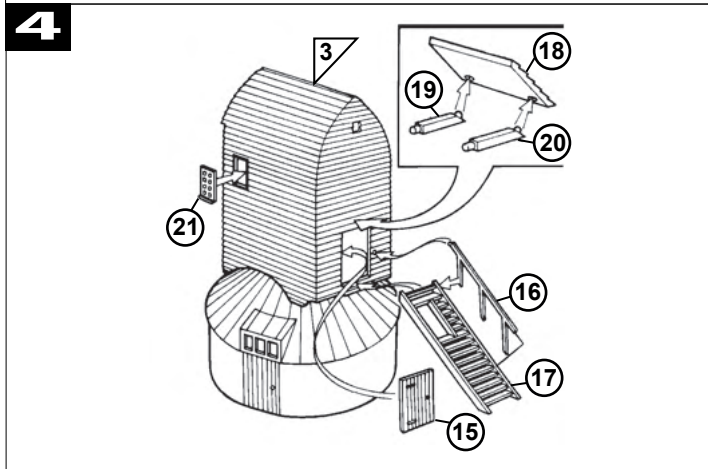
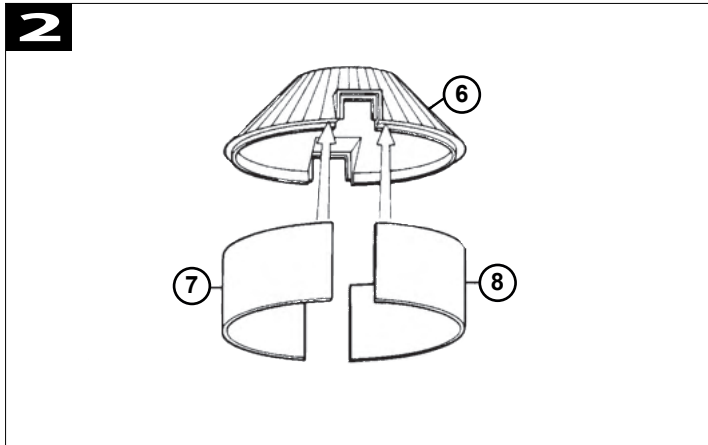

CEMENT



DO NOT CEMENT



ASSEMBLED SECTION

WARRANTY:

Parts can get bent during transit or by prolonged storage. However misshapen parts can be straightened by placing them in hot water to soften the plastic and then carefully manipulating them back into shape by finger pressure. Please be careful that the water does not cause harm to skin or fingers. In the event of parts being broken or missing, then you MUST return to the place of purchase (the seller). The seller will replace your kit and return the original kit to Dapol under their agreed contractual terms. Do **NOT** return to Dapol.

Finally please note that Dapol does not keep individual parts for any kit.