



Britannia Locomotive

IMPORTANT INSTRUCTIONS

Please read BEFORE using this model

UNPACKING & HANDLING YOUR LOCOMOTIVE:

Your model contains delicate precision parts. Please handle accordingly.

Removing your model from its case: Use the two 'ears' found at each end of the inner plastic clamshell, to remove the model along with its foam packing. When removing from clamshell or foam, always do so above a soft surface to prevent damage if dropped. Always lift the locomotive and tender as a single unit. Please, take special care not to grip or crush the delicate steam valve gear and motion parts fitted to the locomotive wheels whilst handling.

Note that the driveshaft, (which transfers power from the tender to locomotive), will detach if the locomotive and tender are not lifted as a single unit. If the driveshaft disconnects from either the locomotive or tender, simply rotate the shaft to align the spigots with the slots in the funnel-shaped cowling, and gently push together until you feel the shaft clip into place. (Tip: Holding the model between your index and thumb by gripping the back of the cab and the front of the tender simultaneously, will usually prevent accidental disconnection of the driveshaft.)

A small protective packing piece has been inserted between the locomotive footplate and the tender. The packing piece must be removed before running the locomotive.

YOUR MODEL NEEDS LIGHT LUBRICATION AFTER EVERY 50 HOURS RUNNING:

An extremely light application of plastic safe * oil, such as Dapoil or Locolube before running in your model is required, followed by maintenance oiling after every 50 hours of running time. (Storage in hot environments may require more frequent applications). Please be aware that over-oiling the wheel bearings will interfere with the electrical pickup of your model. Therefore, we recommend you use a very fine artist's paintbrush to apply only the tiniest amount of lubricating oil precisely between the bearing surfaces, as follows:

- Place a droplet of plastic safe oil onto a hard, non-absorbent, surface;
- Use a very fine pointed paintbrush to transfer a very small amount of oil, precisely, onto the bearings at the points indicated in the diagram overleaf. (The oil should not be painted on but, rather, capillary action should be used to draw the tiniest amount of oil out of the tip of the brush into the bearing.)
- Dry the paintbrush by blotting with absorbent paper, such as kitchen towel;
- Re-apply the dry paintbrush onto the oiled bearing, to 'wick away' any excess oil. Repeat steps 3 and 4 until the only remaining oil is an extremely fine (almost invisible) coating at the precise point where the two components rub together.

Please keep oils and lubricants away from the Motor and electronic circuitry located inside the body. The motor is of advanced self-lubrication design, 'sealed-for-life', and lubricants may damage the delicate circuitry. Also, be aware that N gauge track should never be laid directly onto carpet, as dust and fibres will become entangled in your locomotive's finely detailed mechanisms.

*Your model supplier can advise on the best 'plastic safe' oils and lubricants available in your country.

' RUNNING IN ' YOUR LOCOMOTIVE

You will obtain quieter and smoother performance from your Dapol locomotive if you invest a little time 'running in' the motor and the motion parts. We recommend that you begin the 'running in' period by operating the locomotive on its own, at a moderate speed, for a period of at least half an hour in each direction. (The complete 'settling in' process often continues beyond the initial 'running in' period, and you will notice that the locomotive gradually runs quieter and smoother over several weeks of normal coach/wagon hauling operation.)

ACCESSORY PARTS:

Additional detail parts are supplied in plastic bags within the outer case & fitted as follows:

- Couplings can be removed or supplied alternatives fitted by simply pulling the existing Rapido type away from the locomotive. Alternatives simply push fit.

Please note that the following parts may interfere if a coupling is fitted.

- **Pipes:** Are fitted in the order shown and push into matching openings in the buffer beam. If desired a small spot of adhesive can be used to secure.
- **Dummy Screw Coupling:** This is clipped into the hook already placed on the buffer beam.

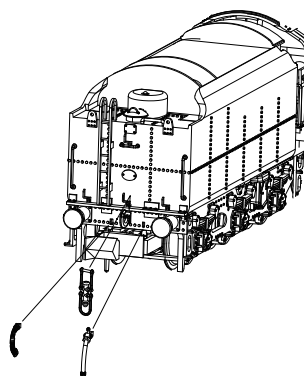
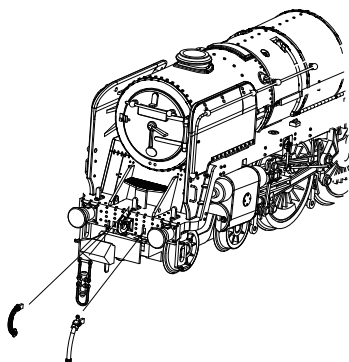

DC OPERATION:

If you wish to run the model on standard DC – then do nothing. Our PCB will automatically recognise that you have a DC controller and will allow operation at normal DC parameters. **Important Note:** This model should only be used with a DC controller designed for model railways rated at 12V DC nominal voltage. When (optionally) fitted with an appropriate DCC decoder it may also be used with a compatible DCC control system.

DCC OPERATION:

Our model is fully DCC ready. The model is fitted with a DCC board which features a 6-pin plug pre-fitted with a 'blanking plug'. Carefully remove the blanking plug and insert the decoder of your choice. Before converting to DCC please ensure that your decoder will fit the model, as some decoders are large and could have a thick protective outer hroud. To expose the PCB, simply pull the tender body away from the chassis using finger pressure. Fit your decoder and programme as normal. Reclip the body.

No special CV settings are required to operate this model.

Oiling points for gears before test running, and removal of body for DCC installation

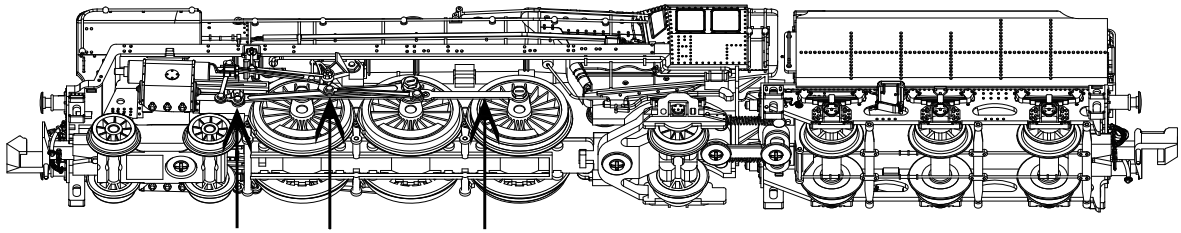

Motion Oiling Points (both sides)

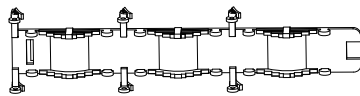
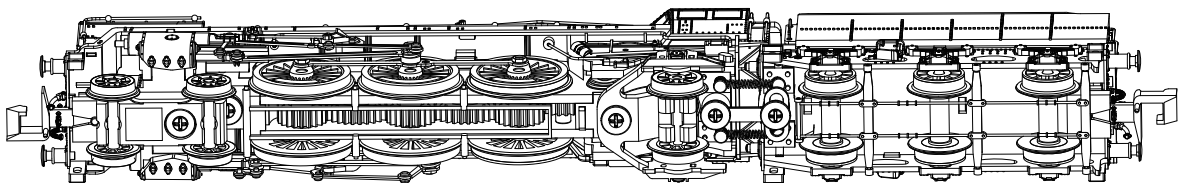

Keeper Plate

Pry keeper plate open using small flat screwdriver
Apply oil into gears as shown
Reassemble the keeper plate

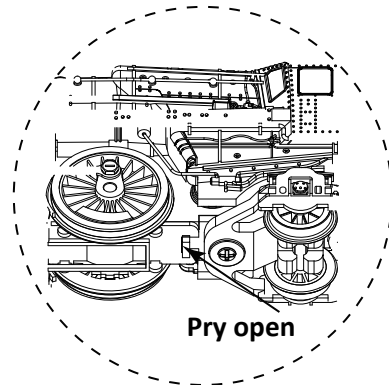

Pry open

Please note:

- i) To prevent damage, the driveshaft will detach if the locomotive and tender are not lifted as a single unit. To re-attach, simply rotate the shaft to align the spigots with the slots in the funnel shaped cowling. A gentle push will re-insert the driveshaft end. A spare shaft is included in the accessory pack.
- ii) The tender does not need to be removed to complete the oiling process.

Gear oiling points

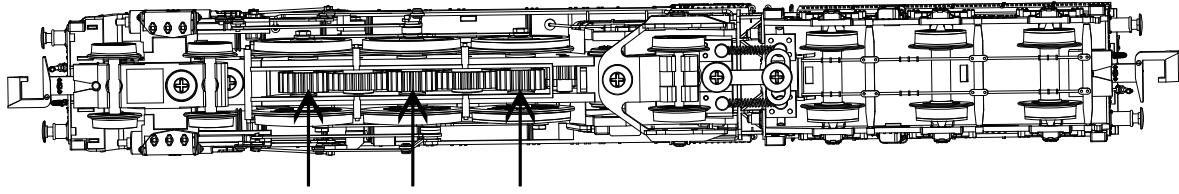

Oil into the exposed gears

To remove body, simply pull tender body away from chassis to leave exposed chassis as image.

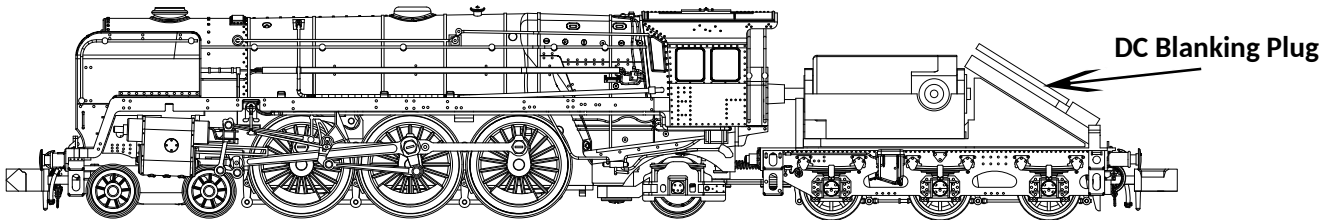
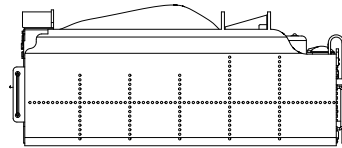

WARRANTY:

Please refer to separately provided warranty paperwork for details.

EUROPEAN REGULATIONS:

Dapol products conform to WEEE and RoHS requirements.

If you have a need to dispose of any electrical part, please do so correctly.



Made in China