

dapol

Gauge

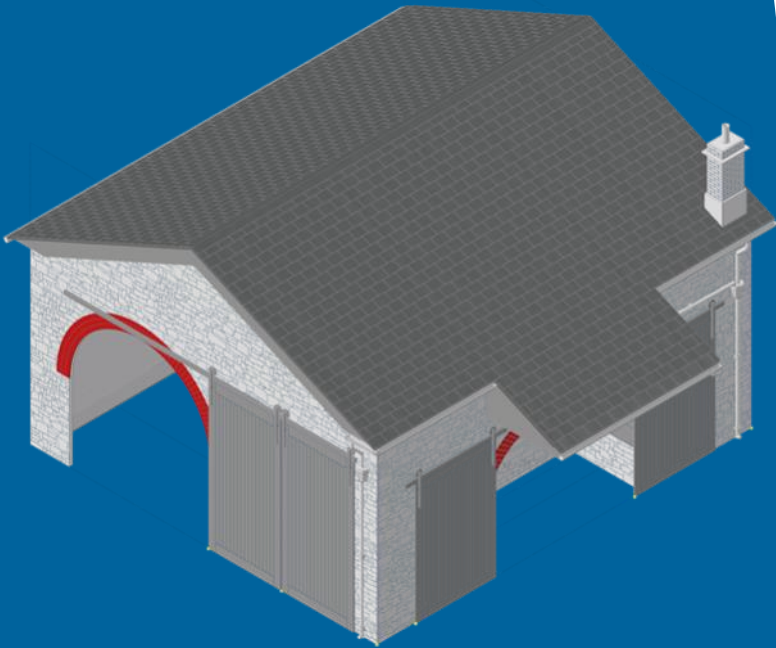

7B-002-003

Great Western Railway Goods Shed

Based on Ashburton



Read Before Building

Estimated Build Time:
6-8 hours

This is a very complex kit, we strongly recommend taking your time building it. It is also very important to keep a clean work area as the card is permeable and can stain very easily.

We recommend using a standard PVA glue slightly diluted with water. We do not recommend any fast drying glues, as they can dry too quickly, making any small positional adjustments difficult. It's best to apply the glue using a small paintbrush or cardboard offcut.

Parts cannot be bought individually. Spare or replacement frets can be bought £10 each for large frets and £7 each for small frets by contacting sales@dapol.co.uk

Printed instructions are available free of charge by contacting sales@dapol.co.uk

But most of all. Enjoy.

Checklist

- Clear 11
 - C5
- Real Grey 24
 - A7 (x4)
 - C7 (x4)
 - H1
- Real Grey 24
 - C1
- Real Grey 25
 - C3
- Real Grey 26
 - A1
- Real Grey 27
 - A3
- Real Grey 28
 - B1
 - C4b (x2)
 - C6
- Real Grey 29
 - D1
 - C4a (x2)
 - C6
- Real Grey 30
 - D3
- Real Grey 31
 - B3
- Real Grey 32
 - E3
 - E5 (x2)
 - E7
 - H1
 - H2
 - H3
 - H4
- Red Brick 3
 - A4
 - B4
 - D4
- Slate 31
 - F1
 - F2
 - F6
 - G1
- Slate 32
 - F1
 - F2
 - F7
 - G2
- Slate 33
 - F5
- Slate 34
 - F4
- Slate Thin 20
 - Tiles for F6
- Slate Thin 21
 - Tiles for F7
- Slate Thin 22
 - Tiles for G2
- Smoke 22
 - A5
 - A7 (x4)
 - A8 (x4)
 - B5
 - B6 (x2)
 - B7
 - D5
 - D7 (x4)
 - D8 (x4)
 - E2
 - E9
 - G3
 - H6
 - H7
 - H8
 - H9
 - H10
 - H12
- Smoke 23
 - A6 (x2)
 - D6 (x2)
 - F8 (x2)
- Smoke 24
 - F3 (x3)
- White 78
 - C2
- White 79
 - D2
 - C5 (x2)
- White 80
 - D2
- White 81
 - B2
- White 82
 - E1
 - E4
 - E6 (x2)
 - E8
 - H5 (x2)

1

A1 & A2

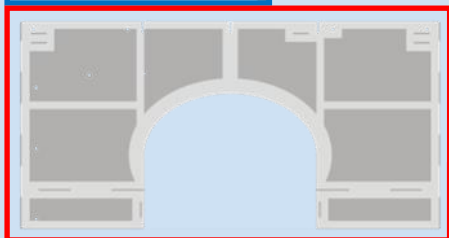
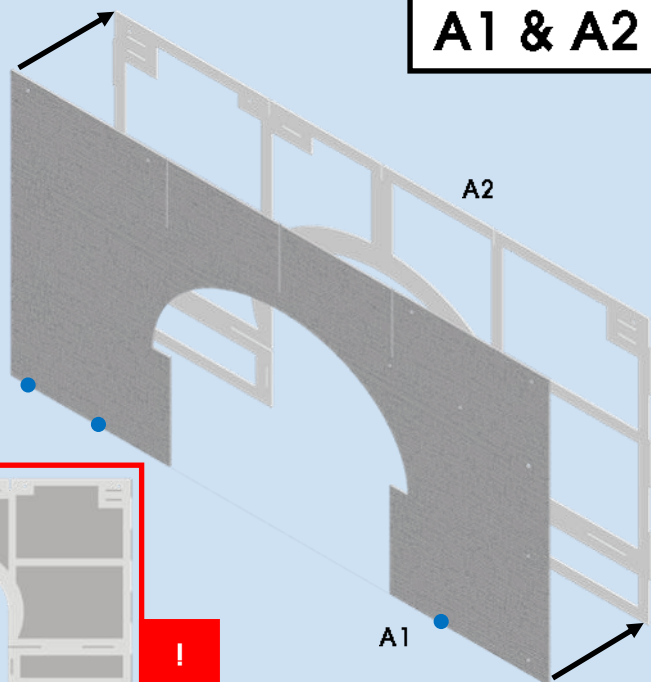
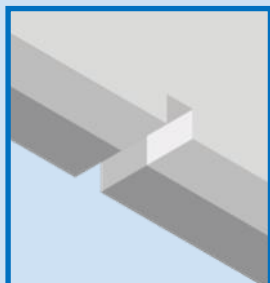

2

A3

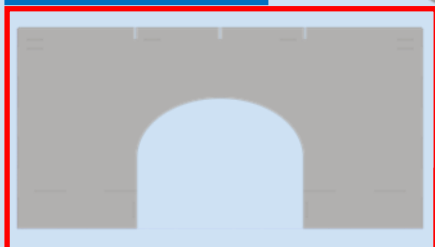
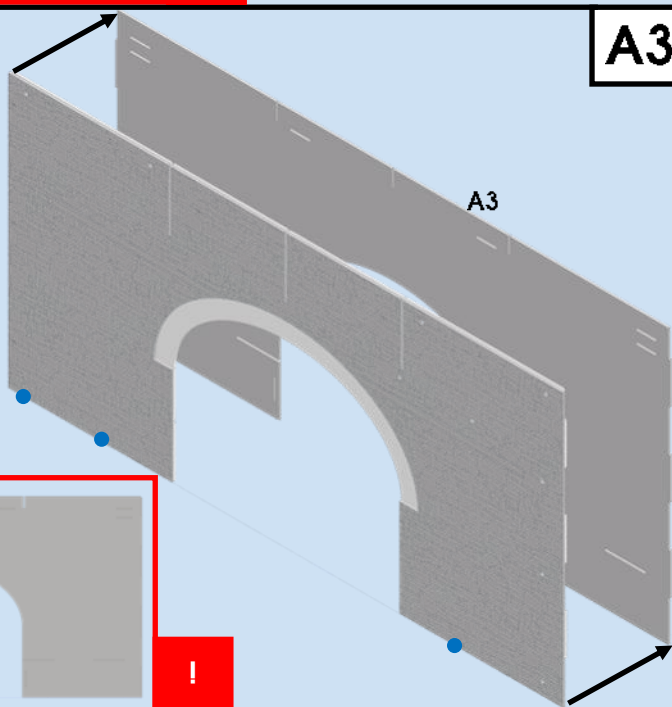
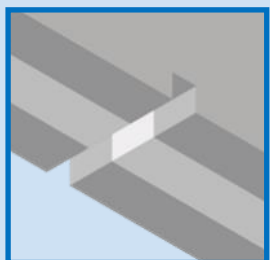

3

A4

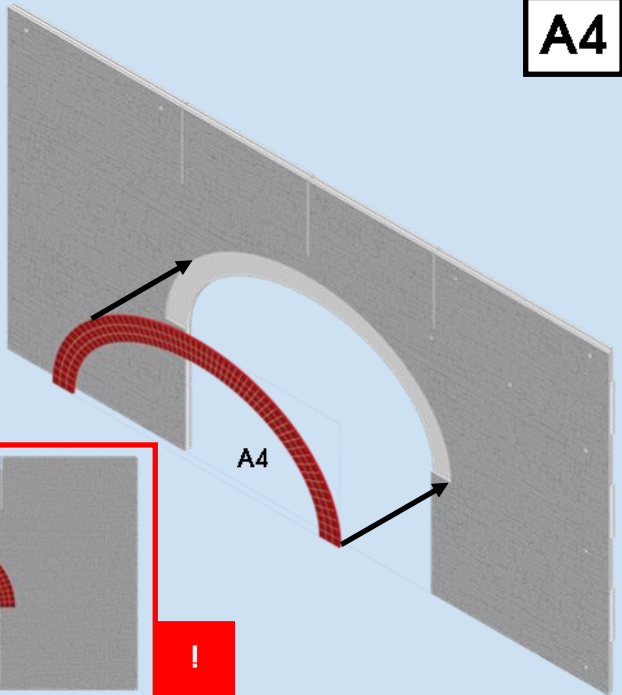
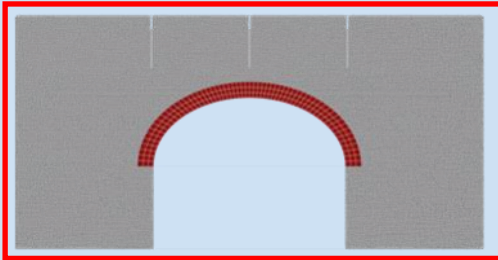

4

E7 & E8

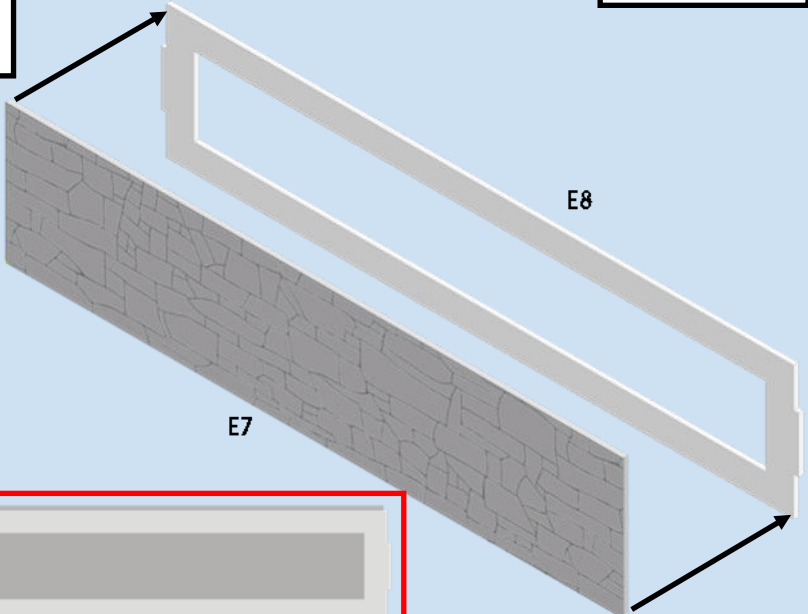
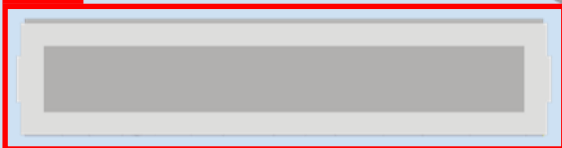

5

E5 & E6

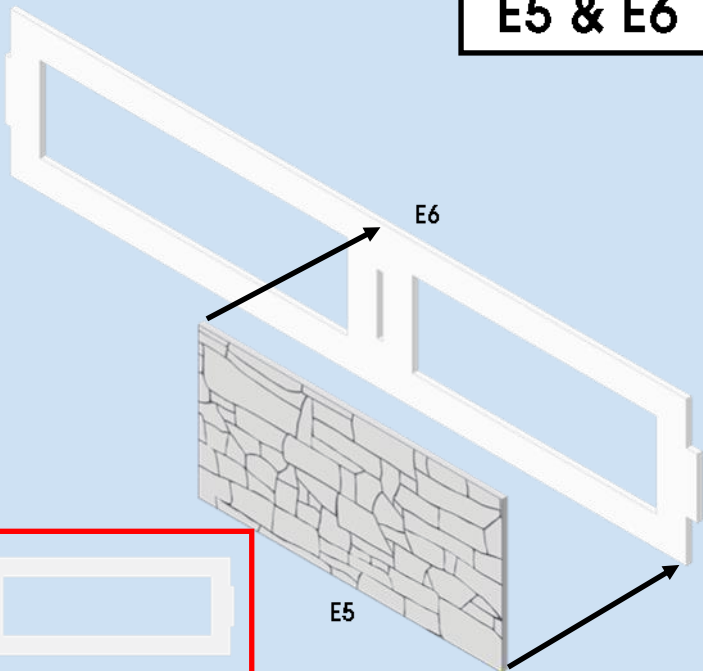

6

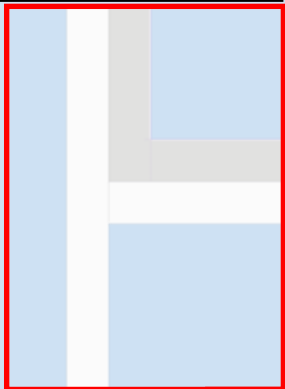
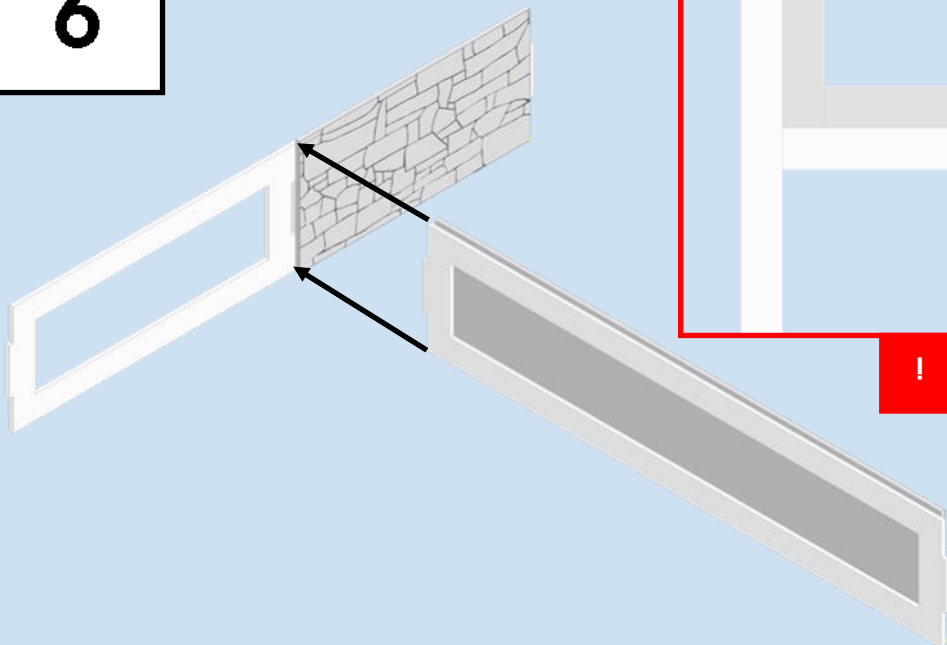

7

E5 & E6

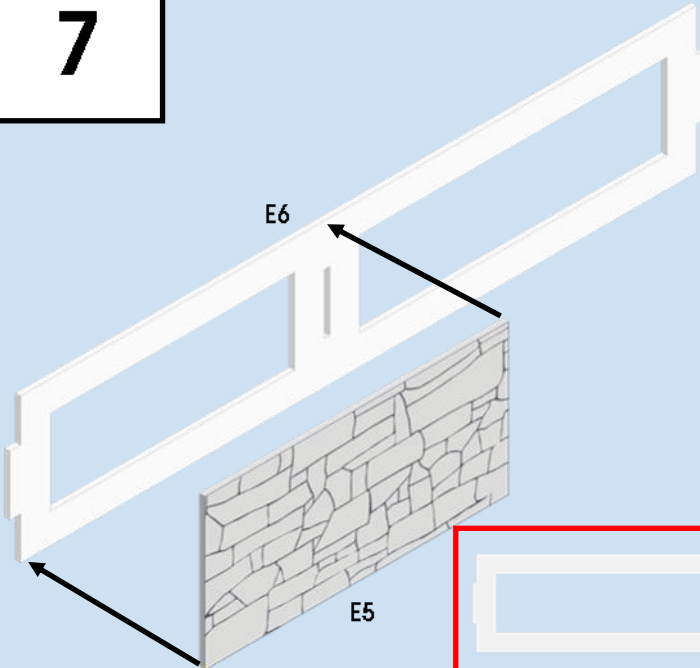

8

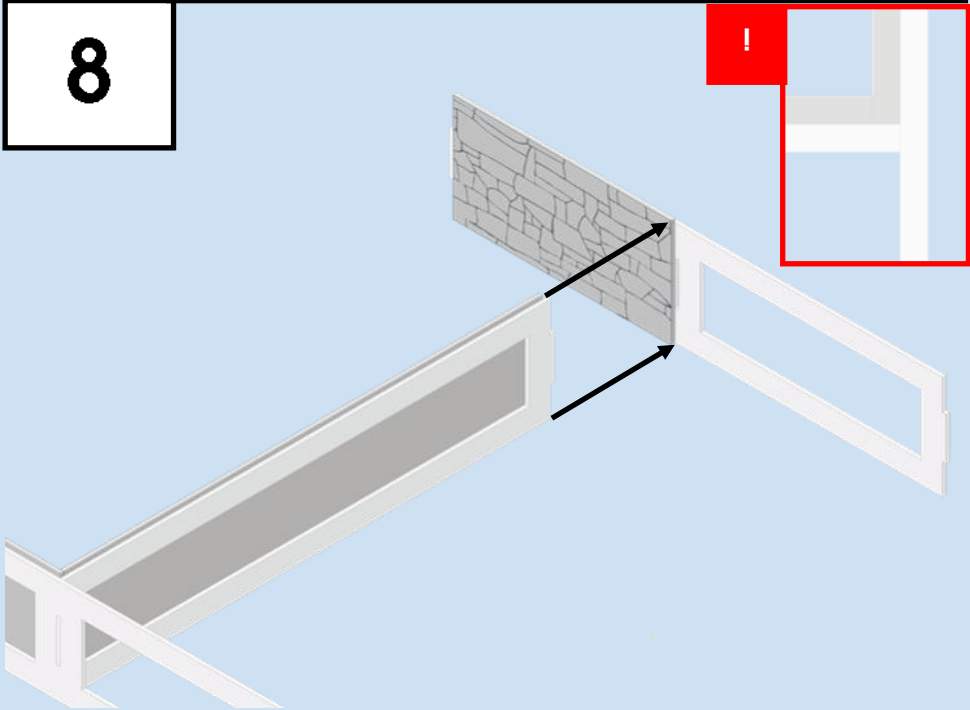

9

E3 & E4

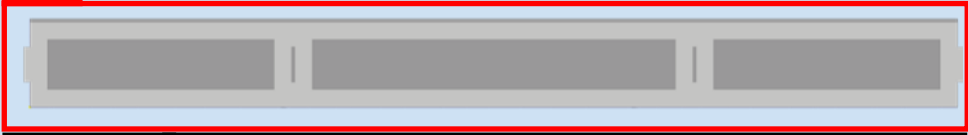
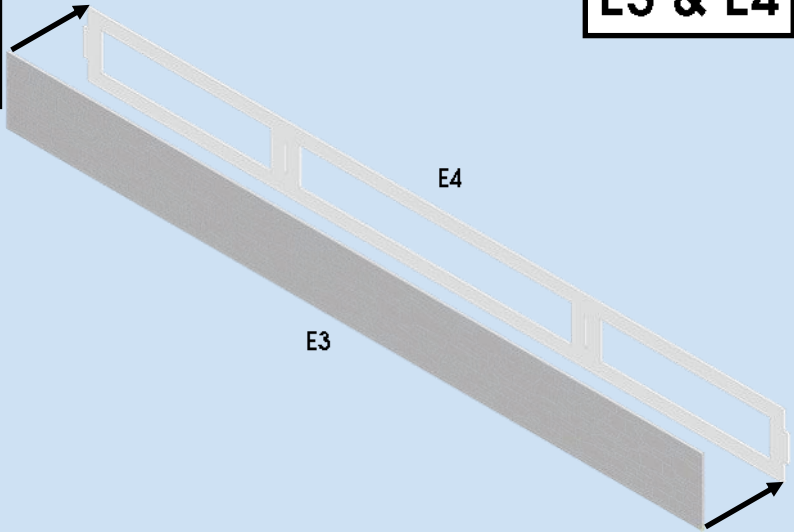

10

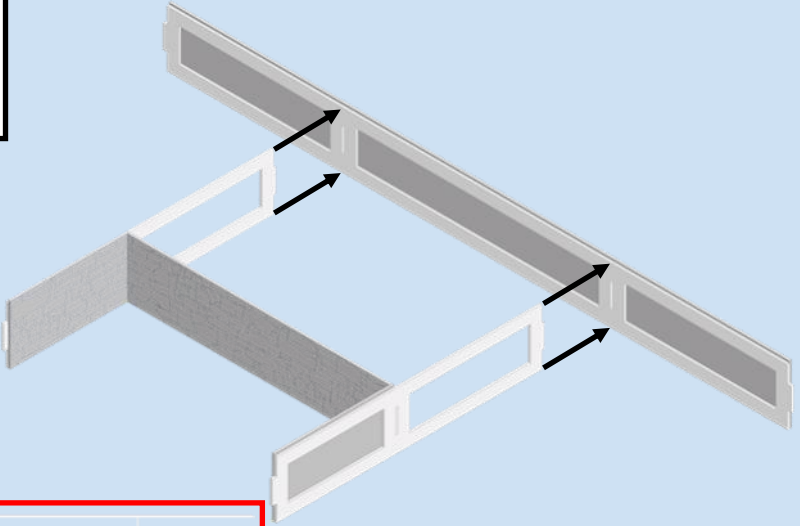

11

E1 & E2

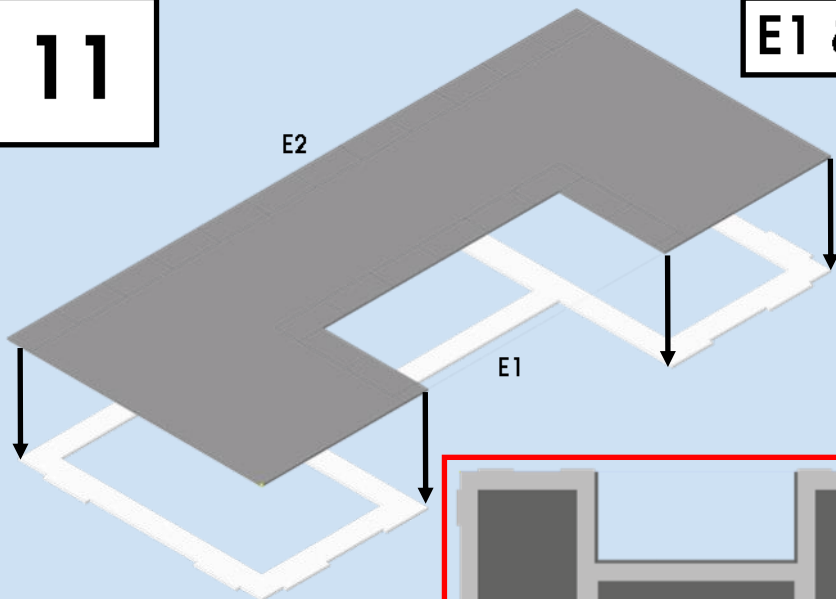

12

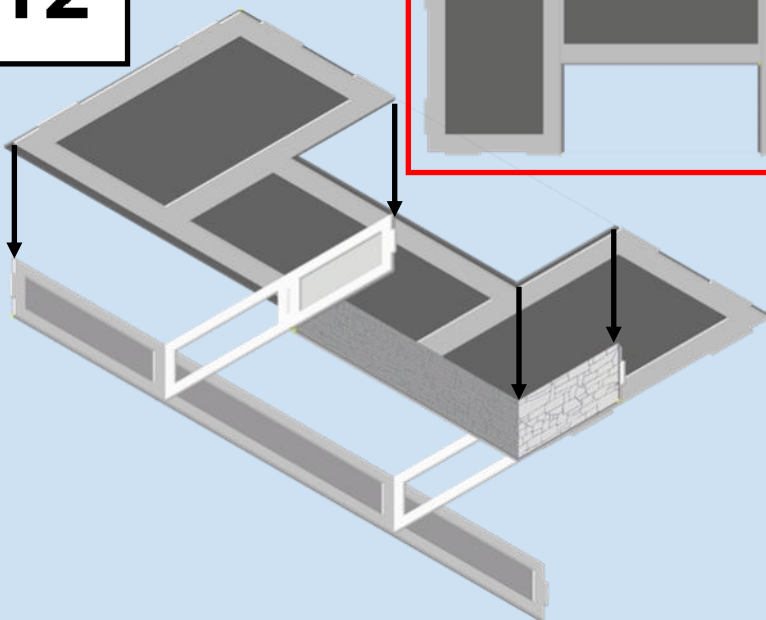

13

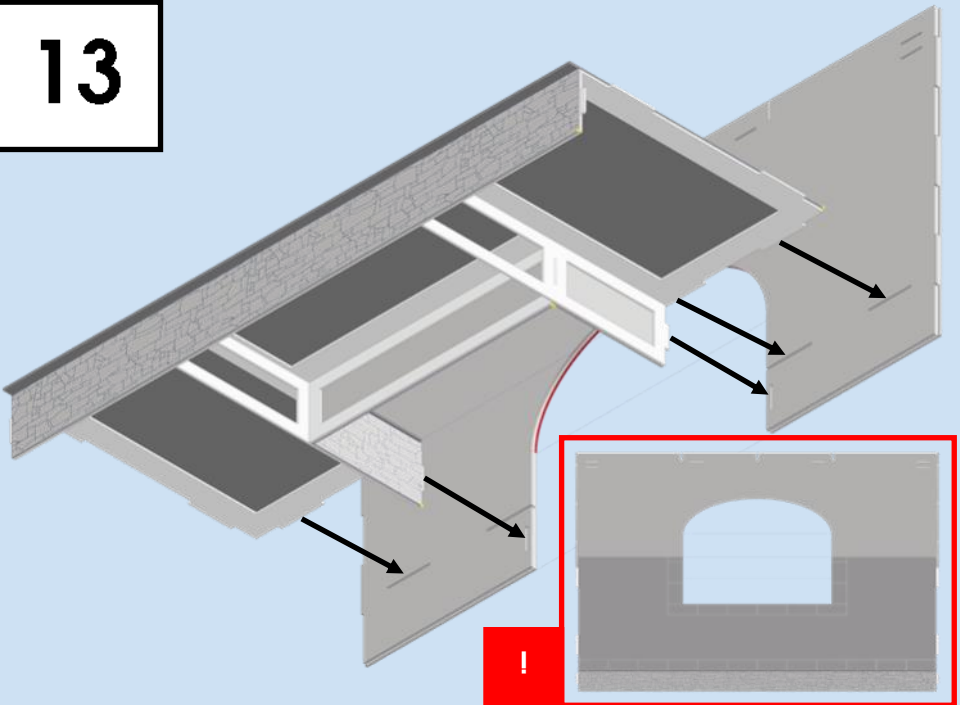

14

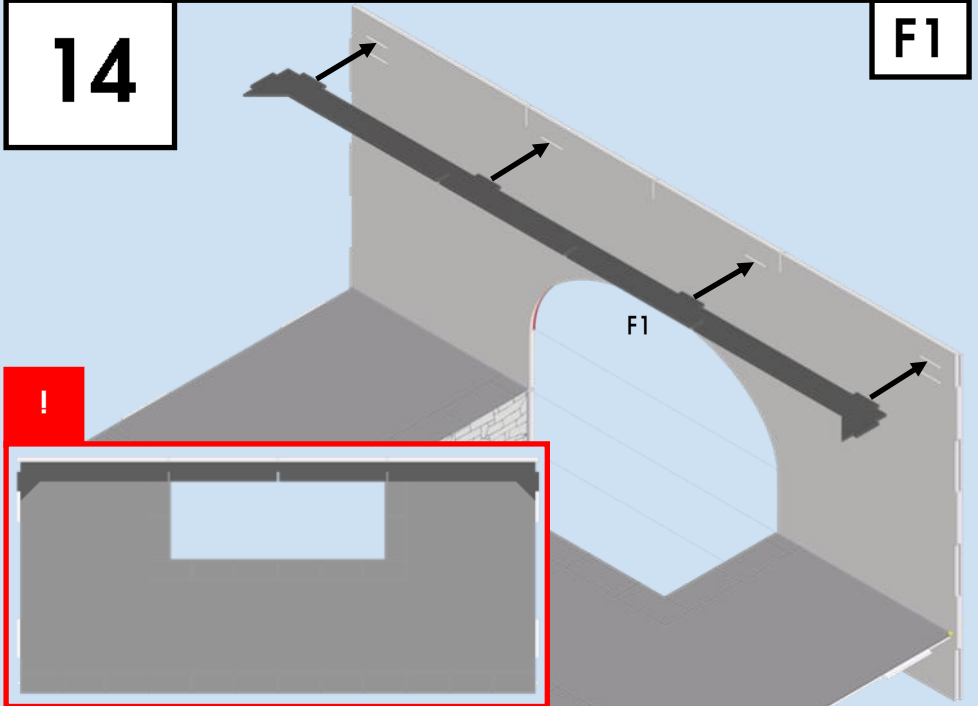

15

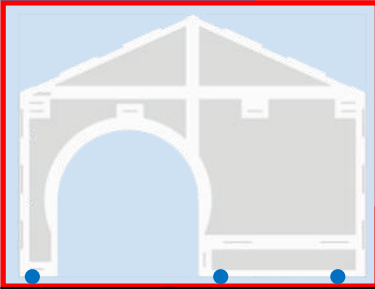
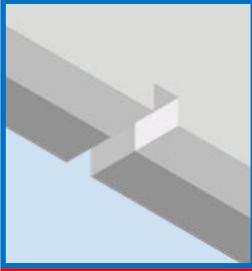

B1 & B2

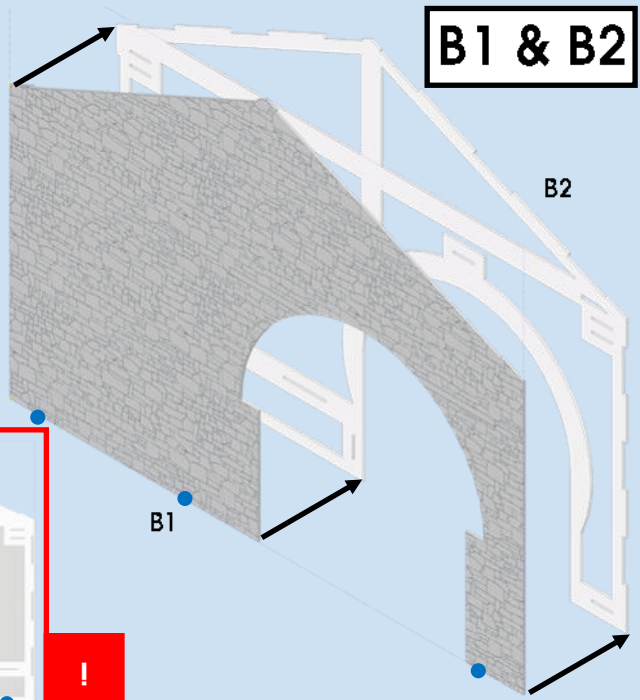

16

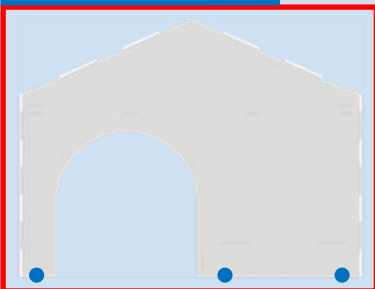
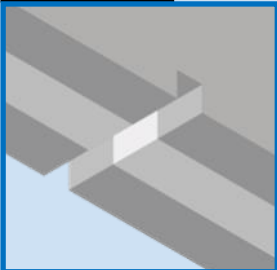

B3

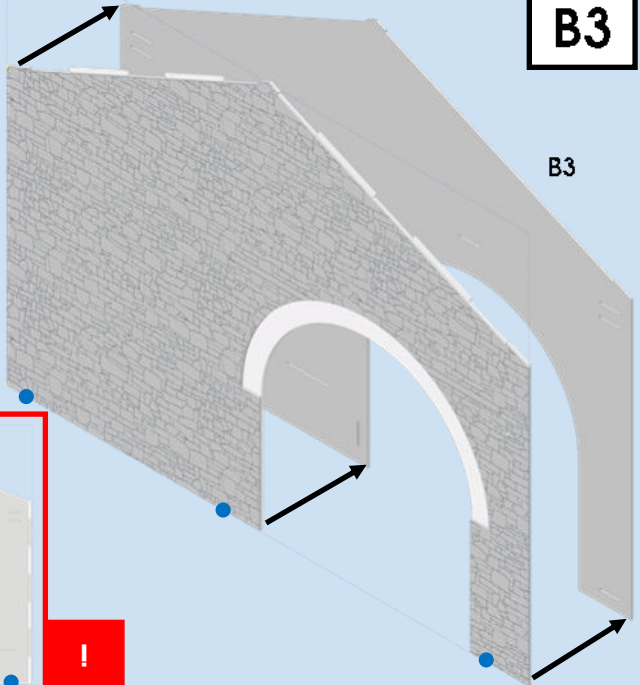

17

B4

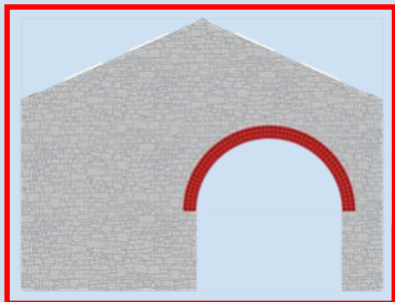
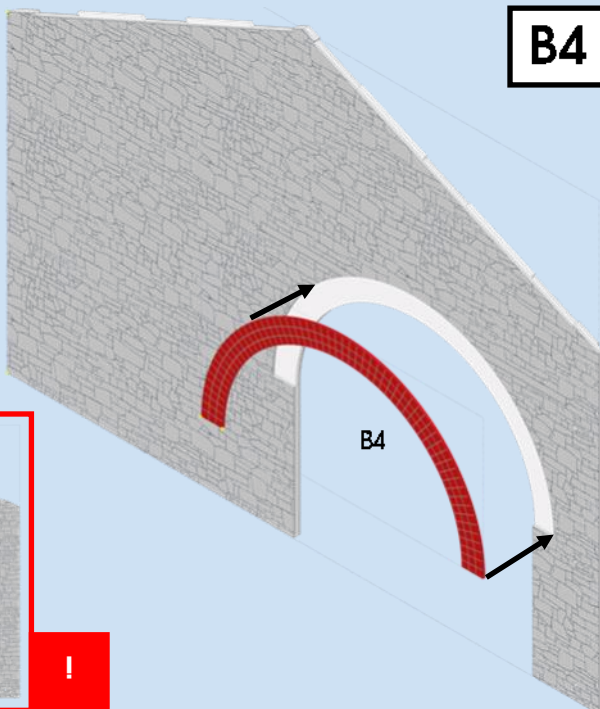

18

F2

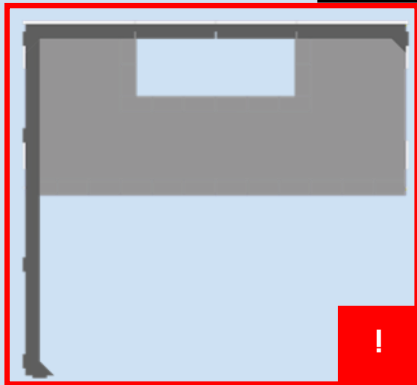
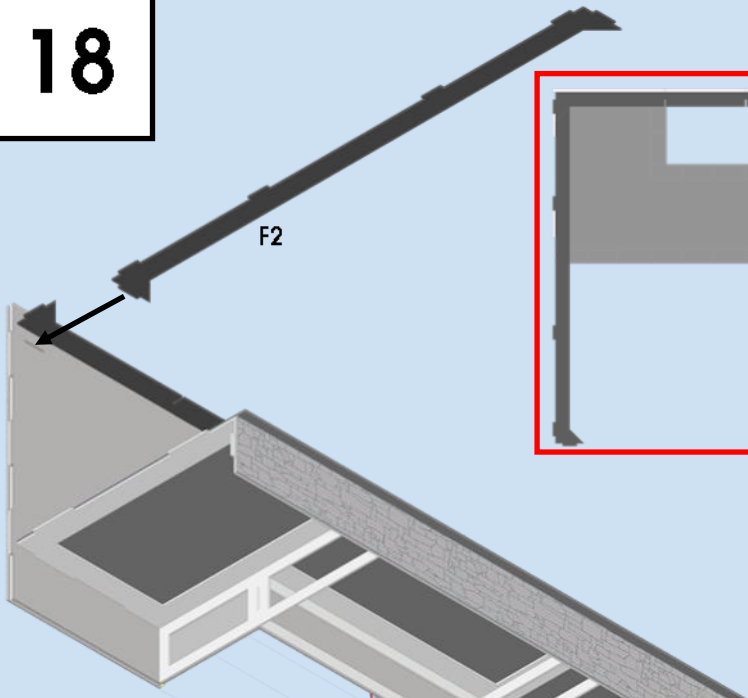

19

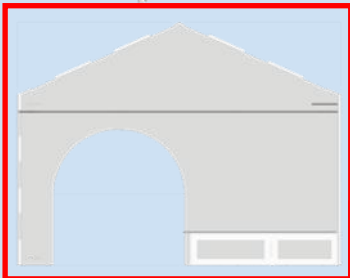
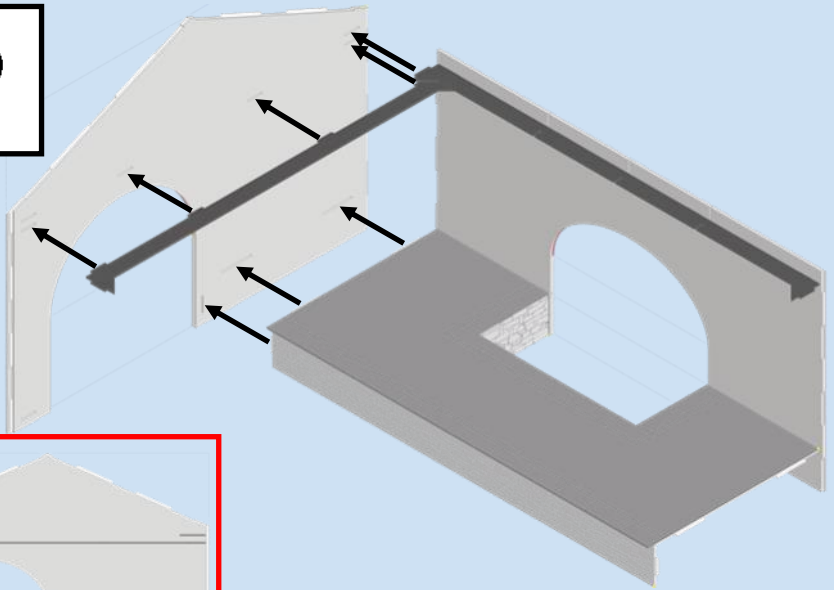

20

C1 & C2

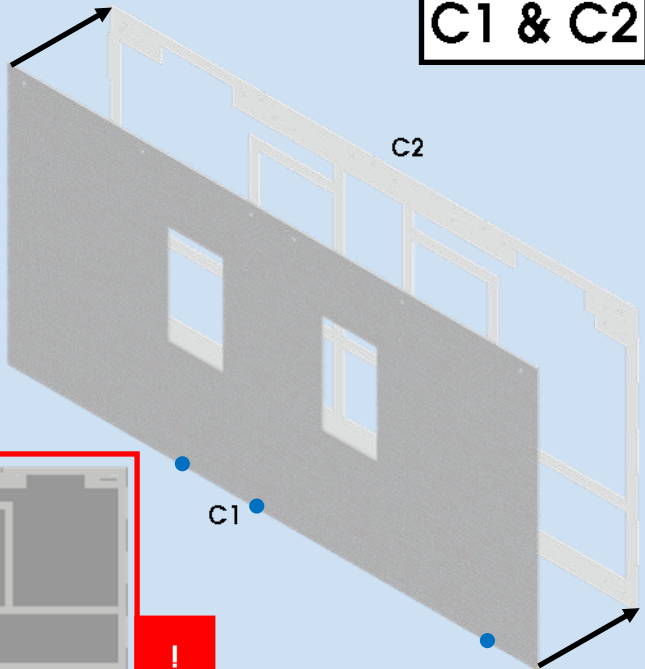
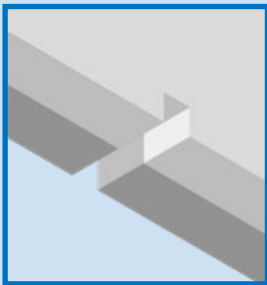

21

C3

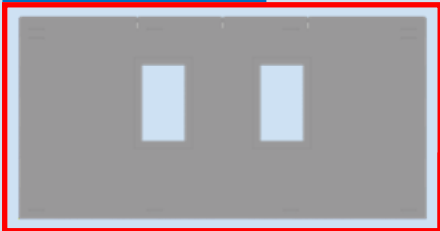
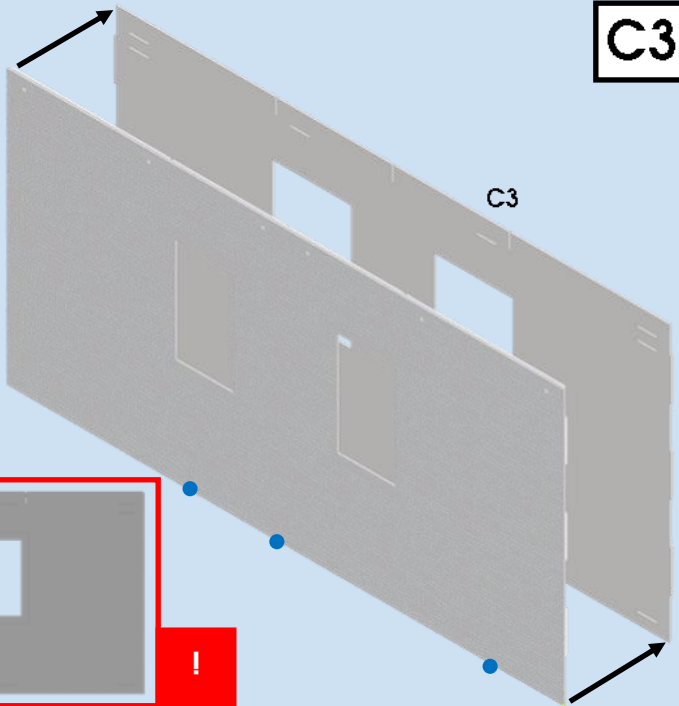

22

C4a(x2) & C5(inc. Glazing)

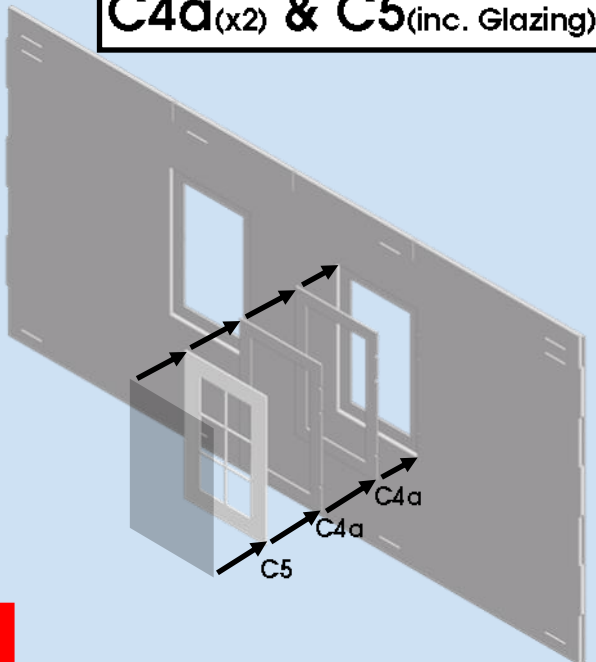
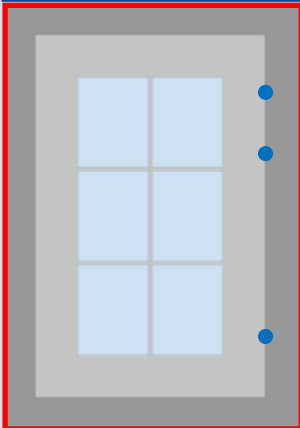

23

C4b(x2) & C5(inc. Glazing)

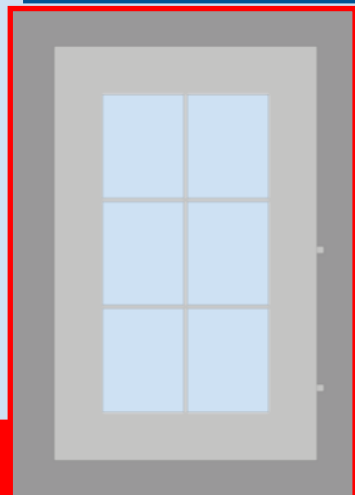
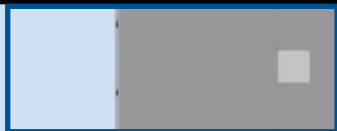
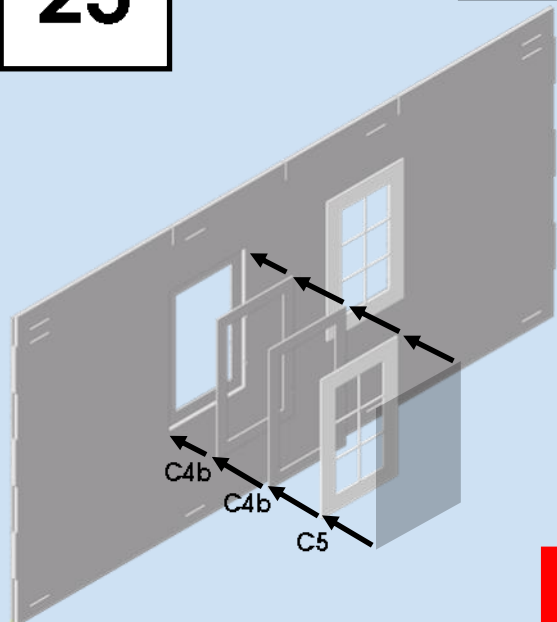

24

E9 & F1

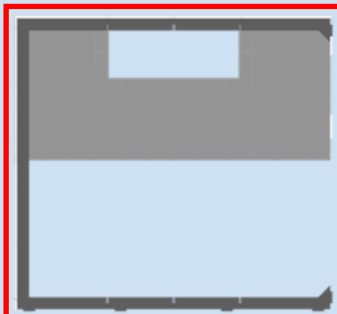
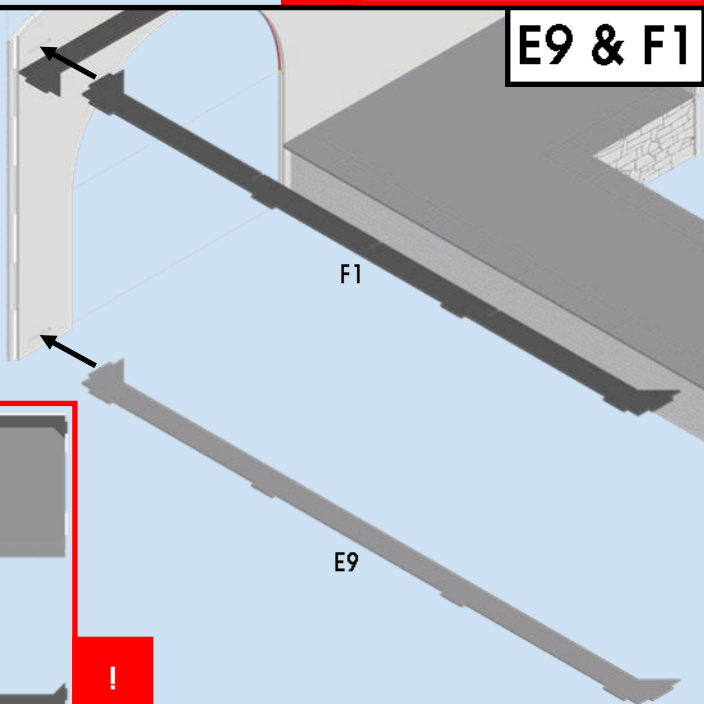

25

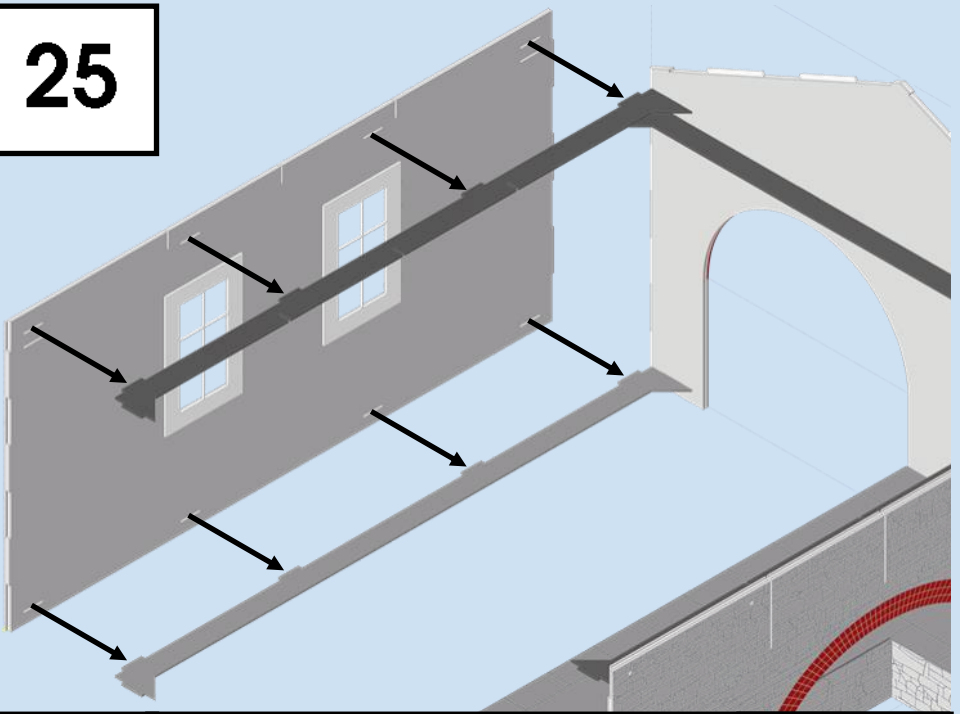

26

D1 & D2

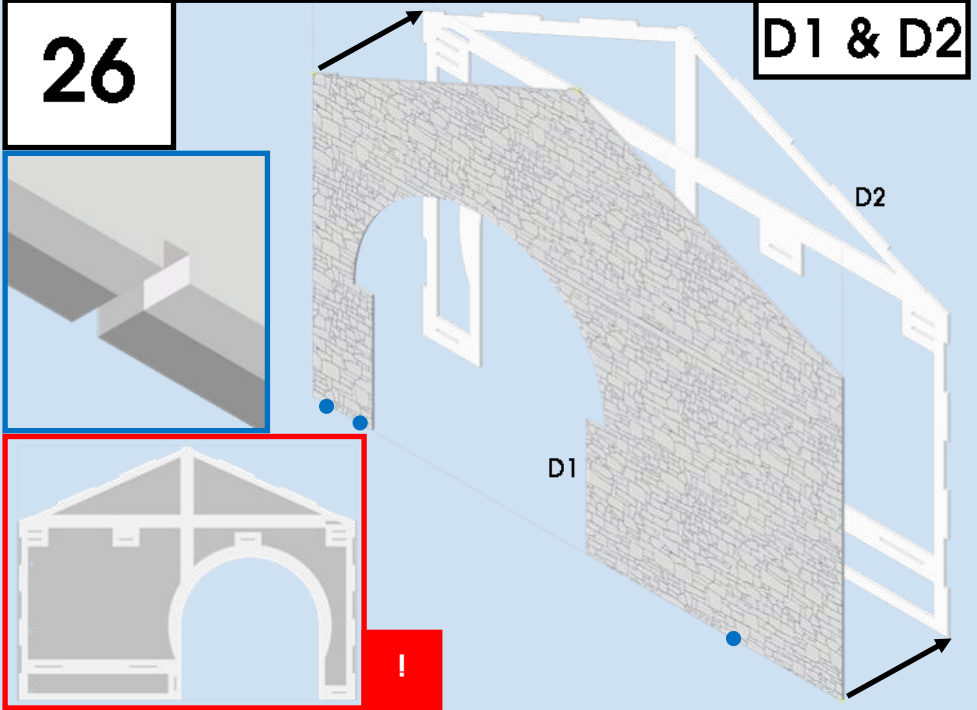

27



D3

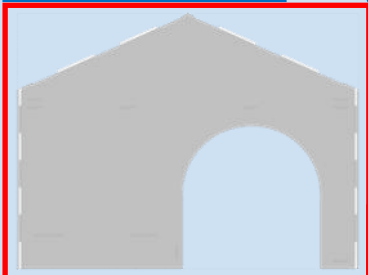
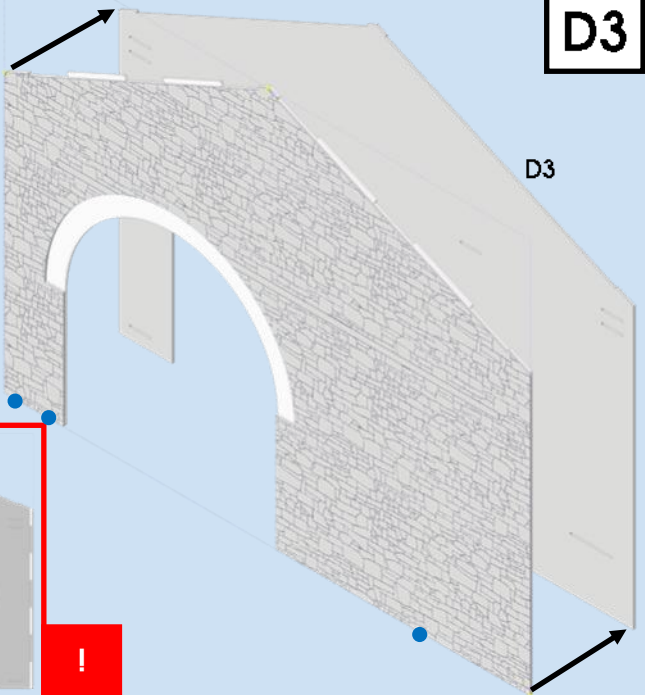

28

D4

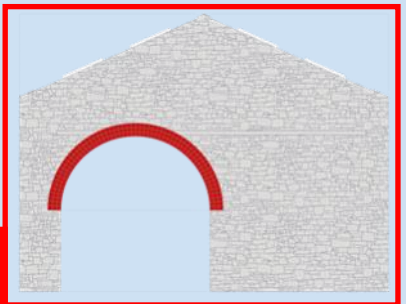
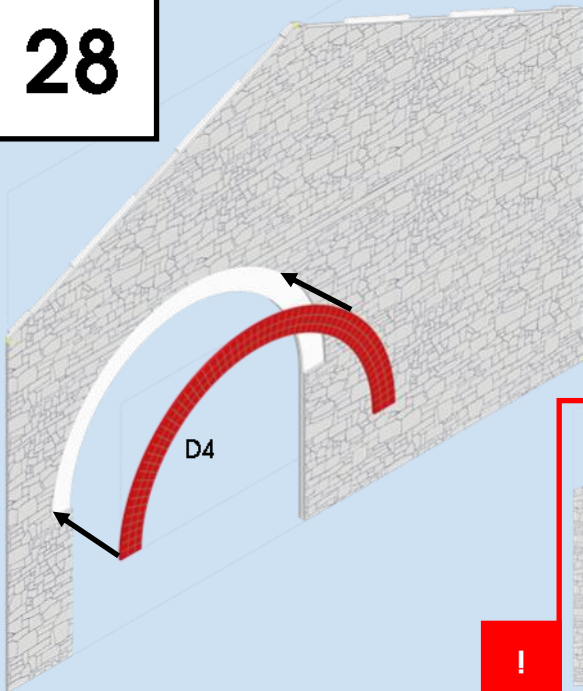

29

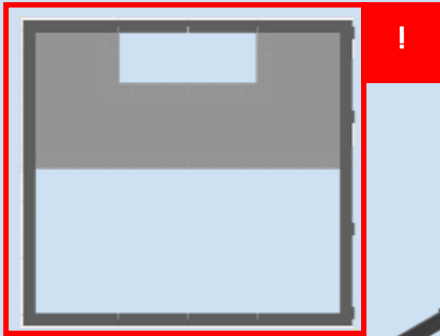

F2

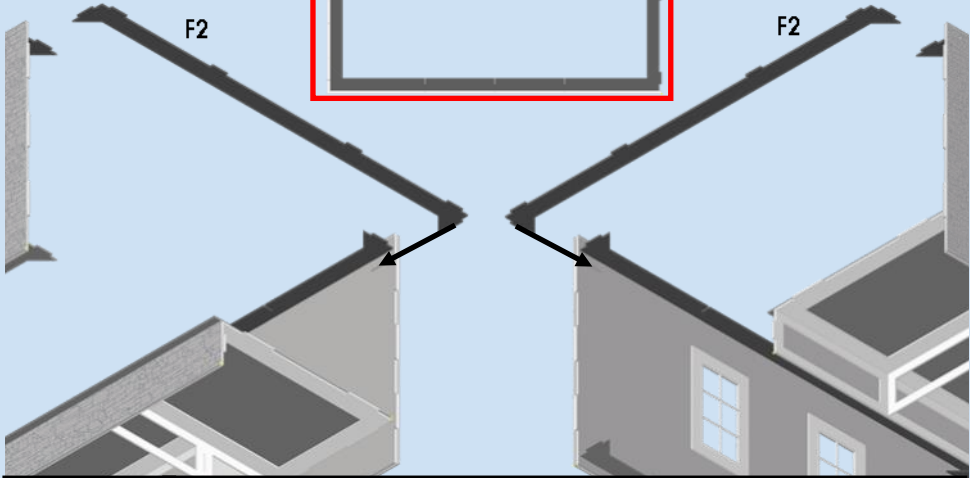

30

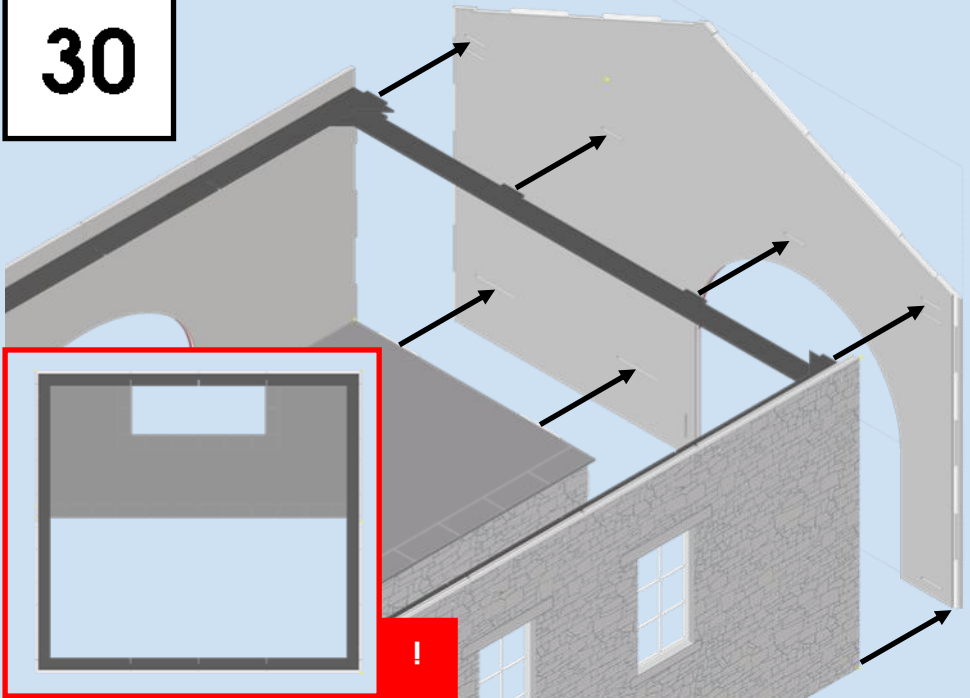

31

!

F3(x3)

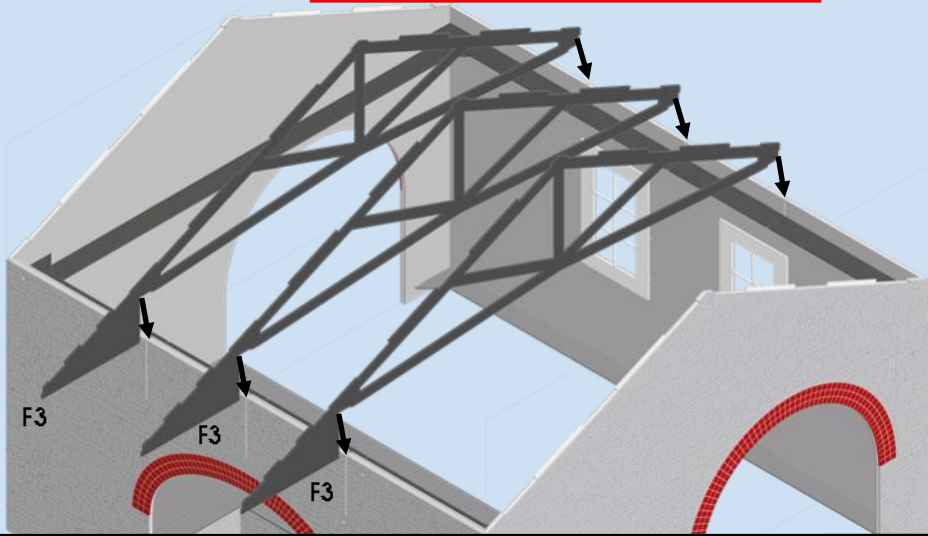

32

F4

F4

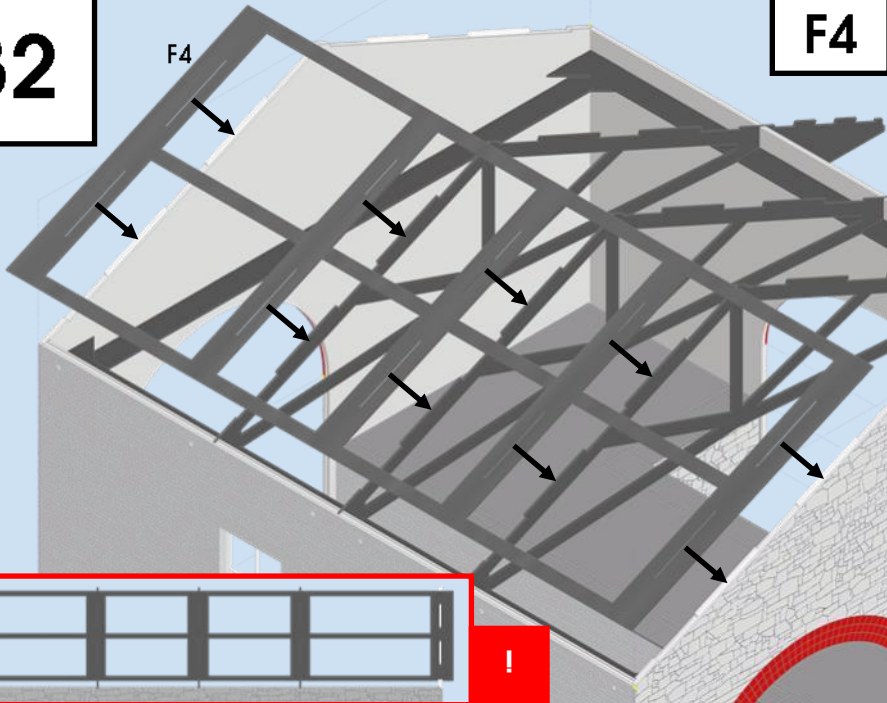

33

F5

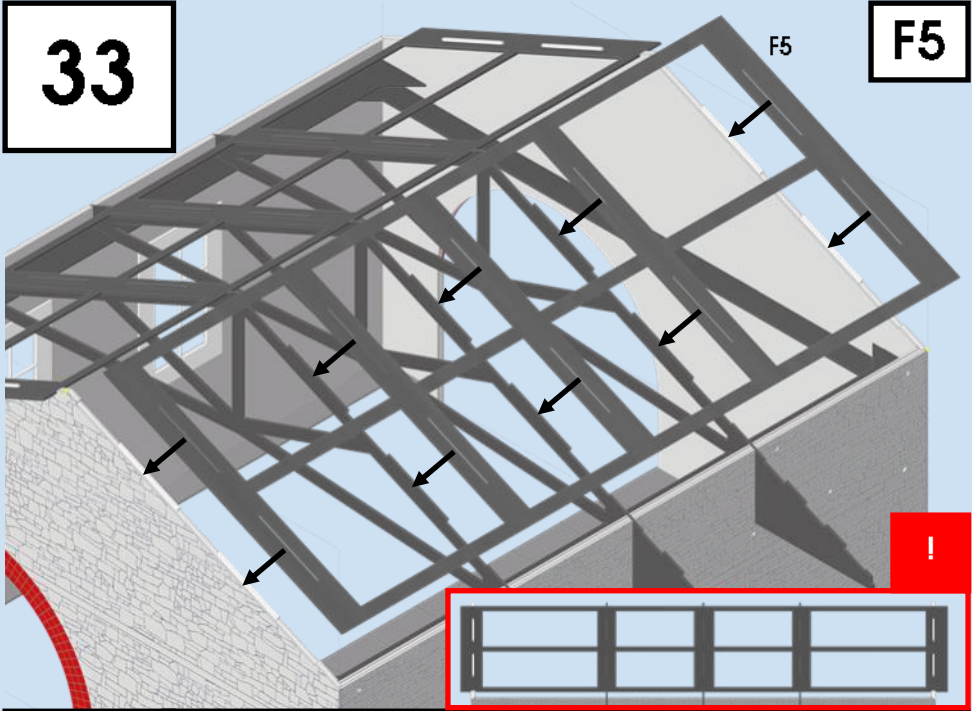

34

F7

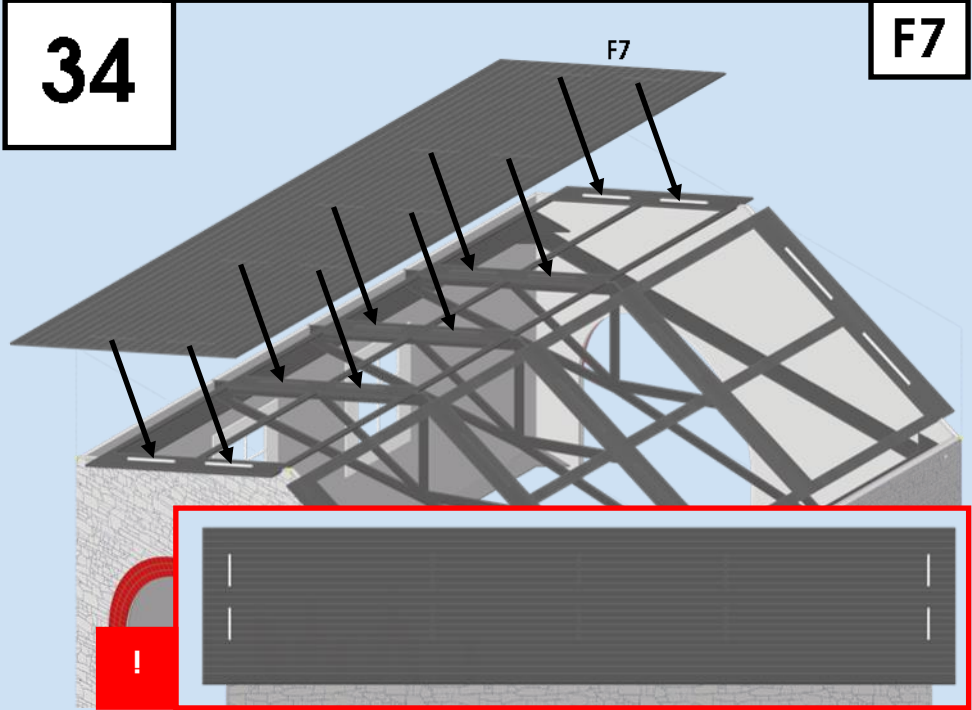

35

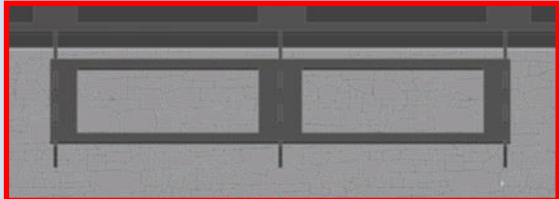
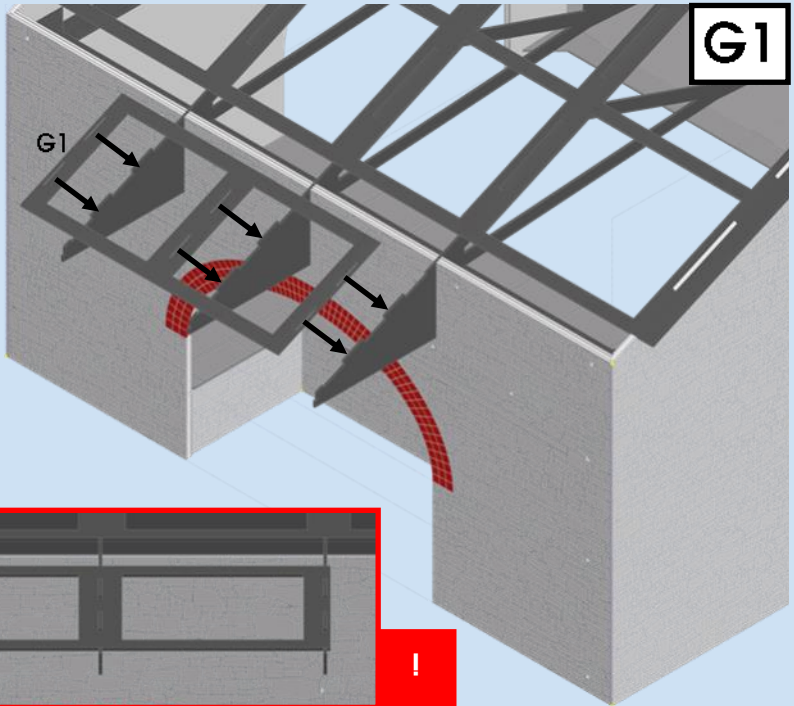

36



F6

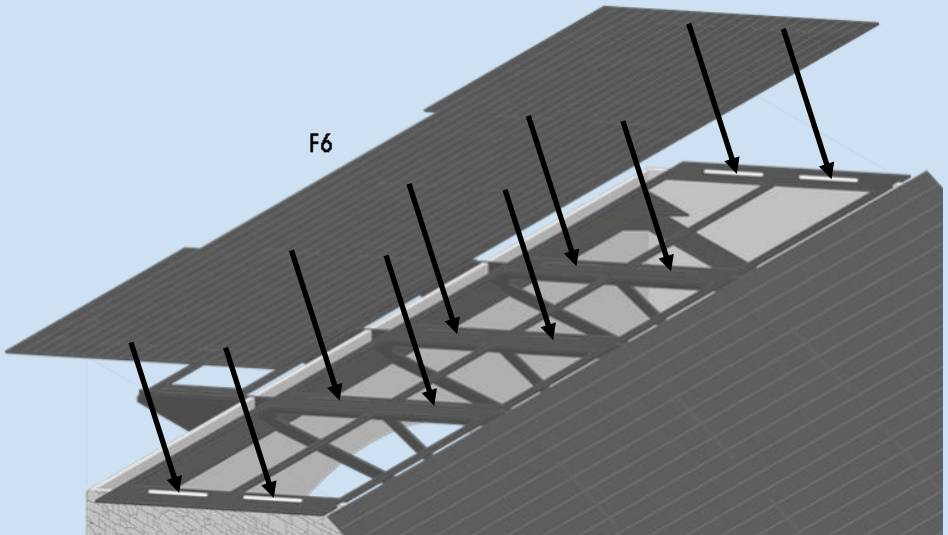

37



G2

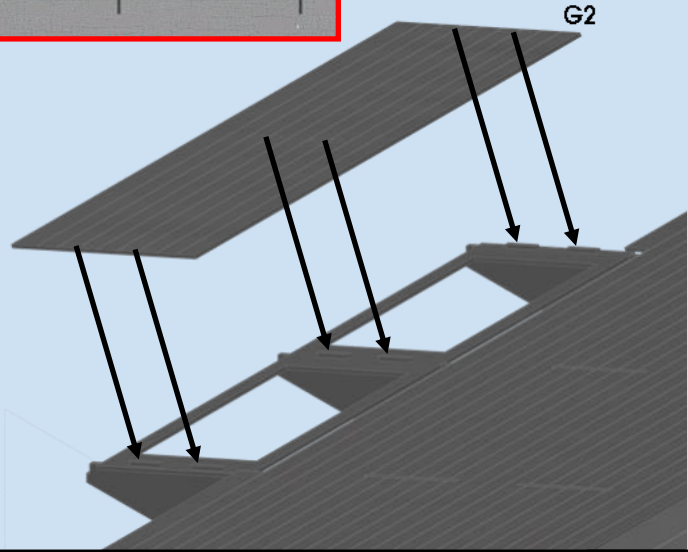

38

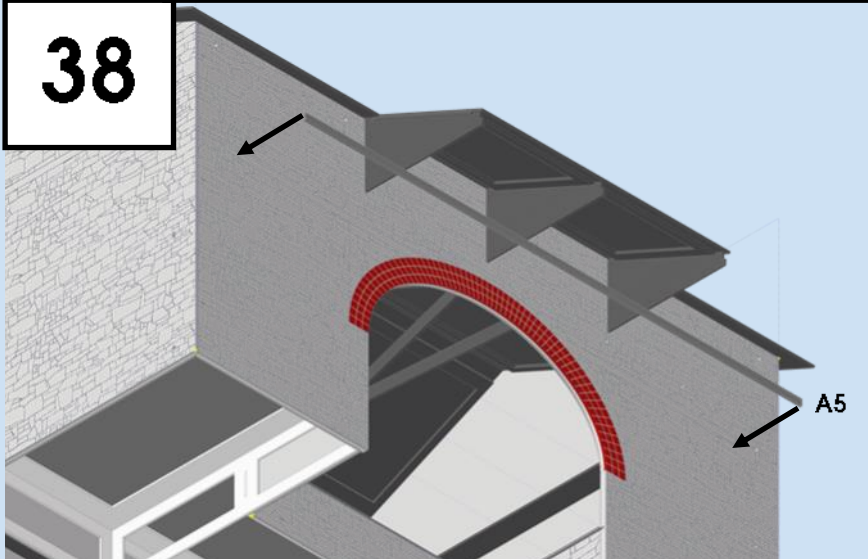

A5

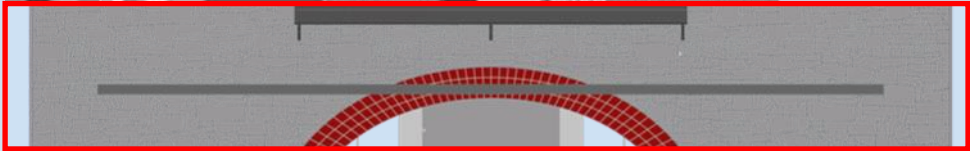

39

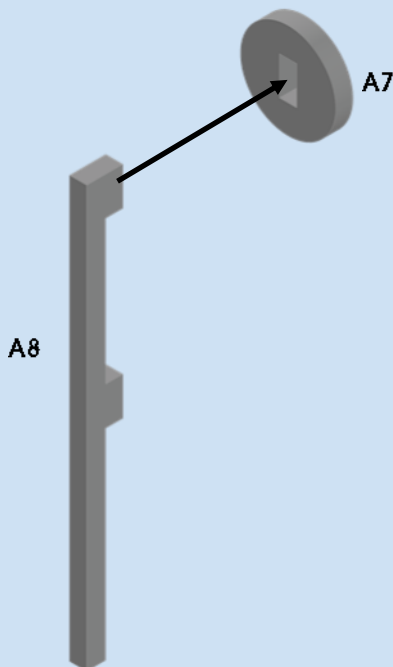

A7 & A8

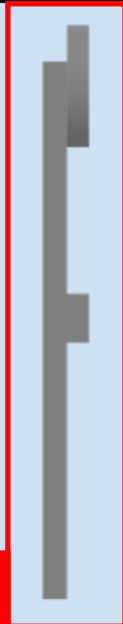

x4

40

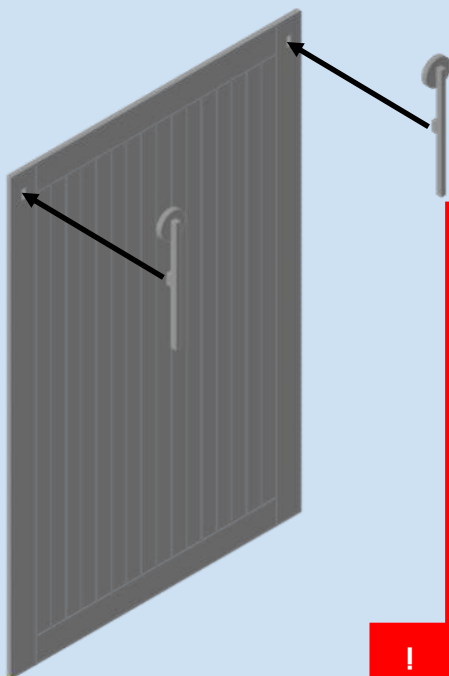

A6

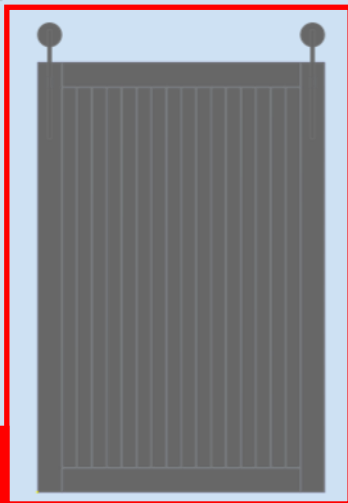

x2

41

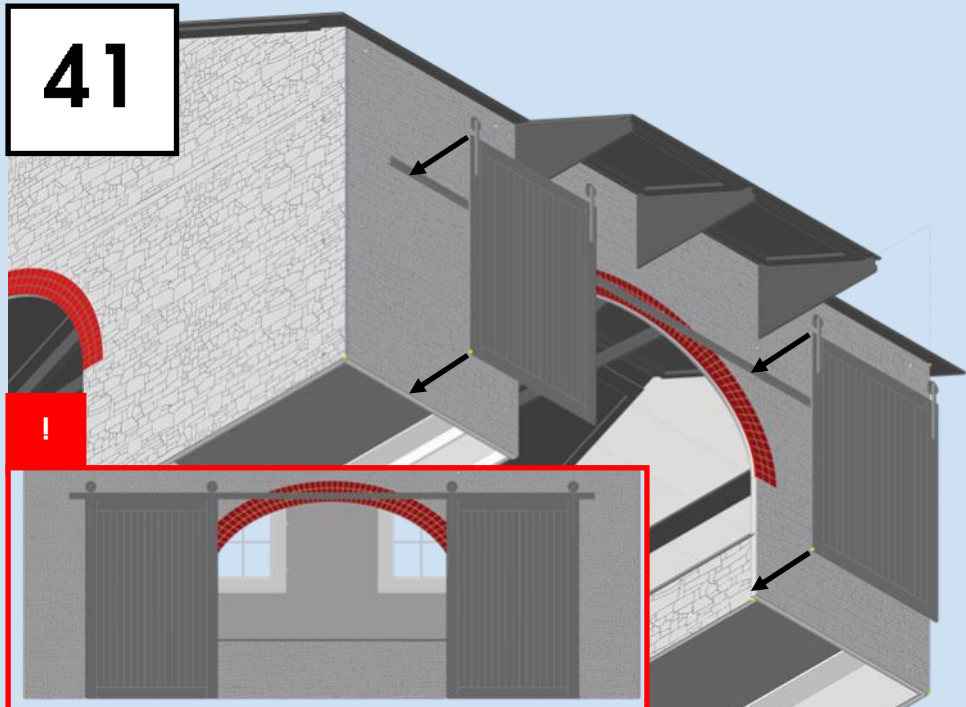

42

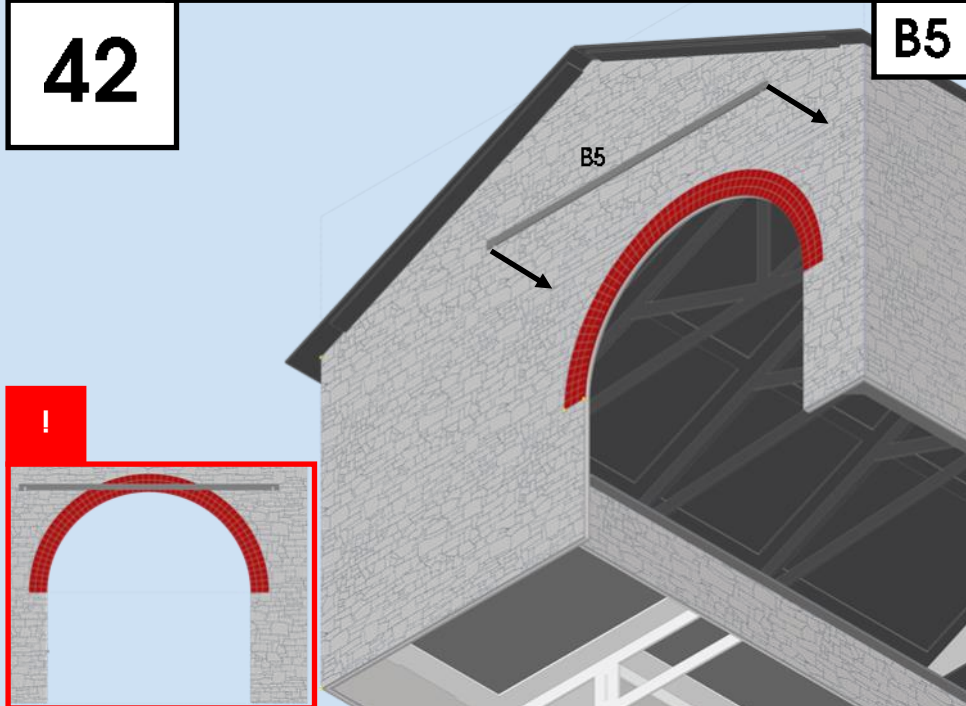

43

B6(x2)

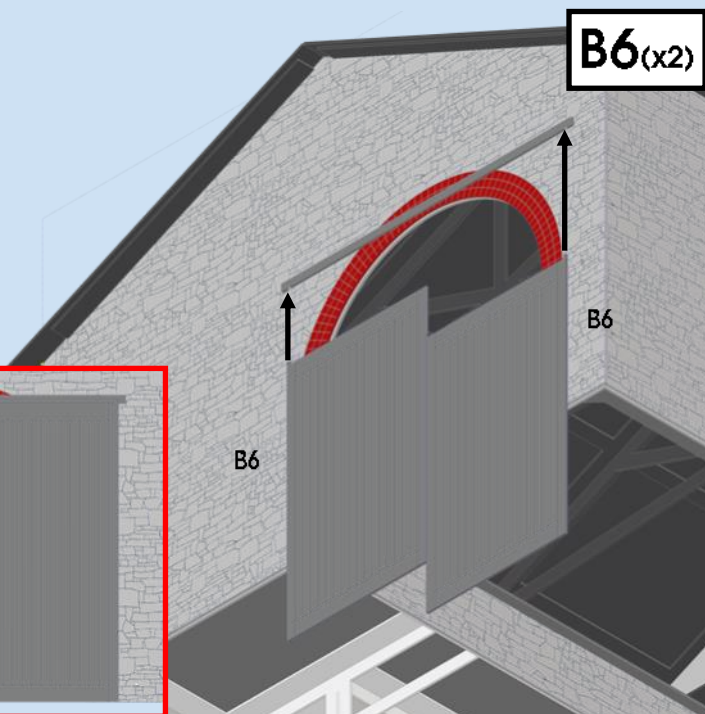

44

B7

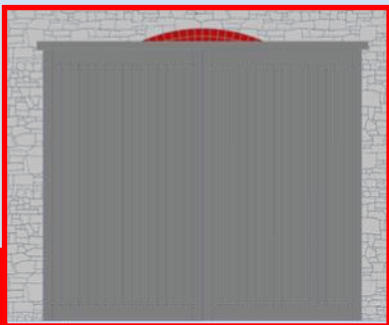
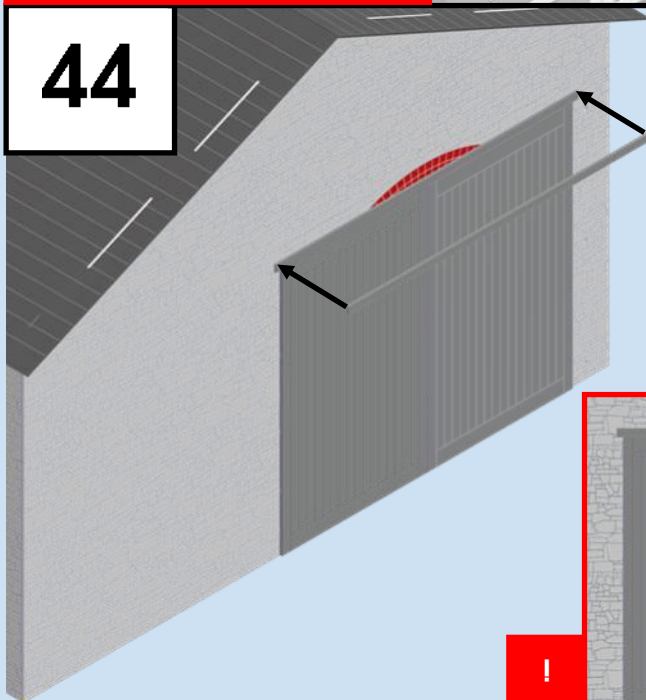

45

D5

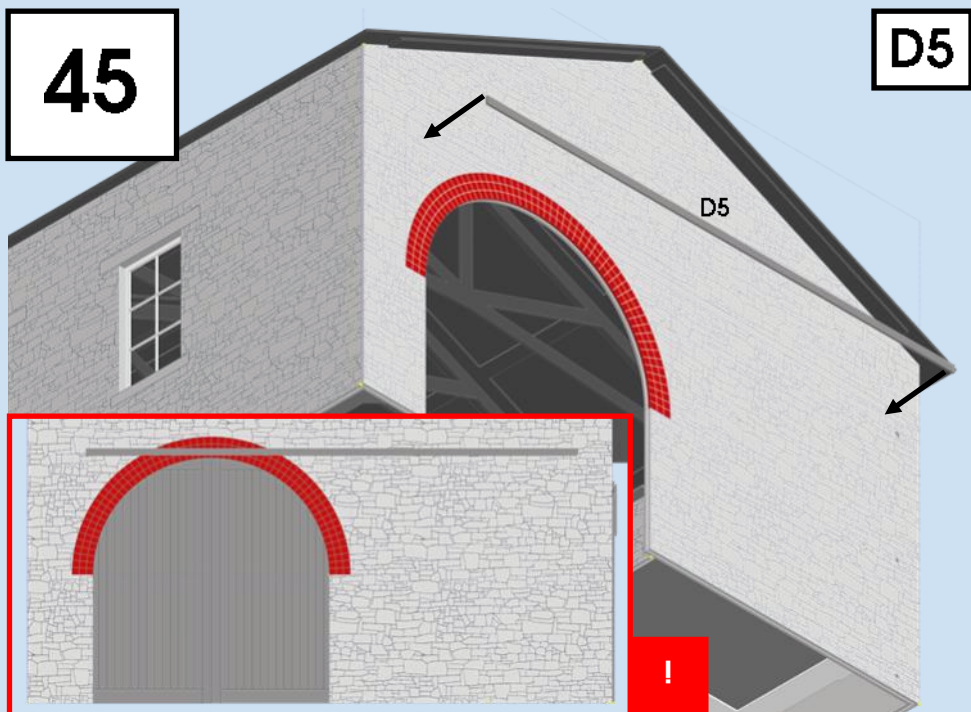

46

D7 & D8

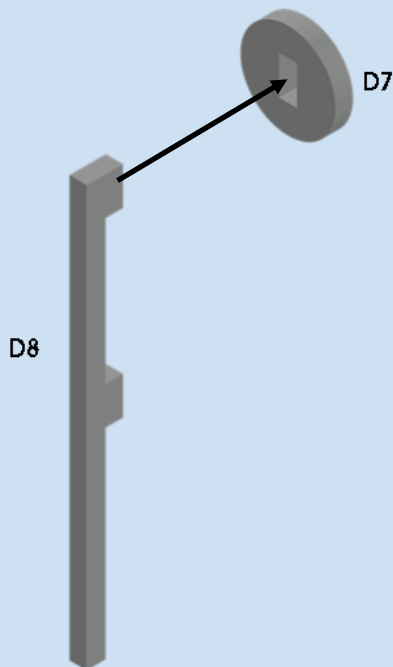

x4

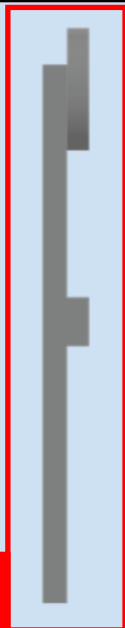

47

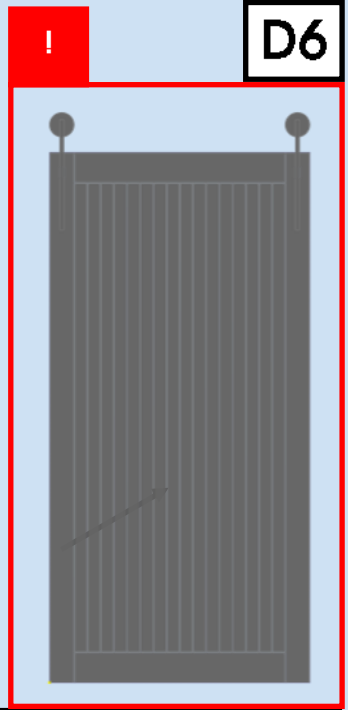
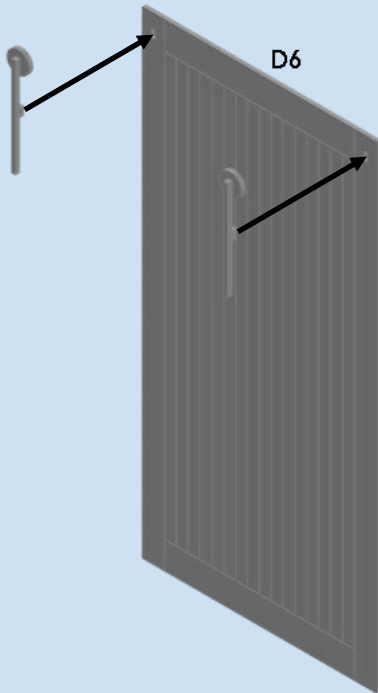

x2

48

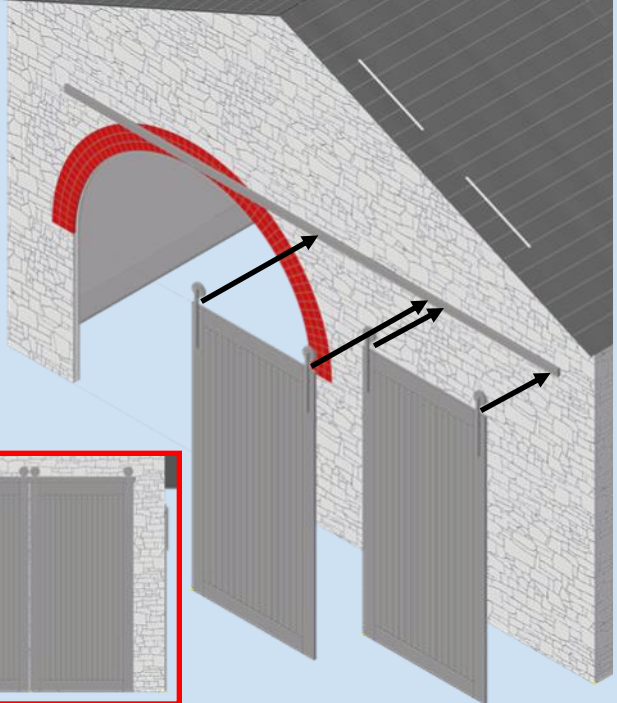

49

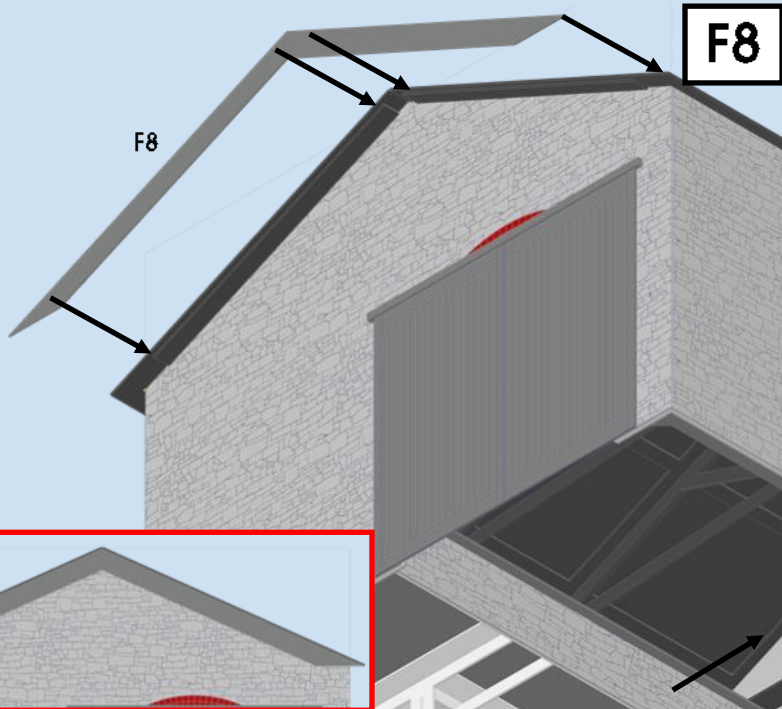

50

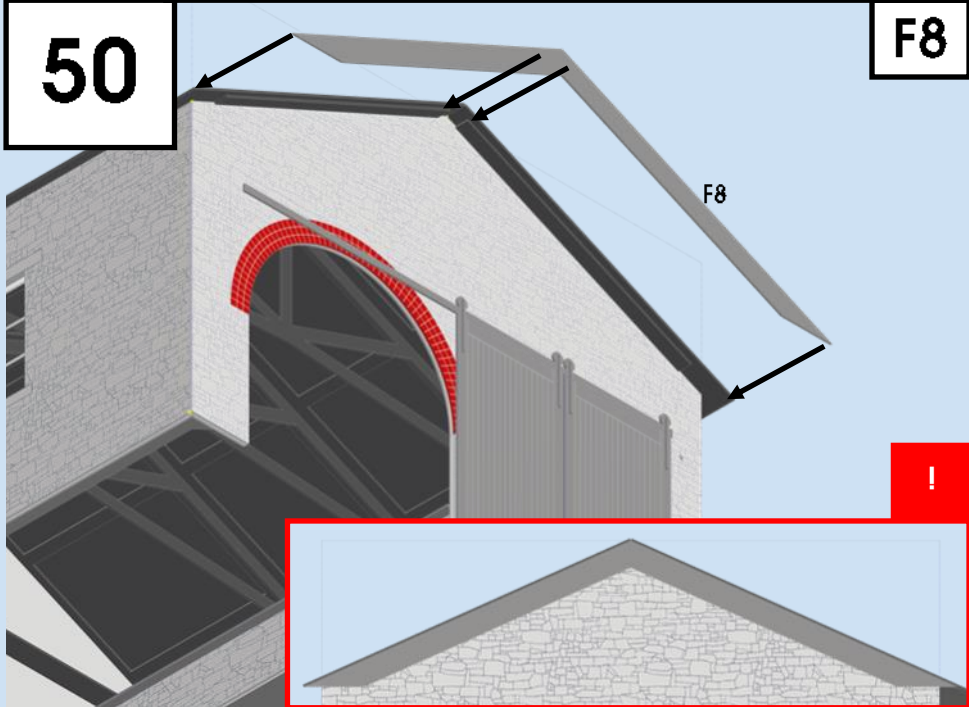

51

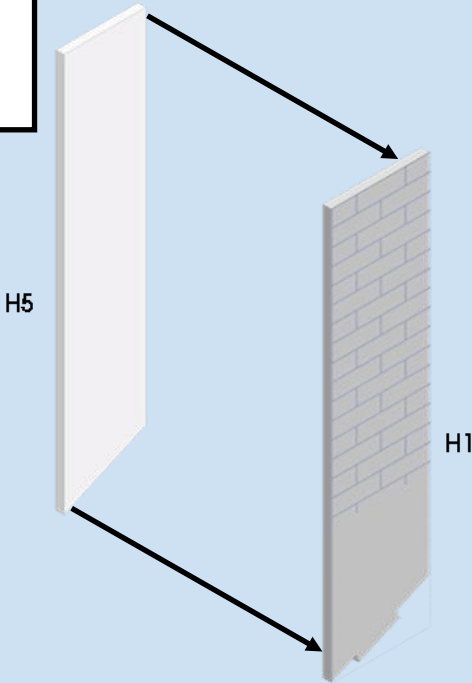

H1 & H5

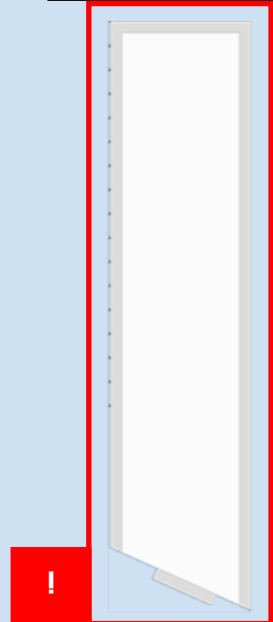

52

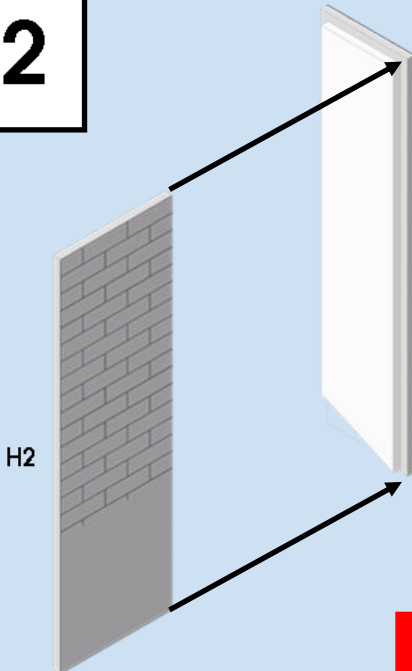

H2

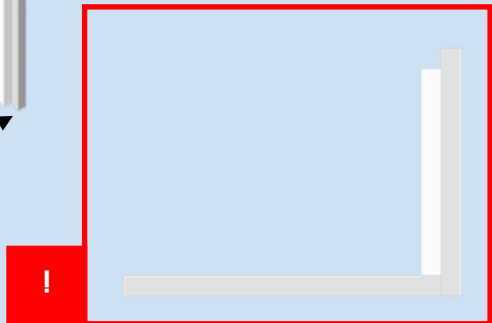

Proceed to Part 2