

Congratulations !

Your security camera is ready to use.
Thank you for choosing Qsee as your security partner.
Want to know more about Qsee products?



www.q-see.com

Qsee Network Video Recorder System Quick Start Guide

Contents

What's Include?	2
NVR Introduction	3
Camera Introduction	4
Ceiling Mount Guidelines for Camera	6
Set up NVR System	8
Connetion Diagram	10
Access the NVR via PC or Smartphone	11
Device Connection	12
Specification	13
Camera Installation Tips	14
FAQ's	15
Notification of Compliance	16

What's Include?

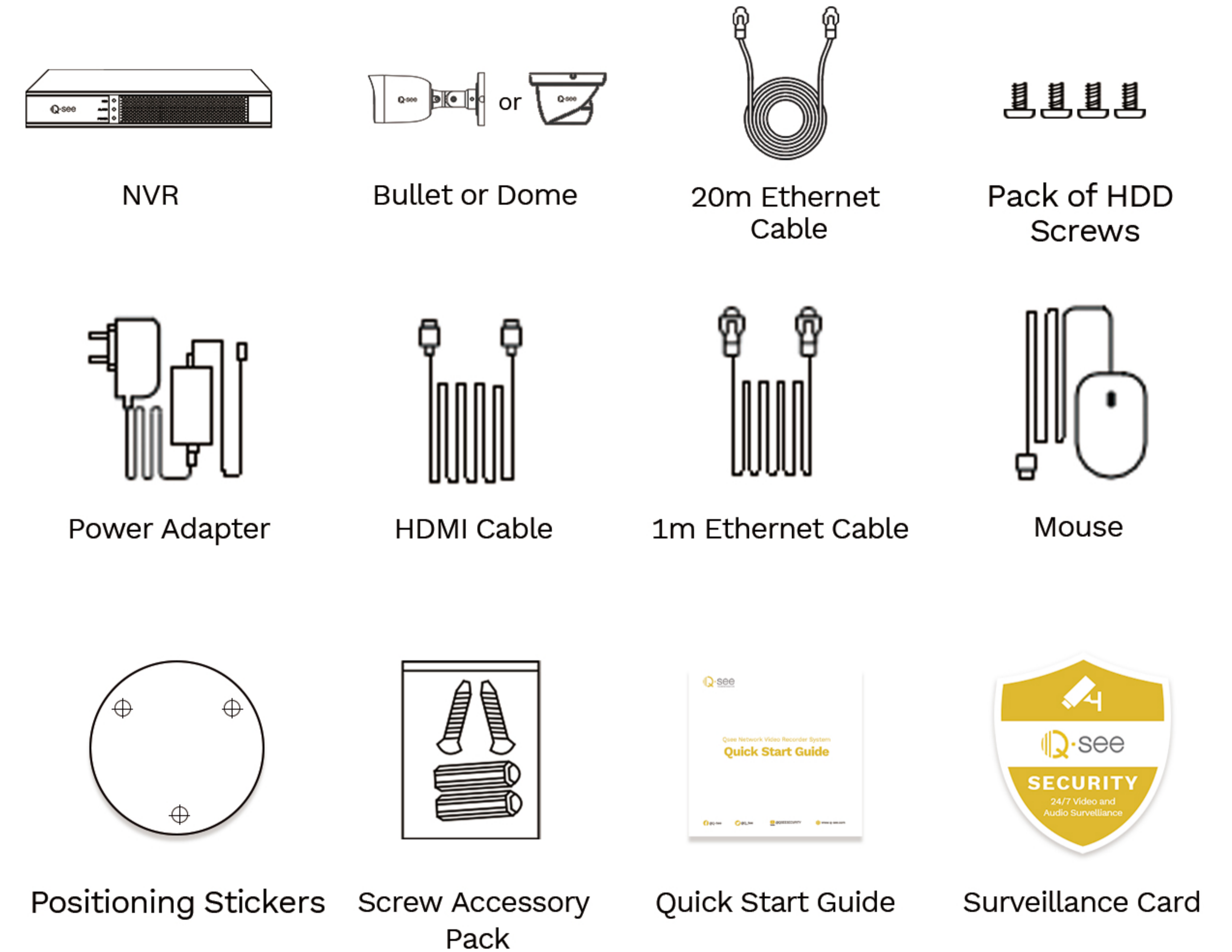

Note: -Pre-installed 1/2/3 TB hard disk or not in NVR depend on model No.
 -After unboxing, check that the console is intact and fully equipped.

NVR Introduction

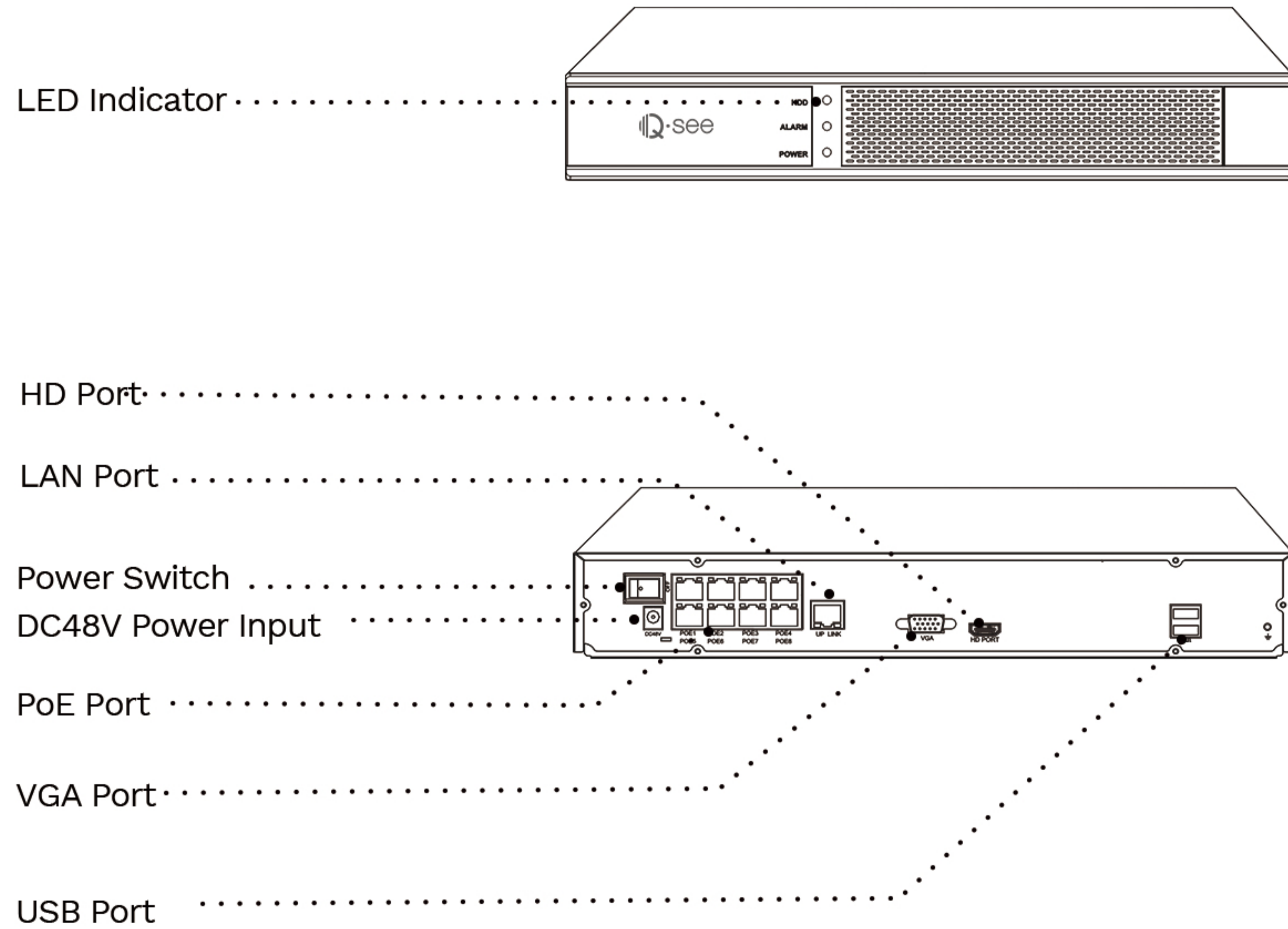

NOTE:-The actual appearance and components may vary with different model of product.

Camera Introduction

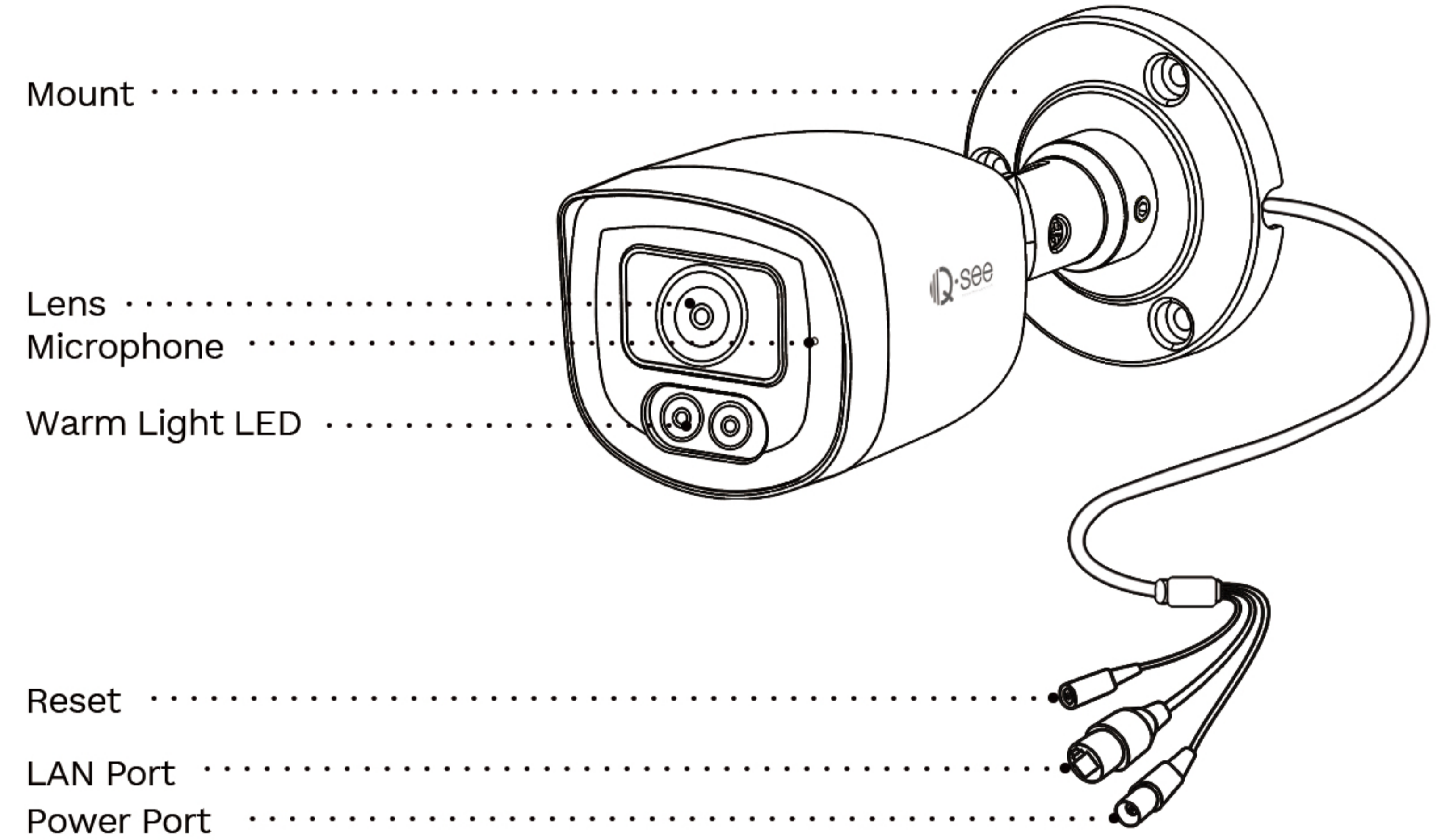

NOTE:-The actual appearance and components may vary with different model of product.

Ceiling Mount Guidelines for Camera

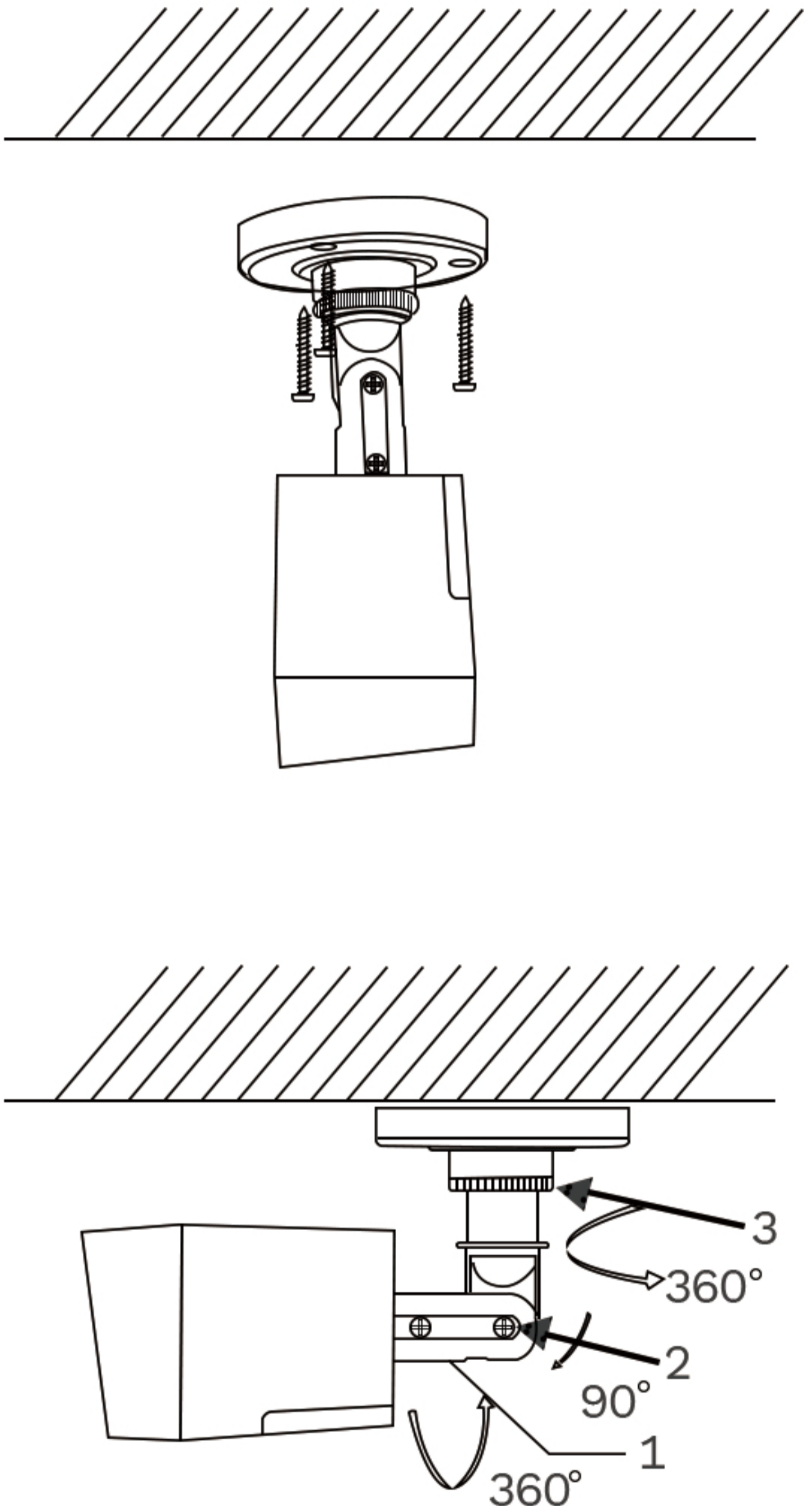
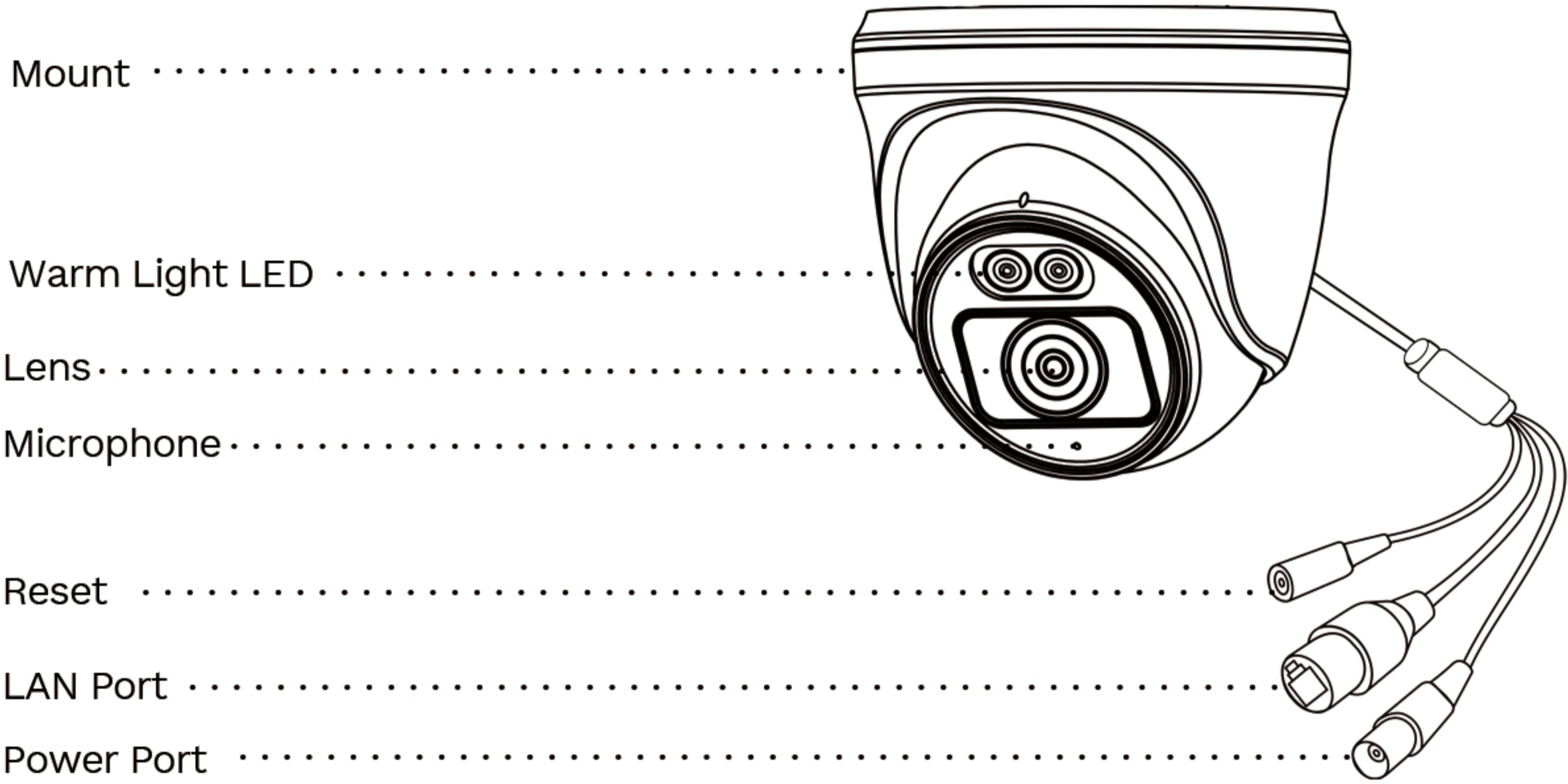

- 01/ Drill the screw holes in the ceiling according to the bracket.
- 02/ Connect the corresponding power cable and video cable.
- 03/ Fix the camera to the ceiling with the supplied screws.

- 04/ Adjust the surveillance angle
 - 1) Loosen No.3 with adjusting screw to adjust the panning position (0° ~ 360°).
 - 2) Tighten No.3 with adjusting screw.
 - 3) Loosen the No.2 with adjusting screw to adjust the tilting position (0° ~ 90°).
 - 4) Tighten No. 2 with adjusting screw.
 - 5) Loosen No.1 with adjusting screw to adjust the azimuth angle of the image (0° ~ 360).
 - 6) Tighten No.1 with adjusting screw.

NOTE:-The actual appearance and components may vary with different model of product.

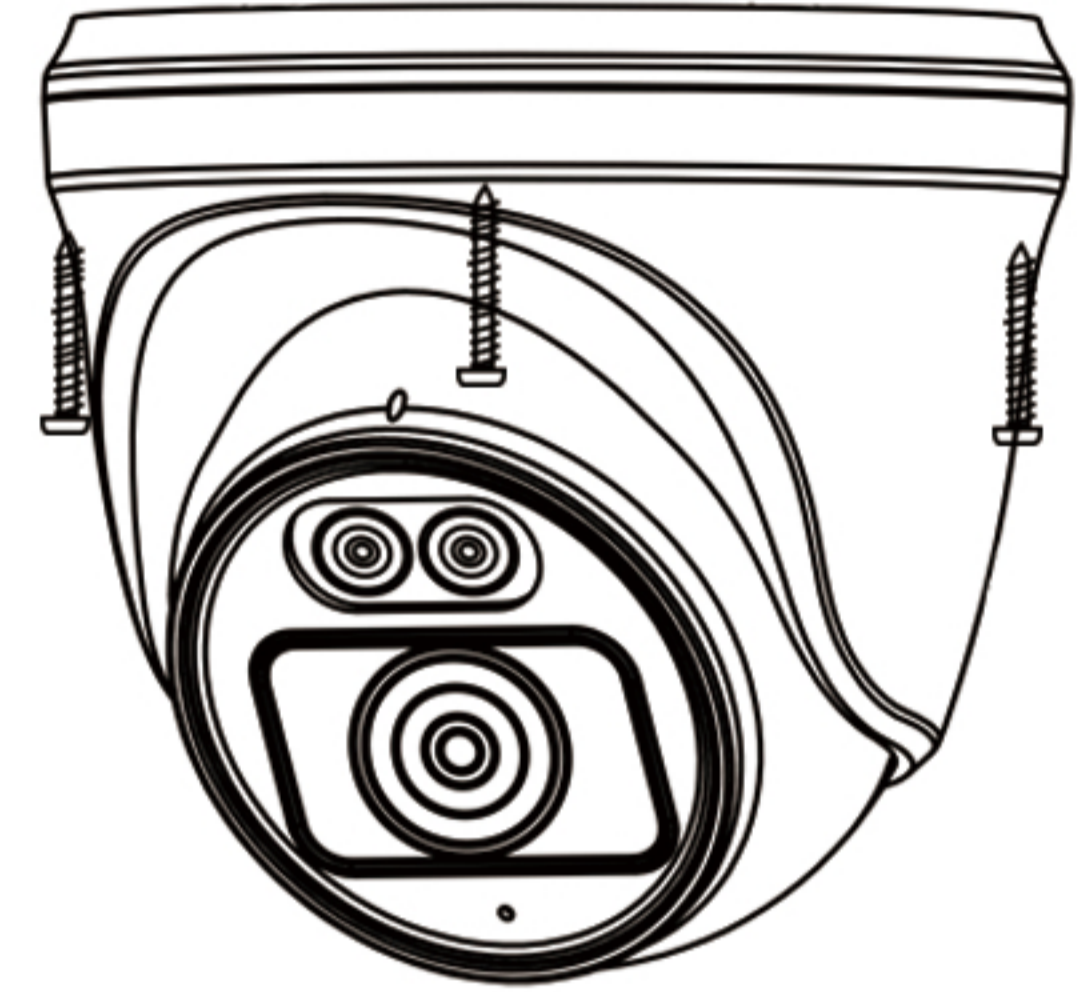

- 01/ Drill the screw holes in the ceiling according to the case.
- 02/ Connect the corresponding power cable and video cable.
- 03/ Fix the camera to the ceiling with the supplied screws.

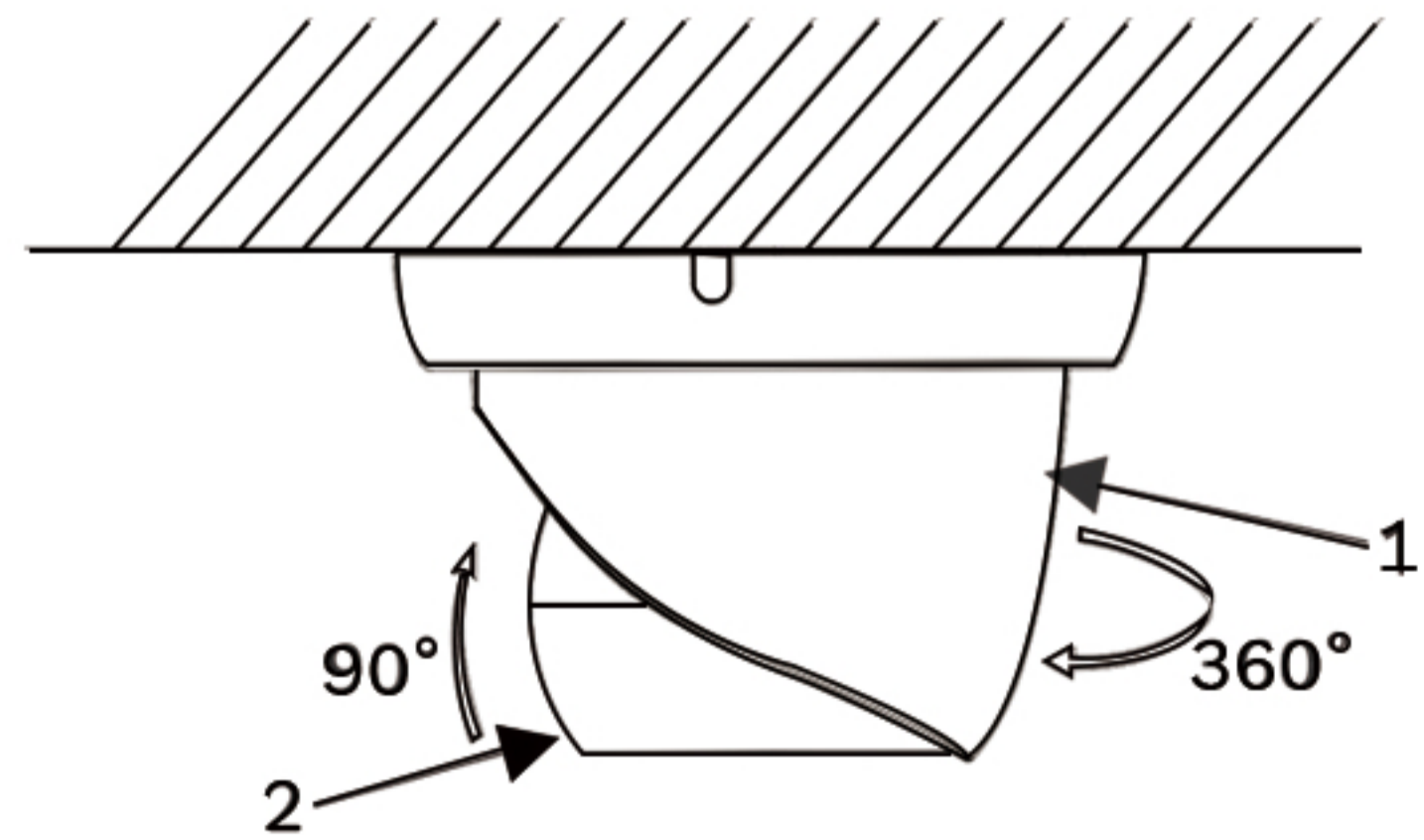

- 04/ Adjust the surveillance angle
 - 1) Adjust the panning position (0°~360°).
 - 2) Adjust the tilting position (0°~90°).

Set Up NVR System

Set up your device as per the quick set up guidance below

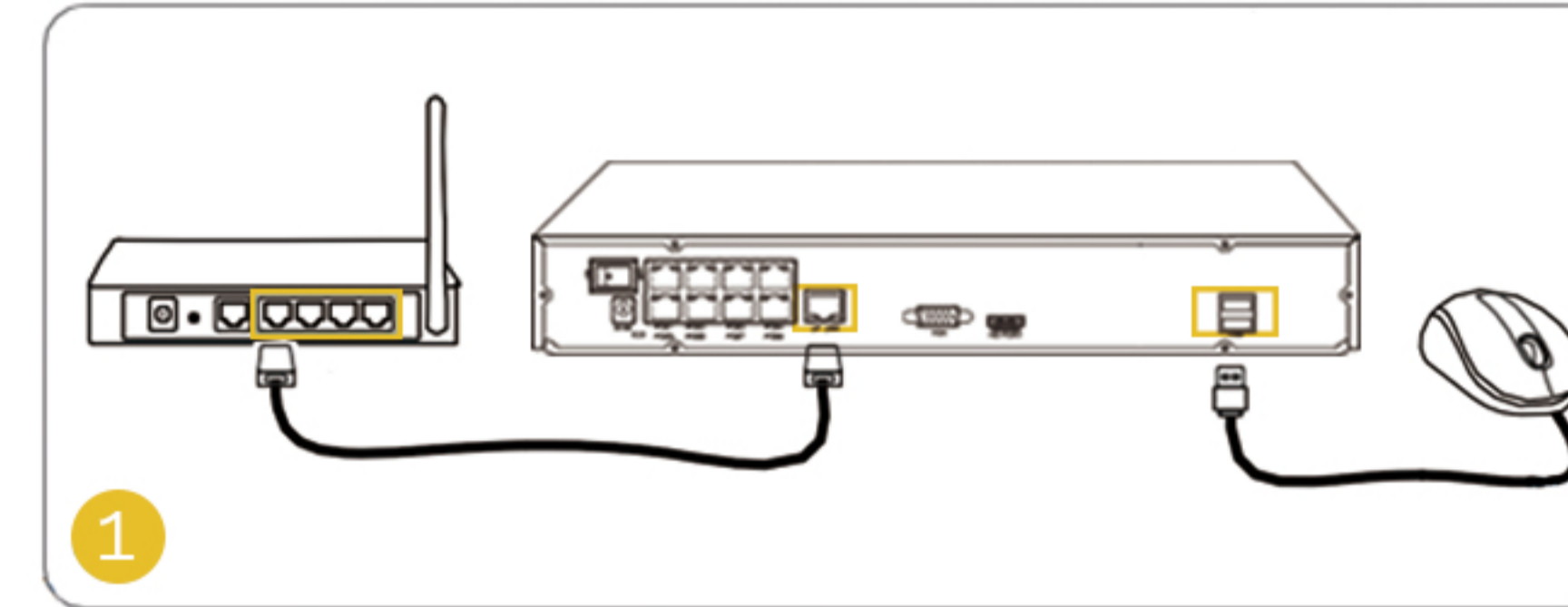

Connect the NVR (LAN port) to your router with an ethernet cable. Next, connect the mouse to the USB port of the NVR

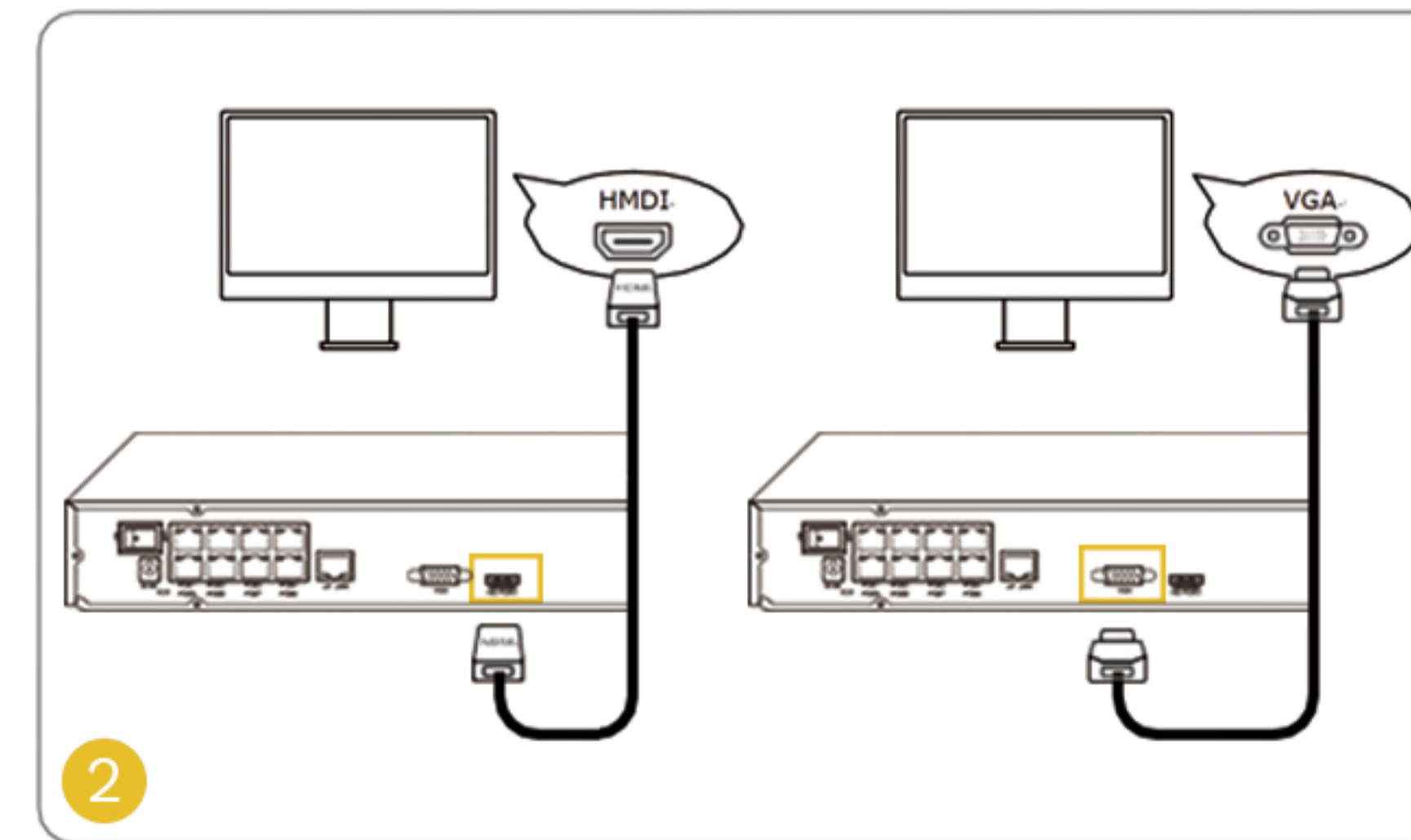

Connect the NVR to the monitor with a VGA or HDMI cable.
NOTE: There is no VGA cable included in the package.

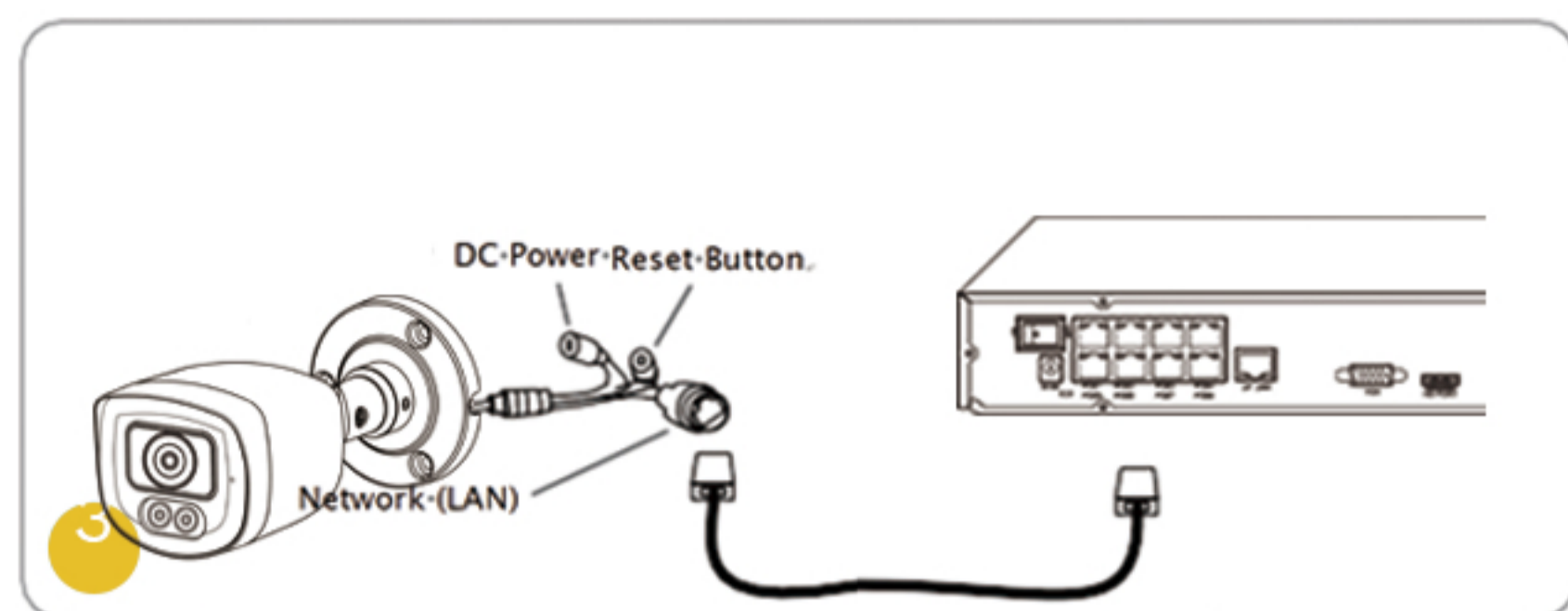

Connect the Camera to NVR with an ethernet cable.

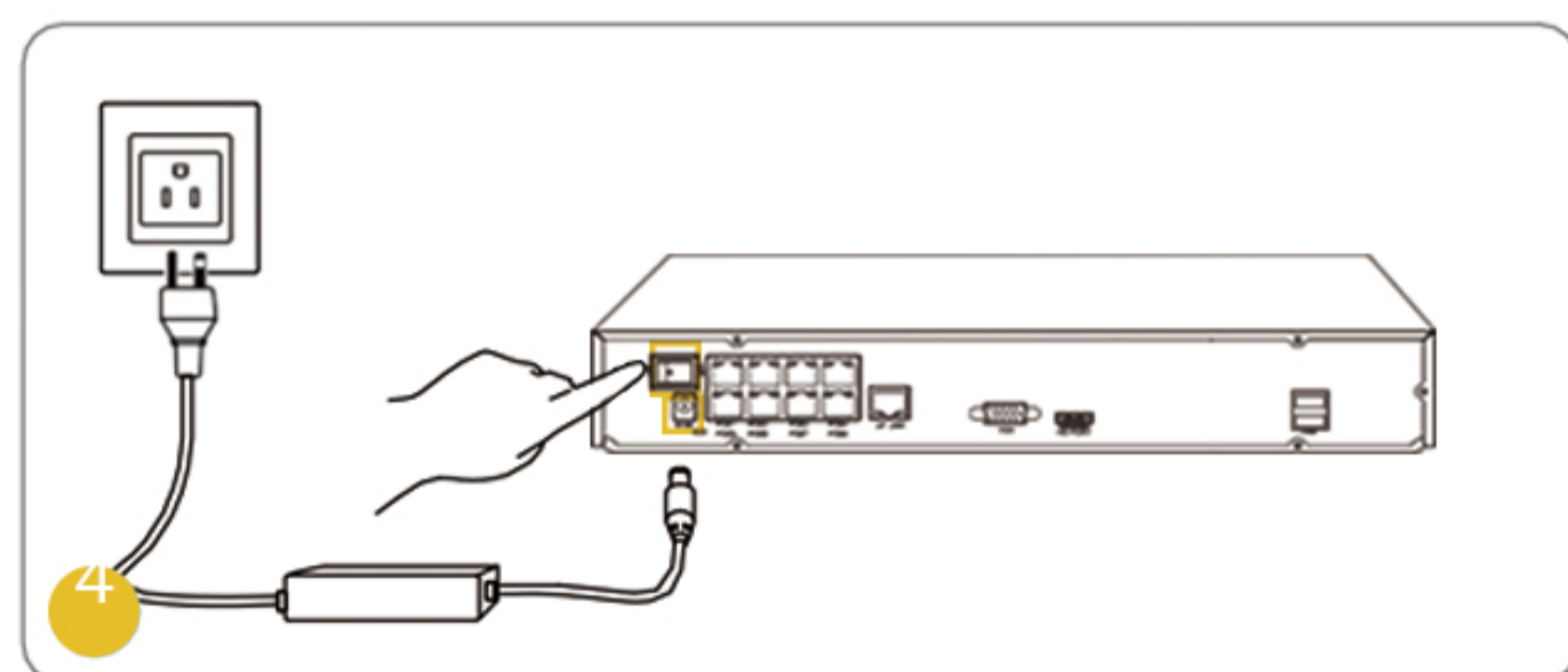

Connect the NVR to a power adapter and turn on power switch.

NOTE: Some Qsee WiFi cameras also work with Qsee NVR. For more information, visit www.q-see.com and learn more.

Connection Diagram

Do not install the camera near high voltage sources or other sources of electrical interference, otherwise the video signal may be poor.

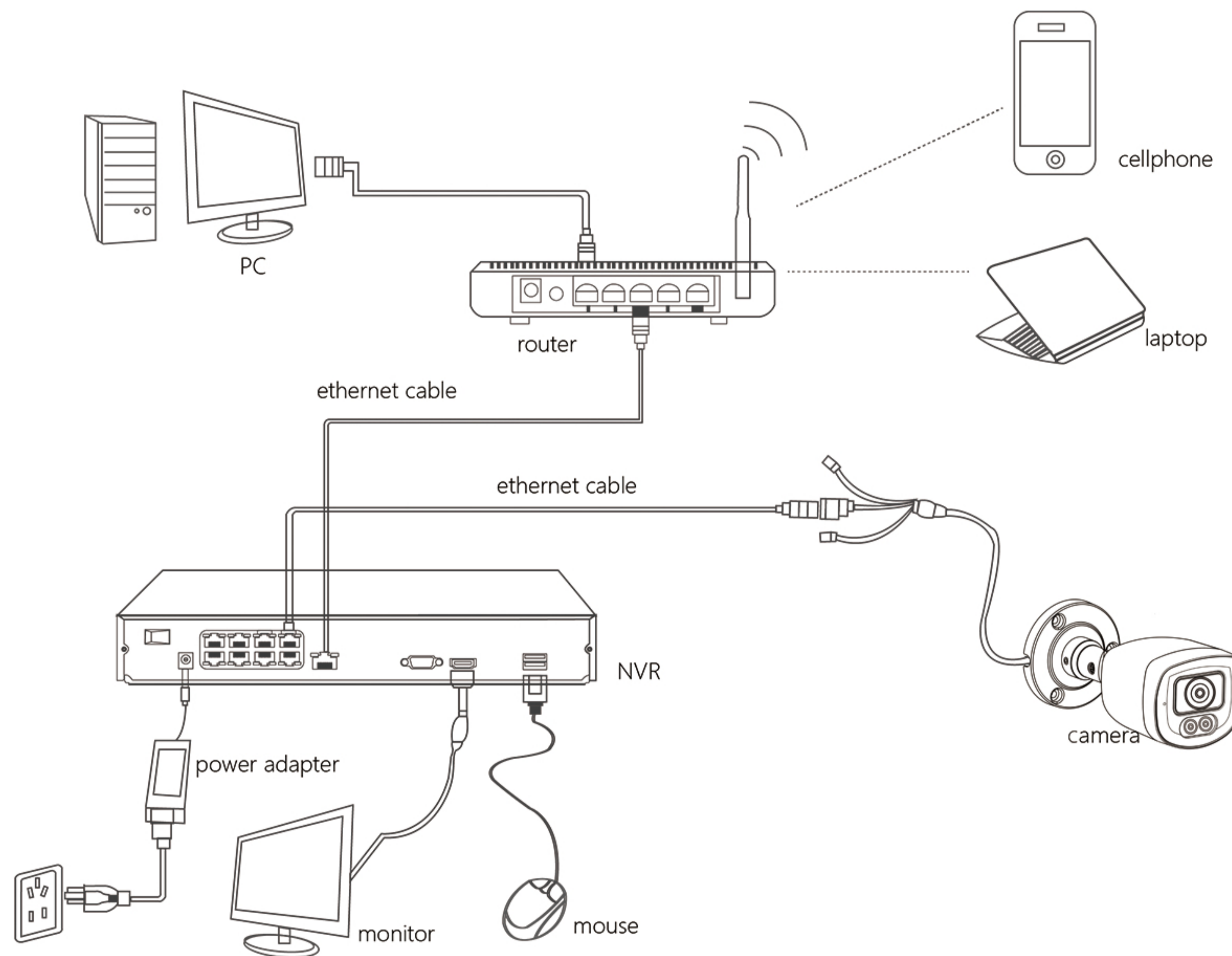

NOTE:-The above diagram is only for connection guidance, part of the accessories are not included in the box.

Access NVR Via PC or Smartphone

Download and launch the Qsee App or Client software and follow the instructions to access the NVR

•On PC

1. Copy the device IP Address and open it in your browser and follow the instructions to access remotely.
2. Download path: Go to www.q-see.com > Support > APP&Client download.

•On Smartphone

Scan to download the Qsee App.



Device Connection

A. Register and login your account

B. Click "+"

C. Select "Smart Camera" or select "NVR" and click Wired.

D. Scan the QR code on the NVR from the App and wait for the configuration.

NOTE:- If you are not able to find the QR code on NVR, click the Cloud ID number seen on the right top of the monitor screen and then scan the QR code to bind with App.

E. Live Preview

Learn more: www.q-see.com/pages/download

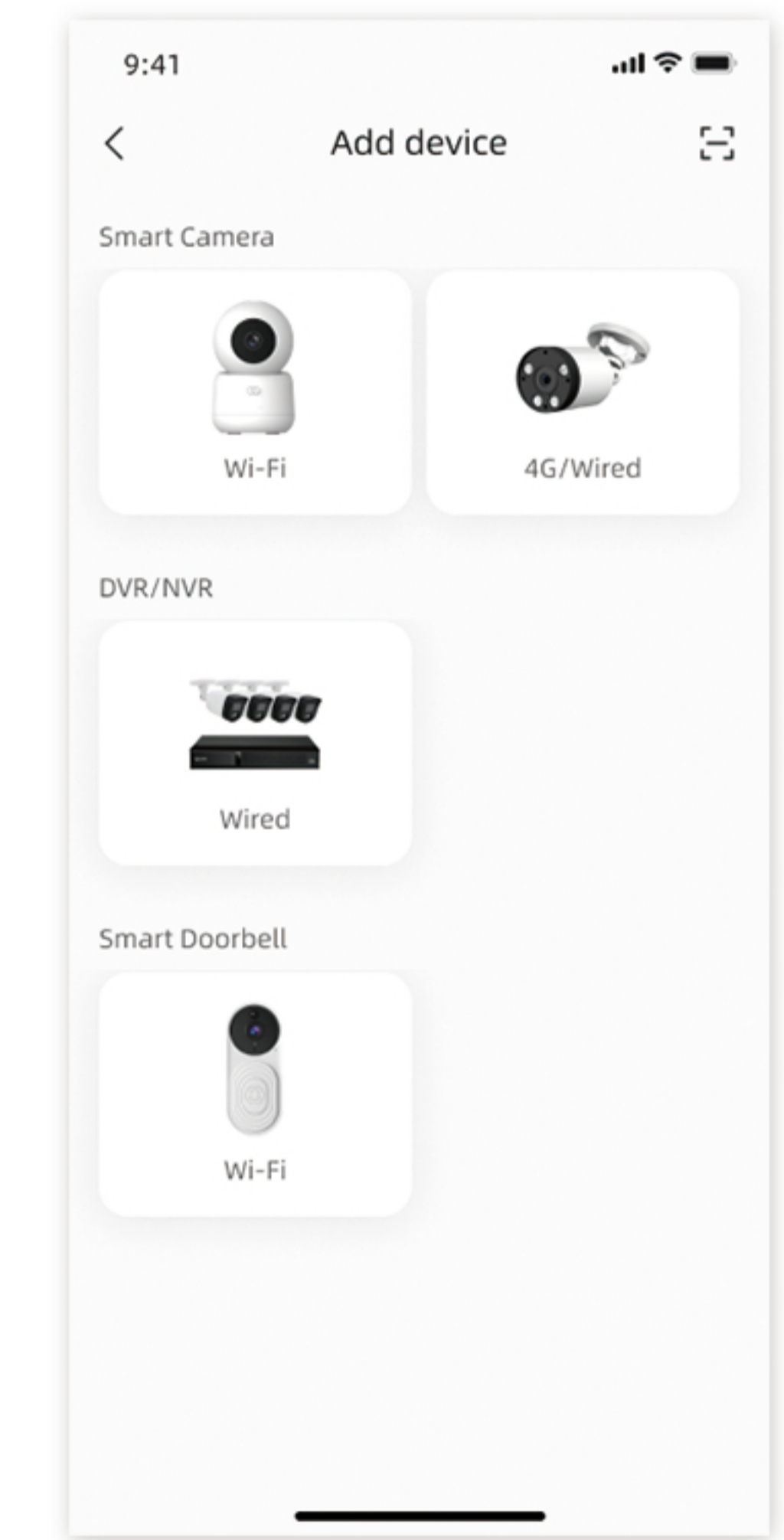
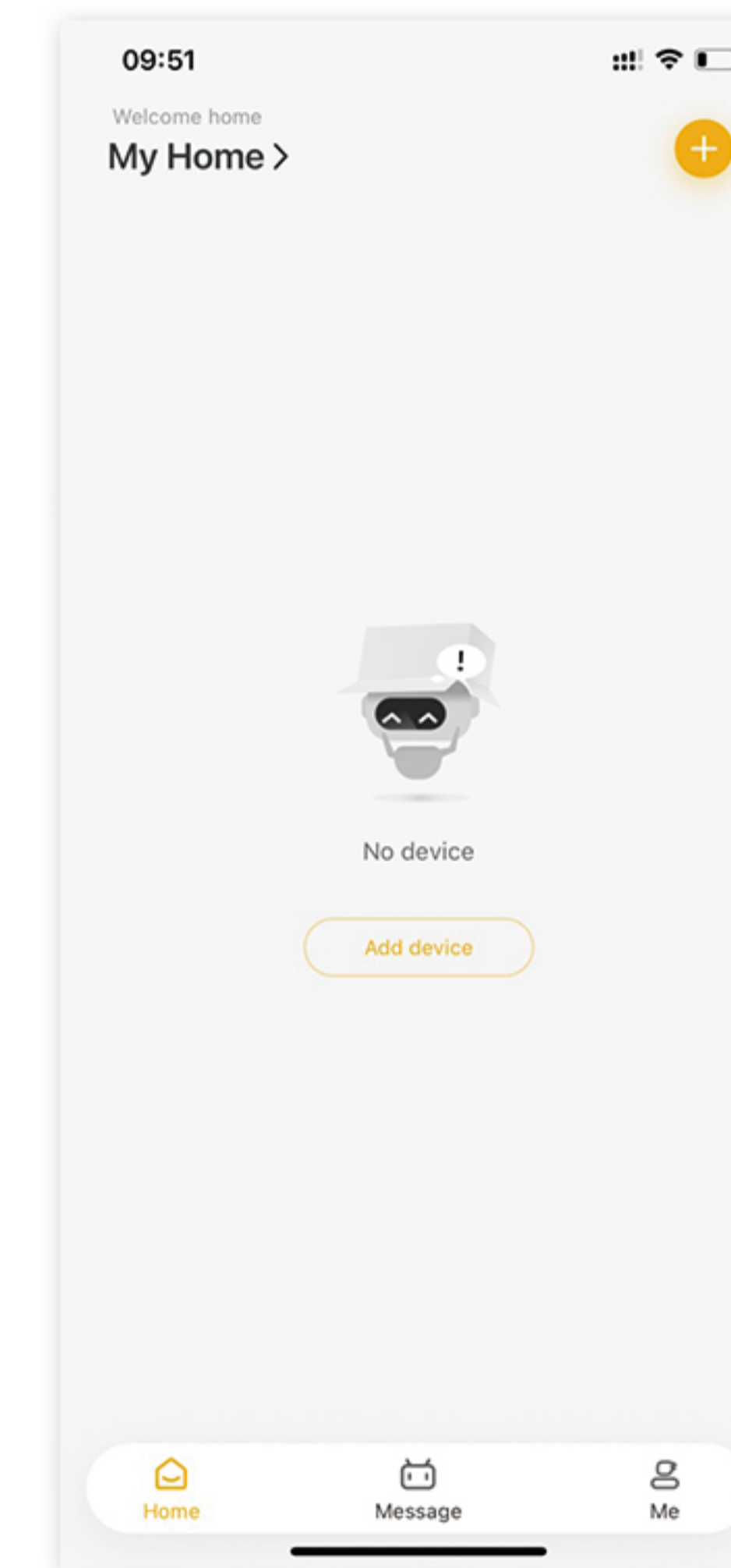
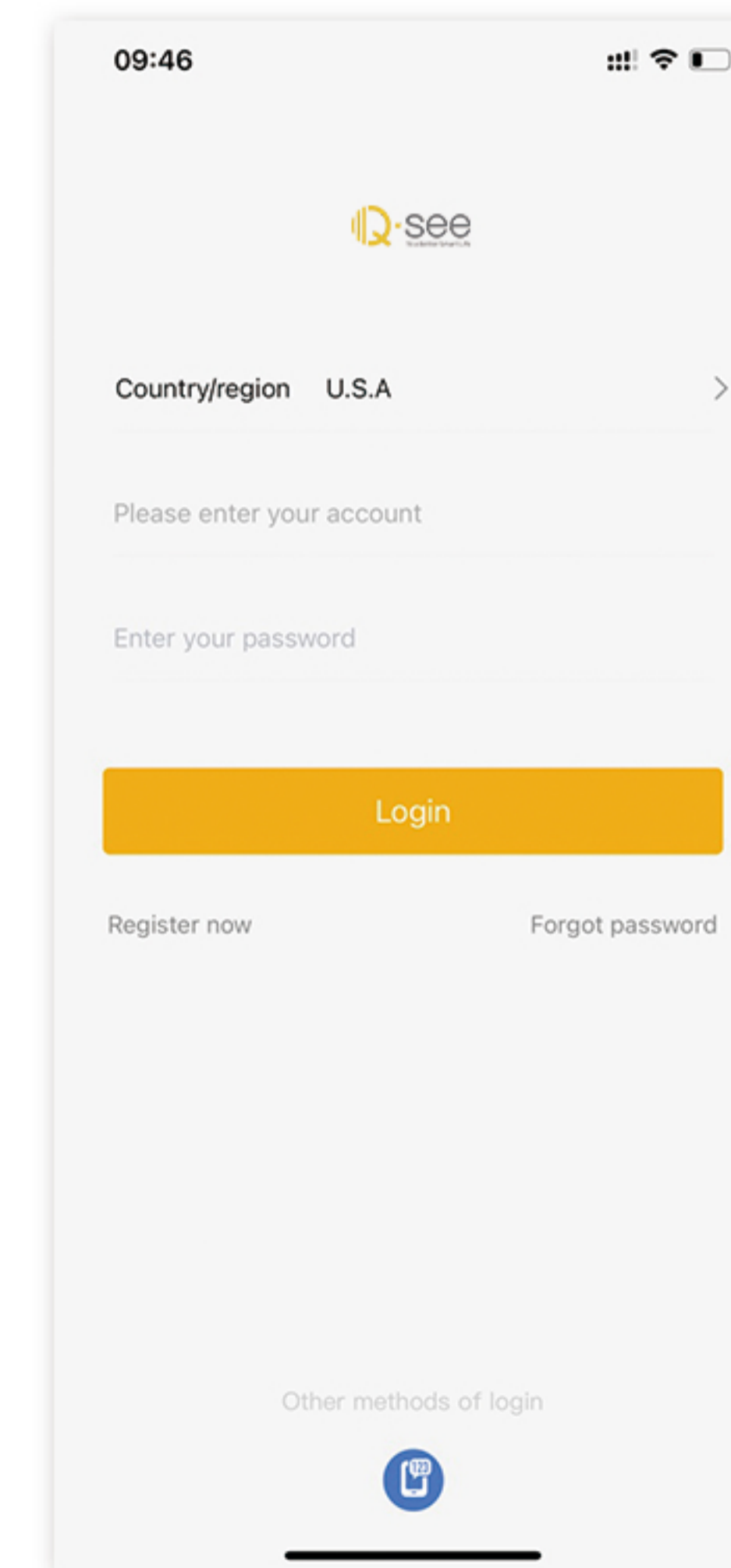

Specification

NVR

Decoding Resolution:	8MP/5MP/4MP/3MP/1080p/720p
----------------------	----------------------------

Operating temperature:	-10°C ~ 55°C (14 °F ~ 131 °F)
------------------------	-------------------------------

Dimensions:	255 x 225 x 42mm
-------------	------------------

Weight:	2.0kg
---------	-------

Camera

Night Vision:	20 Meters (65.6ft)
---------------	--------------------

Day/Night Mode:	Auto Switchover
-----------------	-----------------

Operating Temperature:	-20°C ~ 50°C(-4 °F ~ 122 °F)
------------------------	------------------------------

Operating Humidity:	10%~90%
---------------------	---------

Weather Resistance:	IP66(Plastic);IP67(Metal)
---------------------	---------------------------

Camera Installation Tips

- Do not point the camera towards a glass window, or it may result in poor image quality which can lead to miss some important details of what you care about.
- Do not face the camera towards any light sources.
- Do not place the camera in a shaded area and point it towards a well-lit area. Or it may result in poor image quality. To ensure best image quality, the lighting condition for both the camera and area of surveillance should be same.
- To ensure better image quality, it's recommended to clean the lens with a soft cloth from time to time.
- Make sure the power ports are not directly exposed to water or moisture and not blocked by dirt or other elements.
- With IP waterproof ratings, the camera can work properly under conditions like rain and snow. (it can't use for underwater surveillance).
- Do not install the camera at places where rain and snow hit the lens directly.
- High mounting positions work best since they keep the security camera out of reach of intruders, curious children or inquisitive pets.

If you encounter any troubles in product information, product installation and use, please email us at support@q-see.com or refer us to our website www.q-see.com

FAQ's

Q: No video output on the monitor/TV

If there's no video output on the monitor from Qsee NVR, please try the following solutions:

- TV/Monitor resolution should be match with NVR, at least 1080p or above.
- Make sure your NVR is powered on.
- Double check the HDMI/VGA Connection, or swap another cable or monitor to test.

Q: Failed to access the PoE NVR locally

If you failed to access the PoE NVR locally via mobile phone or PC, please try the following solutions:

- Make sure to connect the NVR (LAN port) to the router with a network cable.
- Swap another ethernet cable or plug the NVR to other ports on the router.
- Go to Mainmenu>System>Restore>click Select all and ok button and restart by manual.

Q: Failed to access the PoE NVR remotely

If you failed to access the PoE NVR remotely via mobile phone or PC, Please try the following:

- Make sure you can locally access this NVR system.
- Go to the path : Main Menu>Network>Network Settings>DHCP Enable and make sure that DHCP Enable is selected.
- Please connect your phone or PC under the same network (LAN) of your NVR and see if you can visit any website to verify whether there is internet access available.
- Please reboot your NVR and router and try again.

Notification of Compliance

FCC Statement

This device complies with Part 15 of FCC rules. Operation is subject to the condition that this device may not cause harmful interference.

NOTE:- This equipment has been tested and found to comply with the limits for a class B digital device, pursuant to part 15 of the FCC rules. These limits are designed to provide reasonable protection against harmful interference in a residential installation.

CE Declaration

Qsee declares that this device in compliance with essential requirements and other relevant provisions of EMC directive 2014/30/EU.

RoHS Compliance declaration

Qsee products delivered to our customers confirm to the RoHS requirements, in which six banned substances are not detected or are under the limitation. The Restriction of Hazardous Substances Directive (EU) 2015/863 and (EU)2017/2102 amending Annex II to Directive 2011/65/EU. This declaration is based on Qsee's understanding of the RoHS directive and knowledge of the materials that go into products.

Warranty

This product comes with a 2-year warranty, under certain conditions. Learn more :www.q-see.com/policies/refund-policy

NOTE:- If you are not satisfied with the new Qsee product purchase, we suggest you to reset the camera and return it under specific conditions.

Terms and Privacy

Use of the product is subject to your agreement to the terms of service and privacy policy at www.q-see.com. Keep out of reach of children.

End User License Agreement

By using the product software that is embedded in the Qsee product, you agree to the terms of this end user license agreement between you and Qsee. Learn more: www.q-see.com/policies/terms-of-service

Technical Support

If you need any technical help, please visit our official support site and contact our support team before returning the products.

Email: support@q-see.com

Web: www.q-see.com