

## Congratulations !

Your security camera is ready to use.  
Thank you for choosing Qsee as your security partner.  
Want to know more about Qsee products?



<http://www.q-see.com/>

# Qsee Network Video Recorder Quick Start Guide

## Contents

|                                       |    |
|---------------------------------------|----|
| What's Include? .....                 | 2  |
| NVR Introduction .....                | 3  |
| Set up NVR .....                      | 4  |
| Connetion Diagram .....               | 6  |
| NVR Setting .....                     | 7  |
| Access NVR Via PC or Smartphone ..... | 9  |
| Device Connection .....               | 10 |
| Specification .....                   | 11 |
| FAQ's .....                           | 12 |
| Notification of Compliance .....      | 13 |

## What's Include?



NVR

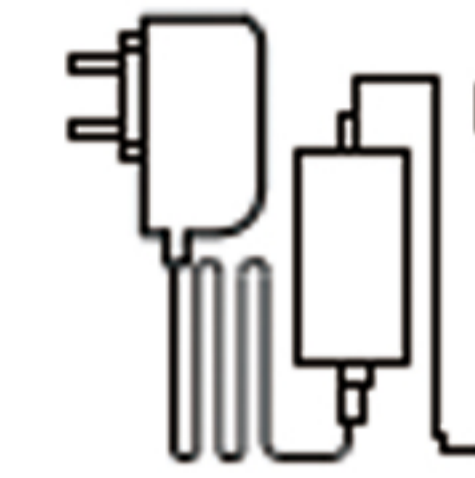

NVR  
Power Adapter



HDMI Cable



Ethernet Cable



USB Mouse



Quick Start Guide



Pack of HDD Screws

**Note:** -Pre-installed 1/2/3 TB hard disk or not in NVR depend on model No.

-After unboxing, check that the console is intact and fully equipped.

## NVR Introduction

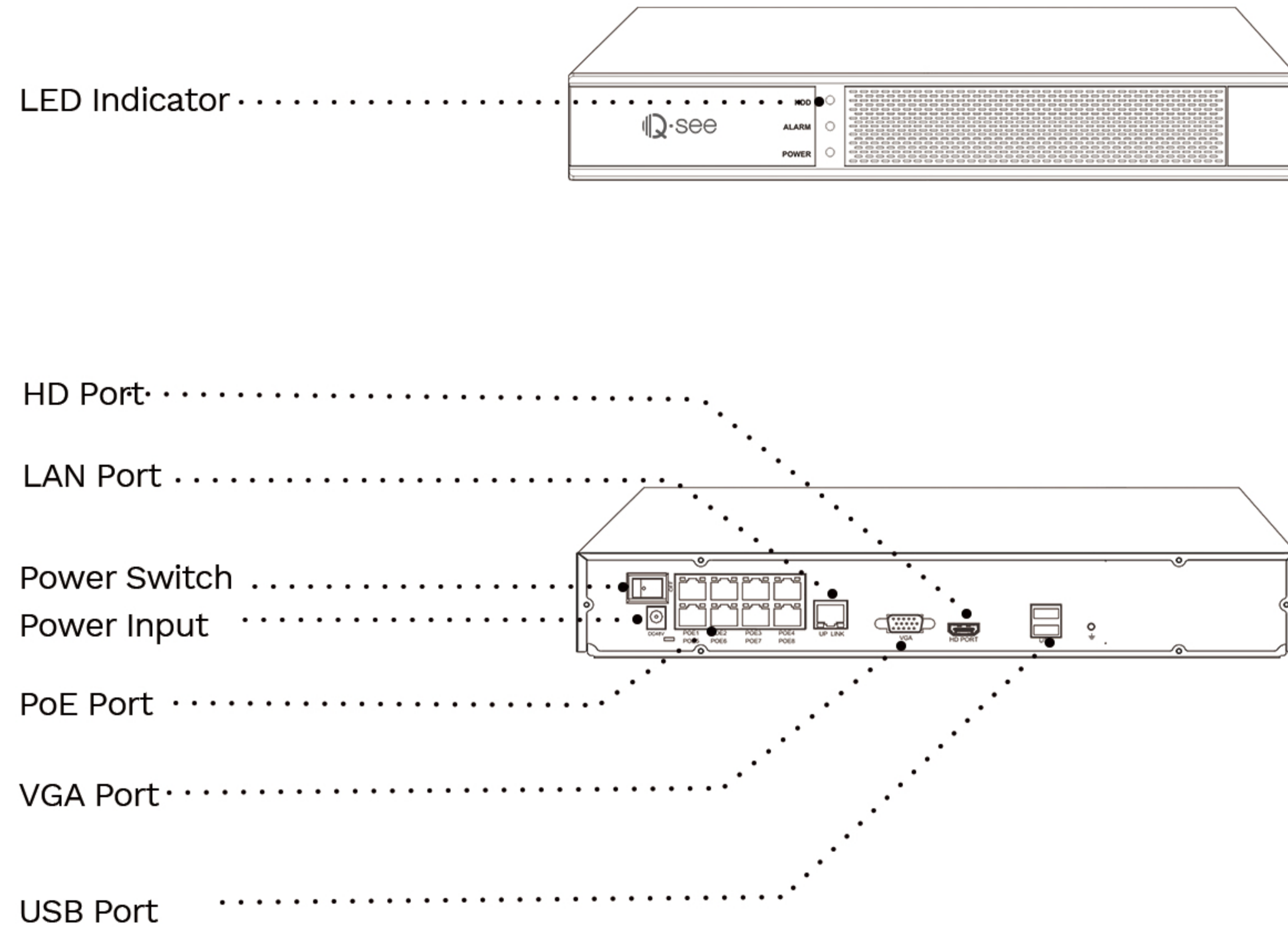

**NOTE:** After unboxing, check that the console is intact and fully equipped.

## Set Up NVR

Set up your device as per the quick set up guidance below

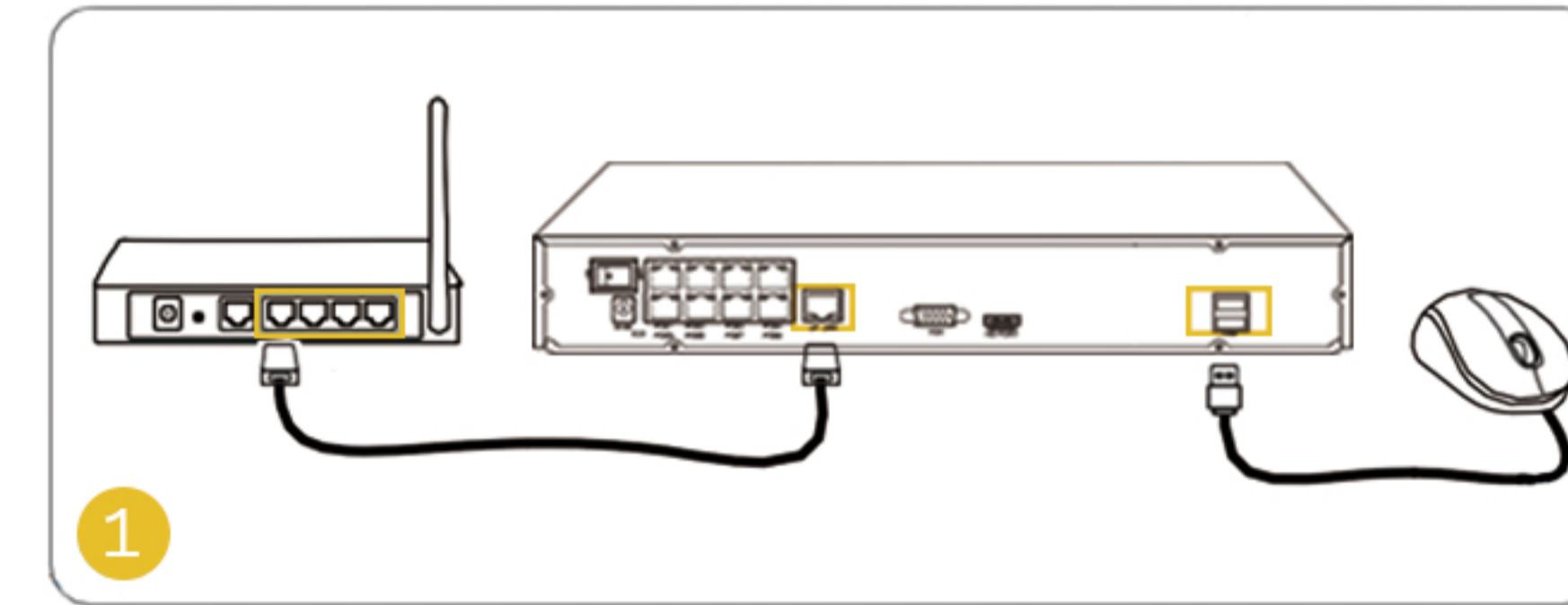

Connect the NVR (LAN port) to your router with an ethernet cable. Next, connect the mouse to the USB port of the NVR

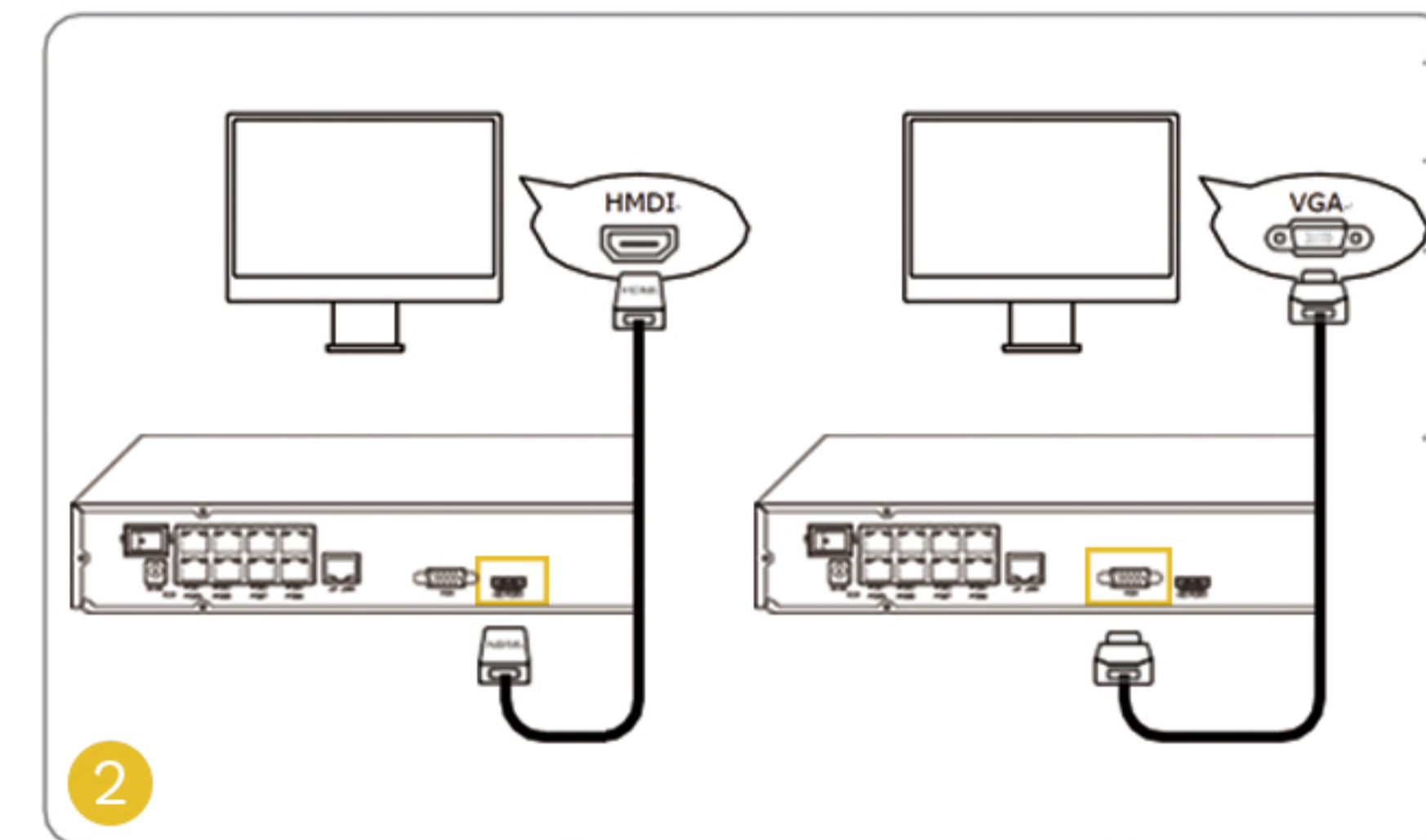

Connect the NVR to the monitor with a VGA or HDMI cable.  
**NOTE:** There is no VGA cable included in the package.

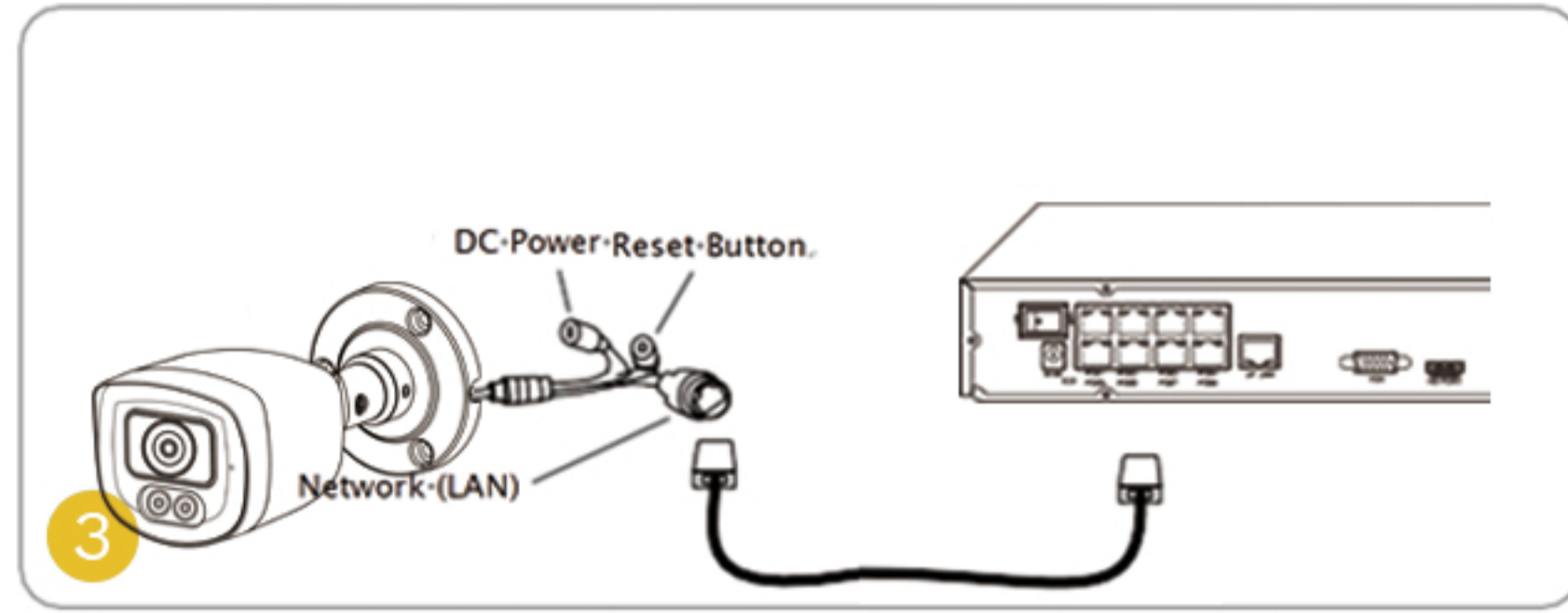

Connect the Camera to NVR with an ethernet cable.

**NOTE:** There is no camera included in the package.

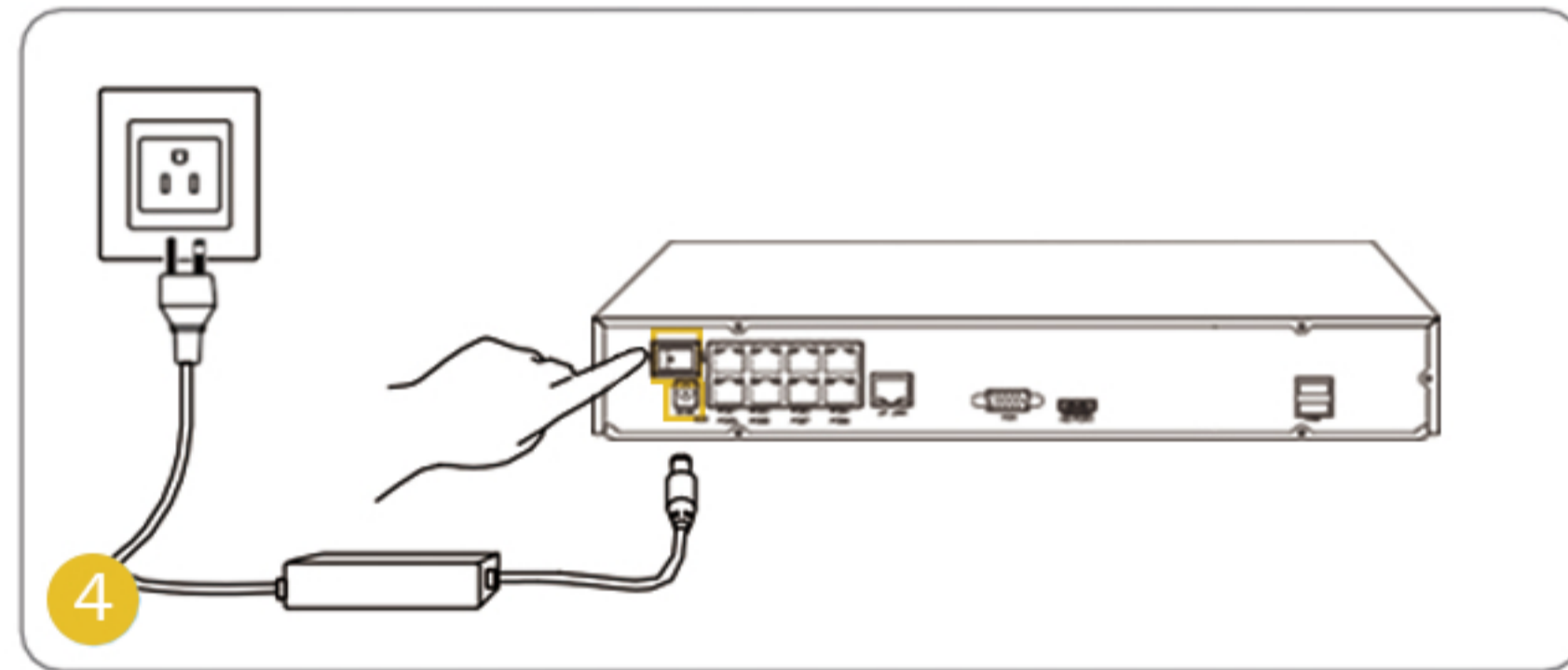

Connect the NVR to a power adapter and turn on power switch.

**NOTE:** Some Qsee WiFi cameras also work with Qsee NVR. For more information, visit [www.q-see.com](http://www.q-see.com) and learn more.

## Connection Diagram

Do not install the camera near high voltage sources or other sources of electrical interference, otherwise the video signal may be poor.

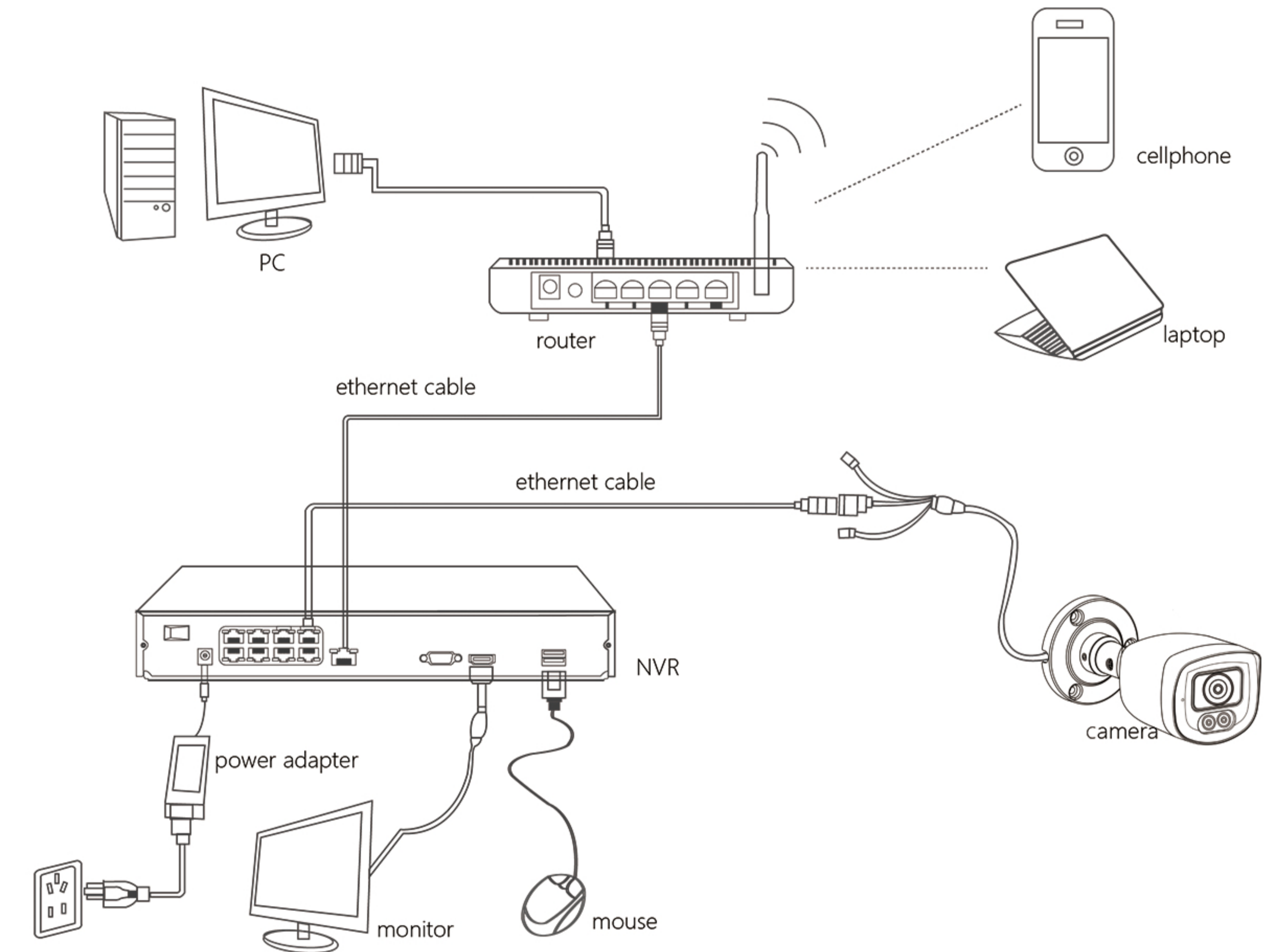

**NOTE:** The above diagram is only for connection guidance, part of the accessories are not included in the box.

## NVR Setting

-Login and follow the instructions

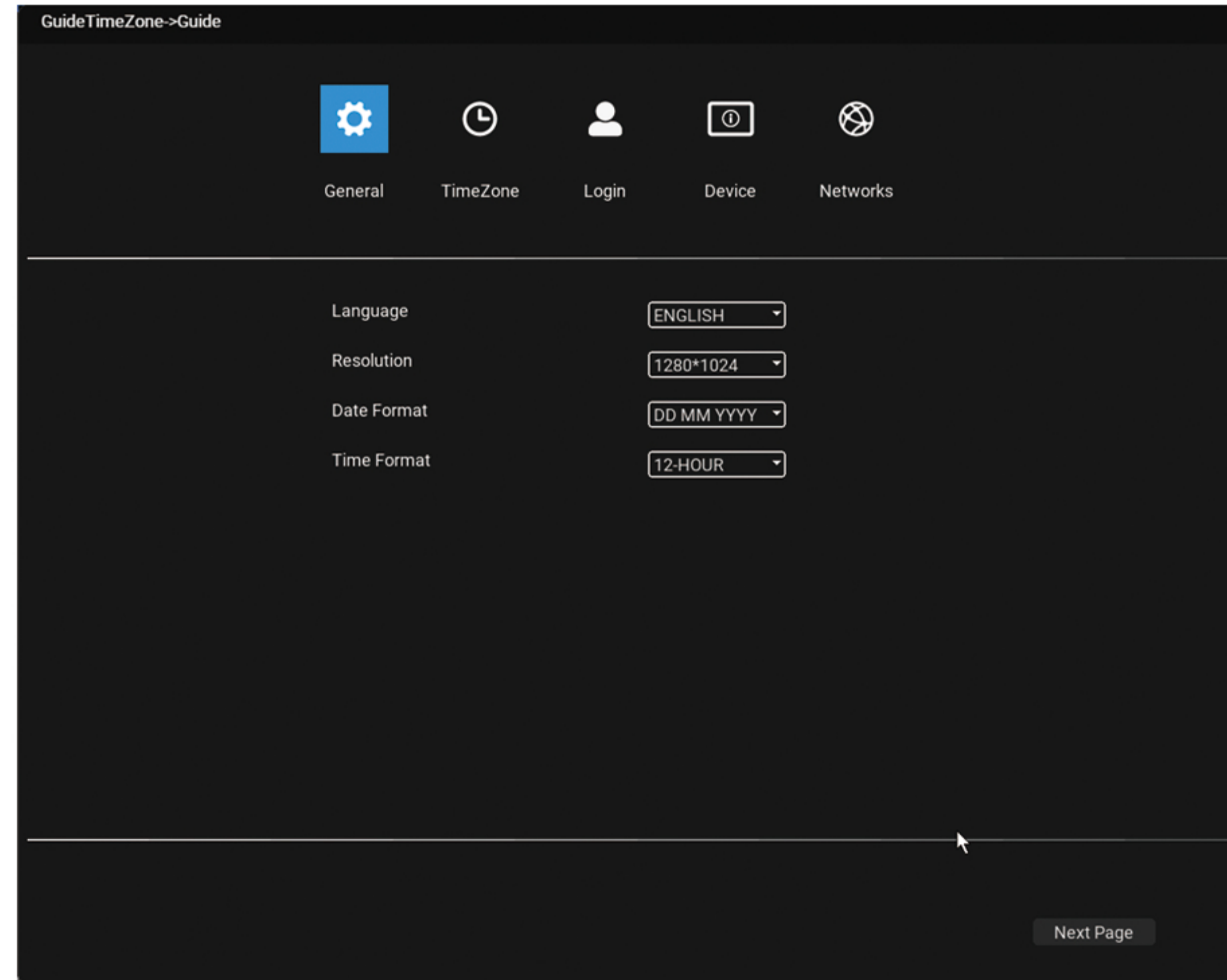

**NOTE:** The password should be at least 6 characters.

-Network Settings

Before set up the access control please make sure the device is connected to network. For Network Settings page, please go through Main Menu>Network>Network Settings:

-Choose the “DHCP Enable” (Default), or enter your personal IP address.

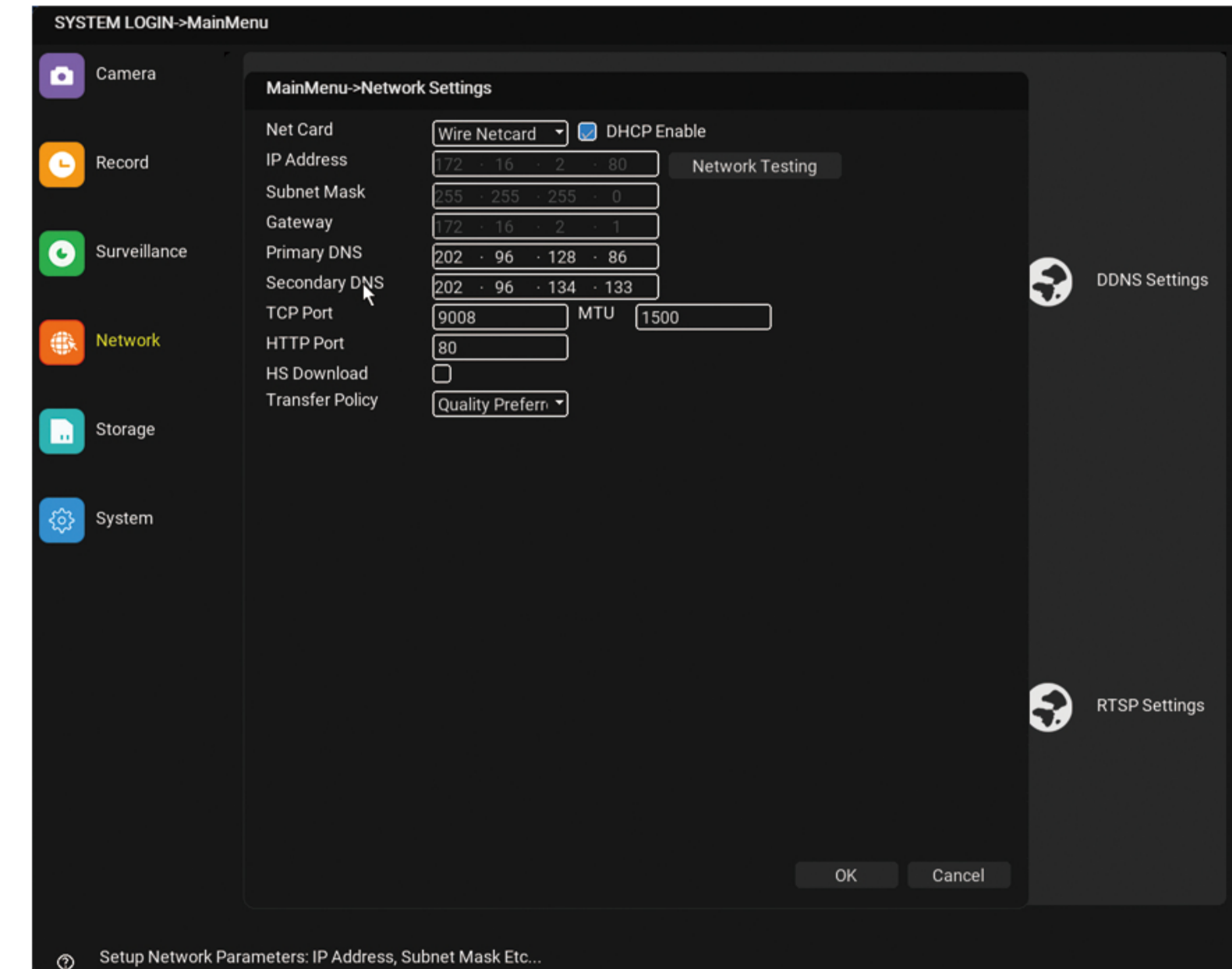

**NOTE:** If you encounter any troubles in product information, product installation and use, please email us at [support@q-see.com](mailto:support@q-see.com) or refer us to our website [www.q-see.com](http://www.q-see.com)

## Access NVR Via PC or Smartphone

Download and launch the Qsee App or Client software and follow the instructions to access the NVR

### •On PC

1. Copy the device IP Address and open it in your browser and follow the instructions to access remotely.
2. Download path: Go to [www.q-see.com](http://www.q-see.com) > Support > APP&Client download.

### •On Smartphone

Scan to download the Qsee App.



## Device Connection

- A. Register and login your account
- B. Click "+"
- C. Select "☰" or select "NVR" and click Wired.
- D. Scan the QR code on the NVR from the App and wait for the configuration.

**NOTE:-** If you are not able to find the QR code on NVR, click the Cloud ID number seen on the right top of the monitor screen and then scan the QR code to bind with App.

- E. Live Preview

Learn more: [www.q-see.com/pages/download](http://www.q-see.com/pages/download)

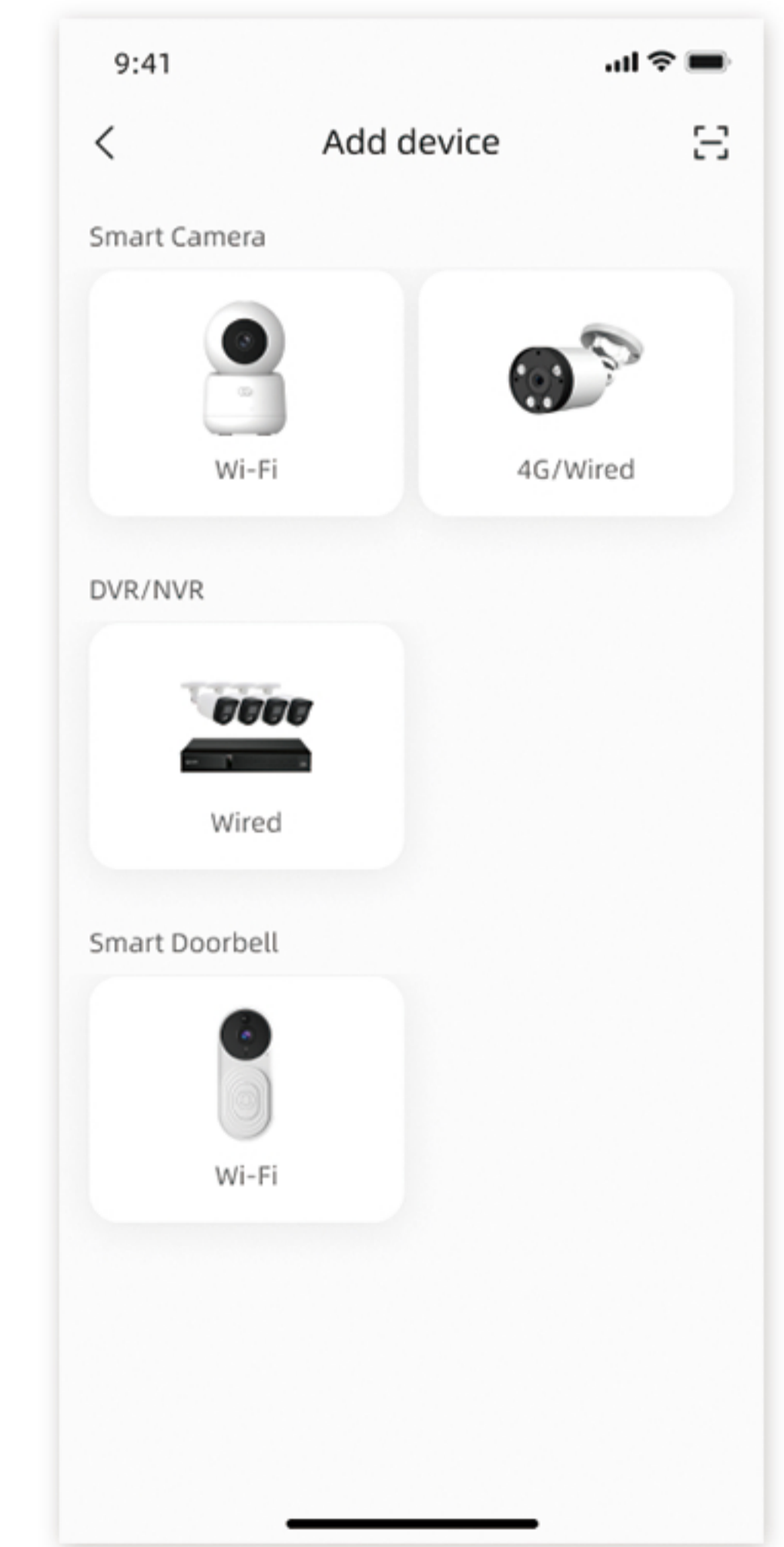
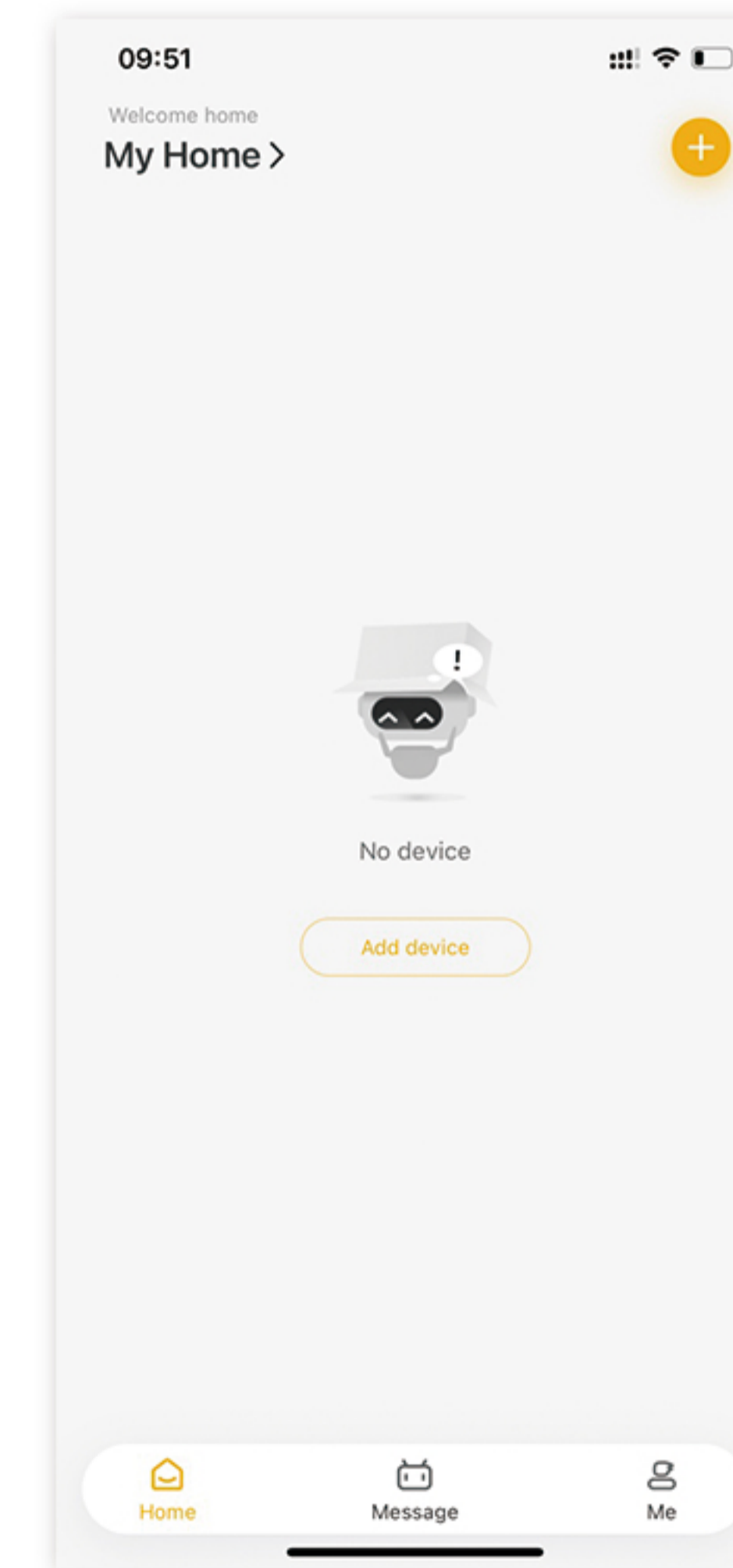
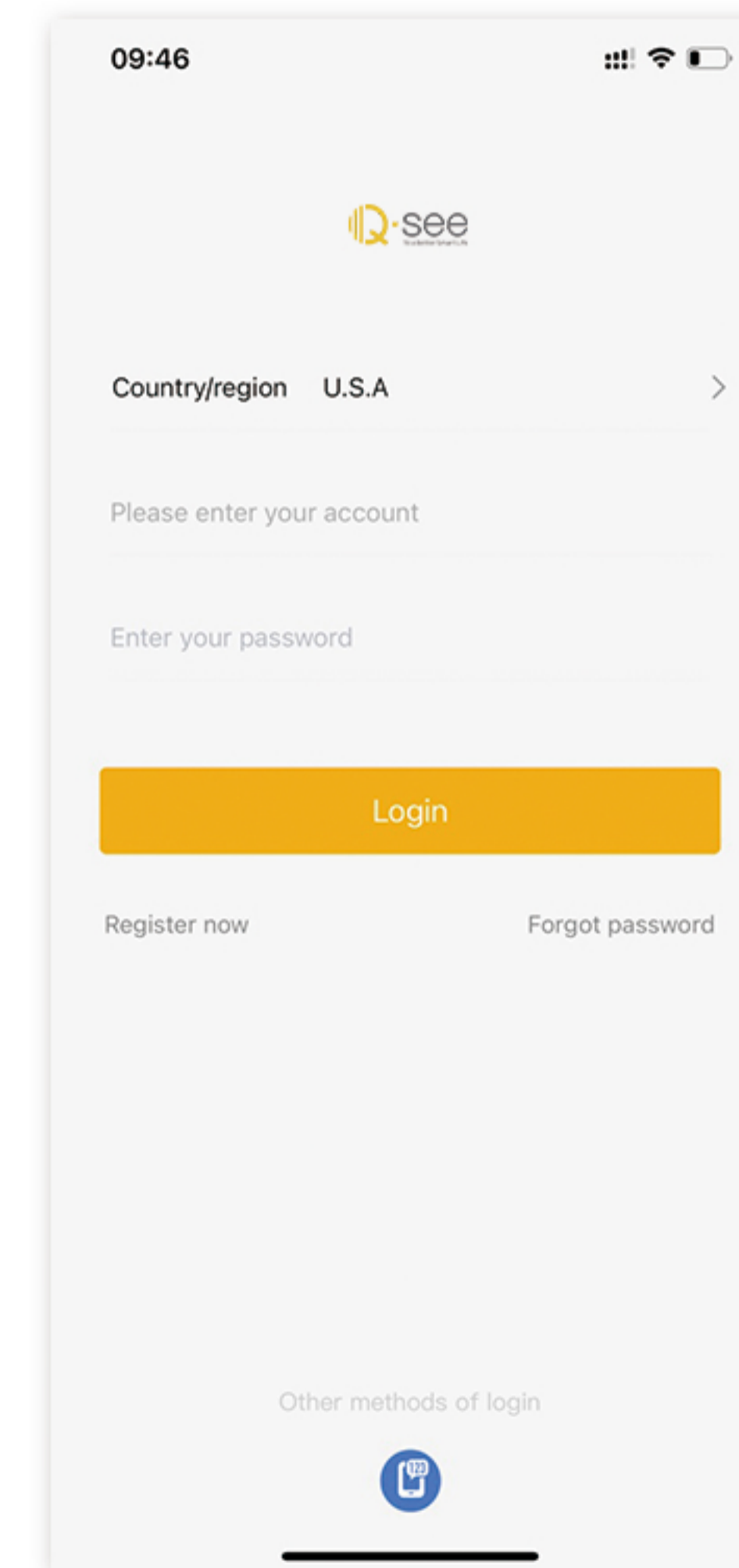

## Specification

### NVR

|                        |   |
|------------------------|---|
| Video Compression:     | H.264/H.265   |
| Video Output:          | HDMI/VGA  |
| Decoding Resolution:   | 8MP/5MP/4MP/3MP/1080p/720p                          |
| Storage Type:          | 3.5" SATA Port(max to 10TB)                         |
| Recording Mode:        | Regular/Manual/Event                                |
| Operating temperature: | -10°C ~ 55°C (14 °F ~ 131 °F)                       |
| Dimensions:            | 255 x 225 x 42mm (8CH)<br>327 x 242.7 x 54mm (16CH) |
| Weight:                | 2.0kg (8CH) / 2.5kg (16CH)                          |
| SATA HDD Port:         | 1 (8CH) / 2 (16CH)                                  |

## FAQ's

### Q: No video output on the monitor/TV

If there's no video output on the monitor from Qsee NVR, please try the following solutions:

- TV/Monitor resolution should be match with NVR, at least 1080p or above.
- Make sure your NVR is powered on.
- Double check the HDMI/VGA Connection, or swap another cable or monitor to test.

### Q: Failed to access the NVR locally

If you failed to access the NVR locally via mobile phone or PC, please try the following solutions:

- Make sure to connect the NVR (LAN port) to the router with a network cable.
- Swap another Ethernet cable or plug the NVR to other ports on the router.
- Go to Mainmenu>System>Restore>click Select all and ok button and restart by manual.

### Q: Failed to access the NVR remotely

If you failed to access the NVR remotely via mobile phone or PC, Please try the following:

- Make sure you can locally access this NVR.
- Go to the path : Main Menu>Network>Network Settings>DHCP Enable and make sure that DHCP Enable is checked.
- Please connect your phone or PC under the same network (LAN) of your NVR and see if you can visit any website to verify whether there is internet access available.
- Please reboot your NVR and router and try again.

## Notification of Compliance

### FCC Statement

This device complies with Part 15 of FCC rules. Operation is subject to the condition that this device may not cause harmful interference.

**NOTE:**– This equipment has been tested and found to comply with the limits for a class B digital device, pursuant to part 15 of the FCC rules. These limits are designed to provide reasonable protection against harmful interference in a residential installation.

### CE Declaration

Qsee declares that this device in compliance with essential requirements and other relevant provisions of EMC directive 2014/30/EU.

### RoHS Compliance declaration

Qsee products delivered to our customers confirm to the RoHS requirements, in which six banned substances are not detected or are under the limitation. The Restriction of Hazardous Substances Directive (EU) 2015/863 and (EU)2017/2102 amending Annex II to Directive 2011/65/EU. This declaration is based on Qsee's understanding of the RoHS directive and knowledge of the materials that go into products.

### Warranty

This product comes with a 2-year warranty, under certain conditions. Learn more :[www.q-see.com/policies/refund-policy](http://www.q-see.com/policies/refund-policy)

**NOTE:**– If you are not satisfied with the new Qsee product purchase, we suggest you to reset the camera and return it under specific conditions.

### Terms and Privacy

Use of the product is subject to your agreement to the terms of service and privacy policy at [www.q-see.com](http://www.q-see.com). Keep out of reach of children.

### End User License Agreement

By using the product software that is embedded in the Qsee product, you agree to the terms of this end user license agreement between you and Qsee. Learn more: [www.q-see.com/policies/terms-of-service](http://www.q-see.com/policies/terms-of-service)

### Technical Support

If you need any technical help, please visit our official support site and contact our support team before returning the products.

Email: [support@q-see.com](mailto:support@q-see.com)

Web: [www.q-see.com](http://www.q-see.com)