

Aerial Oblique Camera SHARE 202S Pro V2

User Manual v2.0

2021.03

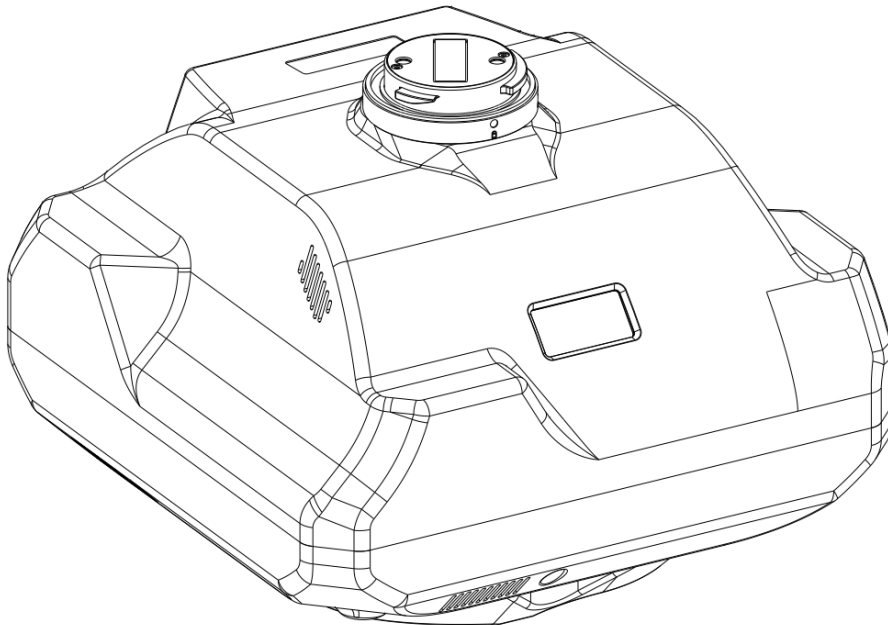

深圳赛尔智控科技有限公司
SHENZHEN SHARE UAV TECHNOLOGY CO., LTD

Disclaimer and Warning

Please read this entire document carefully to ensure proper configuration before use. The copyright of this document and all other collateral documents belong to SHENZHEN SHARE UAV TECHNOLOGY CO., LTD (abbreviated as "SHARE UAV"). SHARE UAV has the final interpretation right of this document and all other collateral documents.

SHARE UAV has right to update, modify or terminate the content of this document without prior notice. For update information, visit website www.shareuavtec.com and click on the product page for this product.

Do Not allow people under the age of 18 to use the SHARE 202S Pro V2.

Do Not modify or disassemble the SHARE 202S Pro. SHARE UAV accepts no liability for damage, injury or any legal responsibility incurred directly or indirectly from the use of this product. The user shall observe safe and lawful practices including, but not limited to, those set forth in this manual.

By using SHARE UAV products, you hereby signify that you have read this disclaimer and warning carefully and that you understand and agree to abide by the terms and condition herein. You agree that you are solely responsible for your own conduct while using this product, and for any consequences thereof. You agree to use this product only for purposes that are proper and in accordance with all applicable laws, rules, and regulations.

Contents

1. Product Overview.....	1
1.1 SHARE 202S Pro V2 Introduction.....	1
1.2 Features.....	1
1.3 In the Box.....	2
1.4 Parameters.....	2
2. Installation.....	2
2.1 Camera Introduction.....	2
2.2 Camera Installation.....	3
3. Camera Operation.....	6
3.1 Power On.....	6
3.2 Take Photo.....	8
3.3 Camera Setting.....	9
3.4 Data Copy.....	11
3.5 Repair.....	11
4. Camera Maintenance.....	12
5. After Sales.....	13
5.1 Delivery.....	13
5.2 After-sales Services.....	13

1. Product Overview

Aerial oblique camera is equipped with five high-pixel lenses, which can break through the limitations of single orthorimages on traditional mapping camera. By mounting multiple camera sensors on the same flying platform, it will acquire real images with spatial information from multiple different angles, vertical and oblique. To present more details of the texture feature. 3D data of oblique camera can realistically reflect the appearance, position, height and other attributes of ground features. Enhance the high immersion and to make up for the shortcomings of low artificial simulation of traditional modeling. It can bring revolutionary efficiency improvements to the mapping filed by using UAV and automatic modeling systems.

1.1 SHARE 202S Pro V2 Introduction

Model No.:	SHARE 202S Pro V2	Camera Type:	Oblique Camera
Total Pixels:	210 MP	Focal Length:	40 mm & 56 mm
Sensor Size:	35.9 x 24 mm	Interval:	$\geq 1.3s$
Camera Size:	160 x 160 x 125 mm	N.W.:	$\approx 1200g$
Storage:	1280 GB	Manufacturer:	SHARE UAV

The aerial oblique camera, SHARE 202S Pro V2 features five professional mapping lens with a total pixel of 210 million. It can realize high accuracy surveying and mapping with no GCP used. With high compatibility, SHARE 202S Pro V2 is able to mounted on VTOL, multi rotor and DJI M300 RTK. By using CNC designed, SHARE 202S Pro V2 is light-weight but tough structure. Smaller drag coefficient is more conducive to aerial survey flight. At the same time, SHARE 202S Pro V2 also has lots of advantages such as self-checking, one-key reset, intelligent temperature control and real-time data transmission.

1.2 Features

- * Mounting via DJI SkyPort, highly compatible with DJI M300 RTK drones
- * For other drones, mounting via J30J-15 Port
- * Compatible with DJI Terra, support one-key imported into software
- * Achieve high-precision without setting ground control points
- * Compatible with third-party software for 3D modeling, such as Context Capture
- * Camera firmware is automatically upgraded online
- * Copy data speed is up to 300MB/s through Share Data Manager
- * Real-time image transmission of downward vision
- * Real-time data on DJI Pilot (PSDK supported)
- * Professional mapping lens, high mapping working rate

1.3 In the Box

Items	Oblique Camera	Storage Box	Gimbal Cover	Data Storage Module	Data Reading Module	Data Cable	Camera Cable	Cleaning Cloth	User Manual
QTY	1pc	1pc	1pc	1pc	1pc	1pc	1pc	2pcs	1pc

1.4 Parameters

Aerial Oblique Camera(SHARE 202S Pro V2) Parameters		
Camera parameters	QTY of Lens	5 pcs
	Power on/off	Auto on/off
	Power supply	SkyPort integrated / DC 12V ~ 50V
	Photo reading	TYPE-C data cable
	Effective pixels	42.4 million (total 210 million pixels)
	Sensor size	Full frame (35.9 x 24 mm)
	Pixel size	4.5um
	Image resolution	7952 x 5304
	Oblique degree	45 degree
	Storage	1280 GB
	Exposure mode	Autopilot trigger
	Exposure time	≥1.3s
	Focal lens	45 mm x 1pc (Nadir) 56 mm x 4pcs (Oblique)
Working environment	Working temperature	0°C~50°C
	Humidity	95%
Dimensions	Size	160 x160 x 125 mm
	Weight	≈1200 g

2. Installation

2.1 Camera Introduction

The front of the oblique camera SHARE 202S Pro V2 is equipped with an OLED screen. When installing the camera, please make sure the direction of the camera and the drone is the same.

There is a SkyPort on the top of SHARE 202S Pro, it integrates all functions including the power supplying, data link, RTK signal, video transmission and mounting. It's seamless docking with DJI M300 RTK.

There is a J30J-15 port on the backside of SHARE 202S Pro V2, it also integrates functions including power supplying, communication and controlling. Through this port, it's able to be used on the other drones except for DJI drones.

2.2 Camera Installation

Mounting methods of aerial oblique camera SHARE 202S Pro:

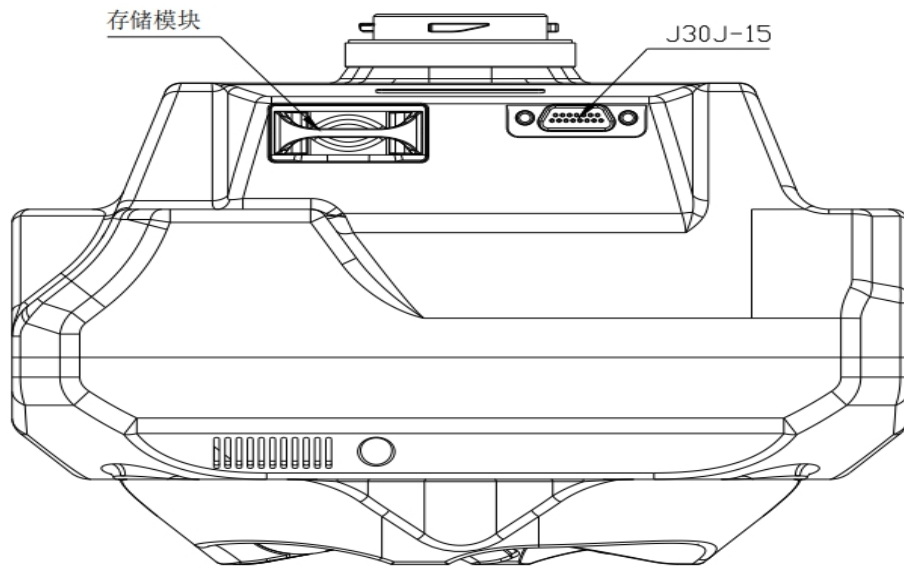

2.2.1 SkyPort Connection

Installation step:



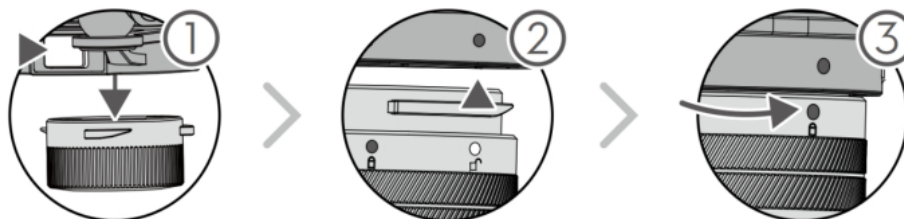

- 1) Press the button of the gimbal port, remove the gimbal cover of it.
- 2) Remove the lens cover.
- 3) Align the white dots of the two port of the camera with the red dots on the UAV, and embed them in the installation position.
- 4) Rotate the camera mount to the locked position, align the red dots to fix the white dots, and the camera installation is complete.

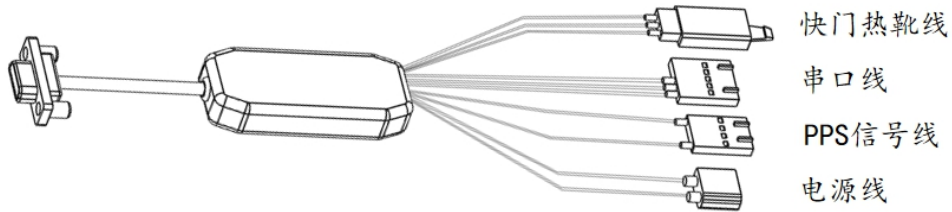

2.2.2 J30J-15 Port Connection

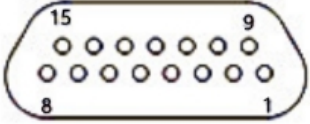

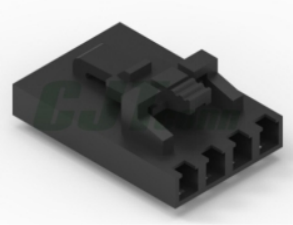
This camera cable is included in the box.

Items	Pictures	Functions
Plug A	 <p>J30J-15 芯</p>	Connect to Camera
Plug B (XT30)		Power Line (12V ~ 50V)
Plug C (A2547H-4P)		PPS Signal Cable PIN1: PPS PIN4: GND
Plug D (A2510HM-3P-R)		Shutter and Hot Shoe Cable: PIN1: Shutter PIN2: Hot shoe signal + PIN3: Hot shoe signal -

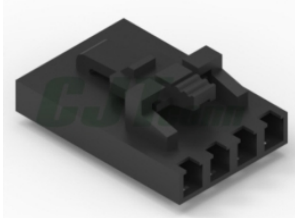
<p>Plug E (A2547H-5P)</p>		<p>TTL Cable: PIN1: NC PIN2: NC PIN3: GND PIN4: TX/RS232 TX PIN5: RX/RS232 RX</p>
-------------------------------	---	--

The end of the J30J-15 signal cable is plugged into the J30J-15 connector of the oblique camera. The power end is XT30 male, which is used to supply power to the camera; the three-pin signal plug (male) is the camera shutter hot shoe wire.

The power supply for oblique camera use the unified external power supply design. The device is compatible with 12V~50V DC power supply. When the camera is working, the instantaneous power supply needs to reach 65W to ensure the normal operation of the device; when the camera is reading data, it use the Type-C cable to connect camera with computer, doesn't need external power to camera.

2.2.3 Camera Mounted on Other Drones

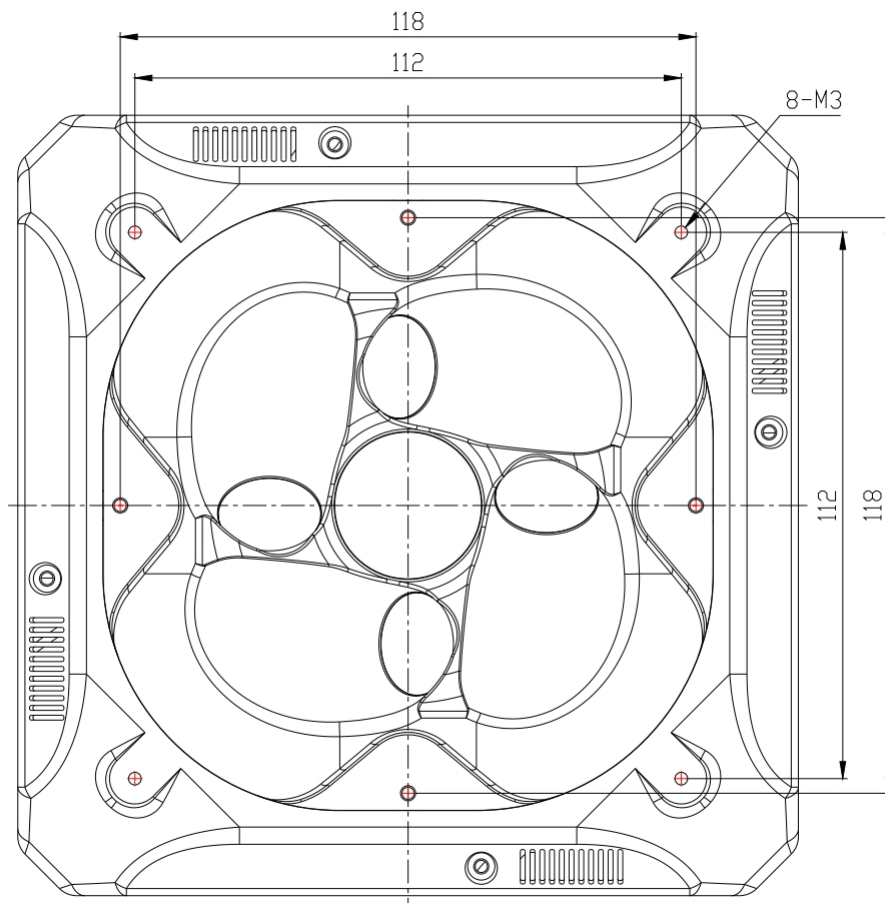

1) The bottom of the camera is square with two sets (8pc) of M3 threaded holes. The two sets of threaded holes are in "x" and "+"-shaped steps, respectively located on the square

corners with sides of 112mm and 118mm. Threaded hole depth 6mm;

2) The 4 threaded holes can be directly installed and fixed with rubber damping balls, and the installation structure can be designed according to different structures of the flying platform. The installation method is flexible and diversified.

3. Camera Operation

3.1 Power On

3.1.1 Using SkyPort

The oblique camera use drone to supply power, power on/off in sync with the drone. Take M300 RTK as an example. Step of power on:

- 1) Mount the SHARE 202S Pro on the DJI drone, and please make sure the installation is firm.
- 2) Turn on the power of the drone, the camera will start to self-checking. It will take about 40s to power on. When it's done, the camera beeps.
- 3) After the camera is turned on normally, the OLED will display as follows:

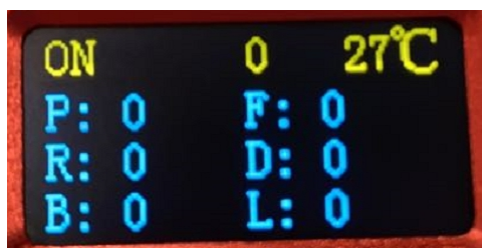

OLED Display	Meaning	Remark
ON	The camera is power on	When power off, it will show OFF
0	RTK status	RTK has 4 display statues 0-- no solution, 16-- single point solution 34-- floating point solution 50-- fixed solution
27°C	Camera temperature	Current camera temperature
P	Number of instructions triggered on taking photo	The times needed to be triggered
F, R, D, B, L	Number of taking photo on different lens	F - the front vision, R - the right vision D - the down vision, B - the back vision L - the left vision (It will restart and clear after the camera power off)

4) During the camera start up process, the real-time data window of the Pilot screen display interface displays the photo-unavailable state, and displays the photo-capable state after normal booting.

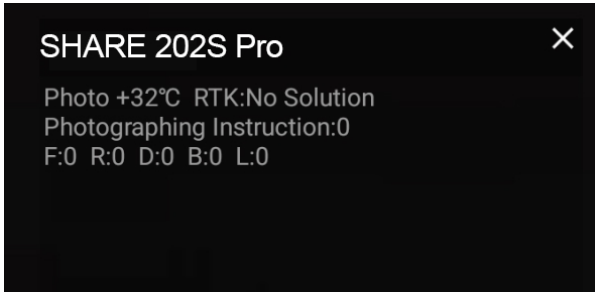

5) During the camera start up process, the time setting or camera setting interface will appear on the image transmission interface. At this time, the camera initialization will automatically switch the interface. After the camera is turned on, the image transmission image display will enter the photo interface.

3.1.2 Using J30J-15 Port

The oblique camera uses external power through XT30 plugger. It will automatically start up when power on. Step of power on:

- 1) Mount the SHARE 202S Pro V2 on the drone, and please make sure the installation is firm.
- 2) Turn on the power of the drone, the camera will start to self-checking. It will take about 40s to power on. When it’s done, the camera beeps.
- 3) After the camera is turned on normally, the OLED will display as follows:

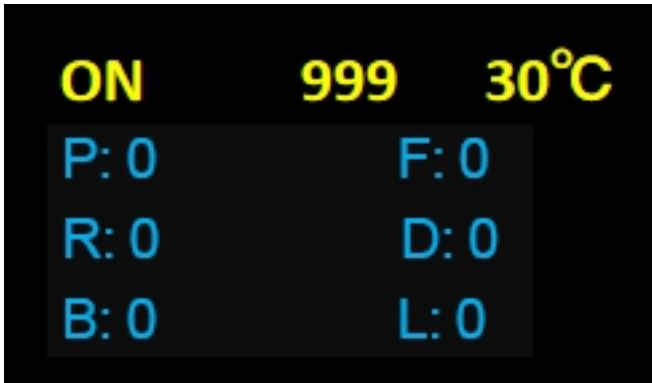

OLED Display	Meaning	Remark
ON	The camera is power on	When power off, it will show OFF
999	Initial value in PWM mode	TTL mode and TTH mode trigger photo display time value when triggered
30°C	Camera temperature	Current camera temperature
P	Number of instructions triggered on taking photo	The times needed to be triggered
F, R, D, B, L	Number of taking photo on different lens	F - the front vision, R - the right vision D - the down vision, B - the back vision L - the left vision (It will restart and clear after the camera power off)

3.2 Take Photo

3.2.1 When using DJI Pilot to control



After the oblique camera is started, the camera enters the photo-capable state. The bottom left corner of the upper picture shows the real-time image of the downward-looking camera. The indoor light is insufficient and the image is black. At this point, the user can control the camera to take a single photo by single-clicking the camera button on the right-hand side of the remote control. The real-time data window shows the current working state of the camera, and the upper one shows that the camera has been triggered five times to take a picture.

3.3 Camera Setting

Using DJI Pilot to create routes and set parameters.

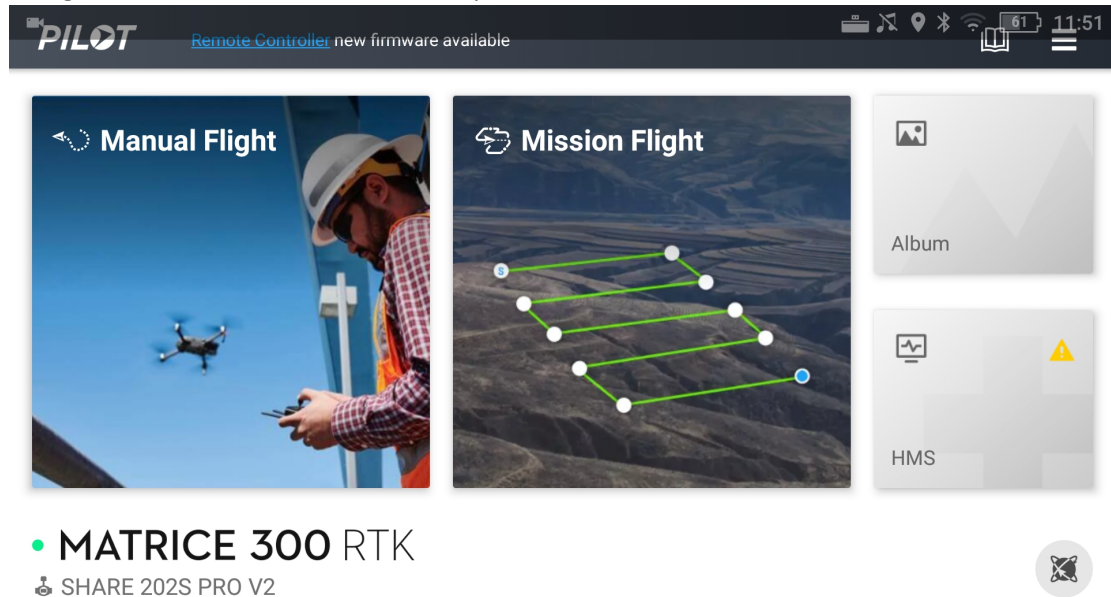

1) Setting SHARE 202S Pro oblique camera

Open DJI Pilot – Mission Flight -- Create a Route -- Mapping -- Create a mapping area – Custom Camera – Add Camera – Camera Setting -- Overlap setting

2) Parameters of SHARE 102S PRO

SHARE 202S PRO	Photo resolution (W)	Sensor size (W)	Focus
	7952px	35.9mm	40mm
	Photo resolution (H)	Sensor size (H)	Minimum interval
	5304px	24mm	1.3s

Save the camera setting.

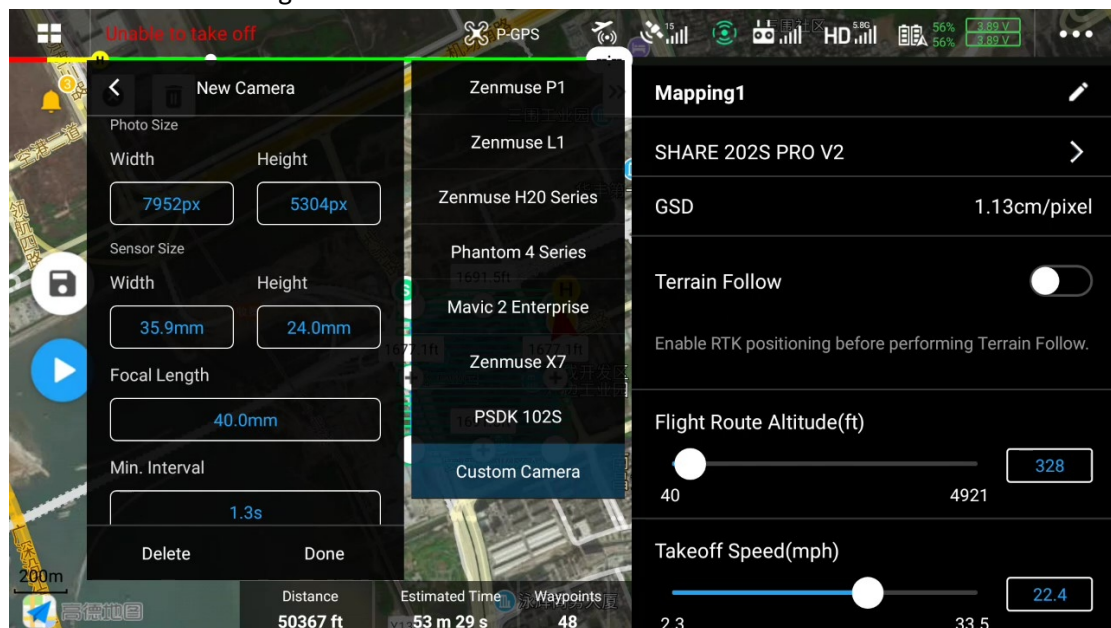

3) Payload setting

Enter the payload setting menu, which has those functions:

Items	Functions
Real-time data ON/OFF	Control the display and hide of the real-time data window
Shutter	Change the shutter speed (500/640/800/1000/1250)
ENTER	Enter button, using when the camera reports an error
ON/FF	Control camera on/off (default setting: off)
Test	Control camera shooting (default setting: off)

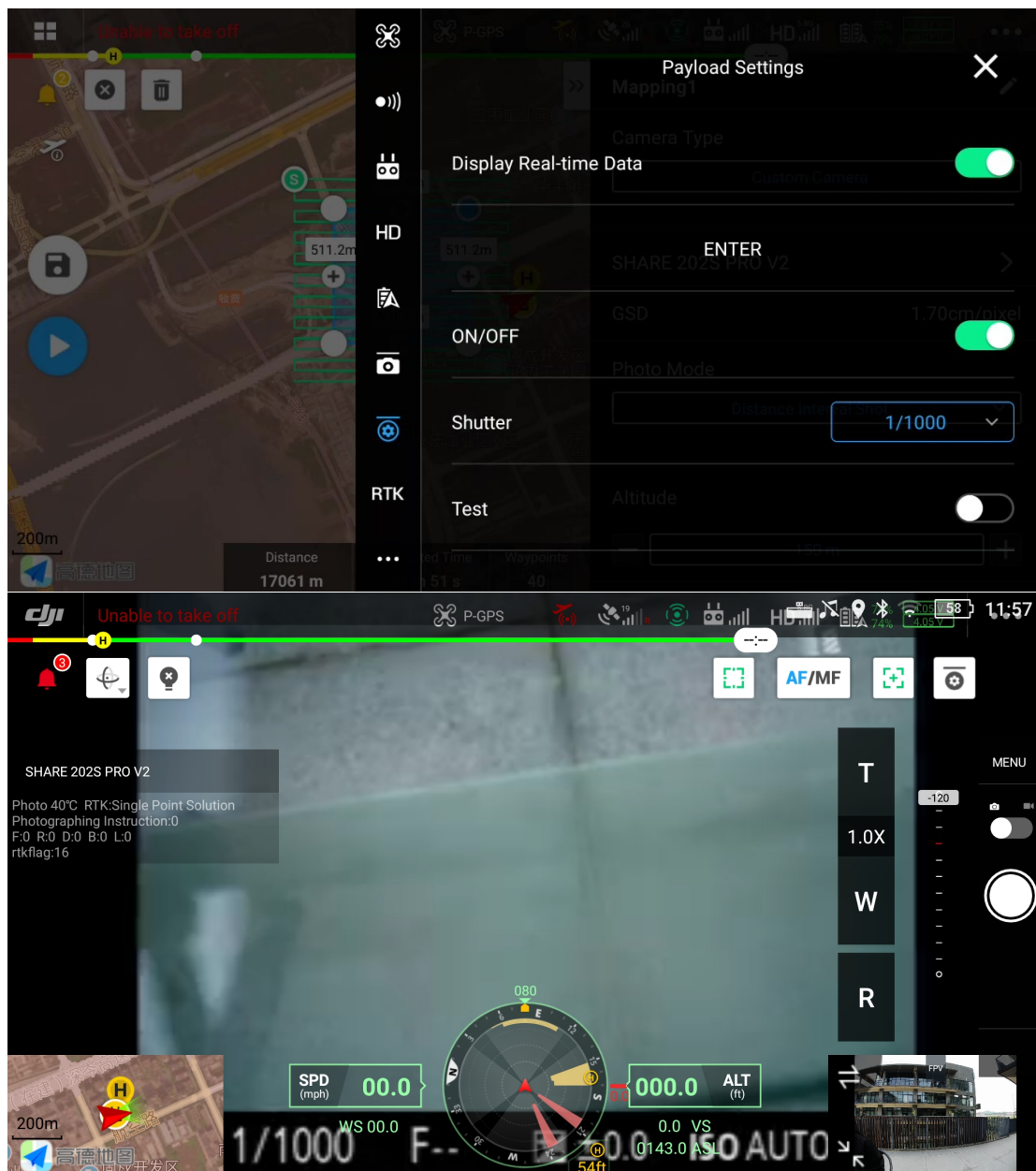

3.4 Data Copy

Different from other series of products, SHARE 202S Pro V2 camera uses a pluggable data storage module to store data. The photos and POS data collected by the camera work are stored in the data storage module. When reading data, users only need to plug the storage module into the reading data module. And connected to the computer through the data cable to view and copy the data.

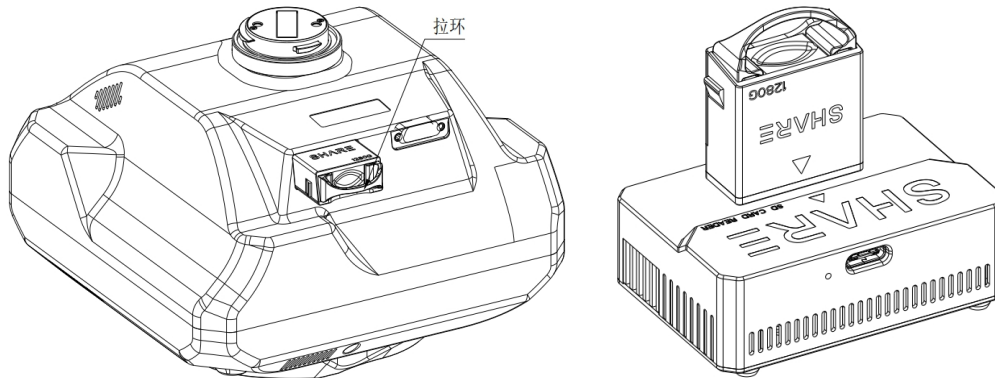

3.5 Repair

1) Common problems might happen when using oblique camera SHARE 202S Pro V2

A. Can Not find the image database file

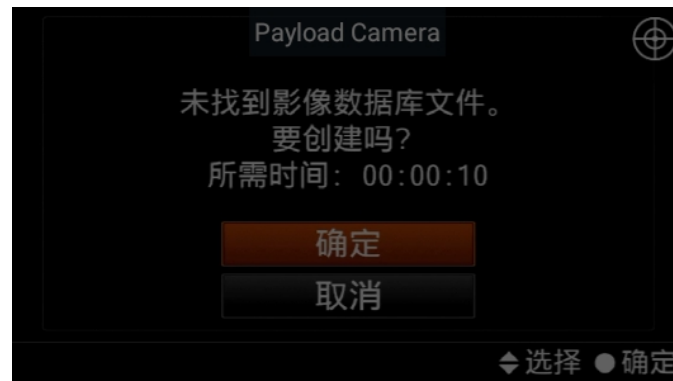

B. Image database file error

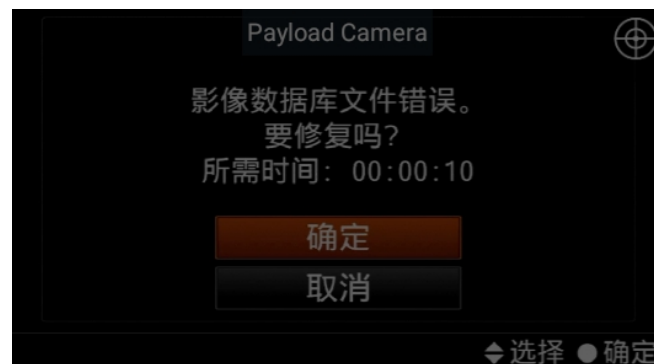

C. Can Not read the storage card



2) When the three error happen, there are two method to repair

- A. Automatic repair: user can restart the power of the device, and the camera will automatically initiate the repair.
- B. Manual repair: Click the ENTER button in the payload settings and confirm the selection according to the instructions.

4. Camera Maintenance

When using the oblique camera, please pay attention to the daily maintenance.

- 1) Avoid storing the camera in a place of extreme heat, strong vibration, close to strong magnetic field and high humidity.
- 2) Please do not use detergent containing diluent or gasoline and other organic solvents to clean UV Lens.
- 3) When storing the equipment, try to avoid long-term exposure of light to the lens.
- 4) Avoid bringing the equipment directly from cold places to warm places, and prevent moisture condensation.
- 5) The working temperature of the equipment is about $-10 \sim 45^{\circ}\text{C}$. It is not recommended to work in extremely cold and hot environment beyond the working temperature range.
- 6) Pay attention to check whether the connecting screws of the equipment are damaged or loose. It is recommended that the shutter be returned to the factory for maintenance after 200 thousand times.
- 7) Pay attention to the cleaning and drying of DJI SkyPort connecting ring, and install the protective cover in time.

5. After Sales

5.1 Delivery

(1) All equipment delivered by SHARE UAV shall be packed in accordance with the standard protective measures for packaging and transportation. Such packaging shall meet the requirements for long-distance transportation, moisture resistance, shock resistance, rust prevention, etc. required according to the specific properties of the equipment to ensure that the equipment arrived safely at the place of delivery.

(2) Packaging

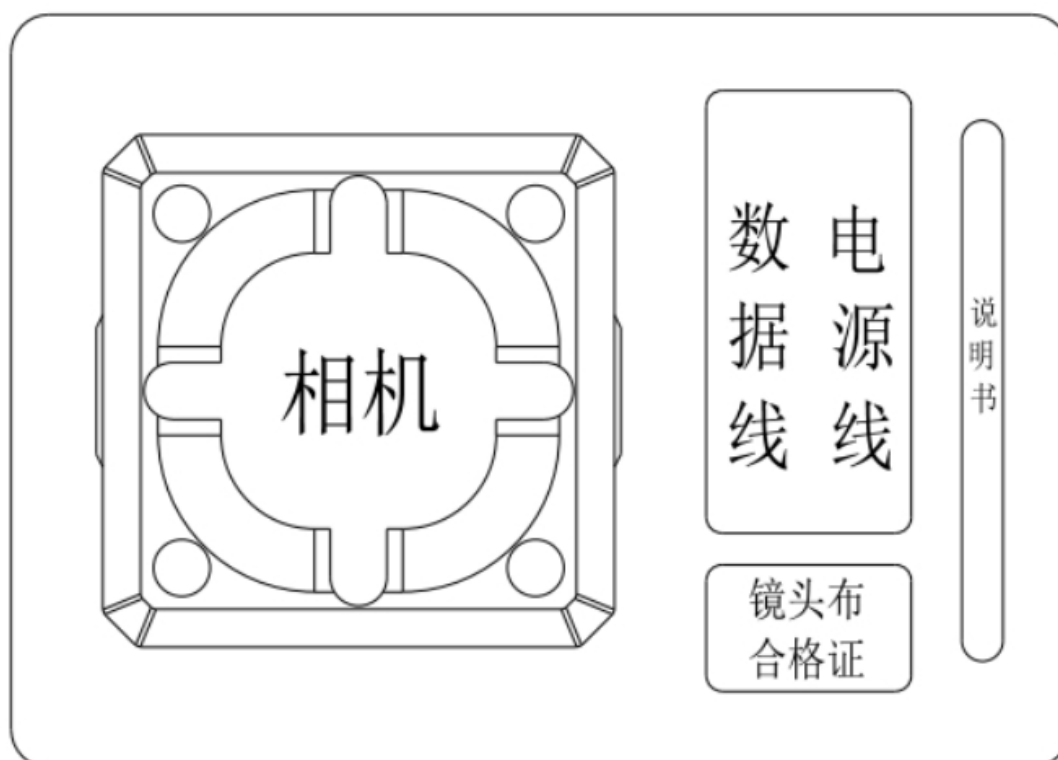

The SHARE 202S Pro V2 camera transport case uses an industrial-grade box manufacturing process. The box uses an engineering plastic moisture-proof box. The structure is strong and durable.

The position of the transport box needs to keep the cover up. It is strictly forbidden to reverse the position of the transport box. Avoid severe vibration and bump during transportation.

5.2 After-sales Services

Warranty Terms: 1year warranty since delivery.

Warranty conditions: Quality issues only. Devices with below conditions will be out of warranty even if within warranty time: damaged, out of order caused by improper usage, failure caused by misoperation or software/firmware parameter changes, or disassembled without authorization ect.

Feedback:

Share UAV Technical Support www.shareuavtec.com/en

SHARE 赛尔

If you have any questions about the product,
please contact us via the email:

info@shareuavtec.com

SHENZHEN SHARE UAV TECHNOLOGY CO., LTD

