

**Models 336, 338, 339, 750, (8)751, (8)754, 774 & 794**

# **Freezemaster Soft Serve Freezers**

**Service Manual**

**028754-S**





# Table of Contents

---

<b>Section 1: Introduction</b> .....	1
Safety .....	2
Refrigerant .....	2
Model 336 Specifications .....	3
Model 338 Specifications .....	4
Model 339 Specifications .....	5
Model 750 Specifications .....	6
Models 751/8751 Specifications .....	7
Models 754/8754 Specifications .....	8
Model 774 Specifications .....	9
Model 794 Specifications .....	10
Installation Instructions .....	11
Running Specifications .....	12
<b>Section 2: Controls</b> .....	13
Generation II Control Logic Board .....	14
Service Tips for Generation II Boards .....	19
Control Overview .....	22
Pump Operation .....	23
Refrigeration Schematic .....	24
<b>Section 3: Troubleshooting</b> .....	25
General Troubleshooting Guide .....	26
Troubleshooting Pump Style Freezers .....	29
Electrical Troubleshooting .....	30
<b>Section 4: Parts</b> .....	31
Warranty Explanation .....	32
Model 336 Exploded View .....	34
Model 336 Panel Identification .....	36
Model 338 Exploded View .....	38
Model 338 Panel Identification .....	40
Model 339 Exploded View .....	42
Model 339 Panel Identification .....	44
Model 750 Exploded View .....	46
Model 750 Panel Identification .....	48
Model 751 Exploded View .....	50
Model 751 Panel Identification .....	52

Model 754 Exploded View .....	54
Model 754 Panel Identification .....	56
Model 774 Exploded View .....	58
Model 774 Panel Identification .....	60
Rail A.-Syrup X42541 .....	62
Model 794 Exploded View .....	64
Model 794 Panel Identification .....	66
Control A. - X38324-27A (Model 336) .....	68
Control A. - X42865-27 (Model 338) .....	69
Control A. - X32963-27A (Models 339 & 754) .....	70
Control A. - X52614-27 (Model 750) .....	72
Control A. - X47194-27A (Models 751/8751) .....	73
Control A. - X42603-27A (Model 774) .....	74
Control A. - X48236-27A (Model 794) .....	75
Control A. - X48237-27 (Model 794) .....	76
Box A.-Cap & Relay - X48535-27 .....	77
Box A.-Cap & Relay - X51593-27 (Model 338) .....	78
Box A.-Cap & Relay - X52665-27 (Model 339) .....	79
Box A.-Cap & Relay - X50317-27 (Model 751) .....	80
Box A.-Cap & Relay - X50297-27 (Model 754) .....	81
Box A.-Cap & Relay - X50373-27 (Model 774) .....	82
Blower A. X53725-27 .....	83
Switch A.-Draw X43417-SER (Model 336) .....	84
Switch A.-Draw X38547 (Models 338, 339, 754, 774, 794) .....	85
Switch A.-Draw X33322-SP (Models 750, 751) .....	86
Air/Mix Pump-Soft Serve X45316-B .....	87
Models 336/338/339 Three-Spout Door A. ....	88
Models 750/751 One-Spout Beater Door A. ....	89
Models 754/774/794 Three-Spout Beater Door A. ....	90
Pump A.-Syrup 036623 (774) .....	91
Accessories .....	92
Parts List .....	93
Wiring Diagrams .....	117

**CAUTION: Information in this manual is intended to be used by Taylor Authorized Service Technicians only.**

**Note: Continuing research results in steady improvements; therefore, information in this manual is subject to change without notice.**

© January, 1999 Taylor  
All rights reserved.  
Manual No. 028754-S

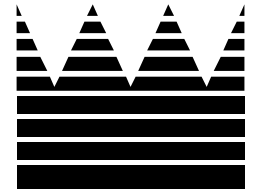

# **Section 1: Introduction**

- **Safety**
- **Refrigerant**
- **Specifications**
- **Installation Instructions**
- **Running Specifications**

# Safety

---

We at Taylor are committed to manufacturing safe operating and serviceable equipment. The many built-in safety features that are part of all Taylor equipment are aimed at protecting operators and trained service technicians alike.

This manual is intended exclusively for Taylor authorized service personnel.



**DO NOT** attempt any repairs unless the main power supply to the machine has been disconnected. Failure to follow this instruction may result in electrocution.



Stationary appliances which are not equipped with a power cord and a plug or other device to disconnect the appliance from the power source must have an all-pole disconnecting device with a contact gap of at least 3 mm installed in the external installation. Failure to follow this instruction may result in electrocution.



These machines must be placed on a level surface. Failure to comply may result in personal injury or equipment damage.



**DO NOT** install the unit in an area where a water jet could be used to clean or rinse the freezer. Failure to follow this instruction may result in serious electrical shock.

These machines are designed to operate indoors, under normal ambient temperatures of 70°-75°F (21°-24°C). The machines have successfully performed in high ambient temperatures of 104°F (40°C) at reduced capacities.

**NOISE LEVEL:** Airborne noise emission does not exceed 78 dB(A) when measured at a distance of 1.0 meter from the surface of the machine and at a height of 1.6 meters from the floor.

# Refrigerant

---

Taylor uses R404A refrigerant. This refrigerant is generally considered non-toxic and non-flammable; however, any gas under pressure is potentially hazardous.



**NEVER** fill any refrigerant cylinder completely with liquid. Filling the cylinder to approximately 80% will allow for normal expansion.



Refrigerant liquid sprayed onto the skin may cause serious damage to tissue. Keep eyes and skin protected. If refrigerant burns should occur, flush immediately with cold water. If burns are severe, apply ice packs and contact a physician immediately.



Taylor reminds technicians to be cautious of government laws regarding refrigerant recovery, recycling, and reclaiming systems. If you have any questions regarding these laws, please contact the factory Service Department.

**WARNING:** R404A refrigerant used in conjunction with polyolester oils is extremely moisture absorbent. When opening a refrigeration system, the maximum time the system is open must not exceed 15 minutes. Cap all open tubing to prevent humid air or water from being absorbed by the oil.



If the crossed out wheeled bin symbol is affixed to this product, it signifies that this product is compliant with the EU Directive as well as other similar legislation in effect after August 13, 2005. Therefore, it must be collected separately after its use is completed, and cannot be disposed as unsorted municipal waste.

The user is responsible for returning the product to the appropriate collection facility, as specified by your local code.

For additional information regarding applicable local laws, please contact the municipal facility and/or local distributor.

# Model 336 Specifications

## Freezing Cylinder

Two, 2.8 quart (2.7 liter) volume.

## Mix Hopper

Two, 8 quart (7.6 liter) capacity.

## Beater Motor

Two, 1.0 hp.

## Refrigeration Unit

One, approximately 9,500 btu/hr compressor.  
Refrigerant R404A.

One independent (SHR) compressor, approximately 400 btu/hr. Refrigerant R134a.  
(BTU's may vary based on compressor used.)

## Electrical

Electrical	One dedicated connection.	
	Maximum Fuse Size	Minimum Circuit Ampacity
208-230/60/1 Air	35	29
208-230/60/1 Water	35	26
208-230/60/3 Air	25	21
208-230/60/3 Water	25	18

This unit is manufactured in other electrical characteristics. Refer to the Distributor Data Book for availability. (For exact electrical information, always refer to the data label of the unit.)

## Air Cooled

Clearance: 3" (76 mm) around all sides. A deflector has been added to underside, preventing recirculation of warm air. This will assure proper air flow across condensers to obtain optimum performance.

## Water Cooled

Water inlet and drain connections under side of base 3/8" FPT.

## Dimensions

Width: 20-7/16" (519 mm)  
Depth: 33-3/16" (843 mm)  
Height: 60" (1524 mm)  
Floor Clearance: 7-3/4" (197 mm) mounted on standard casters.

## Approximate Weights

Net: 575 lbs. (260.8 kgs.)  
Crated: 628 lbs. (284.9 kgs.), 39.1 cu. ft. (1.10 cu. m.)

**Availability and specifications are subject to change without notice.**

This unit is designed and constructed to meet stringent safety and sanitation requirements for NSF and UL.

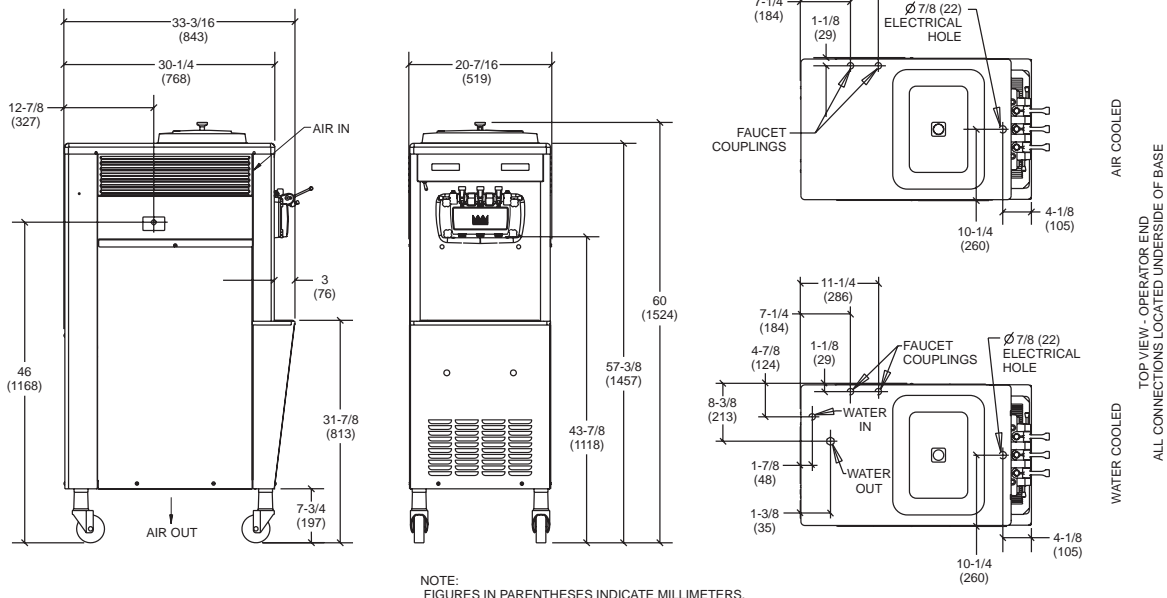

# Model 338 Specifications

## Freezing Cylinder

Two, 2.8 quart (2.7 liter) volume.

## Mix Hopper

Two, 20 quart (18.9 liter).

## Beater Motor

Two, 1.0 hp.

## Refrigeration Unit

One, approximately 9,500 btu/hr compressor. Refrigerant R404A.

One independent (SHR) compressor, approximately 400 btu/hr. Refrigerant R134a.

(BTU's may vary based on compressor used.)

## Electrical

Electrical	One dedicated connection.	
	Maximum Fuse Size	Minimum Circuit Ampacity
208-230/60/1 Air	35	28
208-230/60/1 Water	35	28
208-230/60/3 Air	25	19
208-230/60/3 Water	25	19

This unit is manufactured in other electrical characteristics. Refer to the Distributor Data Book for

availability. (For exact electrical information, always refer to the data label of the unit.)

## Air Cooled

Clearance: 6" (152 mm) on both sides. It is recommended to install a skirt to one side of the unit, and to place the back of the unit against a wall. This will assure proper air flow across condensers to obtain optimum performance.

## Water Cooled

Water inlet and drain connections under side of base 3/8" FPT.

## Dimensions

Width: 26-7/16" (672 mm)

Depth: 31-3/16" (792 mm)

Height: 38-3/4" (984 mm)

Counter Clearance: 3-1/2" (89 mm) mounted on standard legs.

## Approximate Weights

Net: 465 lbs. (219.0 kgs.)

Crated: 542 lbs. (245.9 kgs.), 29.9 cu. ft. (.84 cu. m.)

**Availability and specifications are subject to change without notice.**

This unit is designed and constructed to meet stringent safety and sanitation requirements for NSF and UL.

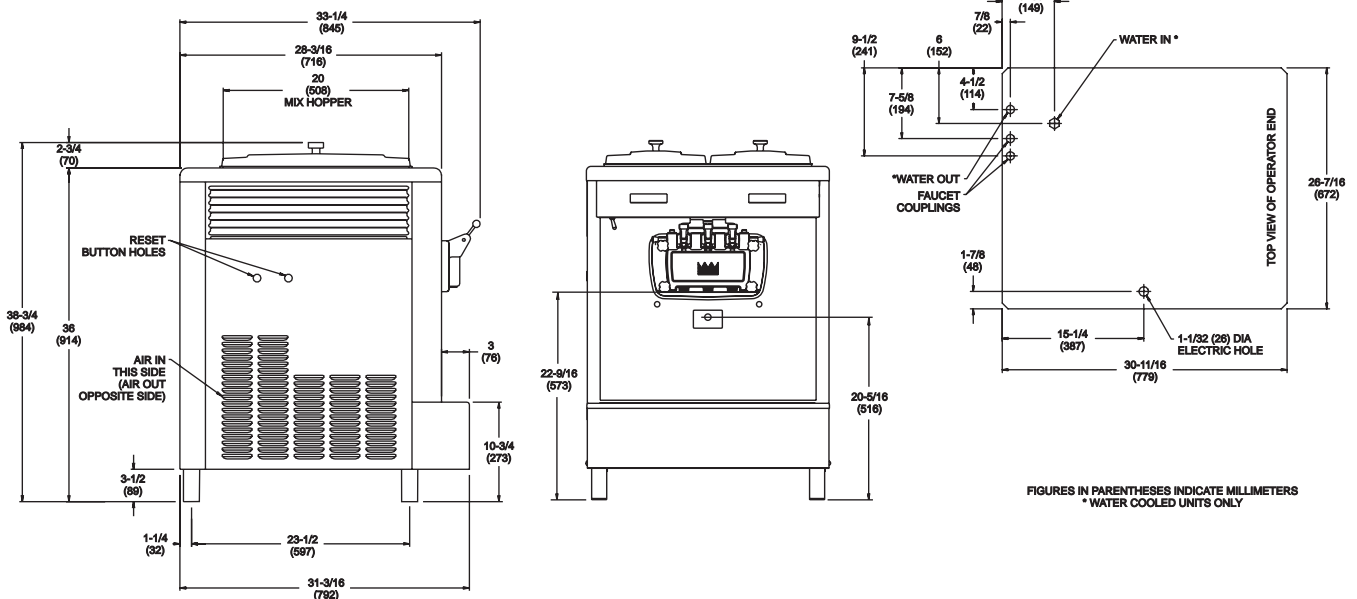



# Model 339 Specifications

## Freezing Cylinder

Two, 2.8 quart (2.7 liter) volume.

## Mix Hopper

Two, 20 quart (18.9 liter) capacity.

## Beater Motor

Two, 1.0 hp.

## Refrigeration Unit

Two, approximately 6,000 btu/hr compressors.  
Refrigerant R404A.

One independent (SHR) compressor, approximately 400 btu/hr. Refrigerant R134a.  
(BTU's may vary based on compressor used.)

## Electrical

Electrical	Two dedicated connections.			
	Maximum Fuse Size		Minimum Circuit Ampacity	
	Left	Right	Left	Right
208-230/60/1 Air	25	20	19	14
208-230/60/1 Water	20	20	16	14
208-230/60/3 Air	20	15	16	12
208-230/60/3 Water	20	15	14	12

This unit is manufactured in other electrical characteristics. Refer to the Distributor Data Book for

availability. (For exact electrical information, always refer to the data label of the unit.)

## Air Cooled

Clearance: 3" (76 mm) around all sides. A deflector has been added to underside preventing recirculation of warm air. This will assure proper air flow across condensers to obtain optimum performance.

## Water Cooled

Water inlet and drain connections under side of base 1/2" FPT.

## Dimensions

Width: 26-7/16" (672 mm)

Depth: 33" (838 mm)

Height: 59-7/8" (1521 mm)

Floor Clearance: 7-1/2" (191 mm) mounted on standard casters.

## Approximate Weights

Net: 608 lbs. (275.8 kgs.)

Crated: 698 lbs. (316.6 kgs.), 48.1 cu. ft. (1.3 cu. m.)

**Availability and specifications are subject to change without notice.**

This unit is designed and constructed to meet stringent safety and sanitation requirements for NSF and UL.

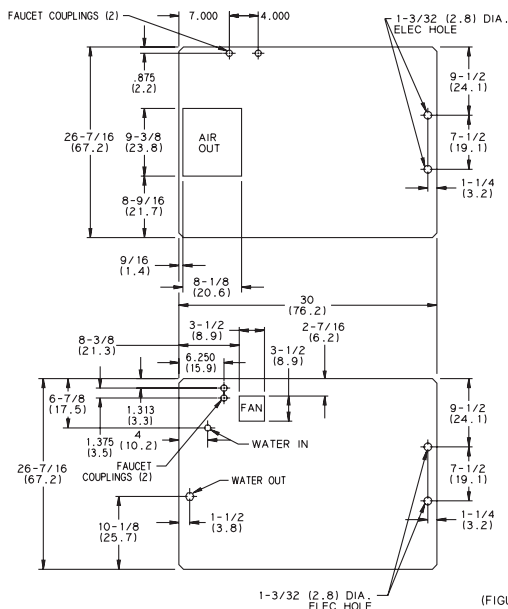

(FIGURES IN PARENTHESES INDICATE CENTIMETERS)

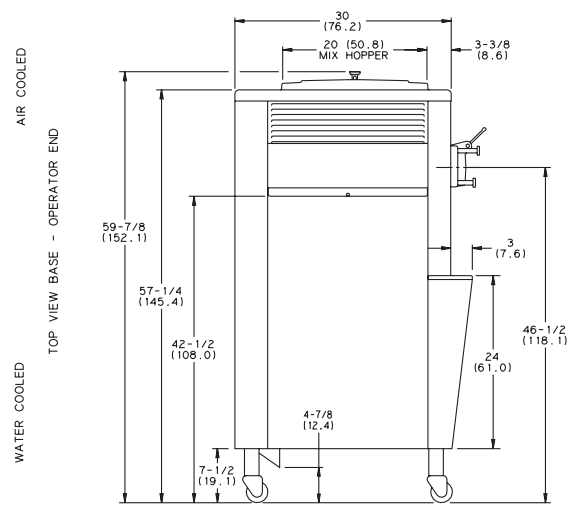

# Model 750 Specifications

## Freezing Cylinder

One, 3.4 quart (3.2 liter) volume.

## Mix Hopper

One, 20 quart (18.9 liter) capacity.

## Beater Motor

One, 1.5 hp.

## Refrigeration Unit

One, approximately 4,900 btu/hr compressor. Refrigerant R404A.

One independent (SHR) compressor, approximately 400 btu/hr. Refrigerant R134a. (BTU's may vary based on compressor used.)

## Electrical

Electrical	One dedicated connection.	
	Maximum Fuse Size	Minimum Circuit Ampacity
208-230/60/1 Air	20	18
208-230/60/1 Water	20	18
208-230/60/3 Air	15	12
208-230/60/3 Water	15	12

This unit is manufactured in other electrical characteristics. Refer to the Distributor Data Book for

availability. (For exact electrical information, always refer to the data label of the unit.)

## Air Cooled

Clearance: 6" (152 mm) on both sides. It is recommended to place the back of the unit against a wall. This will assure proper air flow across condensers to obtain optimum performance.

## Water Cooled

Water inlet and drain connections 3/8" FPT.

## Dimensions

Width: 18-7/16" (468 mm)

Depth: 31-3/16" (792 mm)

Height: 37-7/8" (962 mm)

Counter Clearance: 4-1/2" (108 mm) mounted on standard legs.

## Approximate Weights

Net: 360 lbs. (163.3 kgs.)

Crated: 410 lbs. (186.0 kgs.), 29.1 cu. ft. (.81 cu. m.)

**Availability and specifications are subject to change without notice.**

This unit is designed and constructed to meet stringent safety and sanitation requirements for NSF and UL.

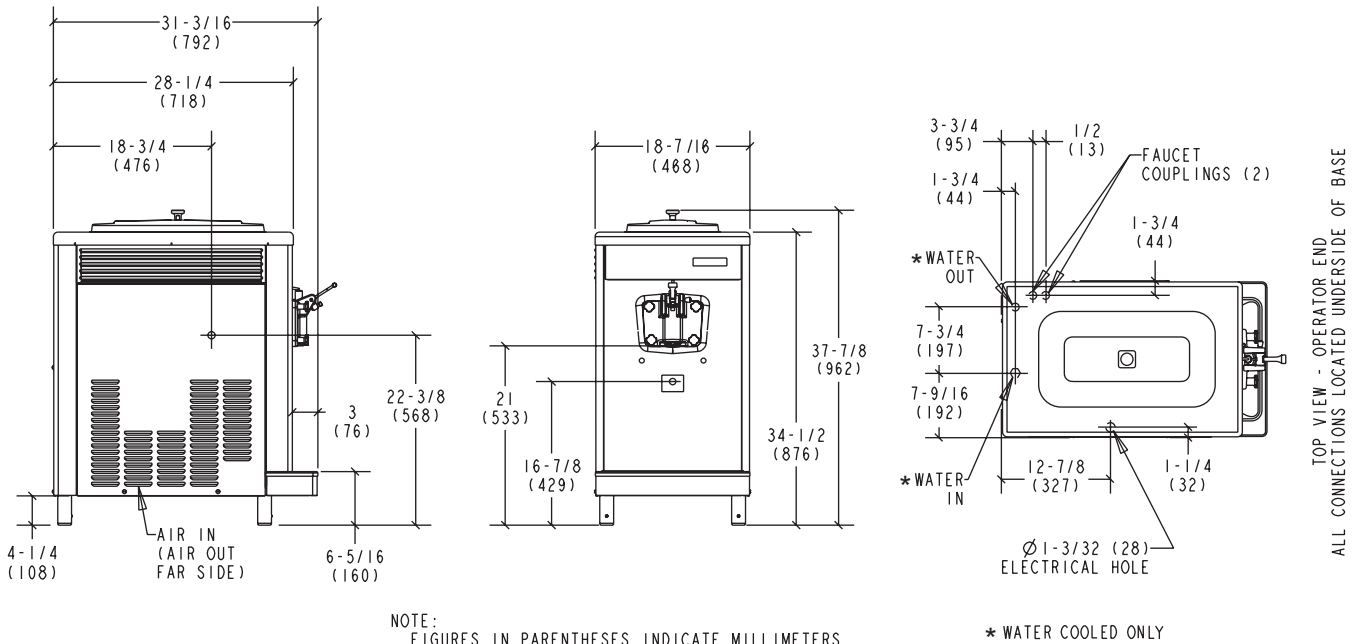

# Models 751/8751 Specifications

## Freezing Cylinder

One, 3.4 quart (3.2 liter) volume.

## Mix Hopper

One, 20 quart (18.9 liter) capacity.

## Beater Motor

One, 1.5 hp.

## Refrigeration Unit

One, approximately 9,500 btu/hr compressor. Refrigerant R404A.

One independent (SHR) compressor, approximately 400 btu/hr. Refrigerant R134a. (BTU's may vary based on compressor used.)

## Electrical

Electrical	One dedicated connection.	
Model 751	Maximum Fuse Size	Minimum Circuit Ampacity
208-230/60/1 Air	35	26
208-230/60/1 Water	30	24
208-230/60/3 Air	25	19
208-230/60/3 Water	20	17
Model 8751		
208-230/60/1 Air	35	28
208-230/60/1 Water	35	25
208-230/60/3 Air	25	21
208-230/60/3 Water	25	18

These units are manufactured in other electrical characteristics. Refer to the Distributor Data Book for availability. (For exact electrical information, always refer to the data label of the unit.)

## Air Cooled

Clearance: 3" (76 mm) around all sides. A deflector has been added to underside preventing recirculation of warm air. This will assure proper air flow across condensers to obtain optimum performance.

## Water Cooled

Water inlet and drain connections 3/8" FPT.

## Dimensions

Width: 18-7/16" (468 mm)

Depth: 31-3/16" (792 mm)

Height: 59-7/8" (1521 mm)

Floor Clearance: 7-1/2" (191 mm) mounted on standard casters.

## Approximate Weights

### Model 751:

Net: 455 lbs. (201.9 kgs.)

Crated: 476 lbs. (215.9 kgs.), 35.4 cu. ft. (.99 cu. m.)

### Model 8751:

Net: 480 lbs. (217.7 kgs.)

Crated: 501 lbs. (227.2 kgs.), 35.4 cu. ft. (.99 cu. m.)

**Availability and specifications are subject to change without notice.**

These units are designed and constructed to meet stringent safety and sanitation requirements for NSF and UL.

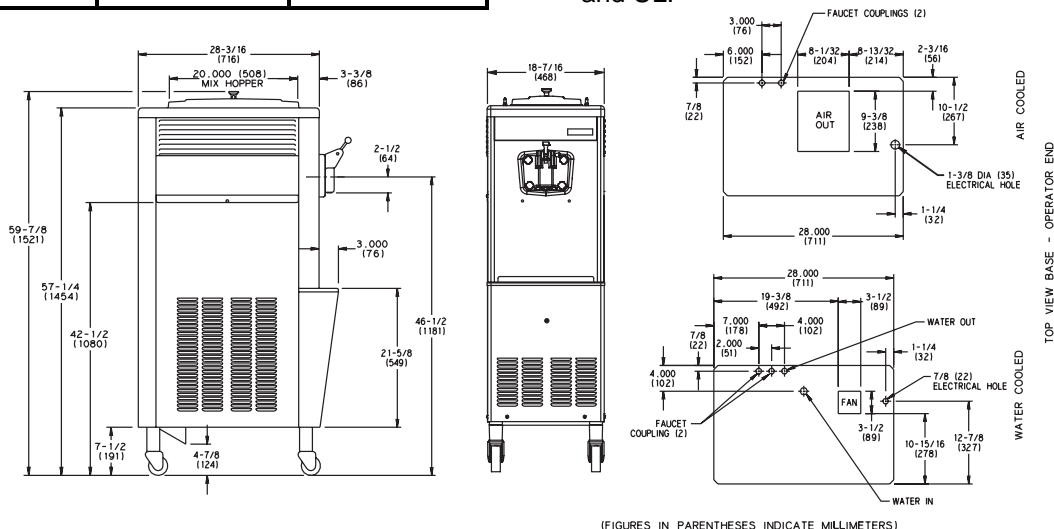

(FIGURES IN PARENTHESES INDICATE MILLIMETERS)

# Models 754/8754 Specifications

## Freezing Cylinder

Two, 3.4 quart (3.2 liter) volume.

## Mix Hopper

Two, 20 quart (18.9 liter) capacity.

## Beater Motor

Two, 1.5 hp.

## Refrigeration Unit

Two, approximately 9,500 btu/hr compressors. Refrigerant R404A.  
One independent (SHR) compressor, approximately 400 btu/hr. Refrigerant R134a.  
(BTU's may vary based on compressor used.)

## Electrical

Electrical	Two dedicated connections.			
	Maximum Fuse Size		Minimum Circuit Ampacity	
Model 754	Left	Right	Left	Right
208-230/60/1 Air	35	30	26	22
208-230/60/1 Water	30	30	24	22
208-230/60/3 Air	25	20	19	15
208-230/60/3 Water	20	20	17	15
Model 8754				
208-230/60/1 Air	35	30	28	24
208-230/60/1 Water	35	30	25	24
208-230/60/3 Air	25	20	21	17
208-230/60/3 Water	25	20	18	17

These units are manufactured in other electrical characteristics. Refer to the Distributor Data Book for availability. (For exact electrical information, always refer to the data label of the unit.)

## Air Cooled

Clearance: 3" (76 mm) around all sides. A deflector has been added to underside preventing recirculation of warm air. This will assure proper air flow across condensers to obtain optimum performance.

## Water Cooled

Water inlet and drain connections under side of base 1/2" FPT.

## Dimensions

Width: 26-7/16" (672 mm)  
Depth: 33" (838 mm)  
Height: 59-7/8" (1521 mm)  
Floor Clearance: 7-1/2" (191 mm) mounted on standard casters.

## Approximate Weights

**Model 754:**  
Net: 680 lbs. (308.4 kgs.)  
Crated: 707 lbs. (320.7 kgs.), 47.3 cu. ft. (1.34 cu. m.)

**Model 8754:**  
Net: 730 lbs. (331.1 kgs.)  
Crated: 768 lbs. (348.4 kgs.), 47.3 cu. ft. (1.34 cu. m.)

**Availability and specifications are subject to change without notice.**

These units are designed and constructed to meet stringent safety and sanitation requirements for NSF and UL.

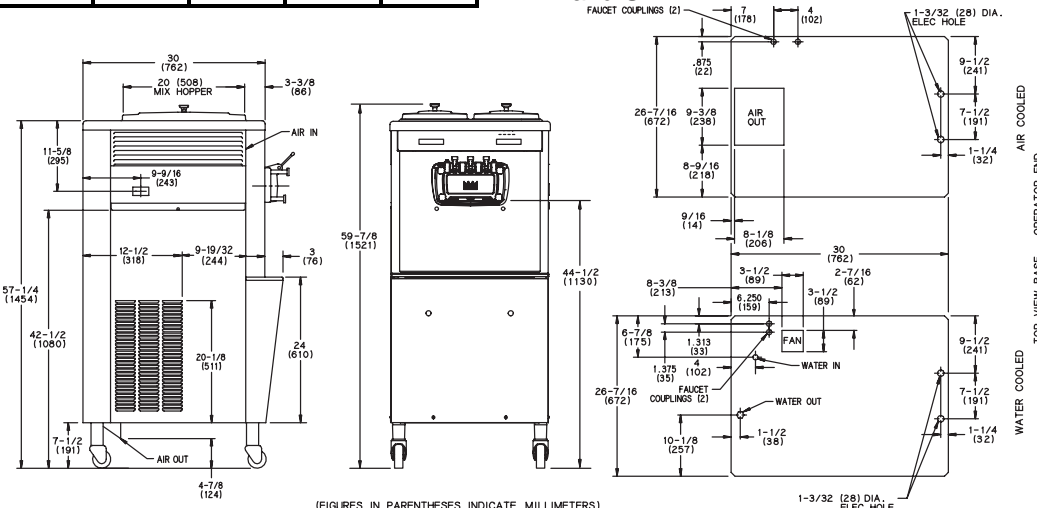

# Model 774 Specifications

## Freezing Cylinder

Two, 3.4 quart (3.2 liter) volume.

## Mix Hopper

Two, 20 quart (18.9 liter) capacity.

## Beater Motor

Two, 1.5 hp.

## Refrigeration Unit

Two, approximately 9,500 btu/hr compressors.  
Refrigerant R404A.

One independent (SHR) compressor, approximately 400 btu/hr. Refrigerant R134a.  
(BTU's may vary based on compressor used.)

## Electrical

Electrical	Two dedicated connections.			
	Maximum Fuse Size		Minimum Circuit Ampacity	
	Left	Right	Left	Right
208-230/60/1 Air	35	30	28	22
208-230/60/1 Water	35	30	25	22
208-230/60/3 Air	25	20	21	15
208-230/60/3 Water	25	20	18	15

This unit is manufactured in other electrical characteristics. Refer to the Distributor Data Book for

availability. (For exact electrical information, always refer to the data label of the unit.)

## Air Cooled

Clearance: 3" (76 mm) around all sides. A deflector has been added to underside preventing recirculation of warm air. This will assure proper air flow across condensers to obtain optimum performance.

## Water Cooled

Water inlet and drain connections under side of base 1/2" FPT.

## Dimensions

Width: 26-7/16" (672 mm)  
Depth: 36-3/16" (919 mm)  
Height: 59-7/8" (1521 mm)  
Floor Clearance: 7-1/2" (191 mm) mounted on standard casters.

## Approximate Weights

Net: 760 lbs. (344.7 kgs.)  
Crated: 865 lbs. (392.4 kgs.), 49.7 cu. ft. (1.3 cu. m.)

**Availability and specifications are subject to change without notice.**

This unit is designed and constructed to meet stringent safety and sanitation requirements for NSF and UL.

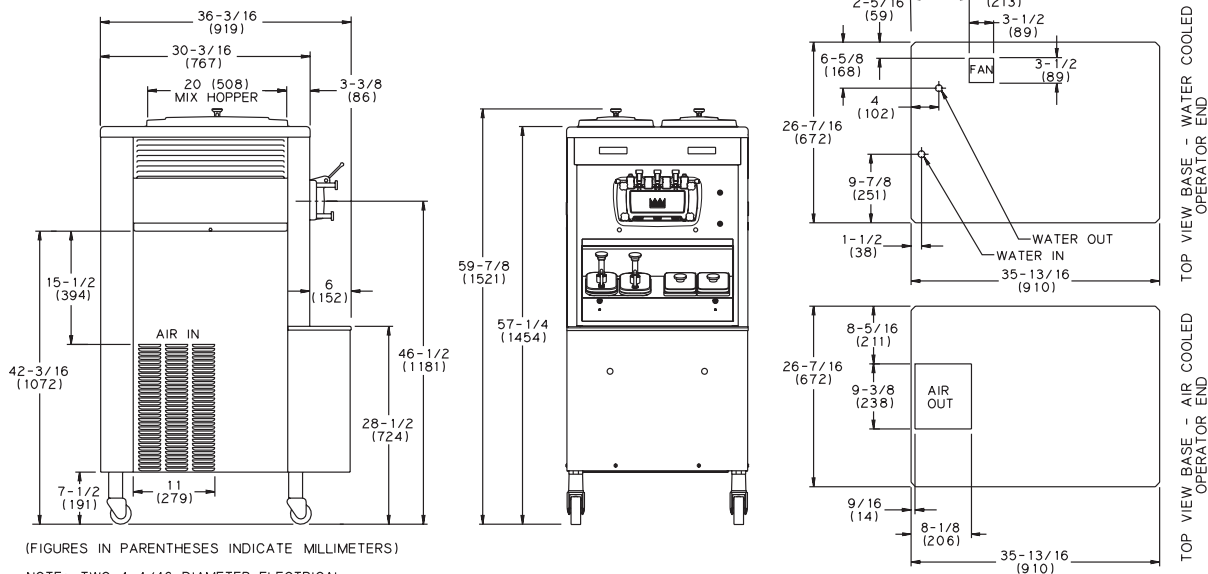

# Model 794 Specifications

## Freezing Cylinder

Two, 3.4 quart (3.2 liter) volume.

## Mix Hopper

Two, 14 quart (13.3 liter) capacity.

## Beater Motor

Two, 1.5 hp.

## Refrigeration Unit

Two, approximately 9,500 btu/hr compressors.  
Refrigerant R404A.

One independent (SHR) compressor, approximately 400 btu/hr. Refrigerant R134a.  
(BTU's may vary based on compressor used.)

## Electrical

Electrical	Two dedicated connections.			
	Maximum Fuse Size		Minimum Circuit Ampacity	
	Left	Right	Left	Right
208-230/60/1 Air	35	35	28	23
208-230/60/1 Water	35	35	25	23
208-230/60/3 Air	25	20	20	16
208-230/60/3 Water	25	20	17	16

This unit is manufactured in other electrical characteristics. Refer to the Distributor Data Book for

availability. (For exact electrical information, always refer to the data label of the unit.)

## Air Cooled

Clearance: 3" (76 mm) around all sides. A deflector has been added to underside preventing recirculation of warm air. This will assure proper air flow across condensers to obtain optimum performance.

## Water Cooled

Water inlet and drain connections under side of base 1/2" FPT.

## Dimensions

Width: 20-7/16" (519 mm)  
Depth: 33-3/16" (843 mm)  
Height: 59-1/2" (1511 mm)  
Floor Clearance: 7-1/2" (191 mm) mounted on standard casters.

## Approximate Weights

Net: 690 lbs. (312.9 kgs.)  
Crated: 747 lbs. (338.8 kgs.), 39.1 cu. ft. (1.1 cu. m.)

**Availability and specifications are subject to change without notice.**

This unit is designed and constructed to meet stringent safety and sanitation requirements for NSF and UL.

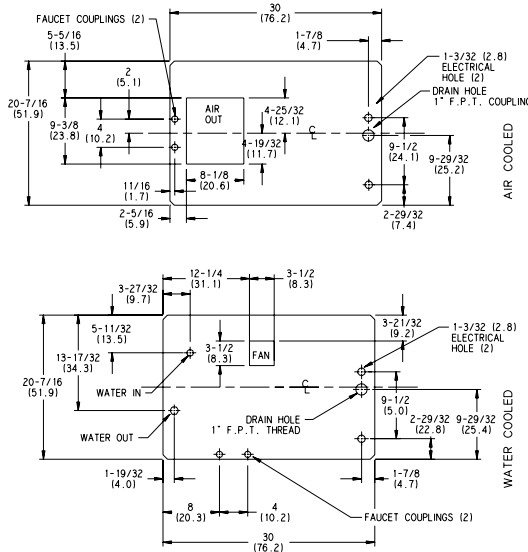

(FIGURES IN PARENTHESES INDICATE CENTIMETERS)

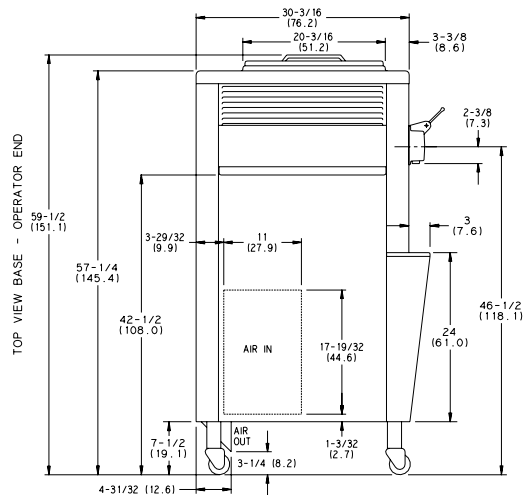

# Installation Instructions

---

## Air Cooled Units

Air cooled units require a minimum of 3" (76 mm) of clearance around all sides of the freezer (6" [152 mm] for Models 338 and 750). Failure to allow for adequate clearance can reduce the refrigeration capacity of the freezer and possibly cause damage to the compressor.

## Water Cooled Units

A cold water supply must be provided with a hand shut-off valve. Refer to the "Specifications" section in this manual to identify inlet and outlet water connections for the condensers. (See "Specifications" pages 3 through 10 for proper line sizes.) If there is more than one unit, larger lines should be used. (Flexible lines are recommended if local codes permit.) The water lines must be flushed of foreign substances before connection. Depending on local water conditions, it may be advisable to install a water strainer to prevent foreign substances from clogging the water system. After connecting the inlet water line, install a flexible drain line to an open trap drain. An open trap drain is used so that drain water flow can be observed. Do not install a shut-off valve on the drain line. Incorrect hook-up will result in continuous water flow through the lines.

Recommended water pressure supplied to the unit is 35 PSI (241.3 kPa).

## Electrical Connections

Each freezer requires a dedicated power supply. Check the data label on the freezer for fuse, circuit ampacity and electrical specifications. Refer to the wiring diagram, provided inside the control box, for proper power connections.

In the United States, this equipment is intended to be installed in accordance with the National Electrical Code (NEC), ANSI/NFPA 70-1987. The purpose of the NEC code is the practical safeguarding of persons and property from hazards arising from the use of electricity. This code contains provisions considered necessary for safety. Compliance therewith and proper maintenance will result in an installation essentially free from hazard!

In all other areas of the world, equipment should be installed in accordance with the existing local codes. Please contact your local authorities.

Stationary appliances which are not equipped with a power cord and a plug or other device to disconnect the appliance from the power source must have an all-pole disconnecting device with a contact gap of at least 3 mm installed in the external installation.



**CAUTION: This machine must be properly grounded! Failure to do so can result in severe personal injury from electrical shock!**



**FOLLOW YOUR LOCAL ELECTRICAL CODES!**

## Beater Rotation

Beater rotation must be clockwise as viewed looking into the freezing cylinder.

To correct rotation on a single-phase unit, exchange leads inside the beater motor. (Follow the diagram printed on the motor.)

To correct rotation on a three phase unit, exchange leads at the main terminal block (splice box).



**CAUTION: Make sure the power switch is in the OFF position before correcting the beater rotation. Failure to do so may result in electrocution or component damage.**

Electrical connections are made directly to the terminal block provided in the control box.

# Running Specifications

---

## Pressures/Temperatures

The following are Taylor recommended settings for various components within these models. All freezers in this manual use Refrigerant HP62 (R404A).

### Expansion Valve

#### Soft Serve

Air Cooled - 21 psi. (145 kPa)  
 Water Cooled - 20 to 22 psi. (138 to 152 kPa) for a normal product of 16° to 18°F. (-8.8° to -7.7° C.).

### Expansion Valve Adjustment

Place your gauge on the access valve on the suction line (located at the compressor).

Adjust the pressure higher or lower by turning the adjustment screw. Clockwise turns will raise the pressure and counterclockwise turns will lower the pressure.

**Note:** Make expansion valve adjustments with mix in the cylinder and the freezer in the AUTO mode. Be sure to allow adequate time for the pressure to stabilize.

**Important:** On the Models 336 and 338, expansion valves on each side of the unit must be set separately. Pressures must be set at 4 PSI (28 kPa) lower than what is indicated on the tag.

### Low Side (Suction)

Suction pressure equals the expansion valve setting.

### High Side (Discharge)

High side pressure varies for air cooled units, depending on the ambient temperature.

Ambient Temperature		Normal Operating Head Pressures
F.	C.	PSI
70°	21.1°	240 - 270 (1,655 - 1,862 kPa)
80°	26.7°	270 - 300 (1,862 - 2,069 kPa)
90°	32.2°	300 - 340 (2,069 - 2,344 kPa)
100°	37.8°	340 - 380 (2,344 - 2,620 kPa)

### Water Valve

On a water cooled unit, the water valve should be set to maintain a compressor head pressure of 255 psi. (1,758 kPa).

### Water Valve Adjustment

Place your gauge on the high side access port of the compressor. Turning the adjustment stem on the water valve clockwise will lower the pressure.

**Note:** Make this adjustment with mix in the cylinder and the freezer in the AUTO mode. Be sure to allow adequate time for pressure to stabilize.



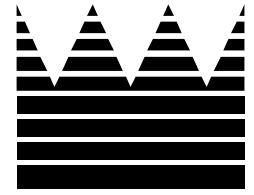

## **Section 2: Controls**

- **Generation II Control Logic Board**
- **Service Tips for Generation II Boards**
- **Control Overview**
- **Pump Operation**
- **Refrigeration Schematic**

# Generation II Control Logic Board

The Generation II logic board's primary function is to interpret modes of operation. The board monitors mix levels and temperatures by sending commands to the control's power board. Commands are sent via a ribbon cable, enabling the proper relays on the power board to open or close. (See illustration on page 22.)

## Function:

Interpret a mode of operation/monitor mix level and temperature/monitor product viscosity or product temperature and send a command to the power board through a ribbon cable enabling the proper relays on the power board to be open or closed.

As of July, 1996 we have modified the differential on Generation II controls from 13°F/7.2°C to 4.5°F/2.5°C in order to meet the new NSF mix temperature requirements. The new control has a shunt (jumper) to select proper temperatures. This shunt is located beneath the dip switches on the left side of the control. The shunt is set in the upper position for 4.5°F/2.5°C differential for use on mix hopper systems and in the lower position for 13°F/7.2°C differential for use on mix cabinet systems. The new control is compatible with older units. This change will require new part numbers as follows:

Old Part No.	New Part No.
X36641-SER Gen. II	X36641SER1
X38523-SER Gen. II-W/Chime	X38523SER1
X41072-SER Gen. II-W/EVC	X41072SER1
X42002-SER Gen. II-Hopper Pump	X42002SER1

## Power Board (Part Numbers):

X32326-SER - Soft Serve  
X34983-SER - Shake

## Logic Board (Part Numbers):

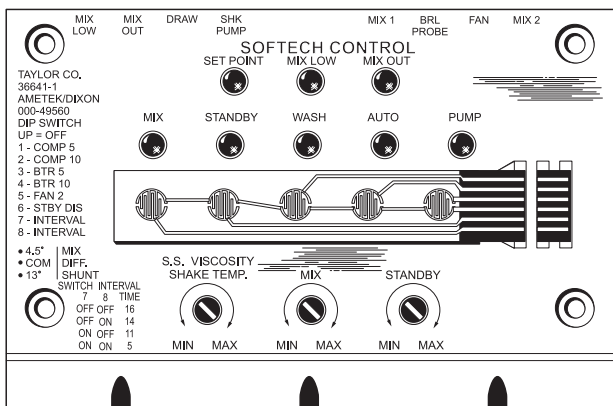

The part number for the Generation I logic board is X32325-SER.

## Thermistor Probes:

There are three types of thermistor probes used on softtech freezers. The resistance value of the thermistor probes corresponds with the temperature. As the temperature becomes warmer, the probe resistance decreases.

- X31602 - Barrel Probe (Senses product in freezing cylinder.)
- X34466 - Hopper Probe (Senses temperature of mix in hopper.)
- X50717 - Hopper (Senses temperature of mix in hopper with new Generation II.)
- X36267 - Cabinet Probe (Senses mix cabinet air temperature.)

## Approximate probe resistance readings:

- 10,000 OHMS at room temperature (77°F/25°C).
- 30,035 OHMS at hopper/cabinet temperature (35°F/2°C).
- 38,830 OHMS at shake temperature (26°F/-3.3°C).
- 48,636 OHMS at soft service temperature (18°F/-7.7°C).

## Viscosity Function:

In soft serve freezers the logic board monitors amp draw on the beater motor, which is directly related to the viscosity of the product in the freezing cylinder. When the amp draw reaches its set point, the unit cycles off. Therefore, the viscosity of the product will always be consistent even through its temperature may vary slightly.

To monitor amperage, L1 power supplied to the beater motor must pass through the power board beater terminals. The same softech controls are used in both single and three phase applications. For this reason the control must be set to operate in an amperage range which relates to the beater motor amperage and the desired product viscosity setting.

The selected amperage range simply determines the adjustment span of the viscosity adjustment potentiometer on the logic board. The jumper on the power board determines the amperage range selection. The jumper is placed on the pin which corresponds to the beater motor amperage when the desired product viscosity is attained. See page 22 to locate the range selection jumper.

## Viscosity Control Range Selections:

- 2.4 PIN - 1.2 AMP to 2.4 AMP
- 5.0 PIN - 2.5 AMP to 5.0 AMP
- 8.0 PIN - 4.0 AMP to 8.0 AMP
- 11.2 PIN - 5.7 AMP to 11.2 AMP

## Setting Viscosity Adjustment:

1. Place an amp probe on one of the L1 leads on the beater terminal on the power board.
2. Turn the viscosity adjustment screw to the "MAX" position.
3. With the freezer properly primed, actuate the refrigeration cycle (press "AUTO").
4. During the freezing process, draw a sample and inspect the product appearance. When desired product viscosity and appearance is achieved, note the beater motor amperage.
5. Cancel the refrigeration cycle (press "AUTO").
6. Using the chart, set what range the beater motor amperage falls into and place the jumper on the proper pin. (**Note:** See chart above for amperage range.)

7. Press "AUTO". When amperage achieves the previously noted beater motor amperage, turn the viscosity adjustment screw counterclockwise **slowly** until the unit cycles off.
8. Draw several samples to verify that the amperage at cycle off and product quality remains consistent.

## Mix Adjustment:

The mix setting is the temperature adjustment for the mix cabinet or the mix hopper.

Ideal mix temperature = 38°F (3.3°C) to 40°F (4.4°C).

Cut-out temperature will always be 13°F (7.2°C) (cabinet) / 4.5°F (2.5°C) (hopper) lower than the cut-in temperature. (See SB 2474.)

The range for cut-in temperature is "MIN" approximately 52°F (11.0°C) and "MAX" approximately 36°F (2.2°C).

## Setting the Mix Cabinet Temperature:

1. Place a thermometer in the cabinet close to the thermistor probe.
2. Turn the mix adjustment screw all the way to "MAX".
3. When the air temperature in the cabinet reaches 30°F to 31°F (-1.1°C), turn the mix adjustment screw counterclockwise until the mix refrigeration cycles off.
4. Allow the mix temperature to stabilize and adjust the setting if necessary.

## Setting the Mix Hopper Temperature

1. To set the mix hopper temperature, fill the hopper at least half full with approximately 40°F (4.4°C) mix.
2. Install a suction pressure gauge at the EPR valve (evaporator pressure regulator) and verify the correct operating pressure. Adjust if necessary.
3. Set the "MIX" potentiometer to mid-range.
4. Allow the mix hopper refrigeration system to cycle until the mix temperature is stabilized. Adjust the setting if necessary.

**Note:** On the Models 336, 338, 339, 754 and 794, the temperature adjustment must be made on the left logic board.

## Standby Adjustment

Maintains mix temperature in the freezing cylinder during long "no sale" periods to prevent over-beating of the product.

Ideal standby temperature = 30°F (1.1°C) to 35°F (1.7°C).

Cut-out temperature will always be 4°F (2°C) lower than the cut-in temperature.

The range for cut-in temperature is "MIN" approximately 44°F (6.6°C) and "MAX" approximately 30°F (-1.1°C).

## Setting Standby Temperatures

1. With the unit properly primed with fresh mix, turn the STANDBY adjustment screw to the warmest position.
2. Press "STANDBY".
3. When the main refrigeration system cycles off, draw a sample portion and check the product temperature.
4. To get the desired standby temperature, make a slight clockwise adjustment and wait until the main refrigeration cycles off.

**Note:** On pump units, "STANDBY" must be cancelled and "PUMP" must be pressed to replace the portion which was used for the sample draw.

## Thermistor Curve

When checking a thermistor probe, first determine the present temperature at the probe and find it on this chart along with the approximate correct ohmmeter reading. The ohmmeter reading may vary from the

correct one. Determine whether the difference is acceptable. If a probe is actually faulty, the difference will be great.

F.°	C.°	K OHM
-10	-23.3	118.201
-9	-22.7	114.394
-8	-22.2	110.709
-7	-21.6	107.143
-6	-21.1	103.692
-5	-20.5	100.352
-4	-20.0	97.120
-3	-19.4	94.085
-2	-18.8	91.144
-1	-18.3	88.296
0	-17.7	85.536
1	-17.2	82.863
2	-16.6	80.273
3	-16.1	77.765
4	-15.5	75.334
5	-15.0	72.980
6	-14.4	70.627
7	-13.8	68.350
8	-13.3	66.147
9	-12.7	64.014
10	-12.2	61.951
11	-11.6	59.953
12	-11.1	58.021
13	-10.5	56.150
14	-10.0	54.340
15	-9.4	52.854
16	-8.8	51.409
17	-8.3	50.003
18	-7.7	48.636
19	-7.2	47.306
20	-6.6	46.012
21	-6.1	44.754
22	-5.5	43.530

F.°	C.°	K OHM
23	-5.0	42.340
24	-4.4	41.136
25	-3.8	39.967
26	-3.3	38.830
27	-2.7	37.727
28	-2.2	36.654
29	-1.6	35.612
30	-1.1	34.599
31	-0.5	33.616
32	0	32.660
33	0.5	31.760
34	1.1	30.885
35	1.6	30.035
36	2.2	29.207
37	2.7	28.403
38	3.3	27.620
39	3.8	26.859
40	4.4	26.120
41	5.0	25.400
42	5.5	24.721
43	6.1	24.059
44	6.6	23.416
45	7.2	22.789
46	7.7	22.180
47	8.3	21.586
48	8.8	21.009
49	9.4	20.447
50	10.0	19.900
51	10.5	19.884
52	11.1	18.881
53	11.6	18.392
54	12.2	17.915
55	12.7	17.451

F.°	C.°	K OHM
56	13.3	16.998
57	13.8	16.557
58	14.4	16.128
59	15.0	15.710
60	15.5	15.315
61	16.1	14.929
62	16.6	14.554
63	17.2	14.187
64	17.7	13.830
65	18.3	13.482
66	18.8	13.143
67	19.4	12.812
68	20.0	12.490
69	20.5	12.185
70	21.1	11.888
71	21.6	11.598
72	22.2	11.315
73	22.7	11.039
74	23.3	10.769
75	23.8	10.507
76	24.4	10.250
77	25.0	10.000
78	25.5	9.763
79	26.1	9.532
80	26.6	9.306
81	27.2	9.085
82	27.7	8.870
83	28.3	8.659
84	28.8	8.454
85	29.4	8.254
86	30.0	8.058
87	30.5	7.872
88	31.1	7.691
89	31.6	7.513
90	32.2	7.340
91	32.7	7.171
92	33.3	7.006
93	33.8	6.884
94	34.4	6.686

F.°	C.°	K OHM
95	35.0	6.532
96	35.5	6.386
97	36.1	6.242
98	36.6	6.102
99	37.2	5.966
100	37.7	5.832
103	39.4	5.448
106	41.1	5.096
109	42.8	4.769
112	44.4	4.466
115	46.1	4.184
118	47.8	3.922
121	49.4	3.680
124	51.1	3.454
127	52.8	3.244
130	54.4	3.048
133	56.1	2.866
136	57.8	2.696
139	59.4	2.539
142	61.1	2.391
145	62.8	2.252
148	64.4	2.124
151	66.1	2.004
154	67.8	1.891
157	69.4	1.785
160	71.1	1.687
163	72.8	1.594
166	74.4	1.508
169	76.1	1.427
172	77.8	1.351
175	79.4	1.279
178	81.1	1.212
181	82.8	1.149
184	84.4	1.090
187	86.1	1.034
190	87.8	.982
193	89.4	.932
196	91.1	.886
199	92.8	.842

# Service Tips for Generation II Boards

## Initial Service Tips

1. Check all connections.
2. Check the cable to verify that it is secure.
3. Verify that all pins are securely fastened in their sockets.
4. Verify that all cables correctly face away from the boards. If the cable is attached incorrectly, damage to the logic board will occur. Air/mix pump and beater motor operation will be disabled.
5. Verify probe resistance.
6. Use the self-test program.

## Self-Test Program

The Generation II controls are programmed for a self-test. The control can be used to help identify problems in the power board, the logic board, and the thermistor probes. The self-test program is not intended to, and will not take the place of a reasonable, and prudent service technician.

The self-test program is divided into two sections. The first section is an automatic function of the micro processor and the second section is performed by the technician.

The self-test program is initiated by holding down the MIX, WASH, AND PUMP keypads on the logic panel while simultaneously turning on the power switch. Hold down the keypads until all eight lights illuminate. If all eight lights do not illuminate, the control is defective. If the self-test cannot be initiated, the control is defective.

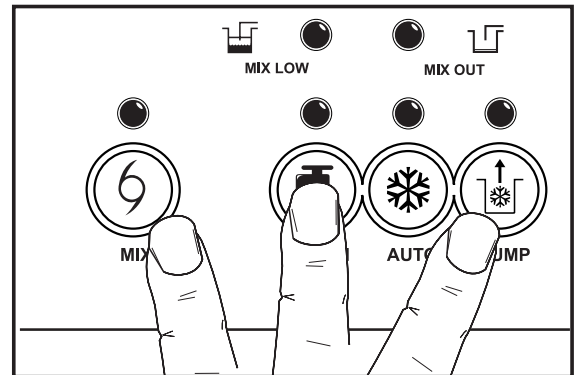

Figure 1.

Each light corresponds with a particular relay. The light on the panel will not extinguish until the test is completed for that particular relay.

Logic Panel Light	Corresponding Relay
MIX LOW	Mix Relay
MIX OUT	Fan Relay
MIX	Pump Relay
STANDBY	Beater Motor Relay
WASH	Compressor Relay
AUTO	Spinner Relay
PUMP	Portion Relay

In each of the tests the relay on the power board will close and the component will operate for three seconds. There is a ten second delay between each check.

When the self-test is initiated, all eight lights will remain on for three seconds. At this time, the processor will begin to check the power board relays as follows:

1. The SET POINT light turns off.
2. Ten seconds after the SET POINT light turns off, the mix relay closes for three seconds.
3. The mix relay opens and the MIX LOW light turns off.
4. Ten seconds later, the fan relay closes.
5. Three seconds later, the fan relay opens and the MIX OUT light turns off.

6. Ten seconds later, the pump relay closes.
7. Three seconds later, the pump relay opens and the mix light turns off.
8. Ten seconds later, the beater motor relay closes.
9. Three seconds later, the beater motor relay opens and the STANDBY light turns off.
10. Ten seconds later, the compressor relay closes.
11. Three seconds later, the compressor relay opens and the wash light turns off.
12. All lights are off and a tone sounds for three seconds. This designates the end of the first section.

If all or most of the power board relays fail to close, the logic panel is defective. If only one relay fails to close, the power board is defective. This test can be used to determine if a problem exists with the logic panel, the power board, or elsewhere in the freezer. In other words, if during the test the beater relay closes on the power board, but the beater motor contactor does not operate, the problem occurs after the command reaches the power board.

## Self-Test - Part II

When the first section of the self-test is complete, the control will advance to the starting point of the second section. The technician will have to complete this portion of the test. The first part of this section verifies the function of the control potentiometers (adjustment screw).

During this test, the MIX, STANDBY, WASH, AUTO, and PUMP lights function in direct relationship with the "MIN" and "MAX" adjustments of the potentiometer. In other words, when the adjustment screw is turned all the way to "MIN", the MIX light will be lit. When the adjustment is turned all the way to "MAX", the PUMP light will be lit. If the screw adjustment is made between the "MAX" and the "MIN" adjustment, one of the other lights will illuminate depending on the adjustment.

These lights create a bar graph which is directly related to the product temperature. "MIX" is warm and "PUMP" is cold.

1. The SET POINT light is lit, indicating that the control is reading the soft serve viscosity potentiometer.
2. Rotate the adjustment screw back and forth from "MIN" to "MAX". The bar graph should travel accordingly. This indicates that the potentiometer is functional.

If the bar lights do not react, the logic panel is defective.



**Important:** If the freezer's controls have been set previously, return the adjustment to its original position. For example, if the WASH light was lit before an adjustment screw was rotated, before going to the next step, rotate the adjustment screw until the WASH light is lit again.

3. Press the MIX keypad once.
4. The MIX LOW light is lit, indicating that the control is reading the MIX potentiometer.
5. Rotate the adjustment screw as in Step 2.
6. Press the MIX keypad once.
7. The MIX OUT light is on, indicating the control is reading the STANDBY potentiometer.
8. Rotate the adjustment screw as in Step 2.
9. Press the MIX keypad once.
10. The MIX LOW light is lit, indicating that the control is reading the "MIX 1" terminal.



11. The capability of this terminal to read the thermistor probe can be checked by the following method:
  - a. Remove the thermistor probe wire from the "MIX 1" terminal.
  - b. Connect the "MIX 1" terminal directly to ground (simulating a warm probe). The MIX light will illuminate.
  - c. Remove the terminal connection from ground (simulating a cold probe). The PUMP light will illuminate.

If the lights do not react, the panel is defective.

12. Press the MIX keypad once.
13. The MIX OUT light is lit, indicating that the control is now reading the BARREL (freezing cylinder) probe terminal.
14. Check the freezing cylinder probe (as in Step 11.) by removing the wire from the panel.
15. Press the MIX keypad again, and the self-test program is terminated.

# Control Overview

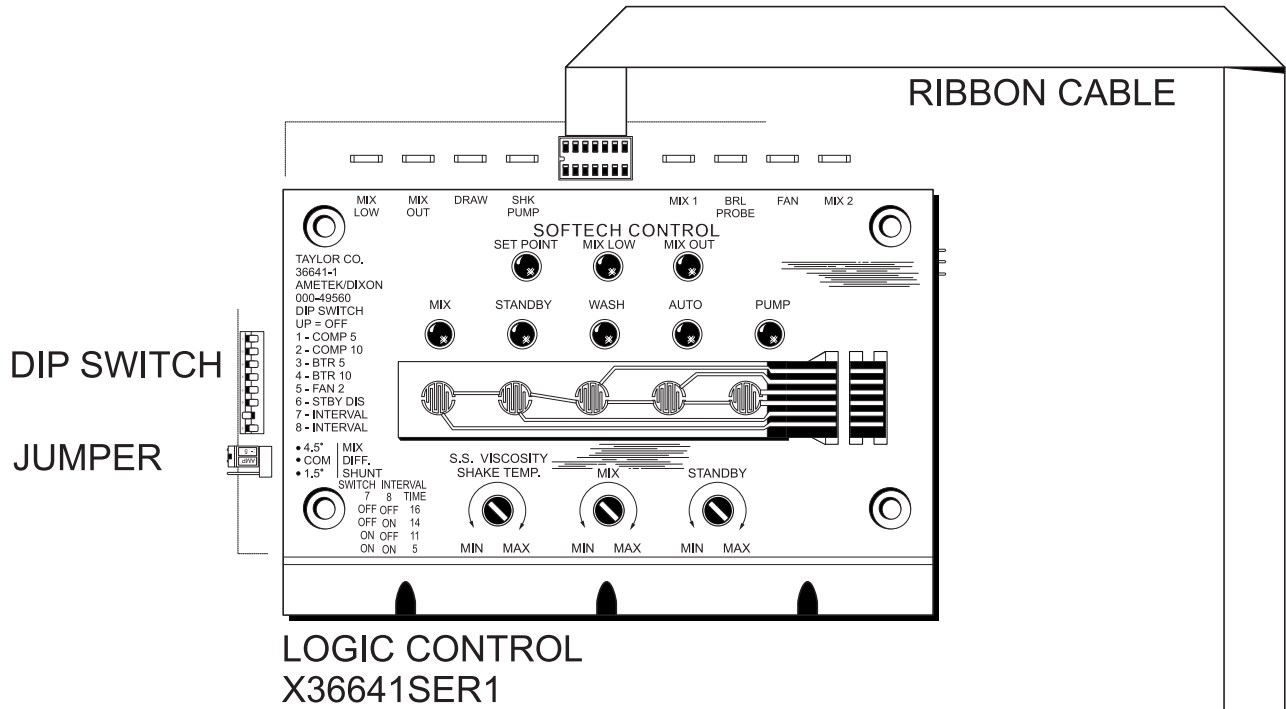

**POWER BOARD X32326-SER**

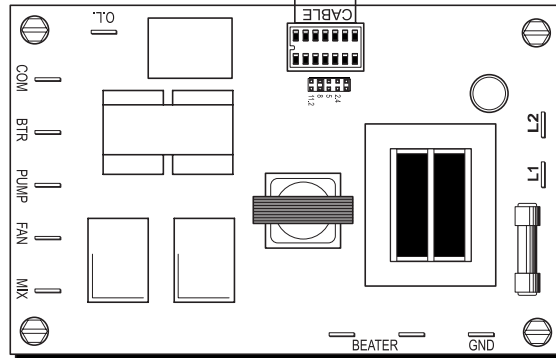

# Pump Operation

The pump operates under the following conditions:

## Pump Key

When the PUMP key is pressed, the pump is active by itself or with the WASH mode of operation.

## Soft Serve Mix Pumps

The soft serve mix pump will be active for 30 seconds whenever the AUTO mode is entered. If a MIX OUT condition forces a side of the machine into the STANDBY mode of operation, the mix pump will not be active.

## Mix Pump Draw Timer

During the AUTO mode, the mix pump will operate for 10 seconds after every draw of soft serve product.

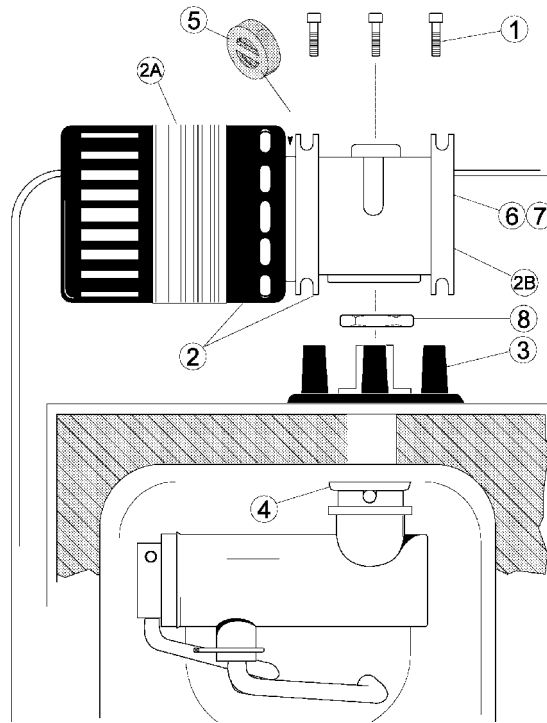

ITEM	DESCRIPTION	PART NO.
1	SCREW-1/4-20 x 3/4	020128-2
2	MOTOR-REDUCER (50/60)	036955-34
2A	MOTOR	049246-34
2B	GEAR (50/60 HZ)	049247-34
3	MOUNT-MOTOR	036934
4	SLEEVE A.-MIX PUMP- PH71, 8751, 8754	X45012

ITEM	DESCRIPTION	PART NO.
5	COUPLING-MOTOR-FLEXIBLE	047936
6*	SEAL-INPUT	048836
7*	SEAL-OUTPUT	048837
8	NUT-PUMP SLEEVE	036933

\*NOT SHOWN

# Refrigeration Schematic

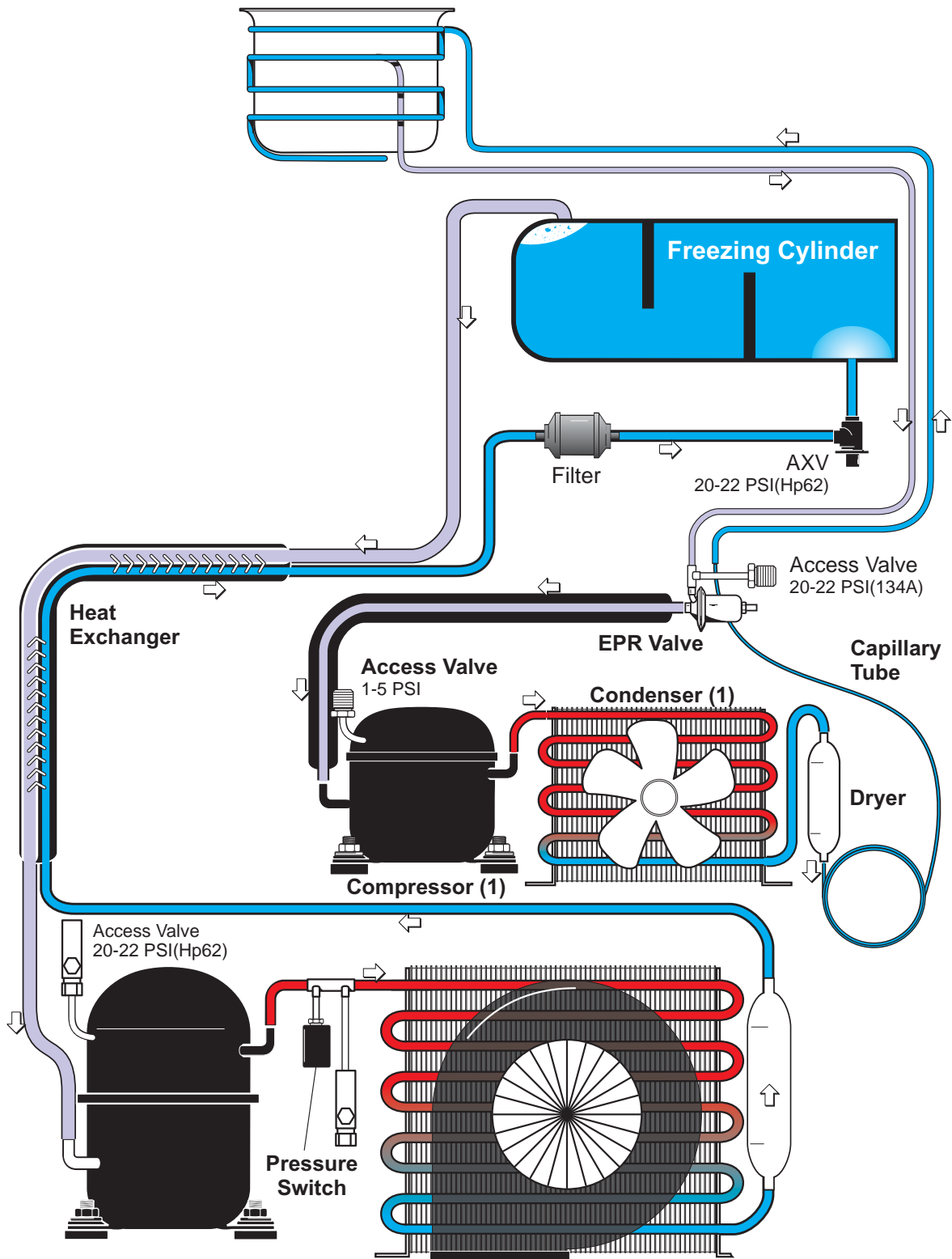

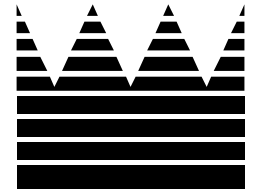

## **Section 3: Troubleshooting**

- **General Troubleshooting Guide**
- **Troubleshooting Pump Style Freezers**
- **Electrical Troubleshooting**

# General Troubleshooting Guide

PROBLEM	PROBABLE CAUSE	REMEDY
1. No product is being dispensed.	Low on mix. The MIX OUT light is on.	Add mix to the mix hopper
	The power switch is in the OFF position.	Place the power switch to the ON position and press the AUTO keypad.
	Beater motor is out on reset.	Allow the beater motor to cool. Place the power switch to the OFF position. Press the reset button firmly. Place the power switch to the ON position and press the WASH keypad. Open the side access panel and observe that the drive shaft is turning CLOCKWISE as viewed from the front of the unit. Press the AUTO keypad to return to the AUTO mode.
	Air/mix pump is incorrectly assembled or improperly lubricated.	Follow assembly procedures carefully.
	Missing or incorrectly installed spring and poppet in air/mix pump.	Replace or correctly install the spring and poppet on the mix inlet fitting.
	The mix pump ball crank is broken.	Replace the component.
	The pump motor is not activated.	Push the reset button. The draw valve must be fully raised to activate the pump motor.
	Incorrect usage of the mix feed tube (gravity style freezers).	Follow the correct feed tube procedures and use of the air orifice.
2. The product is too thick.	Insufficient mix in the freezing cylinder.	Check the air/mix pump assembly. The mix inlet tube must be fully submerged in mix.
	Improper priming procedures.	Drain the freezing cylinder and re-prime the unit.
	The air/mix pump is incorrectly assembled.	Follow assembly procedures carefully.
	The viscosity control is set too cold.	Adjust the viscosity.

<b>PROBLEM</b>	<b>PROBABLE CAUSE</b>	<b>REMEDY</b>
3. The product is too soft.	The draw rate is set too fast.	Adjust the draw rate to 5 - 7-1/2 oz. (142 g. - 213 g.) of product by weight every 10 seconds.
	Outdrawing the capacity of the freezing cylinder.	The continuous draw rate is approximately 15 cones.
	There is inadequate air space around the unit.	A minimum of 3 " (7.6 cm.) of clearance around all sides is required. Exception: The minimum requirement for the 338 and 750 is 6" (15.2 cm.).
	Dirty condenser or air filters on air cooled units.	Clean regularly.
	Inadequate water supply on water cooled units.	Check the water supply. Check the water lines for leaks or kinks.
	Bad scraper blades.	Replace the scraper blades.
	The viscosity control is set too warm.	Adjust the viscosity.
4. The mix in the hopper is too warm.	Incorrect usage of the mix feed tube (gravity style freezers).	Follow the correct feed tube procedures and use of the air orifice.
	The hopper cover is not in position.	Clean the hopper cover and place it in position.
5. The mix in the hopper is too cold.	The hopper temperature is out of adjustment.	Adjust the temperature control.
	The hopper temperature is out of adjustment.	Adjust the temperature control.
6. Product is collecting on top of the freezer door.	The top o-ring on the draw valve is improperly lubricated or worn.	Lubricate properly or replace the o-ring.
7. Excessive mix leakage from the bottom of the door spout.	The bottom o-ring on the draw valve is improperly lubricated or worn.	Lubricate properly or replace the o-ring.
8. Excessive mix leakage into the long drip pan.	The seal on the drive shaft is improperly lubricated or worn.	Lubricate properly or replace the seal.
	The seal is installed inside-out on the drive shaft.	Install the seal correctly.
9. Excessive mix leakage from the rear of the freezer into the short drip pans.	Worn or missing o-rings on the pump drive shaft.	Install or replace the o-rings.
	Inadequate lubrication of the drive shaft.	Lubricate properly.
	The drive shaft and beater assembly work forward.	Verify the refrigerant charge and check for a shorted freezing cylinder.
	Worn rear shell bearing.	Replace the component.
	Gear box out of alignment.	Re-align the gear box.
10. The drive shaft is stuck in the drive coupling.	Mix and lubricant have collected in the drive coupling.	Brush clean the rear shell bearing area regularly.
	Rounded corners of the drive shaft, the drive coupling or both.	Replace worn component(s).
	The gear box is out of alignment.	Re-align the gear box.

PROBLEM	PROBABLE CAUSE	REMEDY
11. Freezing cylinder walls are scored.	Missing or worn front bearing.	Install or replace the front bearing.
	Broken beater pins (pump style freezers, only).	Replace the beater assembly. When installing scraper blades, be sure they are properly attached over the pins.
	The beater assembly is bent.	The beater assembly must be replaced.
	The gear box is out of alignment.	Re-align the gear box.
12. The pump will not operate in the PUMP mode.	The pump motor is not activated.	Push the reset button.
	The membrane switch is defective.	Replace the switch.
13. The unit will not run when in the AUTO mode.	The unit is unplugged.	Plug into wall receptacle.
	The beater motor is out on reset.	Allow the beater motor to cool. Place the power switch to the OFF position. Press the reset button firmly. Place the power switch to the ON position, and press the WASH keypad. Open the side access panel and observe that the drive shaft is turning clockwise as viewed from the front of the unit. Press the AUTO keypad to return to the AUTO mode. <b>Note:</b> Do not use metal objects to press the reset button.
	The circuit breaker is off, or the fuse is blown.	Turn the breaker on, or replace the fuse.
	Low on mix. The MIX OUT light is on.	Add mix to the mix hopper and press the AUTO keypad.
	The water is turned off, on water cooled units.	Turn the water on.
14. Product is not feeding into the freezing cylinder.	The mix inlet hole is frozen up.	The hopper temperature needs adjustment.
	Incorrect usage of the mix feed tube (gravity style freezers).	Follow the correct feed tube procedures and use of the air orifice.
15. Product is "popping" when drawn.	The draw rate is set too fast.	The draw rate should be set at 5 - 7-1/2 oz. of product per 10 seconds.
	The pump is assembled incorrectly.	Assemble and lubricate according to instructions in the Operator's manual.
16. The MIX LOW and MIX OUT probes are not functioning.	There is milkstone build-up in the hopper.	Clean the hoppers thoroughly.



# Troubleshooting Pump Style Freezers

PROBLEM	PROBABLE CAUSE	REMEDY
1. The air/mix pump will not operate when the PUMP keypad is pressed.	The circuit breaker is off.	Check the breaker.
	The power cord is unplugged.	Plug in the power cord.
	The freezer is out on reset.	Reset the freezer.
	The pump motor is out on reset.	Press the PUMP keypad to cancel the pump operation. Press the reset button on the side of the pump motor reducer. Press the PUMP keypad to continue pump operation.
2. The air/mix pump will not operate when the draw valve is opened and the unit is in the AUTO mode.	The pump motor is out on reset.	Press the PUMP keypad to cancel the pump operation. Press the reset button on the side of the pump motor reducer. Press the PUMP keypad to continue pump operation.
	The pump motor relay is malfunctioning.	Replace the relay.
3. The piston travels back and forth, but product is not being pumped.	Inspect the check bands.	The check bands must be installed correctly, fit tightly, and not have any holes or lubrication.
	Inspect the o-rings.	O-rings must not be worn, torn, or fit too loosely.
	Check the pump cylinder.	The piston and liquid valve body must be assembled correctly, and fit snugly in the pump cylinder.
	The spring or poppet is missing or defective.	Replace.
4. Excessive pump cylinder wear.	Inadequate or incorrect lubrication of pump cylinder.	Follow lubrication procedures carefully.
	Incorrect ball crank rotation. (Must be counterclockwise).	Reverse pump rotation.
5. Pitting occurring inside the pump cylinder.	Cleaner was left inside the pump cylinder.	After brush cleaning the pump cylinder, allow it to dry. Follow disassembly procedures carefully.
6. The ball crank of the motor reducer is broken.	Incorrect rotation of pump motor.	Reverse pump rotation.
7. Too much pressure is in the freezing cylinder.	Plugged relief hole in the liquid valve body below the poppet.	Clean.
8. Not enough pressure is in the freezing cylinder.	The spring in the liquid valve body is weak or bent.	Replace.
	The draw switch is malfunctioning.	Replace the draw switch.
	The poppet is missing.	Install the poppet.

# Electrical Troubleshooting

---

The following information provides a sequential list of electrical components that L-1 power travels through to initiate various operations.

## **Auto Mode of Operation:**

L-1 power travels through the power switch, beater overload switch, the compressor high pressure cut-out switch, the overload terminal (OL) on the power board, the BTR terminal of the power board, and energizes the coil of the beater motor contactor.

L-1 power travels through the power switch, beater overload switch, the compressor high pressure cut-out switch, the overload terminal (OL) on the power board, the COM terminal of the power board, and energizes the coil of the compressor contactor.

L-1 power travels through the power switch, beater overload switch, the compressor high pressure cut-out switch, the L-1 terminal of the power board, the MIX terminal of the power board, and energizes the hopper refrigeration compressor and condenser fan.

## **Wash Mode of Operation:**

L-1 power travels through the power switch, beater overload switch, the compressor high pressure cut-out switch, the overload terminal (OL) on the power board, the BTR terminal of the power board, and energizes the coil of the beater motor contactor.

## **Pump Mode of Operation:**

L-1 power travels through the power switch, beater overload switch, the compressor high pressure cut-out switch, the overload terminal (OL) on the power board, the PUMP terminal of the power board, and energizes the coil of the pump motor.

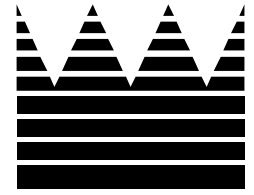

## **Section 4: Parts**

- **Warranty Explanation**
- **Exploded Views**
- **Complete Parts List**
- **Wiring Diagrams**

# Warranty Explanation

---

- Class 103 Parts:** The warranty for new equipment parts is one year from the original date of unit installation, with a replacement parts warranty of three months.
- Class 212 Parts:** The warranty for new equipment parts is two years from the original date of unit installation, with a replacement parts warranty of twelve months.
- Class 512 Parts:** The warranty for new equipment parts is five years from the original date of unit installation, with a replacement parts warranty of twelve months.
- Class 000 Parts:** Wear Items - no warranty.

**CAUTION:** Warranty is valid only if required service work is provided by an Authorized Taylor Service Technician.

**NOTE:** Taylor reserves the right to deny warranty claims on equipment or parts if a non-approved refrigerant was installed in the machine, system modifications were performed beyond factory recommendations, or it is determined that the failure was caused by neglect or abuse.

## Compressor Warranty Disclaimer

---

The refrigeration compressor(s) on this machine are warranted for the term indicated on the warranty card accompanying this machine. However, due to the Montreal Protocol and the U.S. Clean Air Act Amendments of 1990, many new refrigerants are being tested and developed; thus seeking their way into the service industry. Some of these new refrigerants are being advertised as drop-in replacements for numerous applications. It should be noted that, in the event of ordinary service to this machine's refrigeration system, only the refrigerant specified on the affixed data label should be used. The unauthorized use of alternate refrigerants will void your compressor warranty. It will be the owners' responsibility to make this fact known to any technicians they employ.

It should be noted, that Taylor does not warrant the refrigerant used in its equipment. For example, if the refrigerant is lost during the course of ordinary service to this machine, Taylor has no obligation to either supply or provide its replacement either at billable or unbillable terms.

The Taylor Company will continue to monitor the industry and test new alternates as they are being developed. Should a new alternate prove, through our testing, that it would be accepted as a drop-in replacement, then the above disclaimer would become null and void. To find out the current status of an alternate refrigerant as it relates to your compressor, call the local Taylor Distributor or the Taylor Factory. Be prepared to provide the model/serial number of the unit in question.



# Model 336 Exploded View

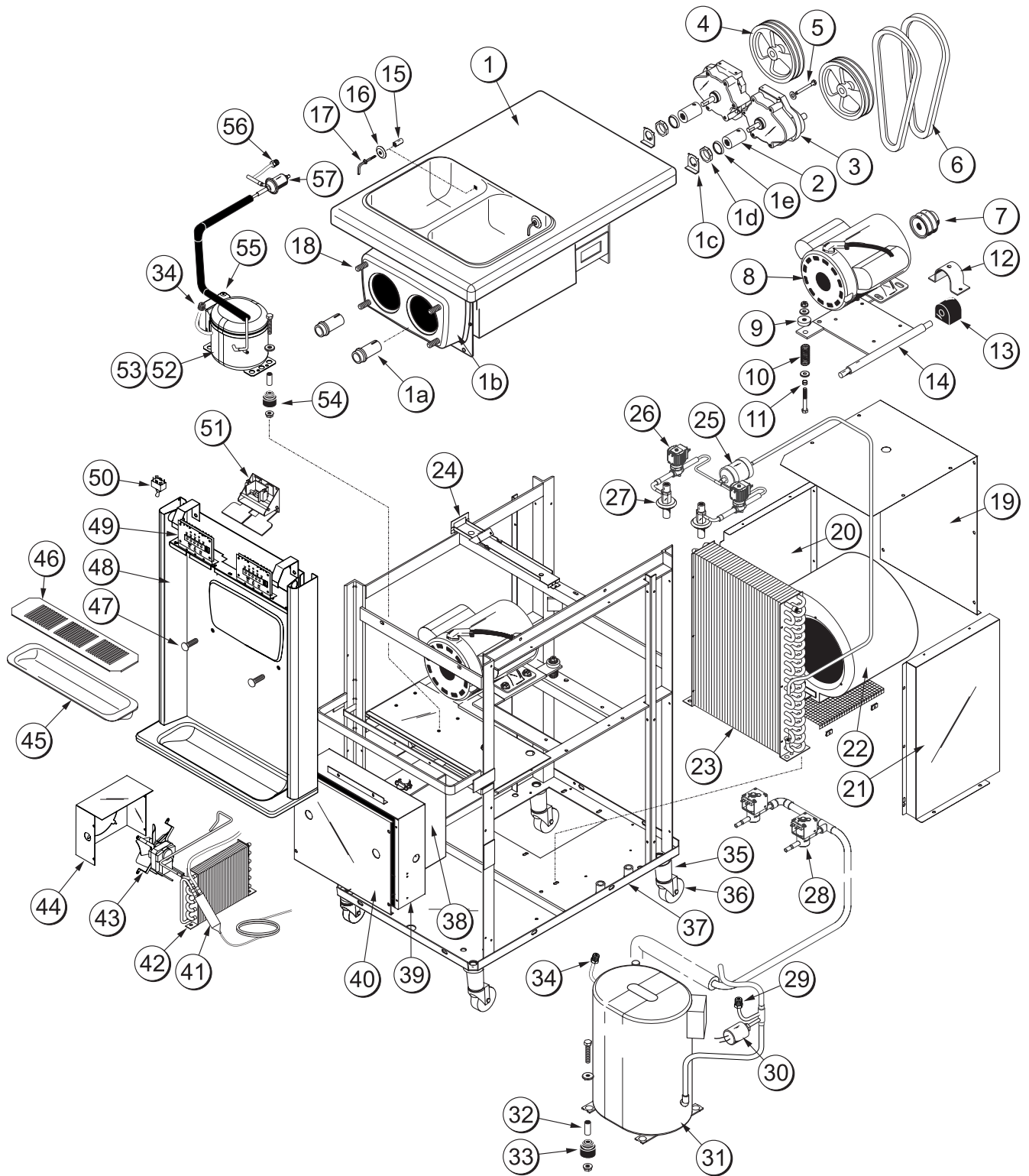

## Model 336 Exploded View

ITEM	DESCRIPTION	PART NO.
1	SHELL A.-INSULATED	X52982-SP
1a	BEARING-REAR SHELL	031324
1b	CONE-NOSE	N/A
1c	WASHER-BEARING LOCK	012864
1d	NUT-BRASS BEARING	028991
1e	GUIDE-DRIP SEAL	028992
2	COUPLING-DRIVE 3/4 HEX	012721
3	GEAR A.*REDUCER 4.21:1	021286
4	PULLEY-2AK64-5/8 BORE	039695
5	SCREW-5/16-18 X 3 HEX CAP	009497
6	BELT-AX38	023873
7	PULLEY-2AK20 X 5/8 BORE	034238
8	MOTOR-1.0 HP	013102-
9	GROMMET-7/16 X 5/16	016212
10	SPRING-COMP.970X.115X2.0	025707
11	CAP-RUBBER MOUNT	011844
12	CLAMP-MOUNTING	012257
13	BUSHING-MOUNTING	012258
14	HINGE A.-MOTOR	X29341
15	SPACER-PROBE *SQ HOLE	030966
16	DISC-PROBE *SQ HOLE*	030965
17	PROBE A.-MIX SQUARE	X30922
18	STUD-NOSE CONE	022822
19	SHROUD-TOP PANEL	013820
20	SHROUD-LEFT	013821
21	SHROUD-RIGHT	013822
22	BLOWER A.	X53725-
23	CONDENSER-AC	048233
24	GUIDE A.-DRIP PAN	X27554
25	DRYER-FILTER-HP62	048901
26	VALVE-SOLENOID 7/64ORF	043449-27
27	VALVE-EXP-AUTO-1/4S	046365
27a	BOOT-EXPANSION VALVE	050900

ITEM	DESCRIPTION	PART NO.
28	VALVE-SOLENOID 7/16 ORF	048626-27
29	LINE A.-ACCESS-COMP.	X42513
30	SWITCH-PRESSURE 440 PSI	048230
31	COMPRESSOR L63A113BBCA	048259-
32	SLEEVE-COMP. MOUNTING	037429
33	GROMMET-COMP. MT	037428
34	VALVE-ACCESS-1/4 MFL	047016
35	ADAPTOR A.-CASTER	X18915
36	CASTER-SWV 5/8 STEM 4IN	018794
37	FRAME A.	N/A
38	BOX A.-CAP & RELAY	X48535-
39	CONTROL A.	SEE PG. 68
40	COVER-CONTROL BOX	036538
41	DRYER-CAP. TUBE .026 ID	047699
42	CONDENSER-AC-7X6X1.25	027155
43	MOTOR-FAN 105CFM	027309-27
44	SHROUD-DANFOSS	027386
45	TRAY-DRIP 16-7/8L X 5-1/8	020157
46	SHIELD-SPLASH	022765
47	BOLT-CARRIAGE	012347
48	PANEL A.-FRONT	X42821-SP1
49	BOARD-LOGIC-GEN 2.6-SD	X36641SER1
50	SWITCH-TOGGLE-4PDT	037394
51	SWITCH A.-DRAW	SEE PG. 84
52	COMPRESSOR TL3G-R134A	047701-27
53	RELAY-START-COMP.	047702-27
54	KIT-MOUNTING-COMP.	047704
55	CAPACITOR-START	047703
56	VALVE-ACCESS 1/4FL	044404
57	VALVE-EPR 1/4S	022665
*58	DEFLECTOR-BLOWER EXHAUST	048345

\*NOT SHOWN

# Model 336 Panel Identification

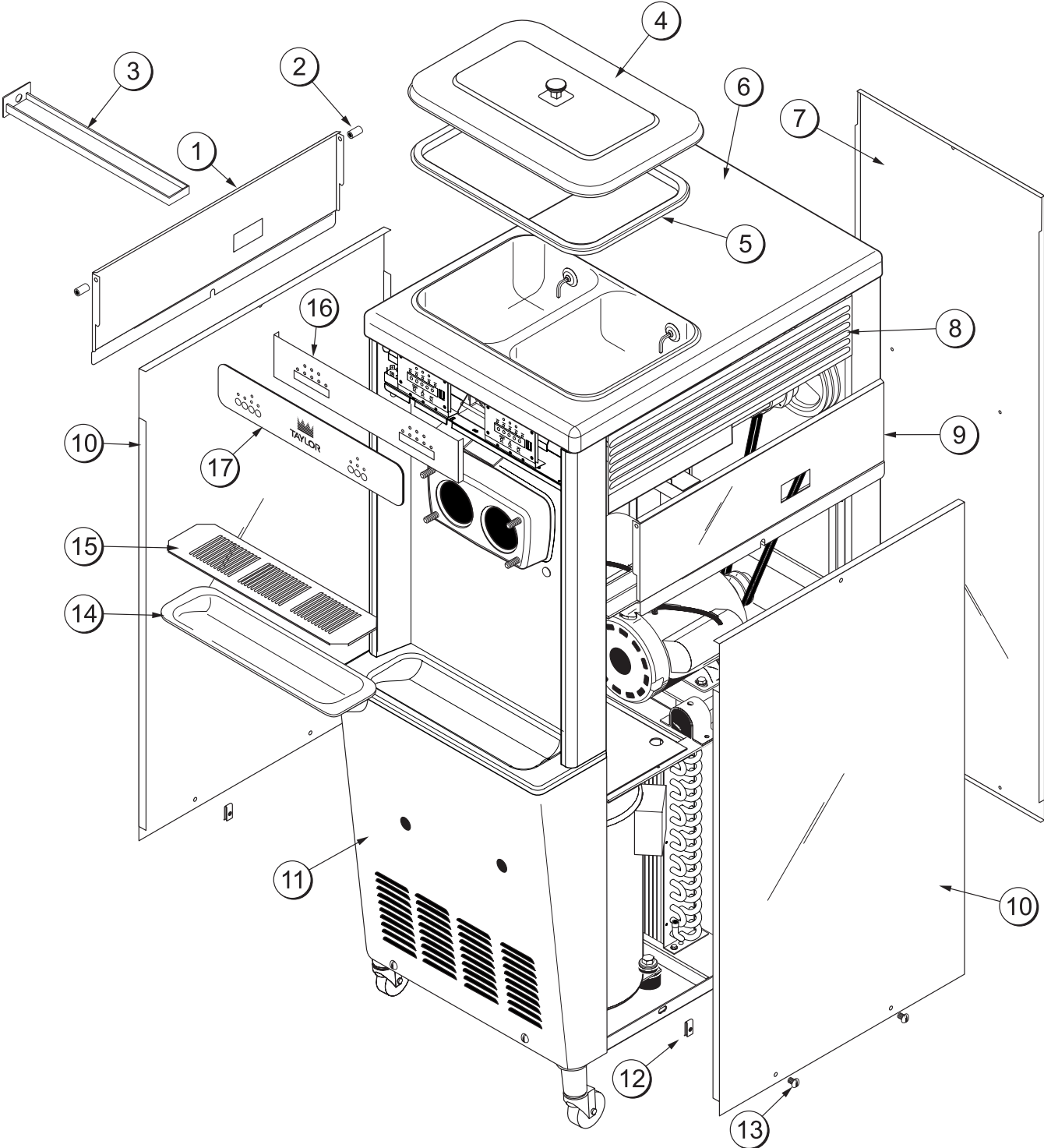



### Model 336 Panel Identification

ITEM	DESCRIPTION	PART NO.
1	PANEL-UPPER SIDE LEFT	028740
2	BUSHING-PANEL	013289
3	PAN-DRIP 17-1/4" LONG	027504
4	COVER A. - HOPPER	X37963-SER
5	GASKET-HOPPER COVER	037042
6	HOOD	041026
7	PANEL-REAR	029816
8	LOUVER-SIDE	017471
9	PANEL-UPPER SIDE RIGHT	028741

ITEM	DESCRIPTION	PART NO.
10	PANEL A.-LOWER SIDE	X24424-SER
11	PANEL-SERVICE	042824
12	FASTENER-CLIP 1/4-20 U	045865
13	SCREW-1/4-20X3/8 RHM-SS	011694
14	TRAY-DRIP 16-7/8L X 5-1/8	020157
15	SHIELD-SPLASH	022765
16	PLATE-DEC	038081
17	DECAL-DEC-TAYLOR	038337

# Model 338 Exploded View

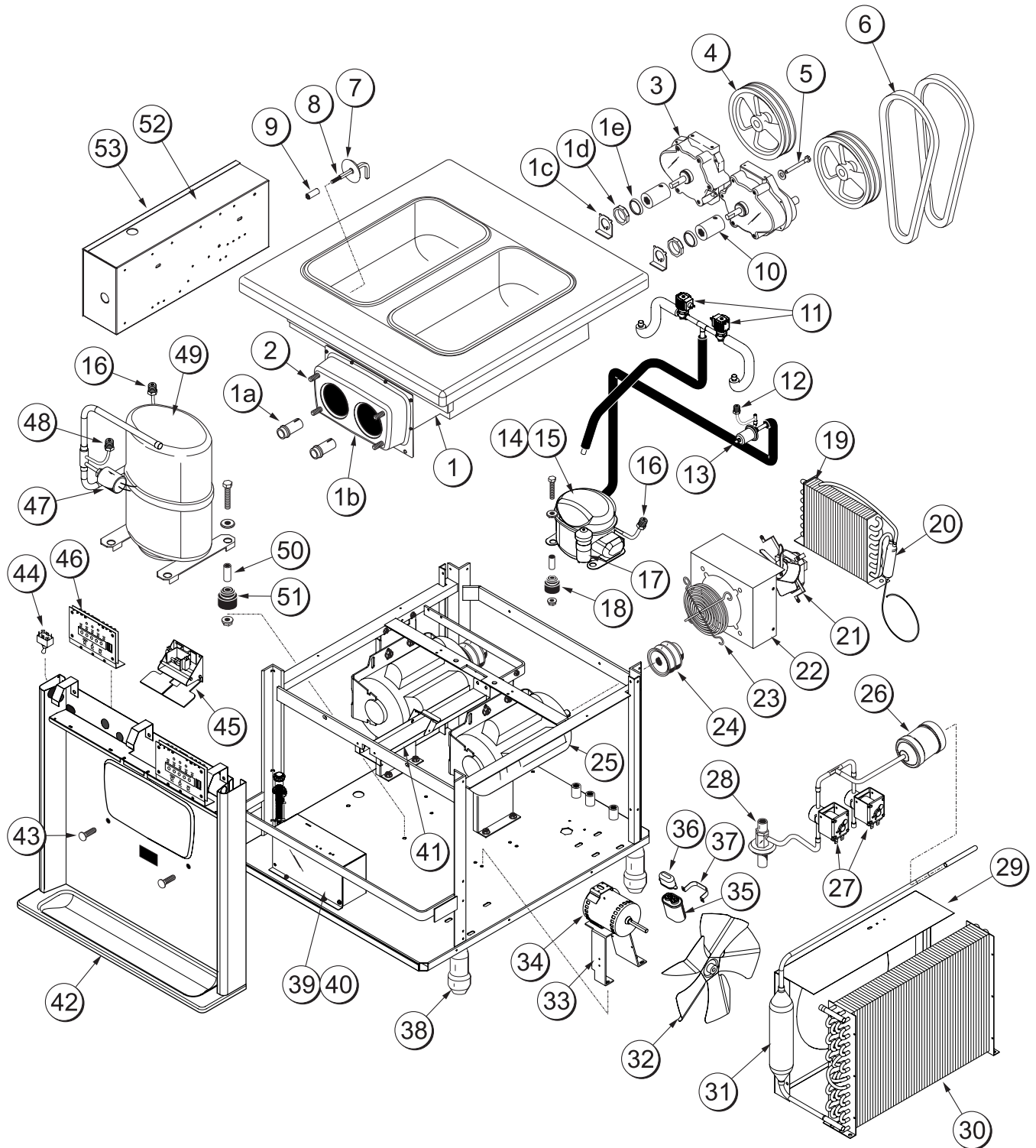

## Model 338 Exploded View

ITEM	DESCRIPTION	PART NO.
1	SHELL A.-INSULATED	X50770
1a	BEARING-REAR SHELL	031324
1b	CONE-NOSE	N/A
1c	WASHER-BEARING-LOCK	012864
1d	NUT-BRASS BEARING	028991
1e	GUIDE-DRIP SEAL	028992
2	STUD-NOSE CONE	022822
3	GEAR A.*REDUCER 4.21:1	021286
4	PULLEY-2AK64-5/8 BORE	039695
5	SCREW-6X3/8 SL HEX W HD	001825
6	BELT-AX35	022848
7	DISC-PROBE *SQ HOLE*	030965
8	PROBE A.-MIX *SQUARE*	X30922
9	SPACER-PROBE *SQ HOLE*	030966
10	COUPLING-DRIVE 3/4 HEX	012721
11	VALVE-SOLENOID 7/16 ORF	048626-
12	VALVE-ACCESS 1/4FL X 3/8	043232
13	VALVE-EPR 1/4S	022665
14	RELAY-START-COMP.	047702-27
15	COMPRESSOR TL3G-R134A	047701-
16	VALVE-ACCESS-1/4 MFLX1/4	047016
17	CAPACITOR-START-60UF	047703
18	KIT-MOUNTING COMP.	047704
19	CONDENSER-AC-7X6X1.25	027155
20	DRYER-CAP. TUBE	047699
21	MOTOR-FAN 105C FM 3000 RPM	027309-27
22	SHROUD-DANFOSS	048818
23	GUARD-FAN	028534-1
24	PULLEY-2AK20 X 5/8 BORE	034238

ITEM	DESCRIPTION	PART NO.
25	MOTOR-1.0 HP	013102-
26	DRYER-FILTER-HP62-3/8	048901
27	VALVE-SOLENOID 7/64ORF	043449-
28	VALVE-EXP-AUTO-1/4S X1/4	046365
29	SHROUD-FAN	044293
30	CONDENSER-AC-19X14X2.5	048623
31	ACCUMULATOR-COPPER 2"	047062
32	FAN-5 BLADE 12" PUSH	047279
33	BRACKET-FAN	048584
34	MOTOR-FAN 80 WATT 1550	051744-
35	CAPACITOR-RUN-4UF-440V	051785
36	BOOT-CAPACITOR INSUL.	031314
37	BRACKET-CAPACITOR	031205
38	LEG-4" SS-W/ORING	013458
39	BOX A.-CAP & RELAY	SEE PG. 78
40	COVER-CAP. RELAY BOX	044530
41	GUIDE A.-DRIP PAN	X51567
42	PANEL A.-FRONT	X51590
43	BOLT-CARRIAGE 1/4-20 X 3/4	012347
44	SWITCH-TOGGLE-4PDT	037394
45	SWITCH A.-DRAW	X38547
46	BOARD-LOGIC-GEN 2.6-SD	X36641SER1
47	SWITCH-PRESSURE 440 PSI	048230
48	VALVE-ACCESS 1/4FL X 1/4	044404
49	COMPRESSOR AHA2490ZXD-AH556E	047519-
50	SLEEVE-MOUNTING-COMP.	039924
51	GROMMET-COMP. MT	039923
52	CONTROL A.	SEE PG. 69
53	COVER-CONTROL BOX	042886

# Model 338 Panel Identification

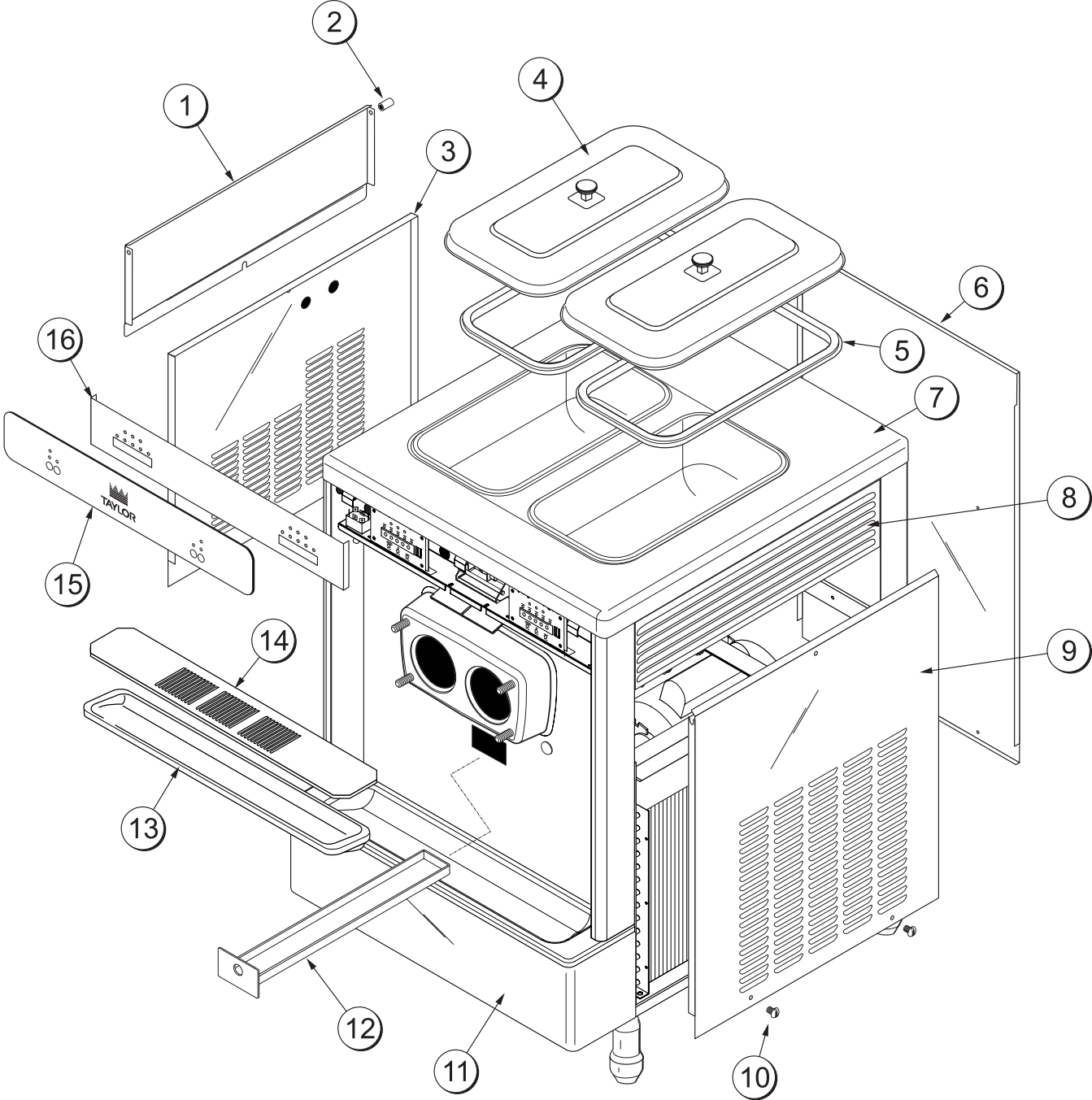

### Model 338 Panel Identification

ITEM	DESCRIPTION	PART NO.
1	PANEL A.-SIDE UPPER RIGHT	X48596
2	BUSHING-PANEL	013289
3	PANEL A.-SIDE *LEFT	X51596
4	COVER A.-HOPPER-STD	X38458-SER
5	GASKET-HOPPER COVER	038474
6	PANEL-REAR	051600
7	HOOD	042866
8	LOUVER-SIDE	017471
9	PANEL-SIDE-RIGHT	048487

ITEM	DESCRIPTION	PART NO.
10	SCREW-1/4-20X3/8 RHM-SS	011694
11	TRIM-FRONT	051595
12	PAN A.-DRIP 15 1/8 LONG	X51601
13	TRAY-DRIP 22-7/8L X 5-1/8W	014533
14	SHIELD-SPLASH 23 L	022766
15	DECAL-DEC-TAYLOR-SS	032919
16	PLATE-DEC-754-755	032961
*17	TRIM-REAR CORNER LEFT	044280
*18	TRIM-REAR CORNER RIGHT	044281

\*NOT SHOWN

# Model 339 Exploded View

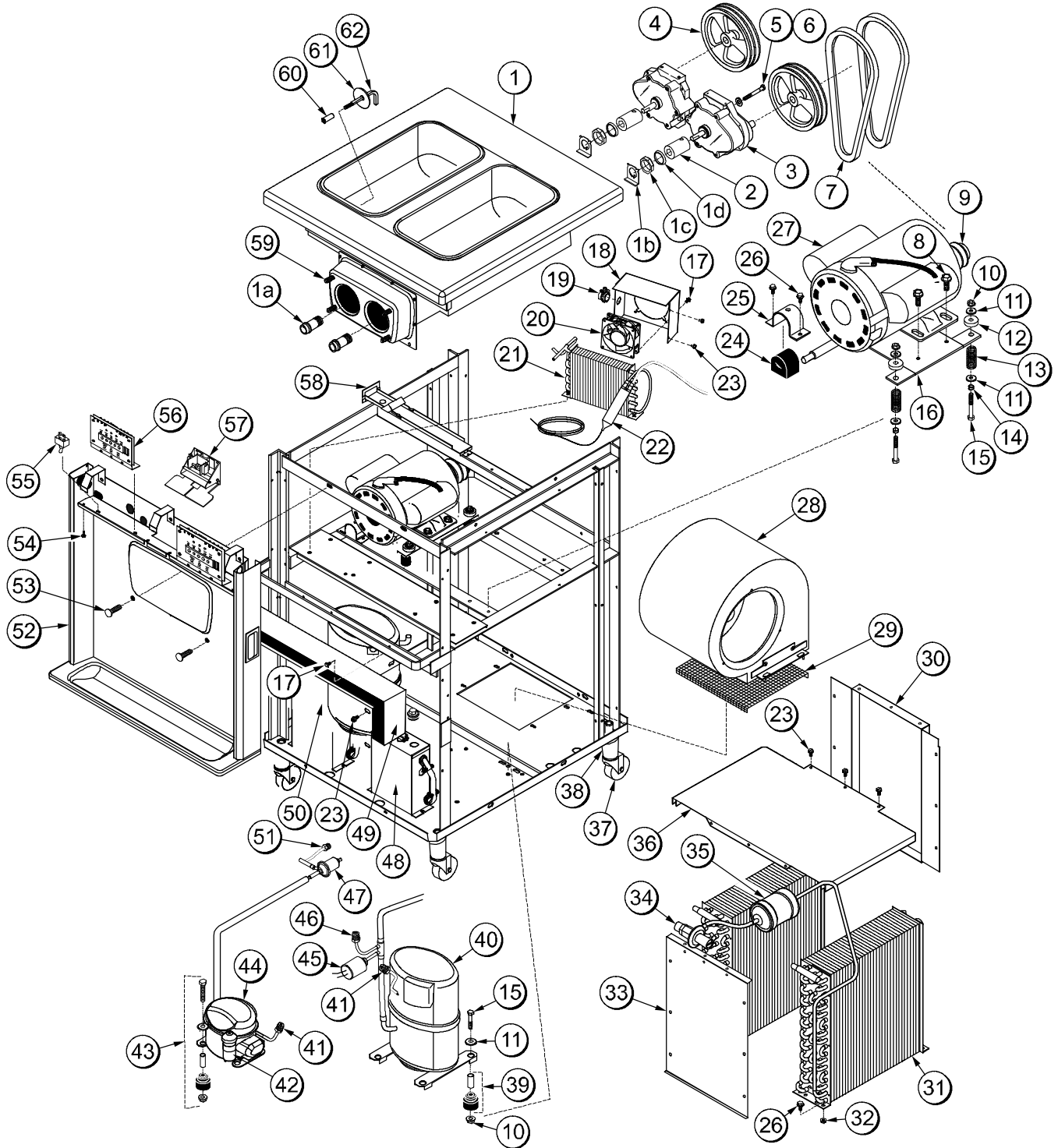

## Model 339 Exploded View

ITEM	DESCRIPTION	PART NO.
1	SHELL A.-INSULATED	X50770
1a	BEARING-REAR SHELL	031324
1b	WASHER-BEARING LOCK	012864
1c	NUT-BRASS BEARING	028991
1d	GUIDE-DRIP SEAL	028992
2	COUPLING-DRIVE 3/4 HEX	012721
3	GEAR A.-REDUCER 4.21:1	021286
4	PULLEY-2AK64-5/8 BORE	039695
5	SCREW-5/16-18 X 3-1/4 STL	022678
6	WASHER-5/16 SAE FLAT CR3	017660
7	BELT-AX33	024396
8	SCREW-5/16-18X7/8 SERR.	034238
9	PULLEY-2AK20 X 5/8 BORE	017973
10	NUT-5/16-18 WHIZ FLANGE	017327
11	WASHER-5/16 USS FLAT CR3	000651
12	GROMMET-7/16 X 5/16	016212
13	SPRING-COMP.970X.115X2.00	025707
14	BUSHING-MTNG RUBBER	012258
15	SCREW-5/16-18X1-3/4 GRD 2	019691
16	HINGE A.-MOTOR	X25731
17	SCREW-10-32X3/8 UNSL HWH	062253-27
18	SHROUD-DANFOSS	039381
19	CONNECTOR-BX 3/8 STR-	027386
20	MOTOR-FAN 105CFM 3000	014569
21	CONDENSER-AC-7X6X1.25	027155
22	DRYER-CAP.TUBE.026IDX13F	X28699
23	SCREW-10X3/8 SLOTTED HEX	047699
24	GROMMET-7/16 X 5/16	015582
25	CLAMP-MOUNTING	016212
26	SCREW-1/4-20X5/8 SERR.	012257
27	MOTOR-1.0 HP	017522
28	BLOWER A.	013102-27
29	FILTER-AIR-18.00L X 13.50H	X53725-27
30	SHROUD-CONDENSER REAR	052779-3

ITEM	DESCRIPTION	PART NO.
31	CONDENSER-AC-12LX18H	046575
32	NUT-1/4-20 WHIZ FLANGE	055813-1
33	SHROUD-CONDENSER FRNT	017523
34	VALVE-EXP-AUTO-1/4S X1/4	046574
35	DRYER-FILTER-HP62-3/8 X 1/4	046365
36	SHROUD-CONDENSER TOP	048901
37	CASTER-SWV 5/8 STEM 4IN WHEEL	046576
38	ADAPTOR A.-CASTER	018794
39	KIT-MTG-COMPRESSOR	X18915
40	COMPRESSOR CS14K6E-PFV-238	052197
41	VALVE-ACCESS-1/4 MFLX1/4	052396-27
42	RELAY-START-COMPRESSOR	047016
43	KIT-MTG-COMPRESSOR	052401-27
44	COMPRESSOR TL3G-R134A	047704
45	SWITCH-PRESSURE 440 PSI	047701-27
46	VALVE-ACCESS 1/4FL X 3/8	052663
47	VALVE-EPR1/4S	043232
48	BOX A.-CAP&RELAY	022665
49	CONTROL A.	X52665-27
50	COVER-CONTROL BOX	X32963-27A
51	VALVE-ACCESS1/4FLX1/4	024440
52	PANEL A.-FRONT	044404
53	BOLT-CARRIAGE 1/4-20 X 3/4	X32956
54	SCREW-6-32X3/8 SLTD BINDR	012347
55	SWITCH-TOGGLE-4PDT	002201
56	BOARD-LOGIC-GEN 2.6-SD	037394
57	SWITCH A.-DRAW SELF CLOS	036641-
58	GUIDE A.-DRIP PAN	X38547
59	STUD-NOSE CONE	022822
60	SPACER-PROBE SQUARE	030966
61	DISC-PROBE SQUARE HOLE	030965
62	PROBE A.-MIX SQUARE	X30922

# Model 339 Panel Identification

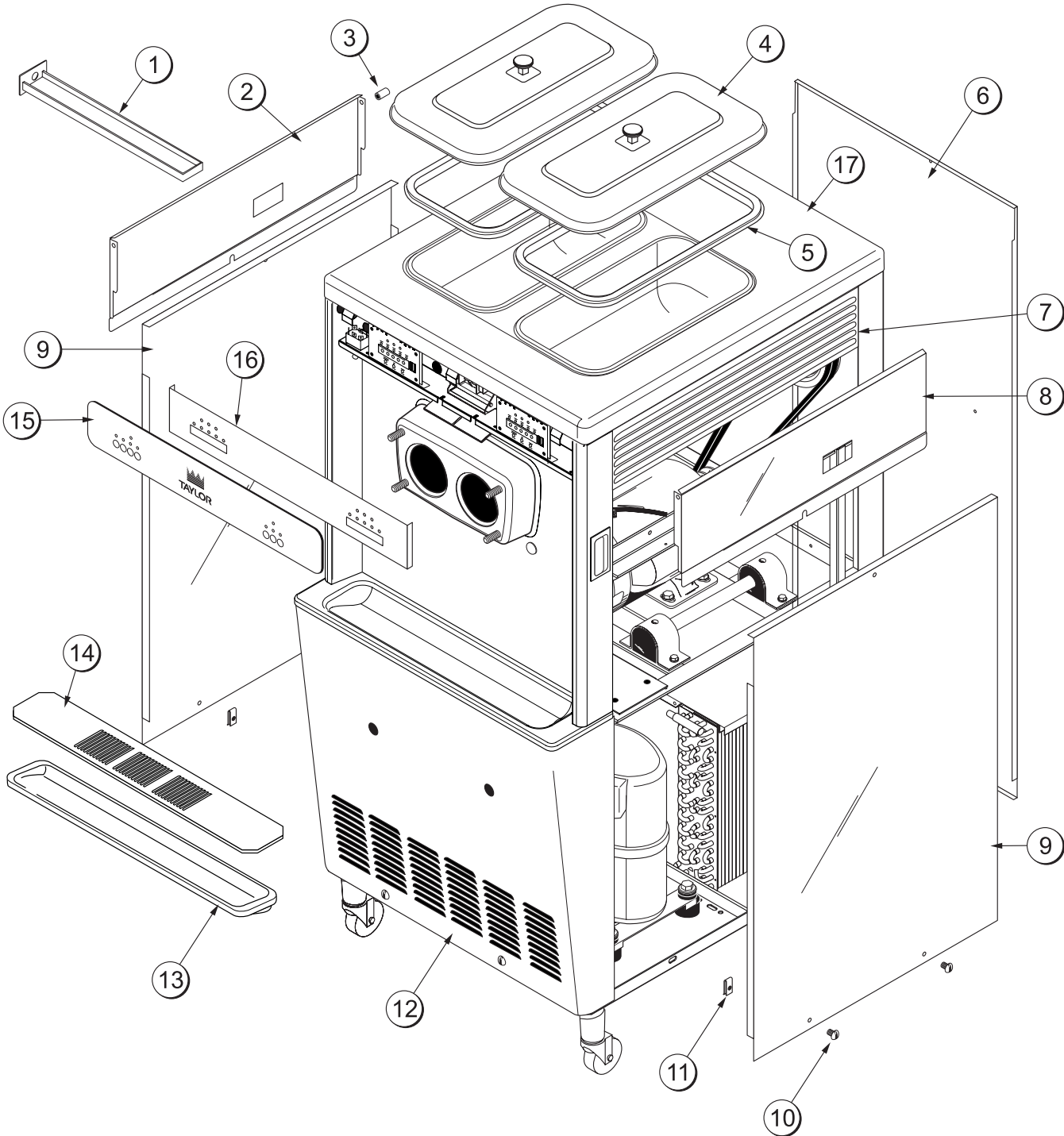



### Model 339 Panel Identification

ITEM	DESCRIPTION	PART NO.
1	PAN-DRIP 17-1/4"LONG	027504
2	PANEL-UPPER SIDE LEFT	028740
3	BUSHING-PANEL	013289
4	COVER A.-HOPPER-STD	X38458-SER
5	GASKET-HOPPER COVER	038474
6	PANEL-REAR	017563
7	LOUVER-SIDE	017471
8	PANEL-UPPER SIDE RIGHT	028741
9	PANEL A.-LOWER SIDE	X24424
10	SCREW-1/4-20X3/8 RHM-SS	011694

ITEM	DESCRIPTION	PART NO.
11	FASTENER-CLIP 1/4-20 U-TYPE	045865
12	PANEL-SERVICE	024439
13	TRAY-DRIP 22-7/8L X 5-1/8W	014533
14	SHIELD-SPLASH 23 L	022766
15	DECAL-DEC-TAYLOR-SS	032919
16	PLATE-DEC	032961
17	HOOD	035434
*18	TRIM-REAR CORNER-RIGHT	013663
*19	TRIM-REAR CORNER-LEFT	013761

\*NOT SHOWN

# Model 750 Exploded View

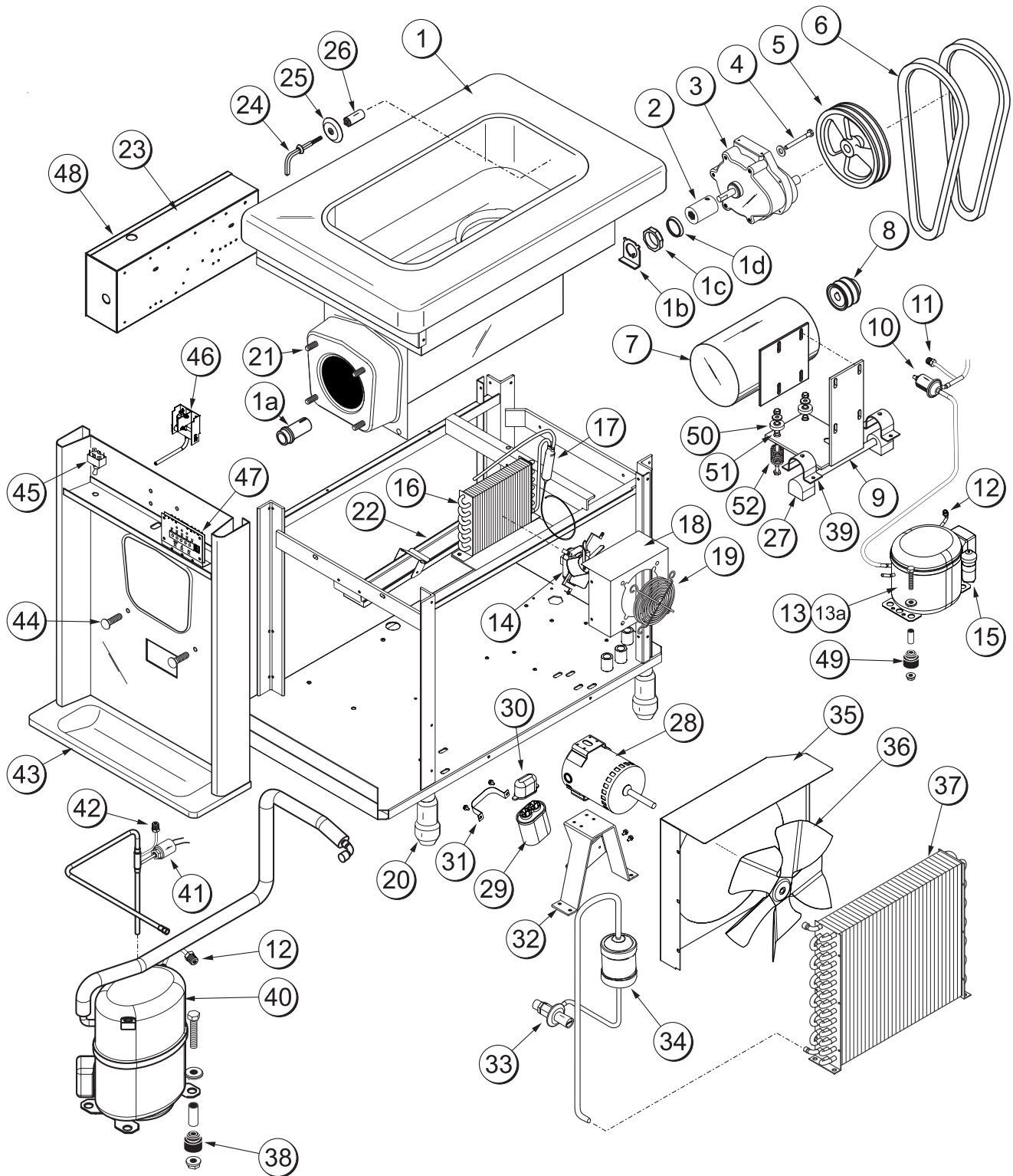

## Model 750 Exploded View

ITEM	DESCRIPTION	PART NO.
1	SHELL A.-INSULATED	X50745
1a	BEARING-REAR SHELL	031324
1b	WASHER-BEARING LOCK	012864
1c	NUT-BRASS BEARING	028991
1d	GUIDE-DRIP SEAL	028992
2	COUPLING-DRIVE 3/4 HEX	012721
3	GEAR A.*REDUCER 4.21:1	021286
4	SCREW-5/16-18X3-1/4 STL	022678
5	PULLEY-2AK74-5/8	027822
6	BELT-AX40	023875
7	MOTOR-1.5 HP	021522-
8	PULLEY-2AK22 X .625-.6265	016403
9	HINGE A.-MOTOR	X25796
10	VALVE-EPR 1/4	022665
11	VALVE-ACCESS 1/4FL X 1/4	044404
12	VALVE-ACCESS-1/4 MFLX1/4	047016
13	COMPRESSOR TL3G-R134A	047701-
13a	RELAY-START-COMPRESSOR	047702-27
14	MOTOR-FAN 105CFM	027309-
15	CAPACITOR-START-60UF	047703
16	CONDENSER-AC-7X6X1.25	027155
17	DRYER-CAP. TUBE .026 ID	047699
18	SHROUD-DANFOSS	027386
19	GUARD-FAN	028534-1
20	LEG-4" SS-W/O-RING	013458
21	STUD-NOSE CONE	022822
22	GUIDE A.-DRIP PAN	X50752
23	CONTROL A.	SEE PG. 72
24	PROBE A.-MIX *SQUARE	X30922

ITEM	DESCRIPTION	PART NO.
25	DISC-PROBE *SQ HOLE	030965
26	SPACER-PROBE *SQ HOLE	030966
27	BUSHING-MT RUBBER	012258
28	MOTOR-FAN 80W	051744-27
29	CAPACITOR-RUN 4UF-440V	051785
30	BOOT-CAPACITOR INSUL.	031314
31	BRACKET-CAPACITOR	031205
32	BRACKET-FAN	038641
33	VALVE-EXP-AUTO-1/4S X 1/4	046365
34	DRYER-FILTER-HP62-3/8 X 1/4	048901
35	SHROUD-FAN	050738
36	FAN-5 BLADE 12" PUSH 32°	047279
37	CONDENSER-AC-15LX14H	046558
38	KIT-MTG.-COMPRESSOR	052196
39	CLAMP-MOUNTING	012257
40	COMPRESSOR RS80C1E-CAV	051858-
41	SWITCH-PRESSURE 405 PSI	052663
42	LINE A.-ACCESS	X42513
43	PANEL A.-FRONT	X50754
44	BOLT-CARRIAGE 1/4-20 X 3/4	012347
45	SWITCH-TOGGLE-DPDT	024295
46	SWITCH A.-DRAW	X33322-SP
47	BOARD-LOGIC-GEN 2.6-SD	X36641SER1
48	COVER-CONTROL BOX	050756
49	KIT-MOUNTING COMP.	047704
50	GROMMET-7/16X5/16	016212
51	CAP-RUBBER MOUNT	011844
52	SPRING-COMP .970x.115x2.0	025707

# Model 750 Panel Identification

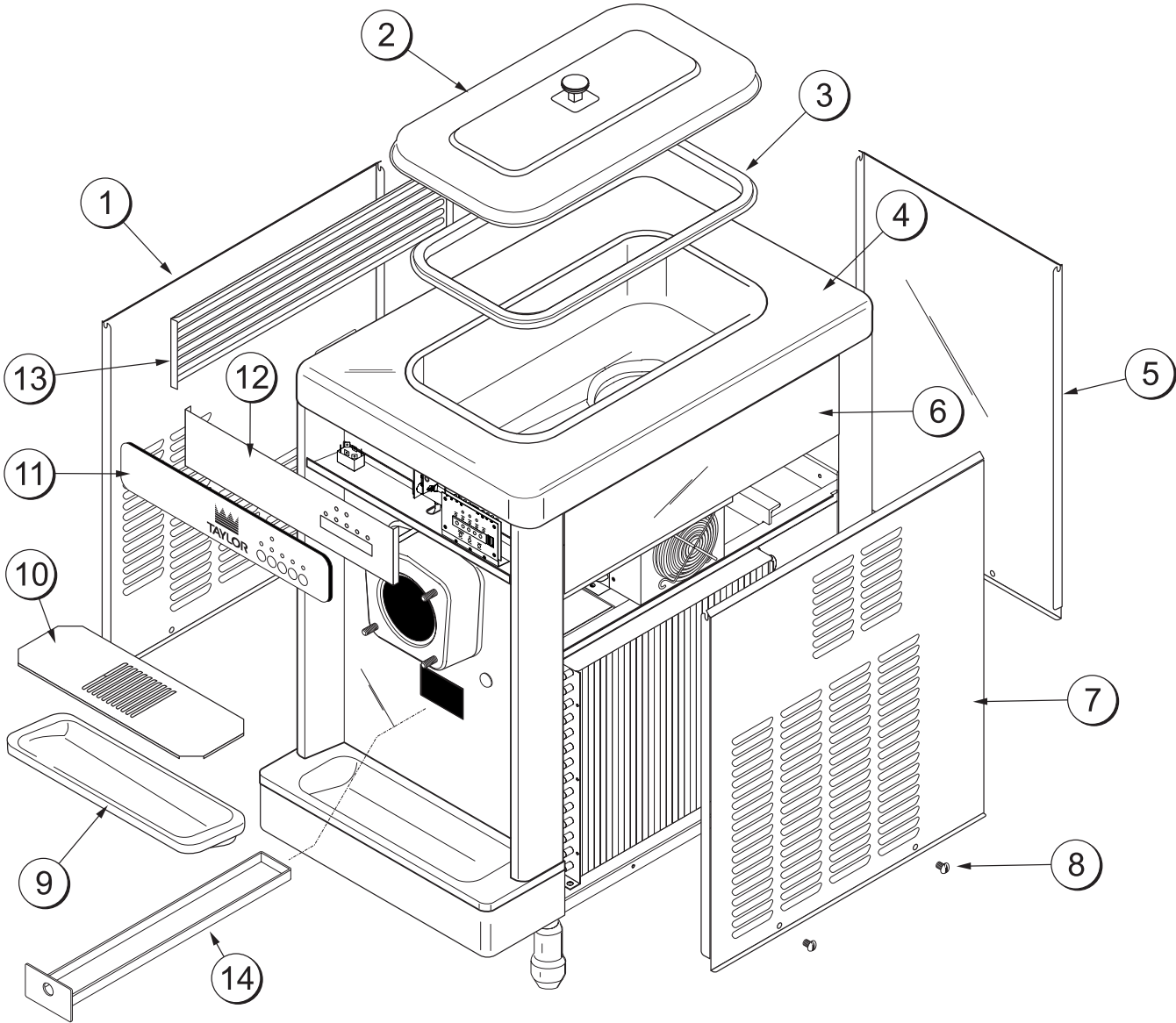

### Model 750 Panel Identification

ITEM	DESCRIPTION	PART NO.
1	PANEL-SIDE LEFT	050741
2	COVER A.-HOPPER-STD	X38458-SER
3	GASKET-HOPPER COVER	038375
4	HOOD A.	X35565
5	PANEL-REAR	020891
6	PANEL-SIDE UPPER RIGHT	042317
7	PANEL-RIGHT	050742
8	SCREW	011694

ITEM	DESCRIPTION	PART NO.
9	TRAY-DRIP 14-7/8L X 5-1/8 SG	013690
10	SHIELD-SPLASH 15"L	022763
11	DECAL-DEC-TAYLOR-SGL-SS	033230
12	PLATE-DEC	033239
13	LOUVER-SIDE	013631
14	PAN-DRIP	050766
*15	TRIM-REAR CORNER-RIGHT	020677
*16	TRIM-REAR CORNER-LEFT	020678

\*NOT SHOWN

# Model 751 Exploded View

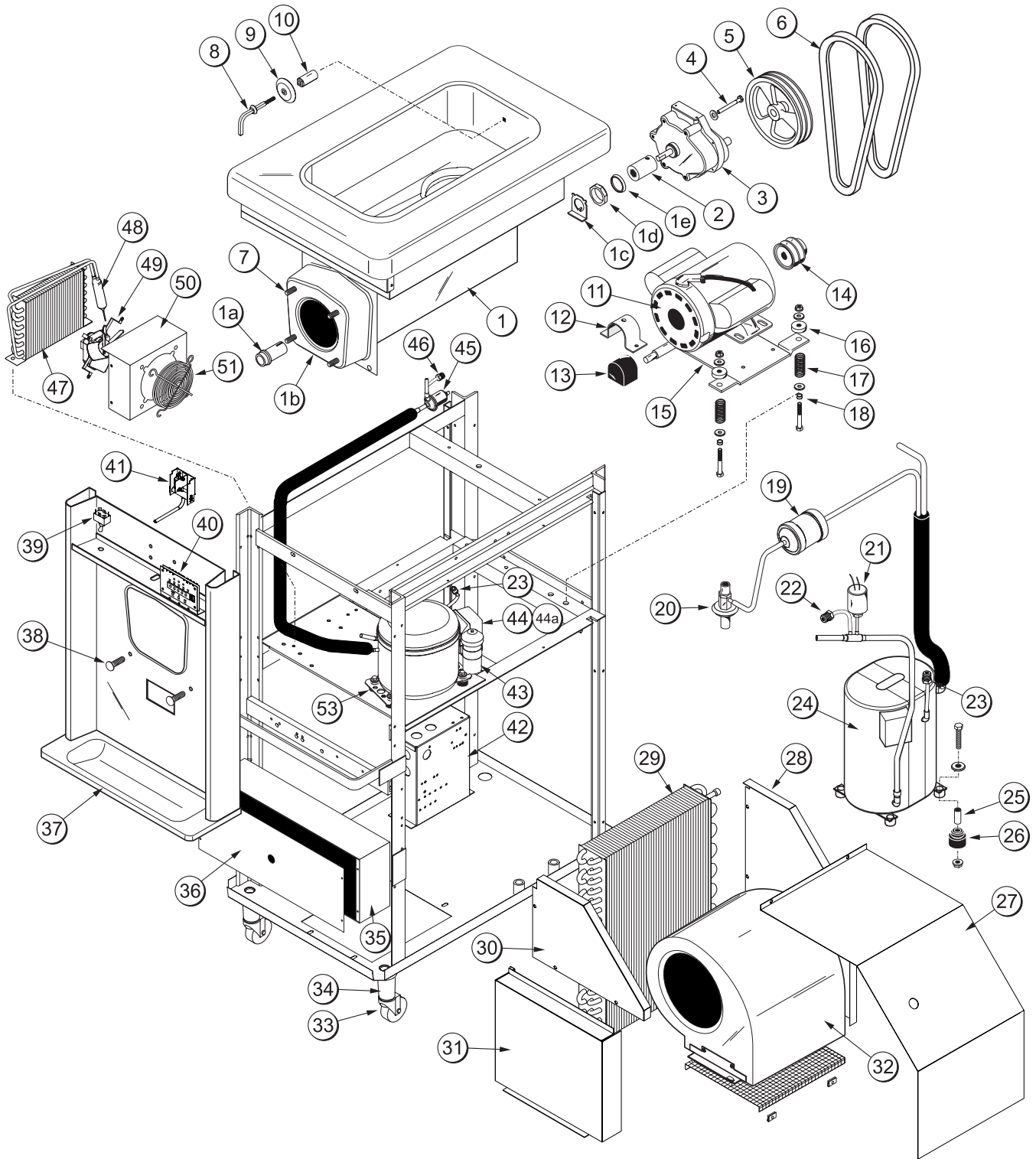

## Model 751 Exploded View

ITEM	DESCRIPTION	PART NO.
1	SHELL A.-INSULATED	X49785
1a	BEARING-REAR SHELL	031324
1b	CONE-NOSE	N/A
1c	WASHER-BEARING LOCK	012864
1d	NUT-BRASS BEARING	028991
1e	GUIDE-DRIP SEAL	028992
2	COUPLING-DRIVE 3/4 HEX	012721
3	GEAR A.*REDUCER 4.21:1	021286
4	SCREW-6X3/8 SL HEX W HD	001825
5	PULLEY-2AK74-5/8	027822
6	BELT-AX35	022848
7	STUD-NOSE CONE	022822
8	PROBE A.-MIX SQUARE	X30922
9	DISC-PROBE *SQ HOLE*	030965
10	SPACER-PROBE *SQ HOLE*	030966
11	MOTOR-1.5 HP	021522-
12	CLAMP-MOUNTING	012257
13	BUSHING-MOUNTING RUBBER	012258
14	PULLEY-2AK22 X .625-.6265	016403
15	HINGE A.-MOTOR	X25731
16	GROMMET-7/16 X 5/16	016212
17	SPRING-COMP.970X.115X2.00	025707
18	CAP-RUBBER MOUNT	011844
19	DRYER-FILTER-HP62-3/8	048901
20	VALVE-EXP-AUTO-1/4 S X 1/4	046365
21	SWITCH-PRESSURE 440 PSI	048230
22	VALVE-ACCESS 1/4FL X 3/8	043232
23	VALVE-ACCESS-1/4 MFL X 1/4	047016
24	COMPRESSOR L63A113BBCA	048259-

ITEM	DESCRIPTION	PART NO.
25	SLEEVE-COMP. MOUNTING	037429
26	GROMMET-COMP. MT	037428
27	SHROUD-CONDENSER SIDE	047167
28	SHROUD-CONDENSER REAR	047166
29	CONDENSER-AC-12LX18H	048233
30	SHROUD-CONDENSER *TOP*	047165
31	SHROUD-CONDENSER	047164
32	BLOWER A.	X53725-27
33	CASTER-SWV 5/8 STEM	018794
34	ADAPTOR A.-CASTER	X18915
35	CONTROL A. AC	SEE PG. 73
36	COVER-CONTROL BOX	033253
37	PANEL A.-FRONT	X33237
38	BOLT-CARRIAGE 1/4-20 X 3/4	012347
39	SWITCH-TOGGLE-DPDT	024295
40	BOARD-LOGIC-GEN 2.6-SD	X36641SER1
41	SWITCH A.-DRAW	X33322-
42	BOX A.-CAP&RELAY	SEE PG. 80
43	CAPACITOR-START-60UF	047703
44	COMPRESSOR TL3G-R134A	047701-
44a	RELAY-START COMPRESSOR	047702-27
45	VALVE-EPR 1/4S	022665
46	VALVE-ACCESS 1/4FL X 1/4	044404
47	CONDENSER	027155
48	DRYER-CAP. TUBE	047699
49	MOTOR-FAN 105CFM 3000	027309-27
50	SHROUD-DANFOSS	027386
51	GUARD-FAN	028534-1
52*	GUIDE A.-DRIP PAN	X28863
53	KIT-MOUNTING DANFOSS	047704

\*NOT SHOWN

# Model 751 Panel Identification

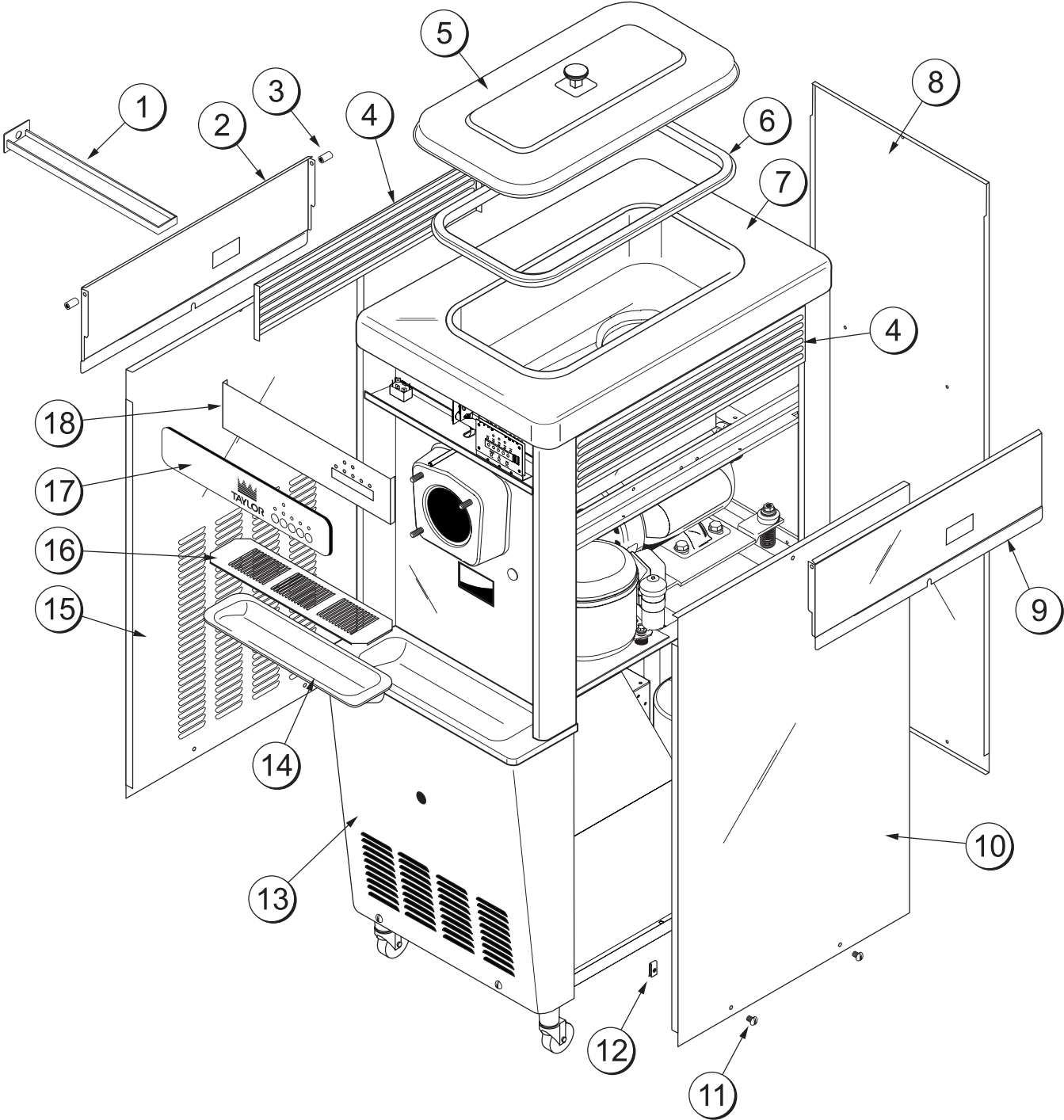



### Model 751 Panel Identification

ITEM	DESCRIPTION	PART NO.
1	PAN-DRIP 11-5/8 LONG	027503
2	PANEL-UPPER SIDE	024426
3	BUSHING-PANEL	013289
4	LOUVER-SIDE	017471
5	COVER A.-HOPPER-STD	X38458-SER
6	GASKET-HOPPER COVER	038375
7	HOOD A.	X35565
8	PANEL-REAR	013637
9	PANEL-UPPER SIDE R.	028823
10	PANEL A.-LOWER SIDE	X24424

ITEM	DESCRIPTION	PART NO.
11	SCREW-1/4-20X3/8 RHM SS	011694
12	FASTENER-CLIP 1/4-20	045865
13	PANEL-SERVICE	047170
14	TRAY-DRIP 14-7/8L X 5-1/8 SG	013690
15	PANEL A.-SIDE-LOWER-LOUV.	X39075
16	SHIELD-SPLASH 15"L	022763
17	DECAL-DEC-TAYLOR-SGL-SS	033230
18	PLATE-DEC	033239
*19	TRIM-REAR CORNER-RIGHT	020883
*20	TRIM-REAR CORNER-LEFT	020882

\*NOT SHOWN

# Model 754 Exploded View

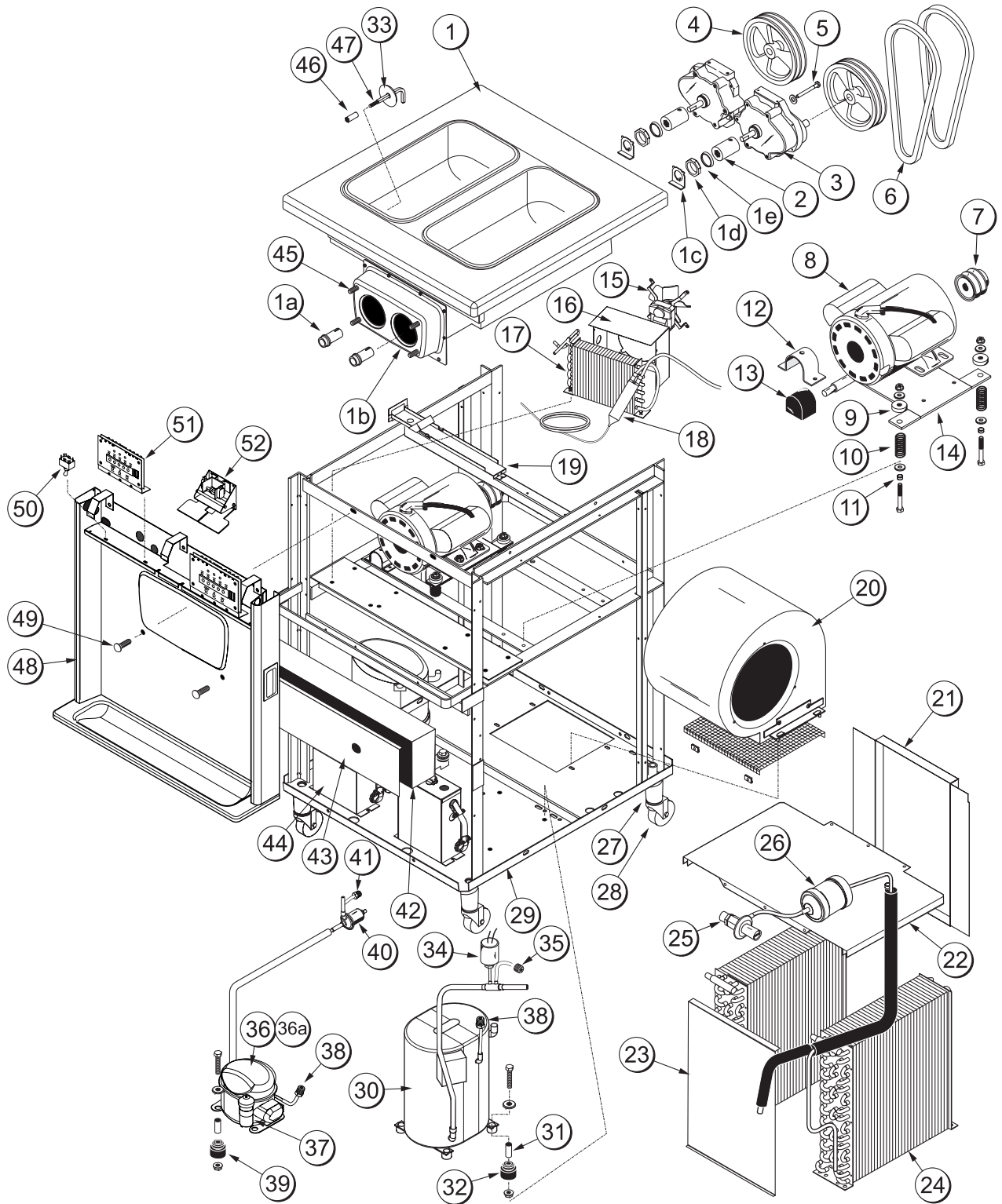

## Model 754 Exploded View

ITEM	DESCRIPTION	PART NO.
1	SHELL A.-INSULATED	X50327
1a	BEARING-REAR SHELL	031324
1b	CONE-NOSE	N/A
1c	WASHER-BEARING LOCK	012864
1d	NUT-BRASS BEARING	028991
1e	GUIDE-DRIP SEAL	028992
2	COUPLING-DRIVE 3/4 HEX	012721
3	GEAR A.*REDUCER 4.21:1	021286
4	PULLEY-2AK74-5/8	027822
5	SCREW-6X3/8 SL HEX W HD	001825
6	BELT-AX35	022848
7	PULLEY-2AK22 X .625-.6265	016403
8	MOTOR-1.5 HP	021522
9	GROMMET-7/16X5/16	016212
10	SPRING-COMP .970 X .115	025707
11	CAP-RUBBER MOUNT	011844
12	CLAMP-MOUNTING	012257
13	BUSHING-MOUNTING	012258
14	HINGE A.-MOTOR	X27531
15	MOTOR-FAN 105CFM	027309-27
16	SHROUD-DANFOSS	027386
17	CONDENSER AC-7X6X1.25	027155
18	DRYER-CAP. TUBE	047699
19	GUIDE A.-DRIP PAN	X28699
20	BLOWER A.	X53478-
21	SHROUD-COND *REAR	046575
22	SHROUD-COND TOP	046576
23	SHROUD-COND *AC*FRONT	046574
24	CONDENSER-AC-12 LX18 H	048233

ITEM	DESCRIPTION	PART NO.
25	VALVE-EXP-AUTO-1/4S X 1/4	046365
26	DRYER-FILTER-HP62	048901
27	ADAPTOR A.-CASTER	X18915
28	CASTER-SWV 5/8 STEM	018794
29	FRAME A.	N/A
30	COMPRESOR-L63A113BBCA	048259-
31	SLEEVE-COMP. MOUNTING	037429
32	GROMMET-COMPRESSOR	037428
33	DISC-PROBE	030965
34	SWITCH-PRESSURE 440 PSI	048230
35	VALVE-ACCESS 1/4FL X 1/4	044404
36	COMPRESSOR-TL3G-R134A	047701-
36a	RELAY	047702-27
37	CAPACITOR-START-60MF	047703
38	VALVE-ACCESS-1/4 MFL	047016
39	KIT-COMPRESSOR MT	047704
40	VALVE-EPR 1/4S	022665
41	VALVE-ACCESS 1/4FL X 3/8S	044455
42	CONTROL A.	SEE PG. 70
43	COVER-CONTROL BOX	024440
44	BOX A.-CAP&RELAY	SEE PG. 81
45	STUD-NOSE CONE	022822
46	SPACER-PROBE	030966
47	PROBE A.-MIX *SQUARE*	X30922
48	PANEL A.-FRONT	X32956
49	BOLT-CARRIAGE 1/4-20 X 3/4	012347
50	SWITCH-TOGGLE-4PDT	037394
51	BOARD-LOGIC	X36641SER1
52	SWITCH A.-DRAW	X38547

# Model 754 Panel Identification

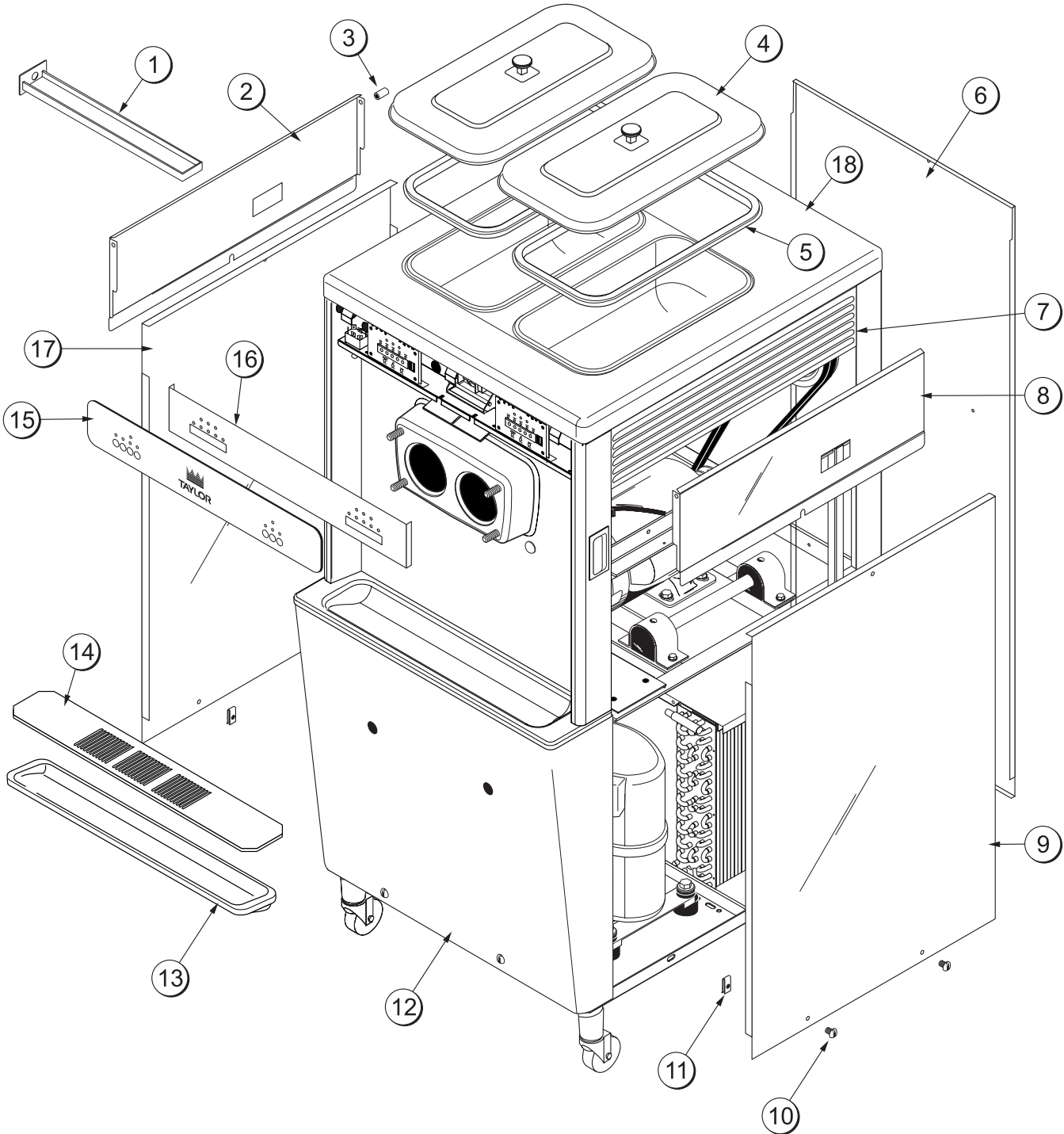

### Model 754 Panel Identification

ITEM	DESCRIPTION	PART NO.
1	PAN-DRIP 17-1/4"LONG	027504
2	PANEL-UPPER SIDE LEFT	028822
3	BUSHING-PANEL	013289
4	COVER A. - HOOPER - STD	X38458-SER
5	GASKET-HOPPER COVER	038474
6	PANEL-REAR	017563
7	LOUVER-SIDE	017471
8	PANEL-UPPER SIDE RIGHT	028823
9	PANEL A.-SIDE LOWER RIGHT	X46448
10	SCREW-1/4-20X3/8 RHM-SS	011694

ITEM	DESCRIPTION	PART NO.
11	FASTENER-CLIP 1/4-20 U-TYP	045865
12	PANEL-SERVICE	046584
13	TRAY-DRIP 22-7/8L X 5-1/8W	014533
14	SHIELD-SPLASH 23 LONG	022766
15	DECAL-DEC-TAYLOR-SS	032919
16	PLATE-DEC-754-755	032961
17	PANEL A.-SIDE LOWER LEFT	X46447
18	HOOD	035434
*19	TRIM-REAR CORNER-RIGHT	013663
*20	TRIM-REAR CORNER-LEFT	013761

\*NOT SHOWN

# Model 774 Exploded View

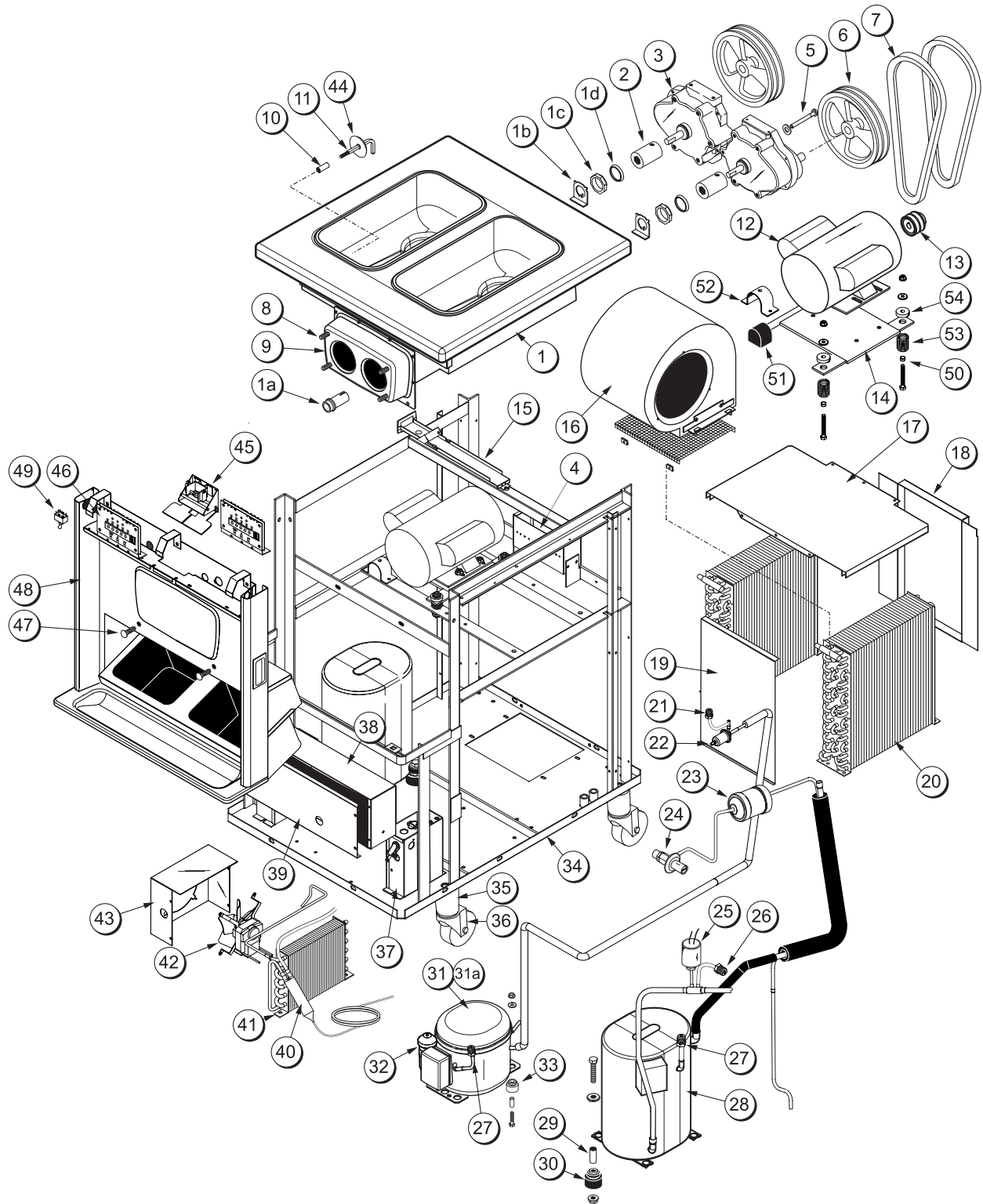

## Model 774 Exploded View

ITEM	DESCRIPTION	PART NO.
1	SHELL A.-INSULATED	X50327
1a	BEARING-REAR SHELL	031324
1b	WASHER-BEARING LOCK	012864
1c	NUT-BRASS BEARING	028991
1d	GUIDE-DRIP SEAL	028992
2	COUPLING-DRIVE 3/4 HEX	012721
3	GEAR A. REDUCER 4.21:1	021286
4	BOX-SPLICE	N/A
4a	BLOCK-TERMINAL 2P-L1,L2	039422
4b	LUG-GROUNDING	020928
4c	COVER-SPLICE BOX	042069
5	SCREW-5/16-18 X 3 HEX CAP	009497
6	PULLEY-2AK74-5/8	027822
7	BELT-AX34	025729
8	STUD-NOSE CONE	022822
9	CONE-NOSE	N/A
10	SPACER-PROBE *SQ HOLE*	030966
11	PROBE A.-MIX *SQUARE*	X30922
12	MOTOR-1.5 HP	021522-
13	PULLEY-2AK22 X .625-.6265	016403
14	HINGE A.-MOTOR	X25703
15	GUIDE A.-DRIP PAN	X28699
16	BLOWER A.	X53478-27
17	SHROUD-COND *AC*TOP	046576
18	SHROUD-COND *AC*REAR	046575
19	SHROUD-COND *AC*FRONT	046574
20	CONDENSER-AC-12LX18H	048233
21	VALVE-ACCESS 1/4FL X 1/4	044404
22	VALVE-EPR 1/4S	022665
23	DRYER-FILTER-HP62-3/8	048901
24	VALVE-EXP-AUTO-1/4 S X 1/4	046365

ITEM	DESCRIPTION	PART NO.
25	SWITCH-PRESSURE 440 PSI	048230
26	VALVE-ACCESS 1/4FL X 3/8	043232
27	VALVE-ACCESS 1/4FL X 1/4	047016
28	COMPRESSOR L63A113BBCA	048259-27
29	SLEEVE-COMP. MOUNTING	037429
30	GROMMET-COMP. MT	037428
31	COMPRESSOR-TL3G-R134A	047701-
31a	RELAY-START COMP.	047702-
32	CAPACITOR-START-60UF	047703
33	KIT COMPRESSOR MOUNT	047704
34	FRAME A. AC	N/A
35	ADAPTOR A.-CASTER	X18915
36	CASTER-SWV 5/8 STEM	018794
37	BOX A.-CAP&RELAY	SEE PG. 82
38	CONTROL A. AC	SEE PG. 74
39	COVER-CONTROL BOX	024440
40	DRYER-CAP TUBE	047699
41	CONDENSER-AC-7X6X1.25	027155
42	MOTOR-FAN 105CFM	027309-27
43	SHROUD-DANFOSS	027386
44	DISC-PROBE *SQ HOLE*	030965
45	SWITCH A.-DRAW	X38547
46	BOARD-LOGIC-GEN 2.6-SD	X36641SER1
47	BOLT-CARRIAGE 1/4-20 X 3/4	012347
48	PANEL A.-FRONT-SYRUP	X42539
49	SWITCH-TOGGLE-4PDT	037394
50	CAP-RUBBER MOUNT	011844
51	BUSHING-MOUNTING	012258
52	CLAMP-MOUNTING	012257
53	SPRING-COMP.970x.115x2.0	025707
54	GROMMET-7/16 X 5/16	016212

# Model 774 Panel Identification

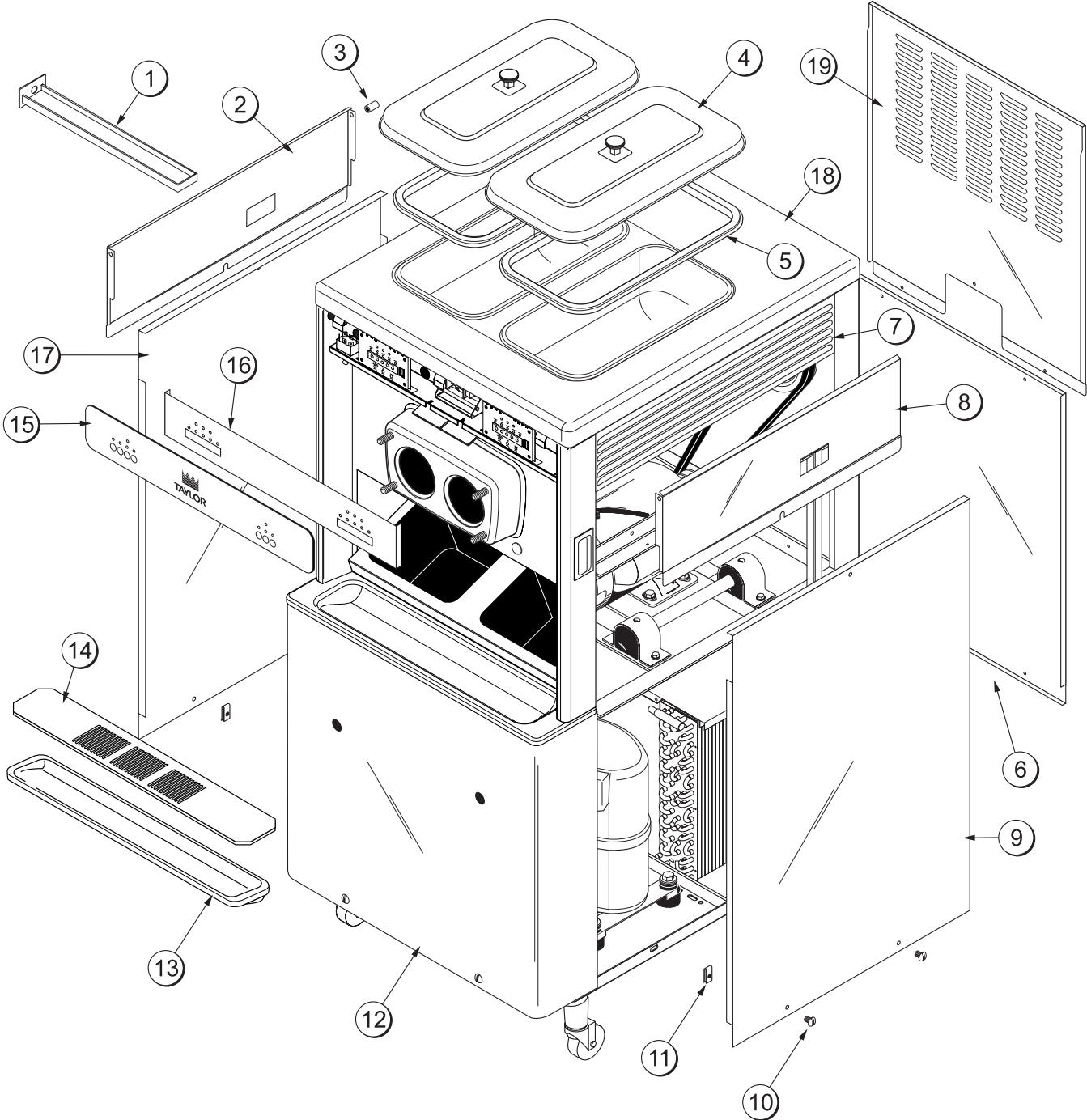



### Model 774 Panel Identification

ITEM	DESCRIPTION	PART NO.
1	PAN-DRIP 17-1/4"LONG	027504
2	PANEL-UPPER SIDE L.	028822
3	BUSHING-PANEL	013289
4	COVER A.-HOPPER-STD	X38458-SER
5	GASKET-HOPPER COVER	038474
6	PANEL-LOWER REAR	042577
7	LOUVER-SIDE	017471
8	PANEL-UPPER SIDE R.	028823
9	PANEL A.-SIDE LOWER R.	X46448
10	SCREW-1/4-20X3/8 RHM-SS	011694

ITEM	DESCRIPTION	PART NO.
11	FASTENER-CLIP 1/4-20	045865
12	PANEL-SERVICE	047077
13	TRAY-DRIP 22-7/8L X 5-1/8W	014533
14	SHIELD-SPLASH 23 L	022766
15	DECAL-DEC-TAYLOR-SS	032919
16	PLATE-DEC-754-755	032961
17	PANEL A.-SIDE LOWER LEFT	X46447
18	HOOD	035434
19	PANEL A.-UPPER REAR	X42574
*20	TRIM-REAR CORNER-RIGHT	013663
*21	TRIM-REAR CORNER-LEFT	013761

\*NOT SHOWN

# Rail A.-Syrup X42541

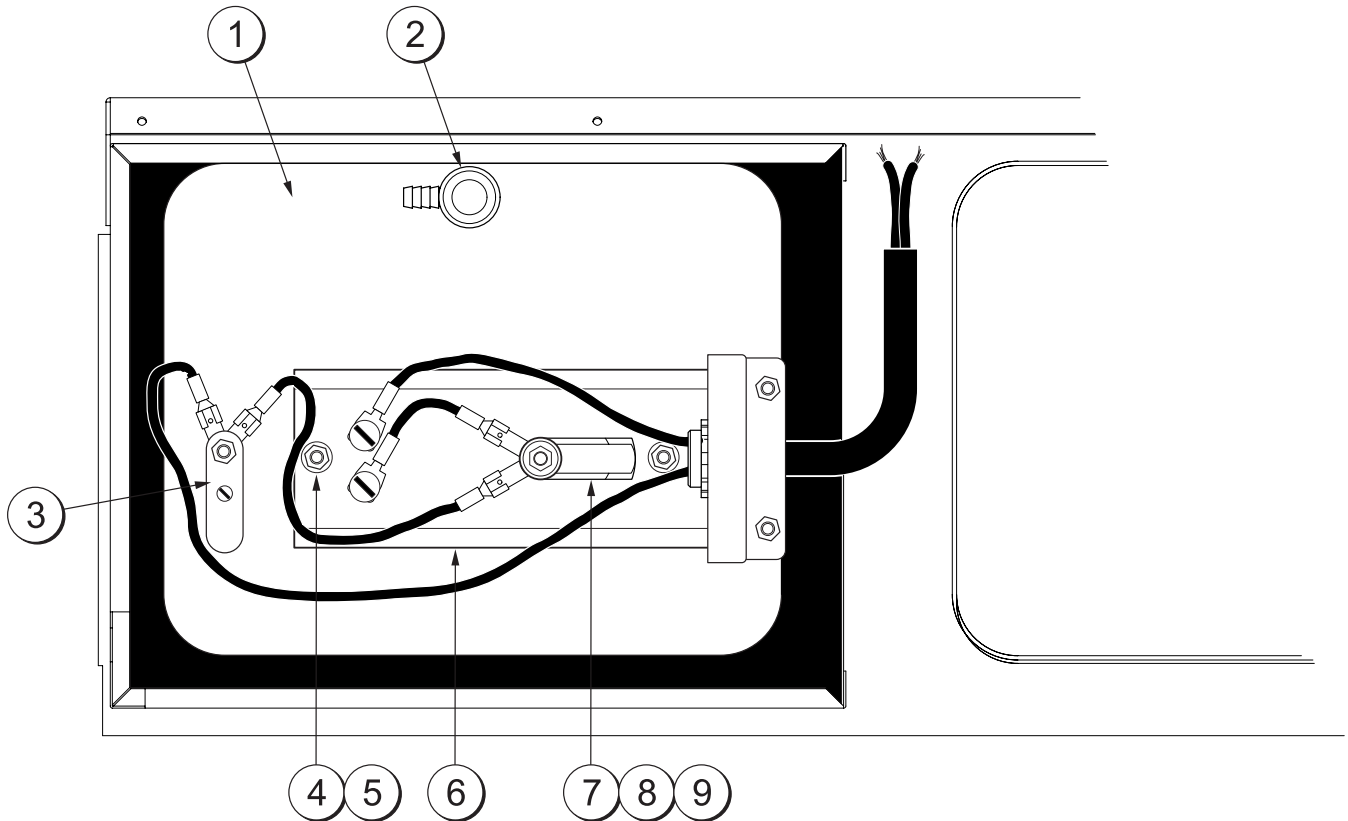

ITEM	DESCRIPTION	PART NO.
1	COVER A.-TANK	X42545
2	PLUG-DRAIN-WYOTT	023953-5
3	THERMOSTAT-ADJ-SNAP	049993
4	WASHER-3/16 FLAT STEEL	005194
5	NUT-10-32 HEX	005598

ITEM	DESCRIPTION	PART NO.
6	HEATER-STRIP-350W-240V	023953-4
7	THERMOSTAT-HI LIMIT-SNAP	049992
8	WASHER-#8 LOCK	007543
9	NUT-8-32 HEX	000969

*Notes:*

---

---

---

---

---

---

---

---

---

---

---

---

---

---

---

---

---

---

---

---

---

---

---

---

---

---

# Model 794 Exploded View

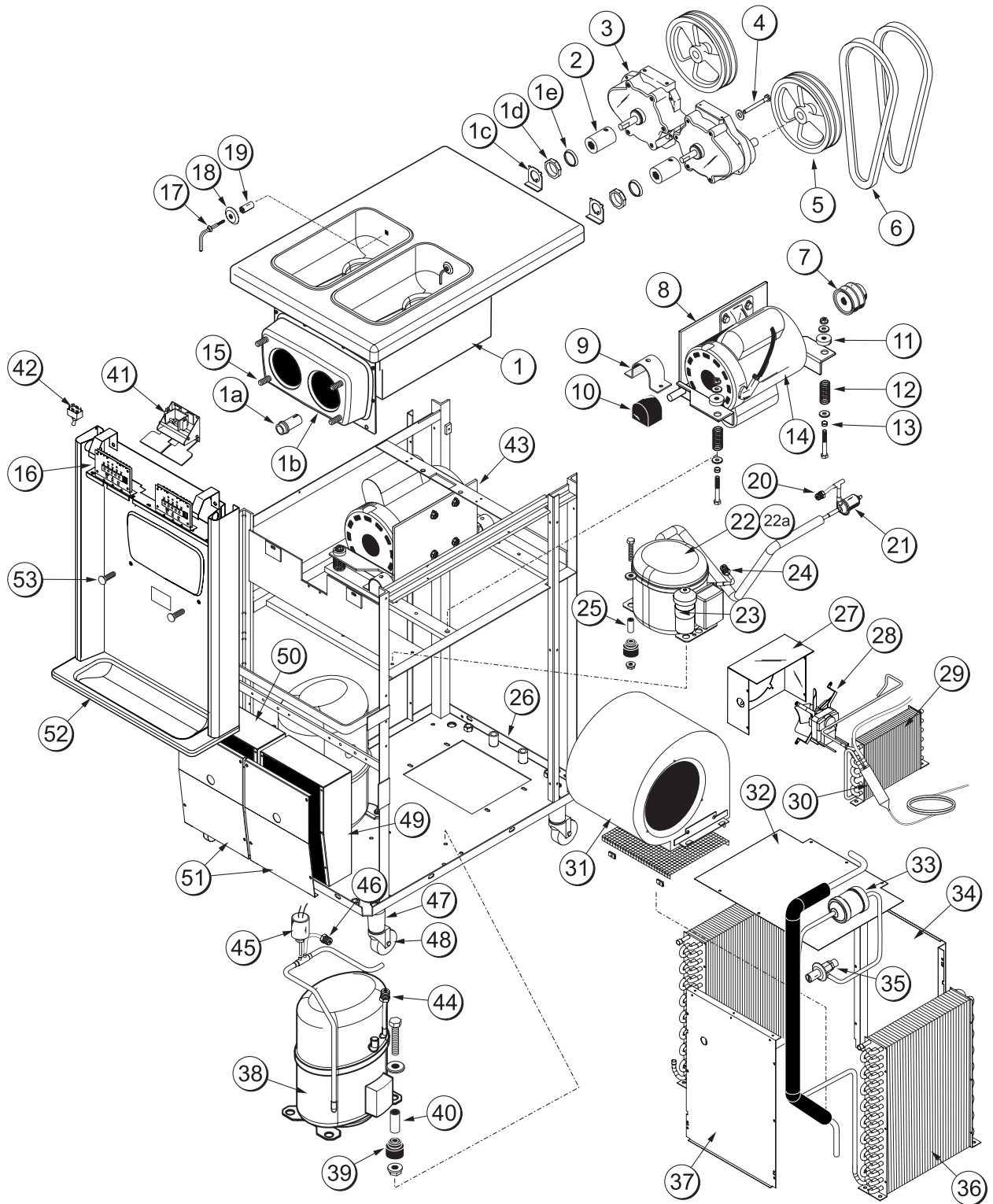

## Model 794 Exploded View

ITEM	DESCRIPTION	PART NO.
1	SHELL A.-INSULATED	X51711
1a	BEARING-REAR SHELL	031324
1b	CONE-NOSE	N/A
1c	WASHER-BEARING LOCK	012864
1d	NUT-BRASS BEARING	028991
1e	GUIDE-DRIP SEAL	028992
2	COUPLING-DRIVE 3/4 HEX	012721
3	GEAR A.*REDUCER 4.21:1	021286
4	SCREW-5/16-18 X 3 HEX CAP	009497
5	PULLEY-2AK74-5/8	027822
6	BELT-AX31	041575
7	PULLEY-2AK22 X.625-.6265	016403
8	HINGE A.-MOTOR-RIGHT	X41836
9	CLAMP-MOUNTING	012257
10	BUSHING-MT RUBBER	012258
11	GROMMET-7/16 X 5-16	016212
12	SPRING-COMP.970x.115x2.0	025707
13	CAP-RUBBER MOUNT	011844
14	MOTOR-1.5 HP	021522-
15	STUD-NOSE CONE	022822
16	BOARD-LOGIC-GEN 2.6-SD	X36641SER1
17	PROBE A.-MIX	X30922
18	DISC-PROBE *SQ HOLE*	030965
19	SPACER-PROBE *SQ HOLE*	030966
20	VALVE-ACCESS 1/4FL X 1/4	044404
21	VALVE-EPR 1/4S	022665
22	COMPRESSOR-TL3G-R134A	047701-
22a	RELAY-START COMP.	047702-27
23	CAPACITOR-START-60UF	047703
24	VALVE-ACCESS-1/4MFL X 1/4	047016
25	KIT-MOUNTING-COMP.	047704

ITEM	DESCRIPTION	PART NO.
26	FRAME A.	N/A
27	SHROUD-DANFOSS	027386
28	MOTOR-FAN 105CFM	027309-27
29	CONDENSER-AC-7X6X1.25	027155
30	DRYER-CAP. TUBE	047699
31	BLOWER A.	X53478-27
32	SHROUD-CONDENSER TOP	048245
33	DRYER-FILTER-HP62	048901
34	SHROUD-REAR	042693
35	VALVE-EXP-AUTO-1/4S	046365
36	CONDENSER-AC-12Lx18H	048233
37	SHROUD-FRONT	042692
38	COMPRESSOR AHA2490ZXD-AH556E	047519-
39	GROMMET-COMP. MT	039923
40	SLEEVE-MOUNTING-COMP.	039924
41	SWITCH A.-DRAW	X38547
42	SWITCH-TOGGLE-4PDT	037394
43	HINGE A.-MOTOR-LEFT	X41830
44	VALVE-ACCESS-1/4FL X 1/4	047016
45	SWITCH-PRESSURE 440PSI	048230
46	VALVE-ACCESS-1/4FL X 3/8	043232
47	ADAPTOR A.-CASTER	X18915
48	CASTER-SWV 5/8 STEM	018794
49	CONTROL A. RIGHT	SEE PG. 76
50	CONTROL A. LEFT	SEE PG. 75
51	COVER-CONTROL BOX	048336
52	PANEL A.-FRONT	X41820
53	BOLT-CARRIAGE 1/4-20	012347
*54	GUIDE A.-DRIP PAN	X45691

\*NOT SHOWN

# Model 794 Panel Identification

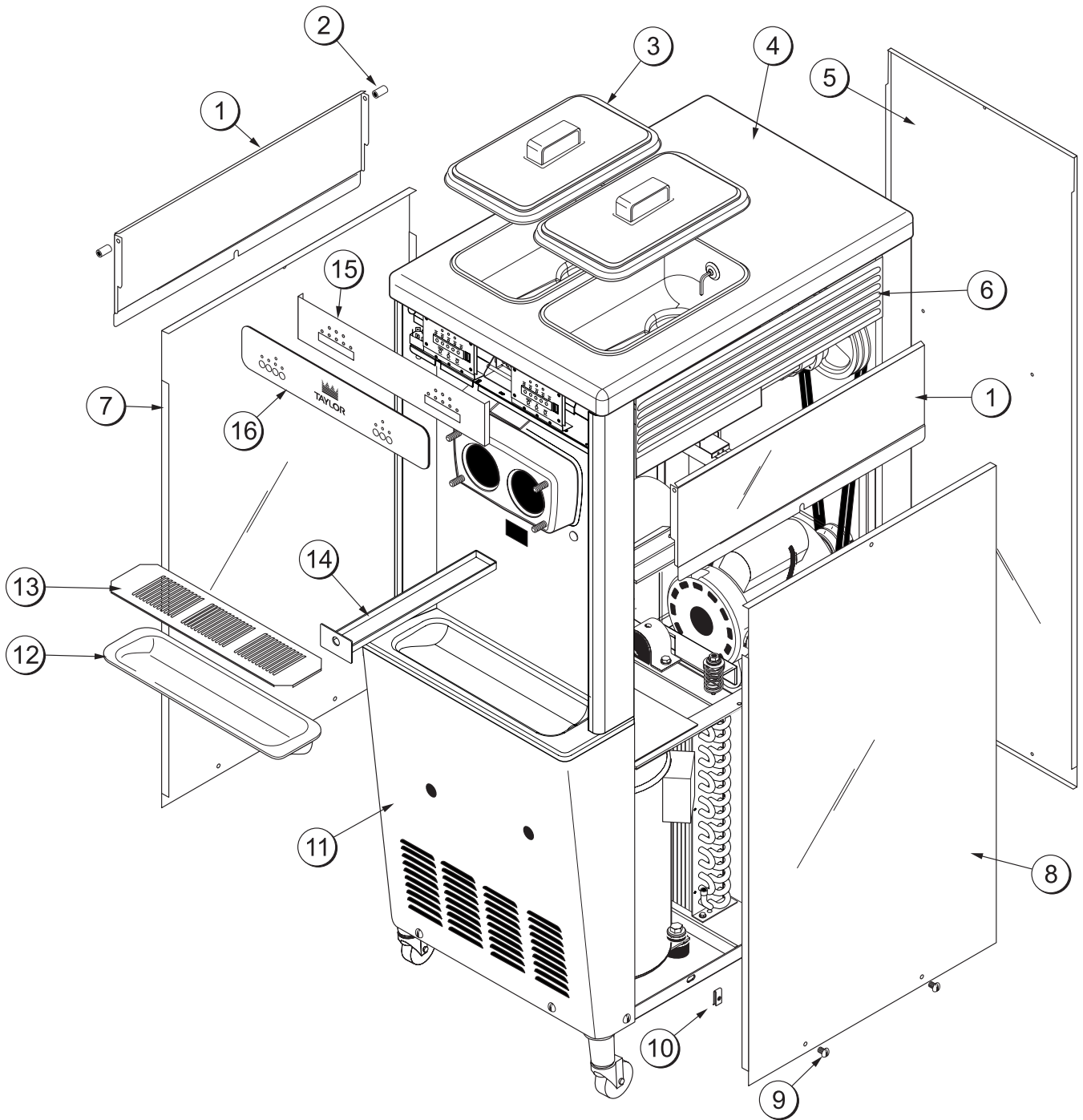

### Model 794 Panel Identification

ITEM	DESCRIPTION	PART NO.
1	PANEL-UPPER SIDE	024426
2	BUSHING-PANEL	013289
3	COVER-HOPPER-14 QT-GRAY	041682-GRY
4	HOOD	041665
5	PANEL-REAR	041855
6	LOUVER-SIDE	017471
7	PANEL A.-SIDE LOWER L.	X46447
8	PANEL A.-SIDE LOWER R.	X46448
9	SCREW-1/4-20 X 3/8 RHM SS	011694

ITEM	DESCRIPTION	PART NO.
10	FASTENER-CLIP	045865
11	PANEL-SERVICE	041856
12	TRAY-DRIP 16-7/8L X 5-1/8	020157
13	SHIELD-SPLASH	022765
14	PAN-DRIP 19-1/2 LONG	035034
15	PLATE-DEC	041854
16	DECAL-DEC-TAYLOR	045812
*17	TRIM-REAR CORNER-RIGHT	041853
*18	TRIM-REAR CORNER-LEFT	041852

\*NOT SHOWN

# Control A. - X38324-27A (Model 336)

208-230/60/1

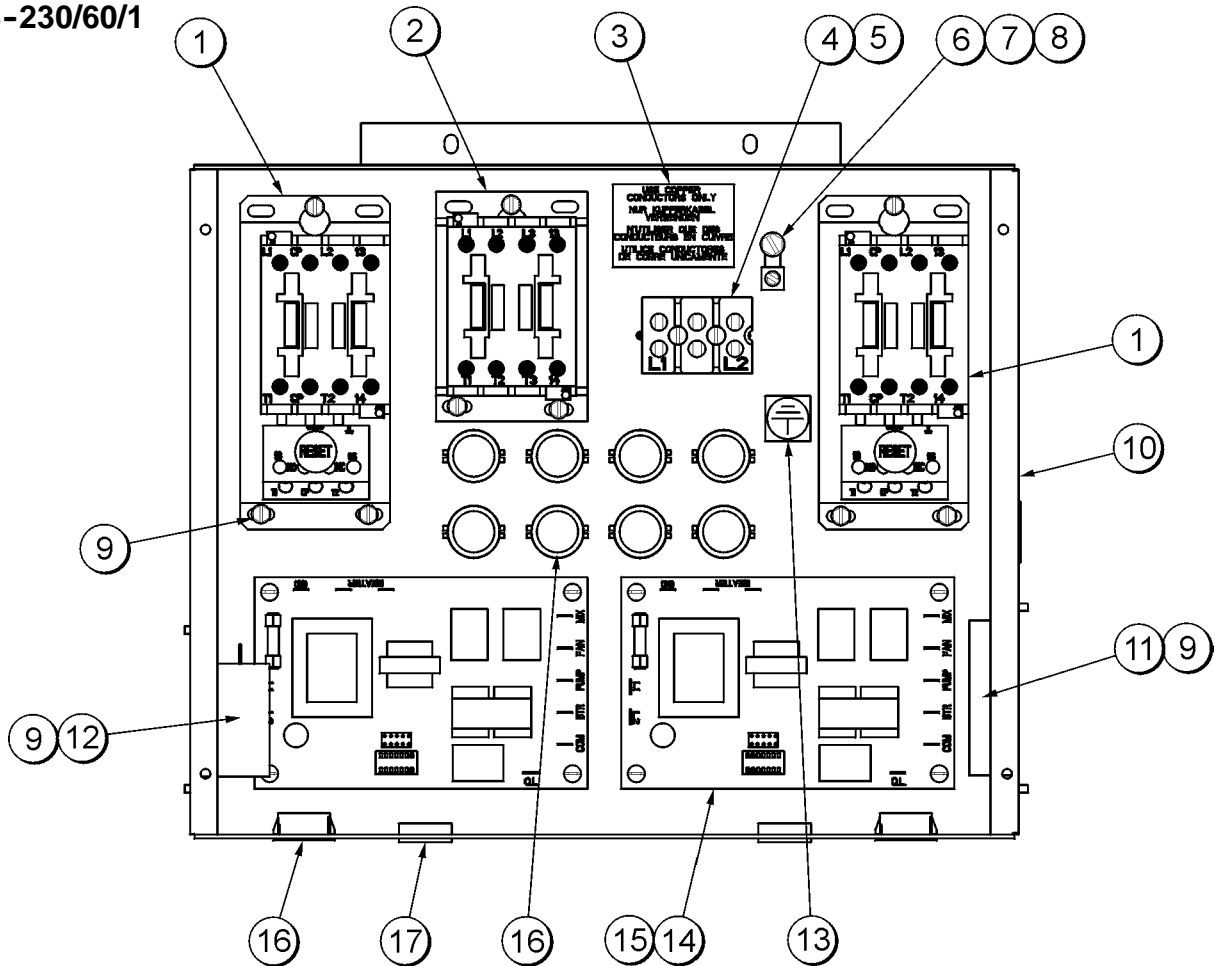

ITEM	DESCRIPTION	PART NO.
1	STARTER- PH-4.5 TO 7 A	041950-27K
2	RELAY-3 POLE	012725-33
3	LABEL-COPPER COND	025948
4	SCREW-8 X 1-1/4 RD HD - B	039420
5	BLOCK-TERMINAL 2P-L1,L2	039422
6	LUG-GROUNDING	020928
7	SCREW-10-32X1/2 MF HEX	020982
8	NUT-10-32 MF LOCK	020983
9	SCREW-8X1/4 SL HEX HD	009894

ITEM	DESCRIPTION	PART NO.
10	BOX A.-CONTROL	X36468
11	BLOCK-TERMINAL 5 POLE	024329
12	RELAY-SPST	032607-27
13	LABEL-GROUNDING	017669
14	BOARD-POWER-GEN 1 & 2	X32326-SER
*14a	FUSE-SLO BLO	051272
15	SCREW-6-32X5/8 RHM-SS	019309
16	PLUG-HOLE 7/8 DIA.	010077
17	BUSHING-SPLIT 43/64 ID	027691

\*NOT SHOWN



# Control A. - X42865-27 (Model 338)

208-230/60/1

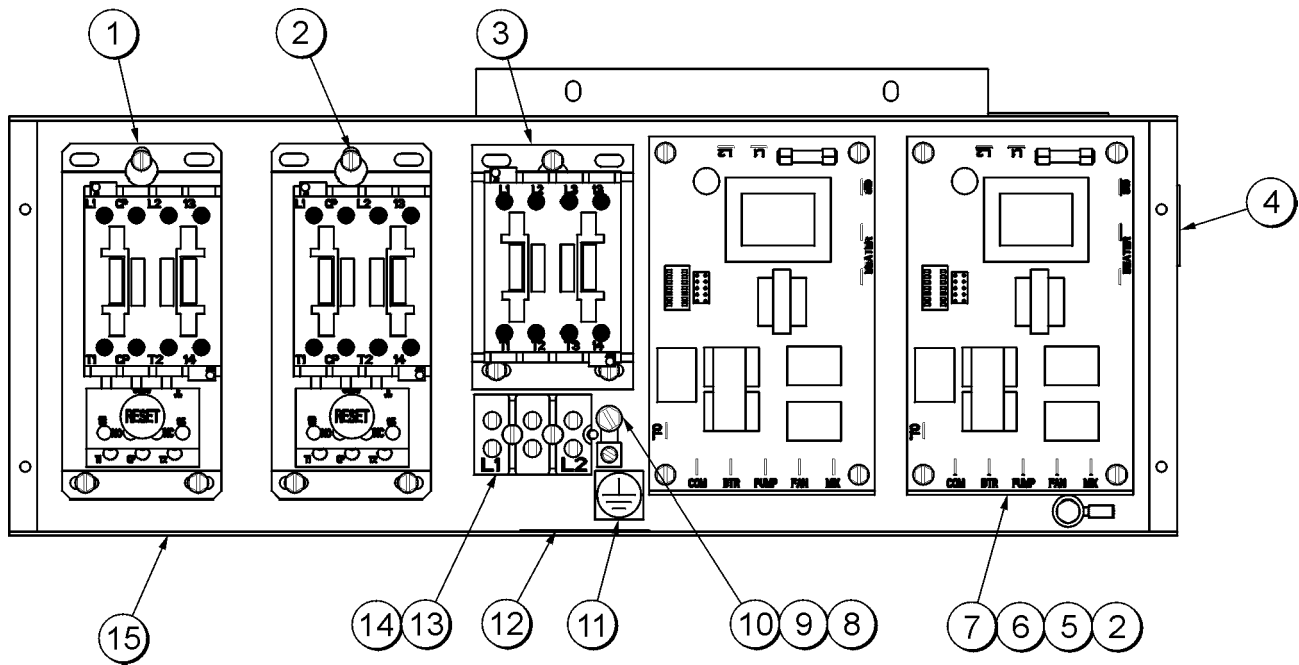

ITEM	DESCRIPTION	PART NO.
1	STARTER-1 PH-4.5 TO 7 A	041950-27K
2	SCREW-8X1/4 SL HEX HD B	009894
3	RELAY-3 POLE-20A-208/240	012725-33
4	BUSHING-SNAP	023396
5	BRACKET-POWER BOARD	042898
6	SCREW-6-32X5/8 HEX	041363
7	BOARD-POWER-GEN 1 & 2	X32326-SER
*7a	FUSE-SLO BLO	051272
8	LUG-GROUNDING	020928

ITEM	DESCRIPTION	PART NO.
9	SCREW-10-32X1/2 MF HEX	020982
10	NUT-10-32 MF LOCK	020983
11	LABEL-GROUNDING	017669
12	LABEL-COPPER COND ONLY	025948
13	SCREW-8 X 1-1/4 RD HD B	039420
14	BLOCK-TERMINAL 2P-L1,L2	039422
15	BOX A.-CONTROL	X42896
*16	CABLE-RIBBON 14C-30"L	035683
*17	CABLE-RIBBON 14C-40"L	042931

\*NOT SHOWN

# Control A. - X32963-27A (Models 339 & 754)

208-230/60/1

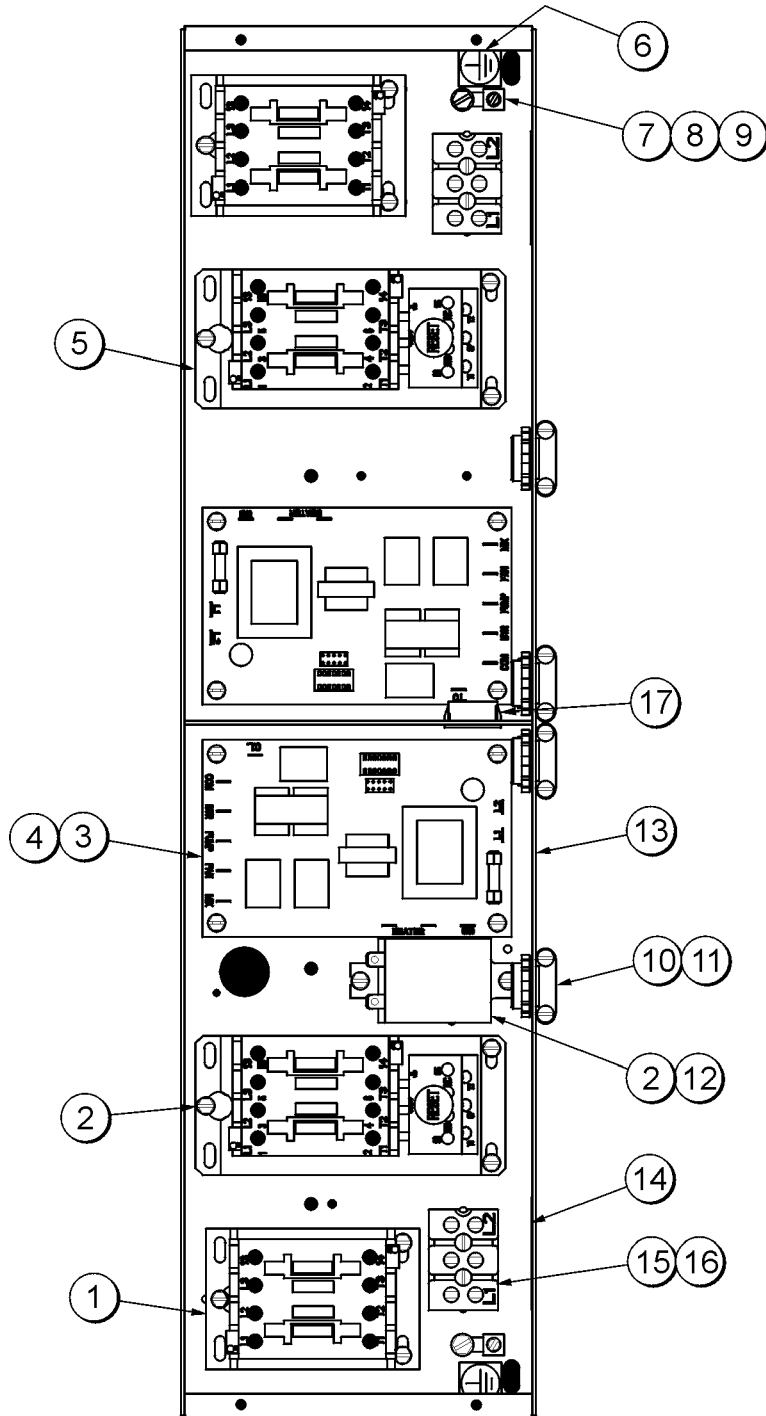

**Control A. - X32963-27A Parts Identification List**

ITEM	DESCRIPTION	PART NO.
1	RELAY-3 POLE-20A-208/240 50	012725-33
2	SCREW-8X1/4 SL HEX HD	009894
3	BOARD-POWER-GEN 1 & 2	X32326-SER
*3a	FUSE-SLO BLO	051272
4	SCREW-6-32X5/8 TAPTITE	041363
5	STARTER-1 PHASE-4.5 TO 7 A	041950-27K
6	LABEL-GROUNDING SYMBOL	017669
7	LUG-GROUNDING 260	020928
8	SCREW-10-32X1/2 MF HEX	020982
9	NUT-10-32 MF LOCK	020983

ITEM	DESCRIPTION	PART NO.
10	BUSHING-SPLIT 43/64ID	027691
11	CONNECTOR-BX 3/8 STR	014569
12	RELAY-SPDT-30 A-240 V	032607-27
13	BOX A.-CONTROL *754 MC*	X32958
14	LABEL-COPPER COND ONLY	025948
15	SCREW-8 X 1-1/4 RD HD	039420
16	BLOCK-TERMINAL 2P-L1,L2	039422
17	BUSHING-SNAP 11/16IDX7/8	010548
*18	CABLE-RIBBON-PWR/ RELAY-66"	042599

\*NOT SHOWN

# Control A. - X52614-27 (Model 750)

208-230/60/1

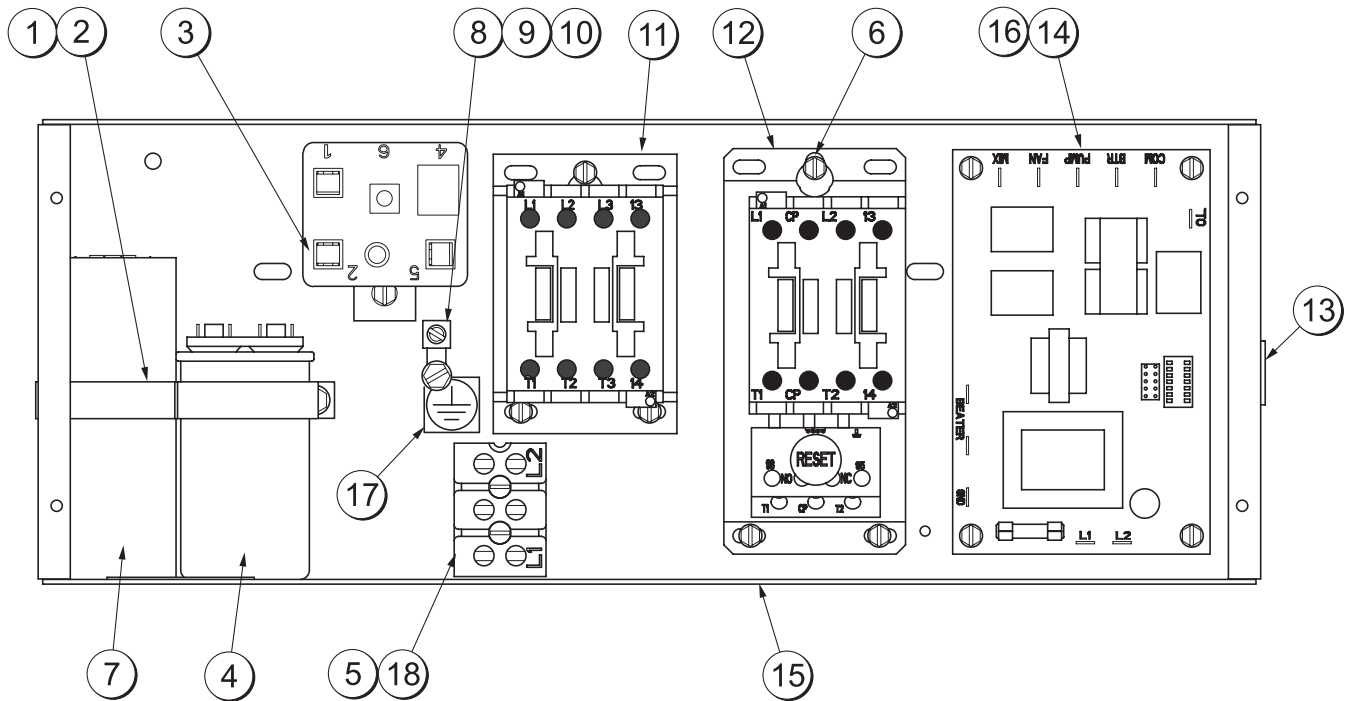

ITEM	DESCRIPTION	PART NO.
1	STRAP-CAPACITOR	037890
2	SCREW-10 X 3/8 TYPE B-HEX	015582
3	RELAY-START-COMPRESSOR	051957-27
4	CAPACITOR-RUN 20 UF/440V	012906
5	BLOCK-TERMINAL 2P-L1,L2	039422
6	SCREW-8X1/4 SL HEX HD	009894
7	CAPACITOR-START-189-227U F	033044-1
8	LUG-GROUNDING 260	020928
9	SCREW-10-32X1/2 MF HEX	020982
10	NUT-10-32 MF LOCK	020983

ITEM	DESCRIPTION	PART NO.
11	RELAY-3 POLE-20A-208/240 50	012725-33
12	STARTER-1 PHASE-4.5 TO 7 A	041950-27K
13	BUSHING-SPLIT 43/64ID	027691
14	SCREW-6-32X5/8 TAPTITE	041363
15	BOX-CONTROL	050735
16	BOARD-POWER-GEN 1 & 2	X32326-SER
*16a	FUSE-SLO BLO	051272
17	LABEL-GROUNDING SYMBOL	017669
18	SCREW-8 X 1-1/4 RD HD TYP B	039420

\*NOT SHOWN

# Control A. - X47194-27A (Models 751/8751)

208-230/60/1

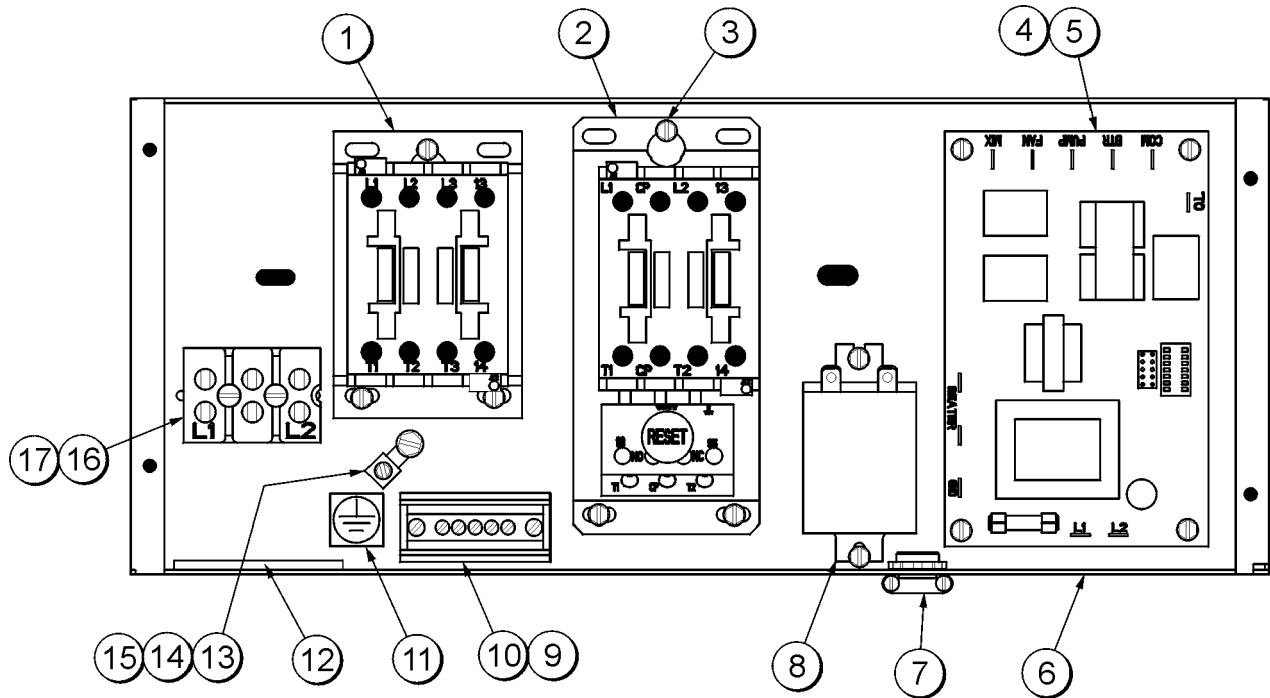

ITEM	DESCRIPTION	PART NO.
1	RELAY-3 POLE-20A-208/240	012725-33
2	STARTER-1 PH-4.5 TO 7 A	041950-27K
3	SCREW-8X1/4 SL HEX HD	009894
4	SCREW-6-32X5/8 TAPTITE	041363
5	BOARD-POWER-GEN 1 & 2	X32326-SER
*5a	FUSE-SLO BLO	051272
6	BOX-CONTROL	033252
7	CONNECTOR-BX 3/8 STR	014569
8	RELAY-SPDT-30 A-240 V	032607-27
9	SCREW 8 X 1/2 PAN HD	017986

ITEM	DESCRIPTION	PART NO.
10	BLOCK-TERMINAL-7 POLE	024156
11	LABEL-GROUNDING SYMBOL	017669
12	LABEL-COPPER COND ONLY	025948
13	LUG-GROUNDING 260	020928
14	SCREW-10-32X1/2 MF HEX	020982
15	NUT-10-32 MF LOCK	020983
16	SCREW-8 X 1-1/4 RD HD	039420
17	BLOCK-TERMINAL 2P-L1,L2	039422
*18	CABLE-RIBBON-PWR/RELAY	032445

\*NOT SHOWN

# Control A. - X42603-27A (Model 774)

208-230/60/1

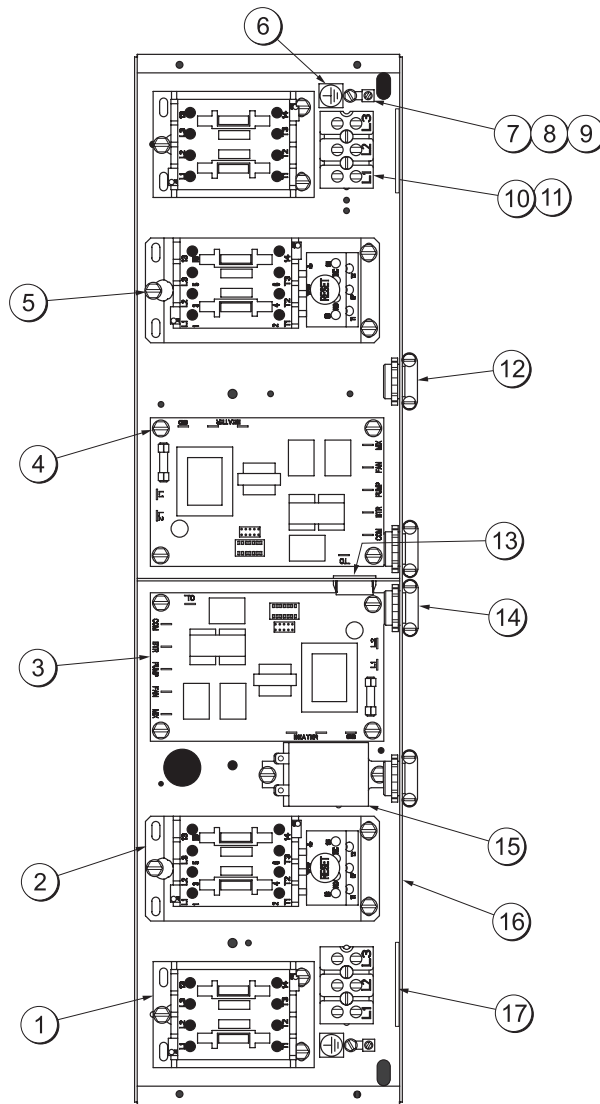

ITEM	DESCRIPTION	PART NO.
1	RELAY-3 POLE-20A-208/240	012725-33
2	STARTER-1 PHASE-4.5 TO 7	041950-27K
3	BOARD-POWER-GEN 1 & 2	X32326-SER
*3a	FUSE-SLO BLO	051272
4	SCREW-6-32X5/8 TAPTITE	041250
5	SCREW-8X1/4 SL HEX HD B	009894
6	LABEL-GROUNDING	017669
7	LUG-GROUNDING	020928
8	SCREW-10-32X1/2 MF HEX	020982
9	NUT-10-32 MF LOCK	020983

ITEM	DESCRIPTION	PART NO.
10	SCREW-8 X 1-1/4 RD HD	039420
11	BLOCK-TERMINAL 2P-L1,L2	039422
	BLOCK-TERMINAL 3P-L1,2,3	039423
12	CONNECTOR-BX 3/8 STR	014569
13	BUSHING-SNAP 11/16ID	010548
14	BUSHING-SPLIT 43/64ID	027691
15	RELAY-SPDT-30 A-240 V	032607-27
16	BOX A.-CONTROL	X32958
17	LABEL-COPPER COND ONLY	025948

\*NOT SHOWN

# Control A. - X48236-27A (Model 794)

208-230/60/1

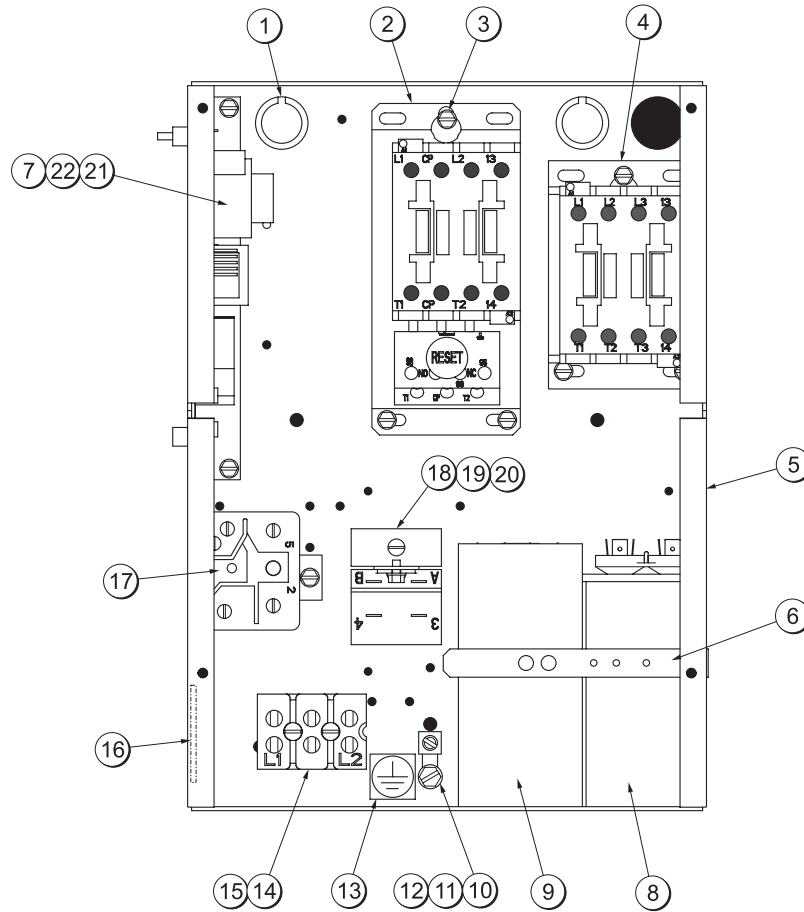

ITEM	DESCRIPTION	PART NO.
1	BUSHING-SPLIT 43/64 ID	027691
2	STARTER-1 PHASE-4.5 - 7 A	041950-27K
3	SCREW-8X1/4 SL HEX HD	009894
4	RELAY-3 POLE-20A-208/240	012725-33
5	BOX-CONTROL	048335
6	STRAP-CAPACITOR 7-11/32	037890
7	BRACKET-POWER BOARD	042751
8	CAPACITOR-RUN 35UF/440V	048132
9	CAPACITOR-START 135-155	036048
10	LUG-GROUNDING	020928
11	SCREW-10-32X1/2 MF HEX	020982
12	NUT-10-32 MF LOCK	020983

ITEM	DESCRIPTION	PART NO.
13	LABEL-GROUNDING	017669
14	SCREW-8 X 1-1/4 RD HD	039420
15	BLOCK-TERMINAL 2P-L1, L2	039422
16	LABEL-COPPER COND.	025948
17	RELAY-START-COMP.	036047
18	RELAY-SPDT 30 A-240 V	032607-27
19	SCREW-6-32 X 3/8 BIN. HD	002201
20	BRACKET-RELAY	048304
21	BOARD-POWER-GEN 1 & 2	X32326-SER
*21a	FUSE-SLO BLO	051272
22	SCREW-6-32 X 5/8 HEX	041363
*23	CABLE-RIBBON-PWR/RELAY	032445

\*NOT SHOWN

# Control A. - X48237-27 (Model 794)

208-230/60/1

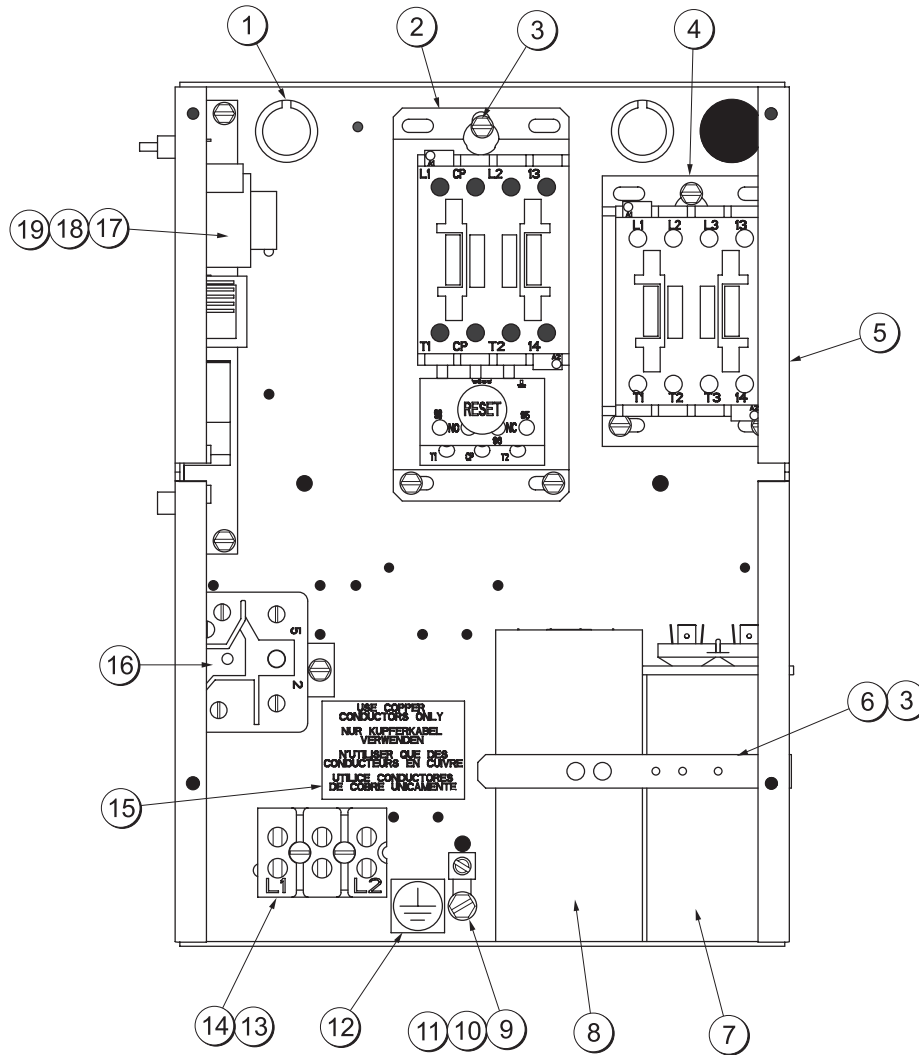

Item	Description	Part No.
1	BUSHING-SPLIT 43/64 ID	027691
2	STARTER-1 PHASE-4.5 TO 7 A	041950-27K
3	SCREW-8X1/4 SL HEX HD B	009894
4	RELAY-3 POLE-20A-208/240	012725-33
5	BOX-CONTROL	048335
6	STRAP-CAPACITOR 7-11/32	037890
7	CAPACITOR-RUN- 35UF/440V	048132
8	CAPACITOR-START-135-155	036048
9	LUG-GROUNDING 260	020928
10	SCREW-10-32X1/2 MF HEX	020982
11	NUT-10-32 MF LOCK	020983

Item	Description	Part No.
12	LABEL-GROUNDING SYMBOL	017669
13	SCREW-8 X 1-1/4 RD HD	039420
14	BLOCK-TERMINAL 2P-L1,L2	039422
15	LABEL-COPPER COND ONLY	025948
16	RELAY-START-COMPRESSOR	036047
17	BOARD-POWER-GEN 1 & 2	X32326-SER
17a	FUSE-SLO BLO	051272
18	SCREW-6-32X5/8 TAPTITE	041363
19	BRACKET-POWER BOARD	042751
*20	CABLE-RIBBON-PWR/RELAY	032445

\*NOT SHOWN



# Box A.-Cap & Relay - X48535-27

208-230/60/1

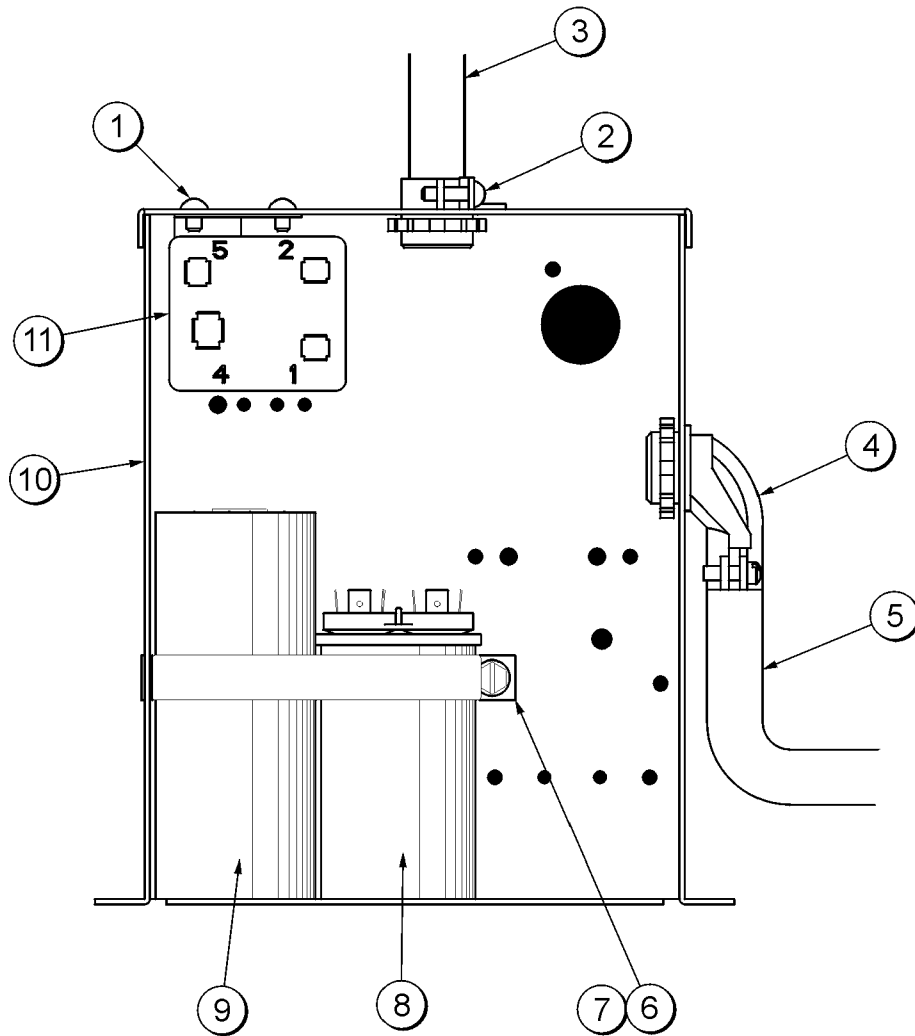

ITEM	DESCRIPTION	PART NO.
1	SCREW-8-32 X 1/4 RHM	000953
2	CONNECTOR-BX 3/8 STR	014569
3	SLEEVE-WIRE 1/2 I.D. X .031	022175-15
4	CONNECTOR-BX 3/8 90DEG	001793
5	SLEEVE-WIRE 1/2 I.D. X .031	022175-24
6	SCREW-10 X 3/8 TYPE B	015582

ITEM	DESCRIPTION	PART NO.
7	STRAP-CAPACITOR 5-5/8 IN.	030258
8	CAPACITOR-RUN- 20UF/440V	012906
9	CAPACITOR-START-161-193UF	031790
10	BOX-CAPACITOR RELAY	030183
11	RELAY-START-COMPRESSOR	038145
*12	COVER-CAP.RELAY BOX	030315

\*NOT SHOWN

# Box A.-Cap & Relay - X51593-27 (Model 338)

208-230/60/1

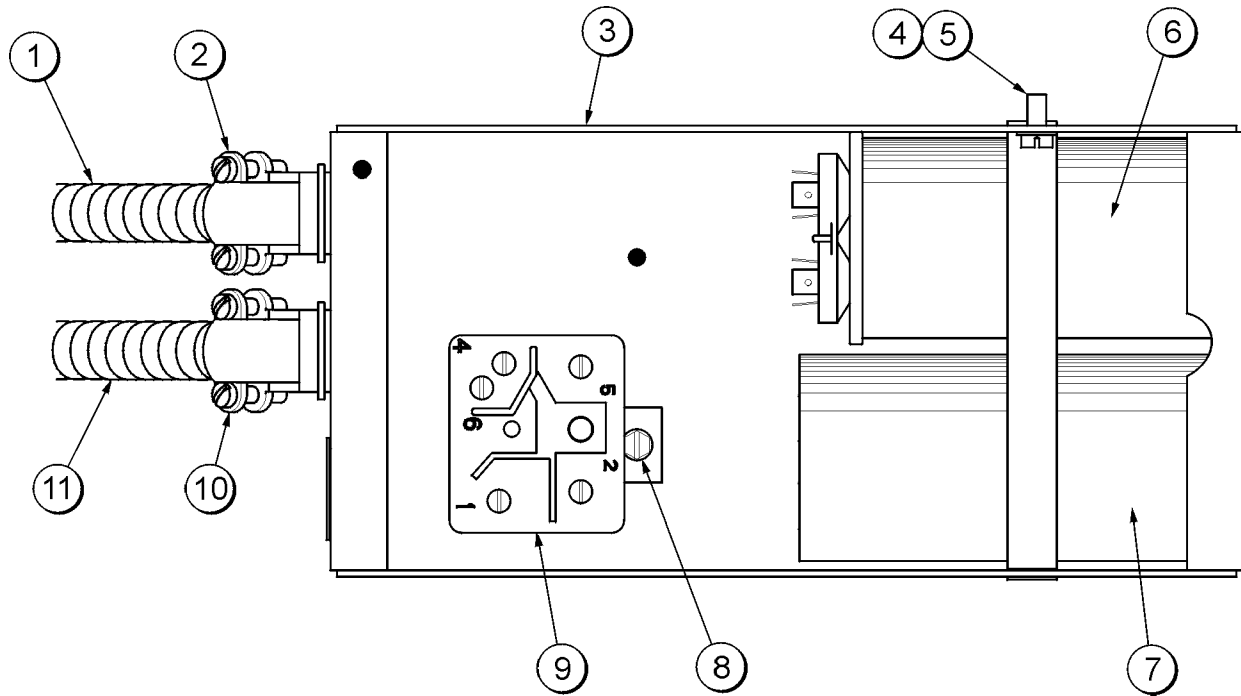

ITEM	DESCRIPTION	PART NO.
1	GREENFIELD-3/8	020495-12
2	CONNECTOR-BX 3/8 90D	001793
3	BOX-CAPACITOR RELAY	038229
4	SCREW-10 X 3/8 TYPE B-HEX	015582
5	STRAP-CAPACITOR 5-5/8 IN.	030258
6	CAPACITOR-RUN- 35UF/440V	048132
7	CAPACITOR-START-135-155	036048

ITEM	DESCRIPTION	PART NO.
8	SCREW-8X1/4 SL HEX HD B	009894
9	RELAY-START-COMPRESSOR	036047
10	CONNECTOR-BX 3/8 45D	010687
11	GREENFIELD-3/8	020495-30
*	PLUG-HOLE 7/8 DIA.	010077
*	BUSHING-ANTI-SHORT 3/8	019117
*	COVER-CAP.RELAY BOX	044530

\*NOT SHOWN

# Box A.-Cap & Relay - X52665-27 (Model 339)

208-230/60/1

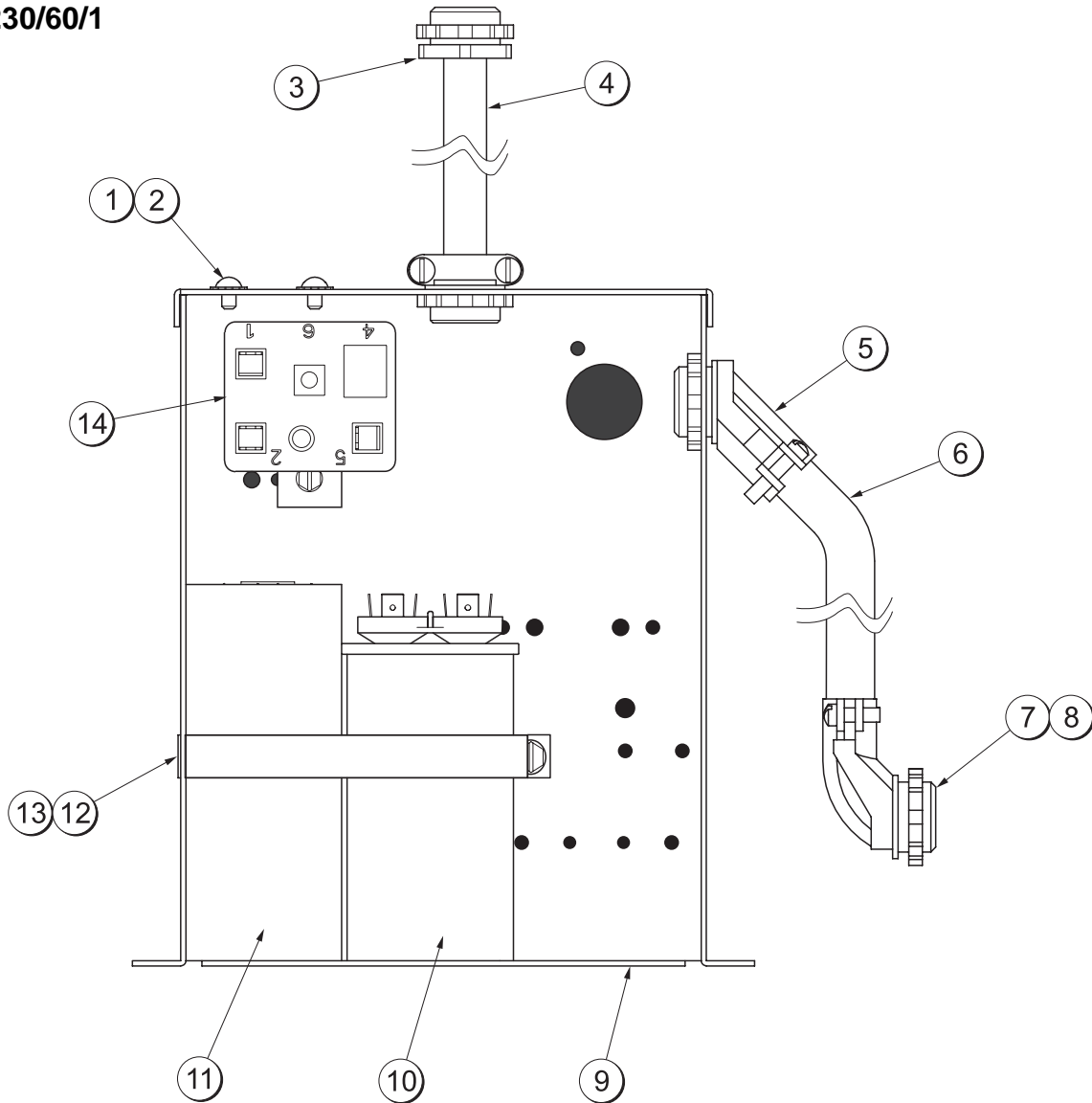

ITEM	DESCRIPTION	PART NO.
1	SCREW-8-32 X 1/4 RHM-BR	000953
2	WASHER-#8 SHAKEPROOF	000964
3	CONNECTOR-BX 3/8 STR	001791
4	GREENFIELD-3/8	020495-
5	CONNECTOR-BX 3/8 45D	010687
6	SLEEVE-WIRE 1/2 ID X .031	022175-
7	CONNECTOR-BX 3/8 90D	001793
8	BUSHING-ANTI-SHORT 3/8	019117

ITEM	DESCRIPTION	PART NO.
9	BOX-CAPACITOR RELAY	030183
10	CAPACITOR-RUN- 35 UF/370V	029439
11	CAPACITOR-START-189-227	033044-1
12	SCREW-10 X 3/8 TYPE B-HEX	015582
13	STRAP-CAPACITOR 5-5/8 IN.	030258
14	RELAY-START-COMP.	052401-27
*	COVER-CAP.RELAY BOX	030315
*	LABEL-WIRING SINGLE PH	036880-2

\*NOT SHOWN

# Box A.-Cap & Relay - X50317-27 (Model 751)

208-230/60/1

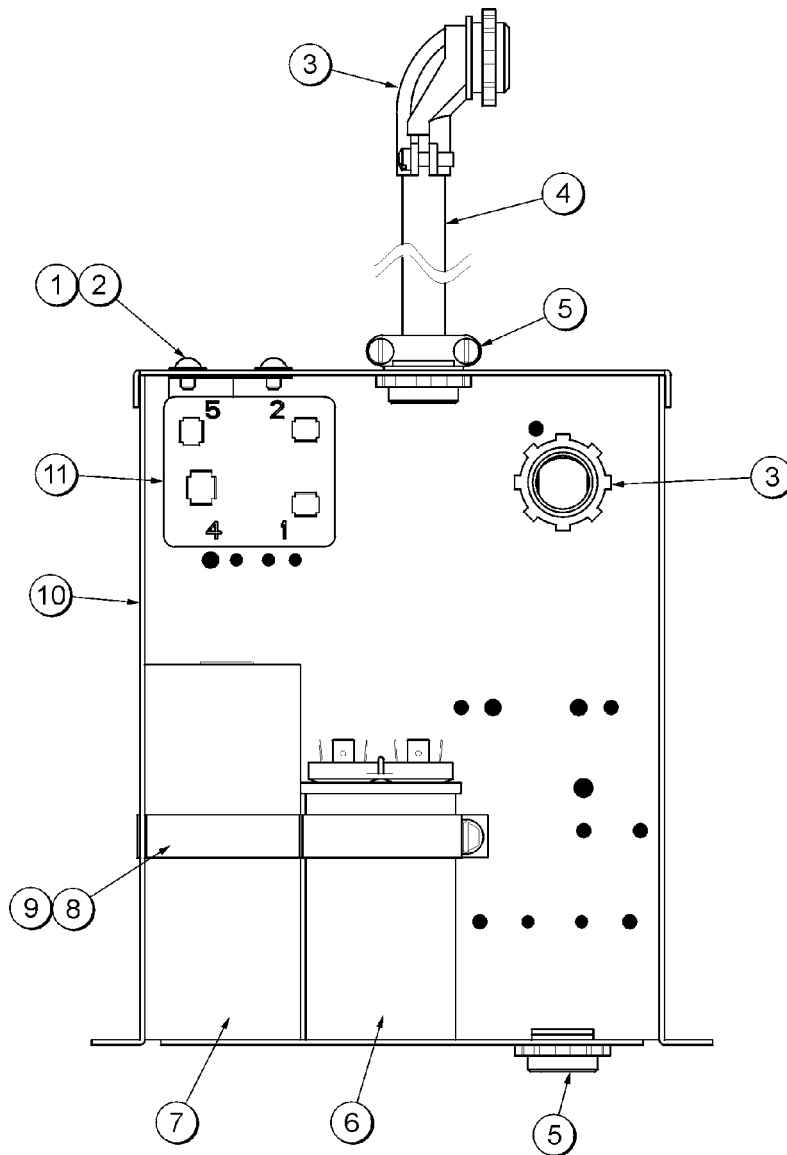

ITEM	DESCRIPTION	PART NO.
1	SCREW-8-32 X 1/4 RHM	000953
2	WASHER-#8 -EXTERNAL	000964
3	CONNECTOR-BX 3/8 90D	001793
4	SLEEVE-WIRE 7/16 ID	020919-
5	CONNECTOR-BX 3/8 STR	014569
6	CAPACITOR-RUN- 20UF/440V	012906
7	CAPACITOR-START-161-193	031790

ITEM	DESCRIPTION	PART NO.
8	STRAP-CAPACITOR 5-5/8 IN.	030258
9	SCREW-10 X 3/8 TYPE B-HEX	015582
10	BOX-CAPACITOR RELAY	030183
11	RELAY-START-COMP.	038145
*	COVER-CAP.RELAY BOX	030315
*	LABEL-WIRING SINGLE PH	036880-2

\*NOT SHOWN

# Box A.-Cap & Relay - X50297-27 (Model 754)

208-230/60/1

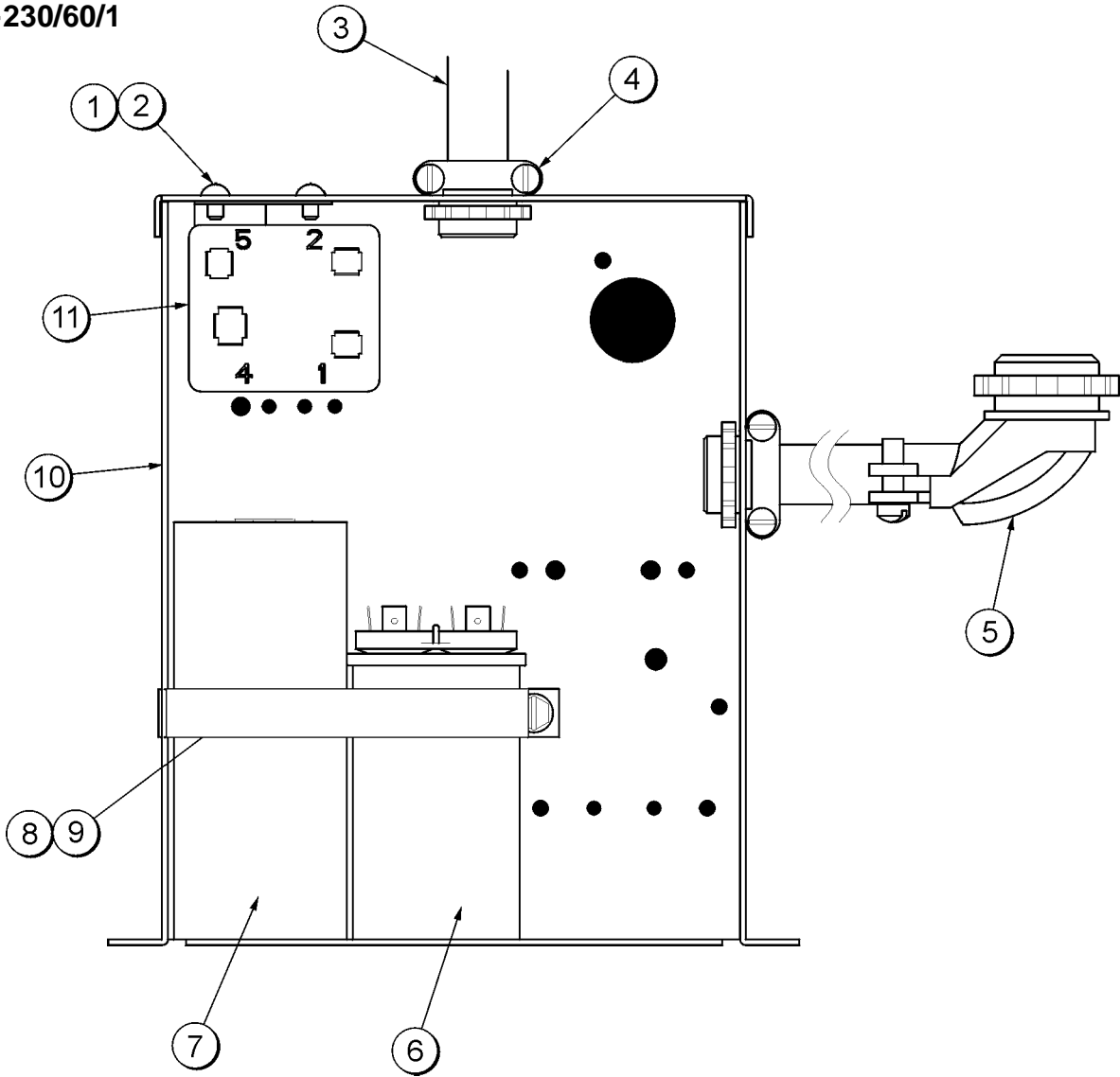

ITEM	DESCRIPTION	PART NO.
1	SCREW-8-32 X 1/4 RHM-BR.	000953
2	WASHER-#8 -EXTERNAL	000964
3	SLEEVE-WIRE 7/16 ID	020919-
4	CONNECTOR-BX 3/8 STR	014569
5	CONNECTOR-BX 3/8 90D	001793
6	CAPACITOR-RUN- 20UF/440V	012906
7	CAPACITOR-START-161-193	031790

ITEM	DESCRIPTION	PART NO.
8	SCREW-10 X 3/8 TYPE B-HEX	015582
9	STRAP-CAPACITOR 5-5/8 IN.	030258
10	BOX-CAPACITOR RELAY	030183
11	RELAY-START-COMP.	038145
*	COVER-CAP.RELAY BOX	030315
*	LABEL-WIRING SINGLE PH	036880-2

\*NOT SHOWN

# Box A.-Cap & Relay - X50373-27 (Model 774)

208-230/60/1

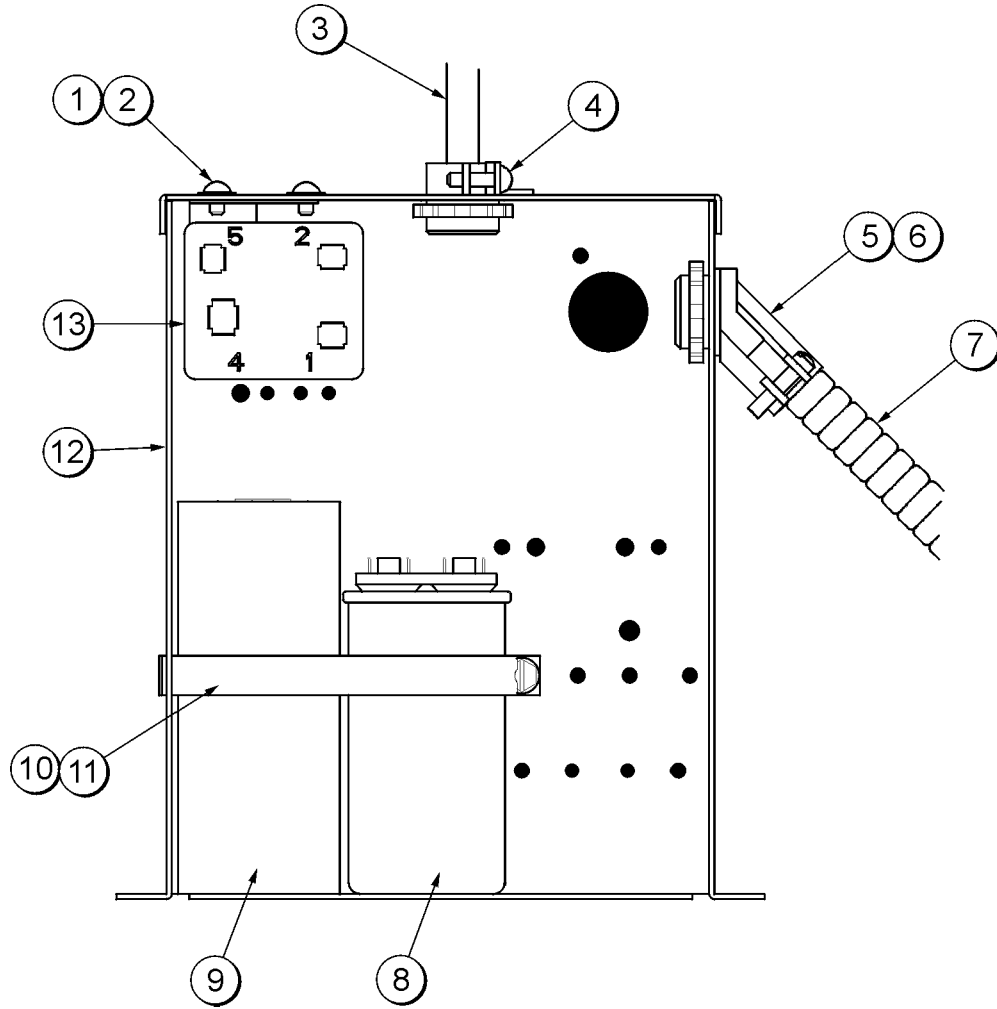

ITEM	DESCRIPTION	PART NO.
1	SCREW-8-32 X 1/4 RHM-BR.	000953
2	WASHER-#8-EXTERNAL	000964
3	SLEEVE-WIRE .330 ID	020918
4	CONNECTOR-BX 3/8 STR	014569
5	CONNECTOR-BX 3/8 45D	010687
6	BUSHING-ANTI-SHORT 3/8	019117
7	GREENFIELD-3/8	020495-
8	CAPACITOR-RUN- 20UF/440V	012906

ITEM	DESCRIPTION	PART NO.
9	CAPACITOR-START-161-193	031790
10	STRAP-CAPACITOR 5-5/8 IN.	030258
11	SCREW-10 X 3/8 TYPE B-HEX	015582
12	BOX-CAPACITOR RELAY	030183
13	RELAY-START-COMPRESSOR	038145
*	COVER-CAP. RELAY BOX	030315
*	LABEL-WIRING SINGLE PH	036880-2

\*NOT SHOWN

# Blower A. X53725-

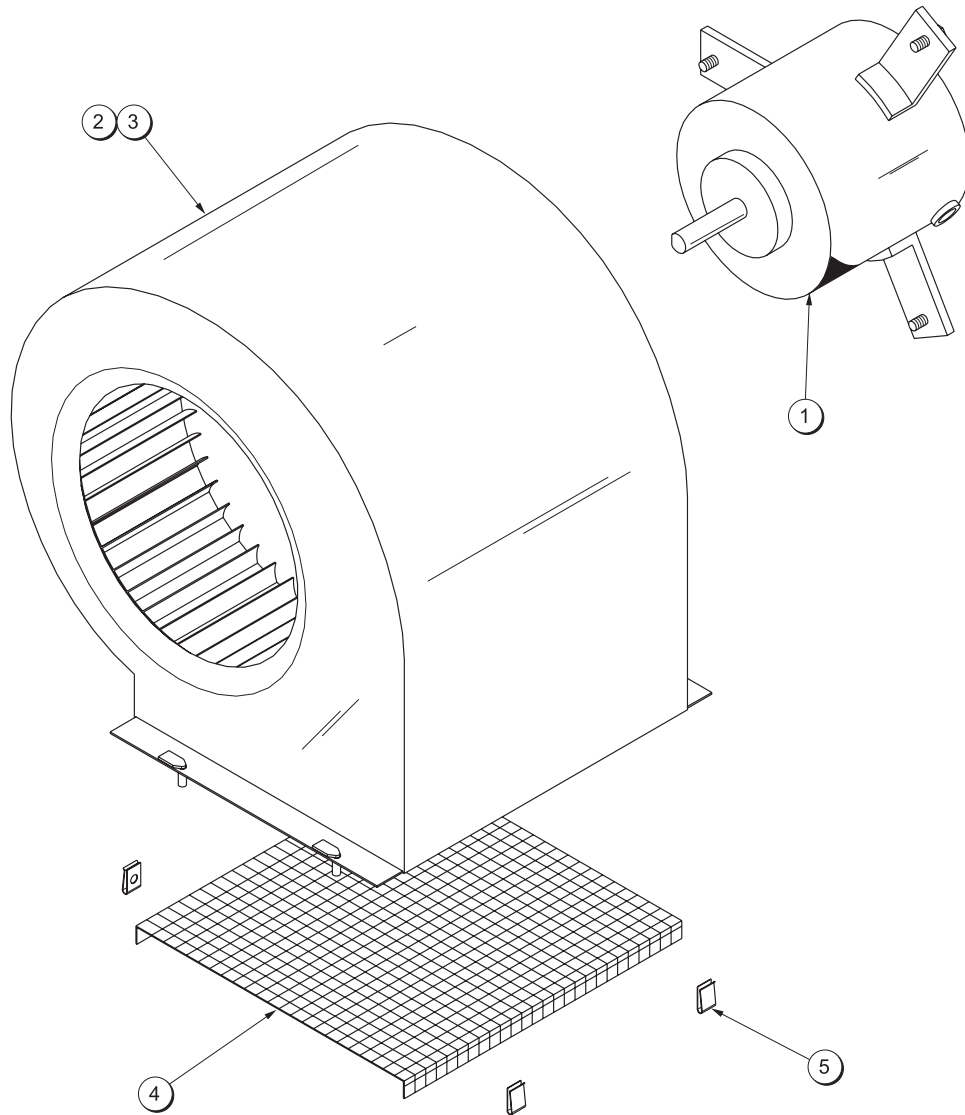

ITEM	DESCRIPTION	PART NO.
1	MOTOR-BLOWER-FAN	053481
2	WHEEL-BLOWER	053726
3	HOUSING-BLOWER-6 POLE	053728

ITEM	DESCRIPTION	PART NO.
4	SCREEN-BLOWER	053729
5	CLIP-SCREEN-BLOWER	053730

# Switch A.-Draw X43417-SER (Model 336)

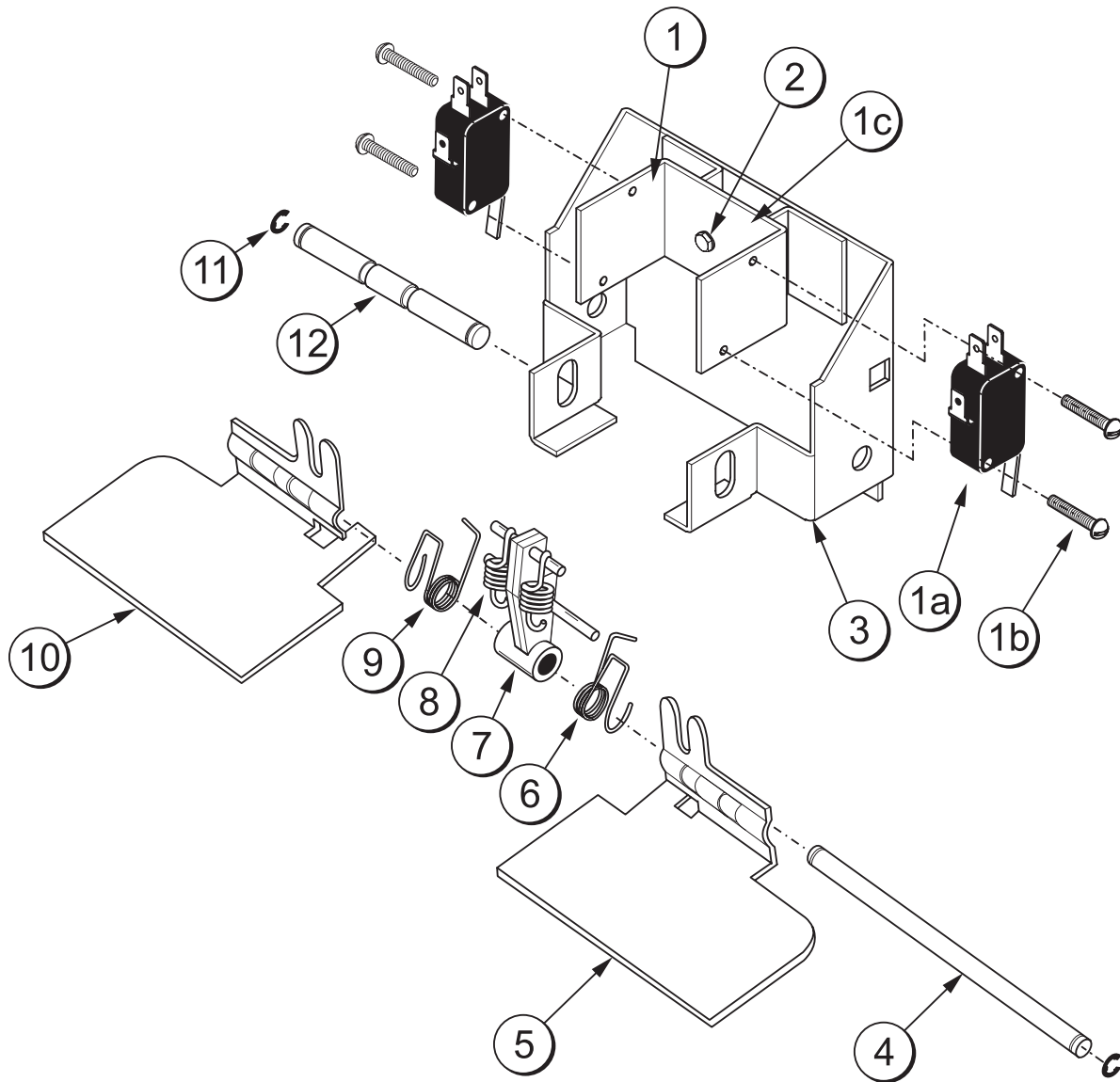

ITEM	DESCRIPTION	PART NO.
1	SWITCH A.-DRAW	X39269
1a	SWITCH-LEVER-SPDT-11A	039252
1b	SCREW-4-40 X1/2" TAPTITE	042604
1c	BRACKET-DRAW SWITCH	039264
2	SCREW-8-32x3/8 HEX HEAD	039267
3	BRACKET A.-DRAW SWITCH	X43418
4	PIN-PIVOT-DRAW SWITCH	038484
5	ARM-SWITCH-DRAW-RIGHT	038650

ITEM	DESCRIPTION	PART NO.
6	SPRING-RETURN-RIGHT	038924
7	BRACKET A.-SPRING RETURN	X38257
8	SPRING-EXTENSION .375x.045	038922
9	SPRING-RETURN-LEFT	038923
10	ARM-SWITCH-DRAW-LEFT	038649
11	E-RING 1/4	032190
12	ROD-SPRING RETAINER	043422



# Switch A.-Draw X38547 (Models 338, 339, 754, 774, 794)

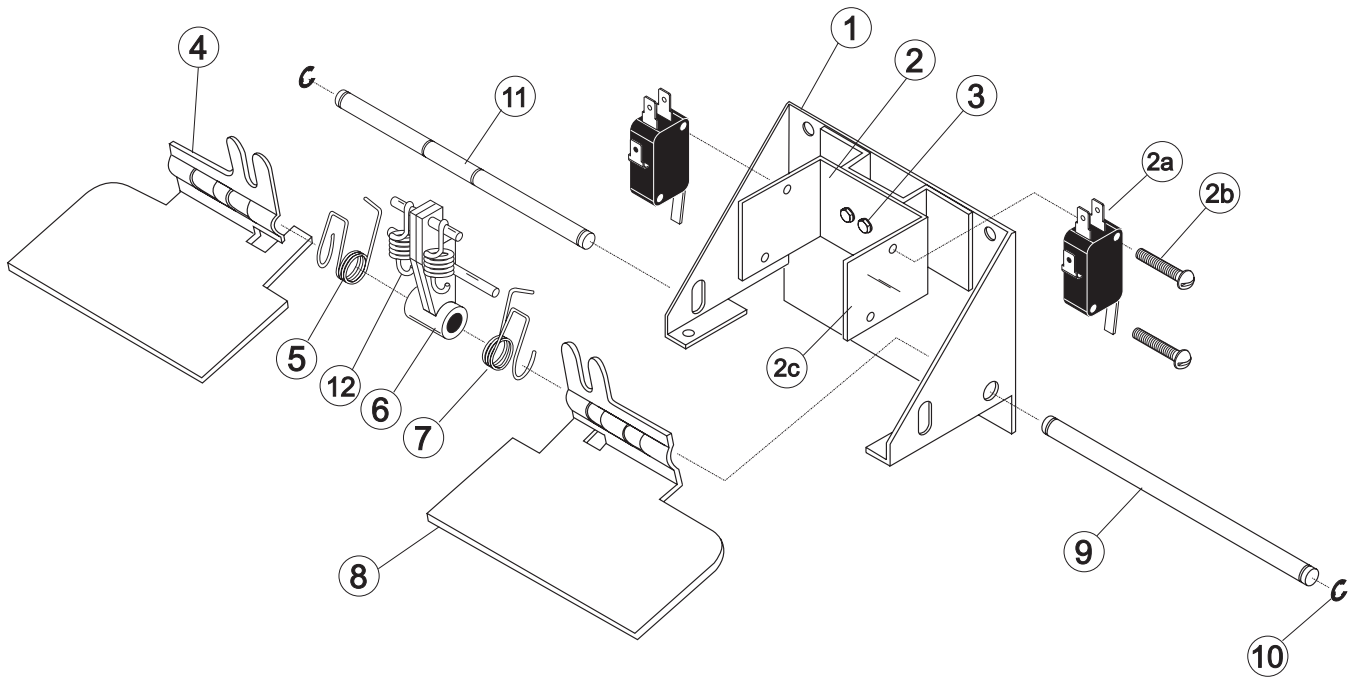

ITEM	DESCRIPTION	PART NO.
1	BRACKET A.-SWITCH	X38252
2	SWITCH A.-DRAW-TWIN TWIST	X39269
2a	SWITCH-LEVER-SPDT 11 A	039252
2b	SCREW-4-40 X 1/2" TAPTITE	042604
2c	BRACKET-DRAW SWITCH	039264
3	SCREW-8-32X3/8 HEX HD	039267
4	ARM-SWITCH-DRAW-LEFT	038649
5	SPRING-RETURN-LEFT	038923

ITEM	DESCRIPTION	PART NO.
6	BRACKET A.-SPRING RETURN	X38257
7	SPRING-RETURN-RIGHT	038924
8	ARM-SWITCH-DRAW-RIGHT	038650
9	PIN-PIVOT-DRAW SWITCH	038484
10	E-RING 1/4	032190
11	ROD-SPRING RETAINER	038254
12	SPRING-EXTENSION.375X.045	038922

# Switch A.-Draw X33322-SP (Models 750, 751)

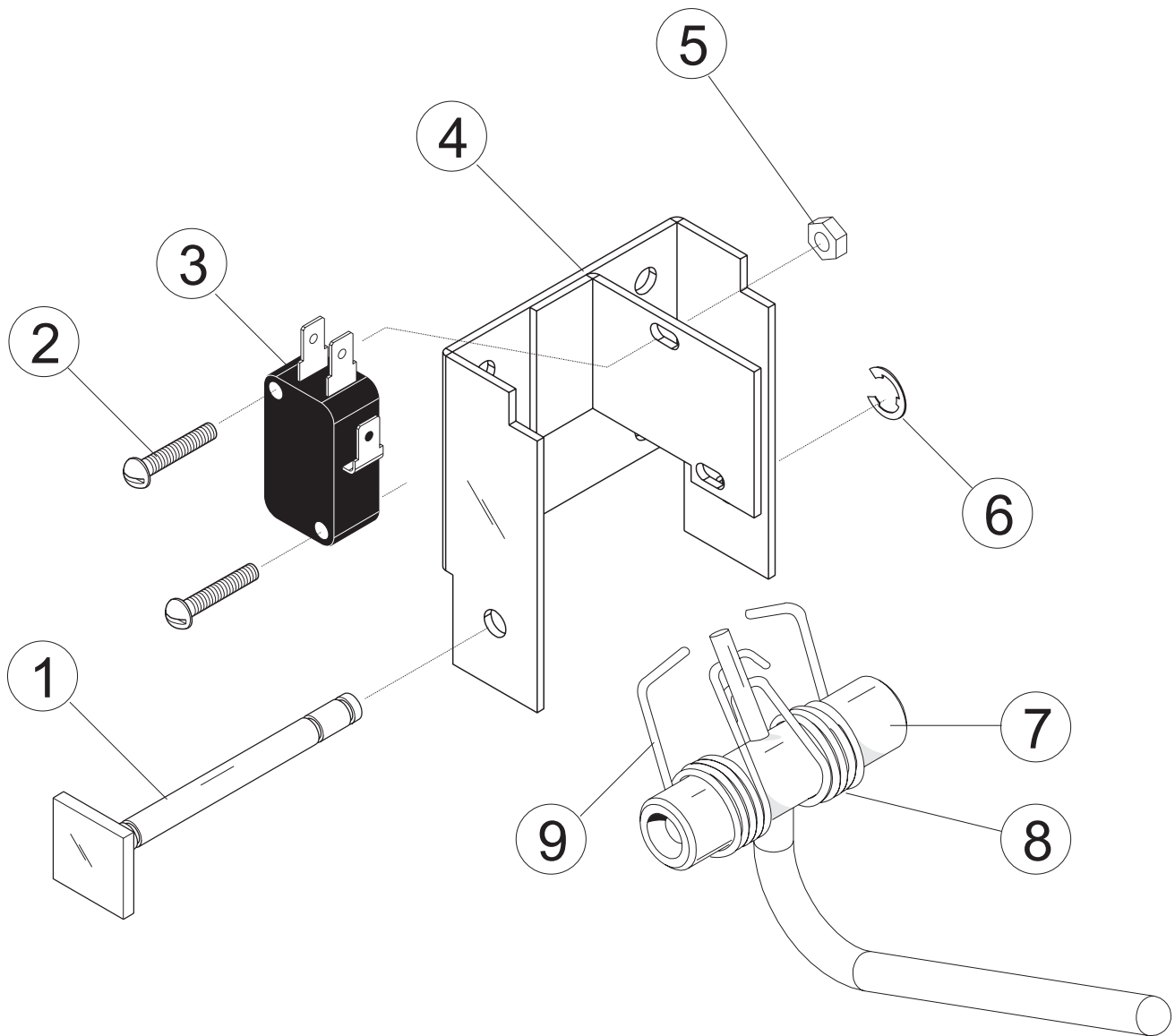

ITEM	DESCRIPTION	PART NO.
1	PIN-PIVOT	015478
2	SCREW-4-40 X 5/8 RHM-	027219
3	SWITCH-LEVER-SPDT-10A	028889
4	BRACKET A.-SWITCH	X43722
5	NUT-4-40 HEX -PLATED-	038623

ITEM	DESCRIPTION	PART NO.
6	E-RING 3/16 .335 O.D.	049178
7	ARM A.-DRAW *750-1-2*MC*	X33326
8	SPRING-RETURN-RIGHT	041661
9	SPRING-RETURN-LEFT	041660

# Air/Mix Pump-Soft Serve X45316-B

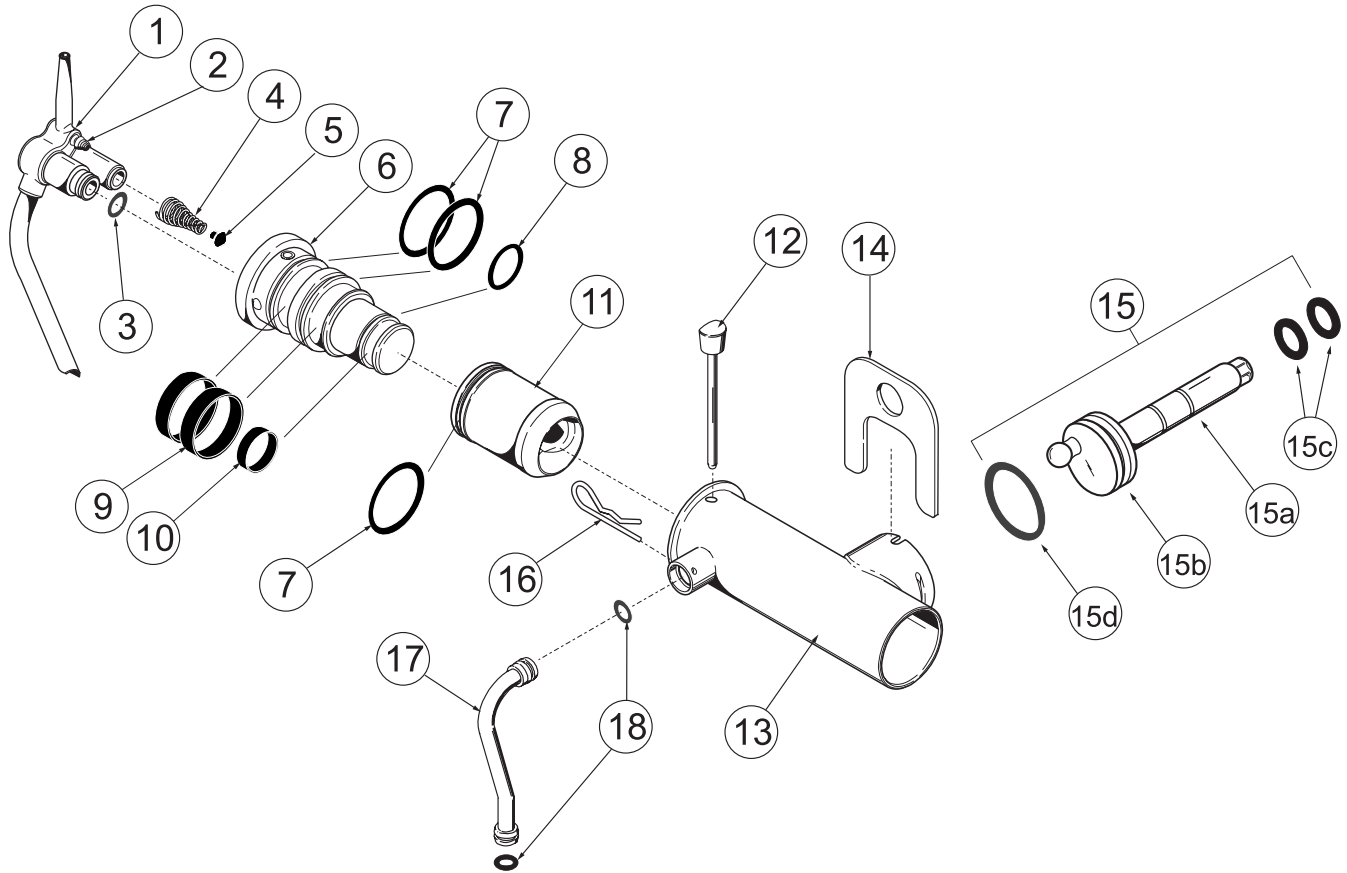

ITEM	DESCRIPTION	PART NO.
1	TUBE A.-MIX INLET	X45318
2	SEAL-AIR INLET FITTING	045327
3	O-RING-3/4 OD X .103W	015835
4	SPRING-TAPERED 1-7/8L	022456
5	POPPET-RUBBER-BLACK	022473
6	BODY A.-COAX VALVE	X46860-B
7	O-RING-2-1/8 OD X .139W-#225	020051
8	O-RING-1-3/8 OD X .103W-#123	018664
9	RING-CHECK 2 IN OD X 1/2	020050
10	RING-CHECK 1-1/4 OD X 3/8	033215
11	PISTON-COAX PUMP *B*HPR	045319-B
12	PIN A.-COAX PUMP *HT*SS*	X36950

ITEM	DESCRIPTION	PART NO.
13	CYLINDER A.-PUMP	X44755
14	CLIP-MIX PUMP RETAINER	044641
15	SHAFT A.-DRIVE-MIX PUMP	X39084
15a	SHAFT-PUMP-MIX	039106
15b	CRANK-DRIVE	039235
15c	O-RING 1/2 ID X .139 W	048632
15d	O-RING 1-3/4 OD X .139 W	008904
16	PIN-COTTER-HAIRPIN-1/8DIA	044731
17	TUBE A.-PUMP FEED SS (8751)	X44666
*17a	TUBE A.-PUMP FEED L (8754)	X44662
*17b	TUBE A.-PUMP FEED R (8754)	X44664
18	O-RING-11/16 OD x .103 W RED	016132

\*NOT SHOWN

# Models 336/338/339 Three-Spout Door A.

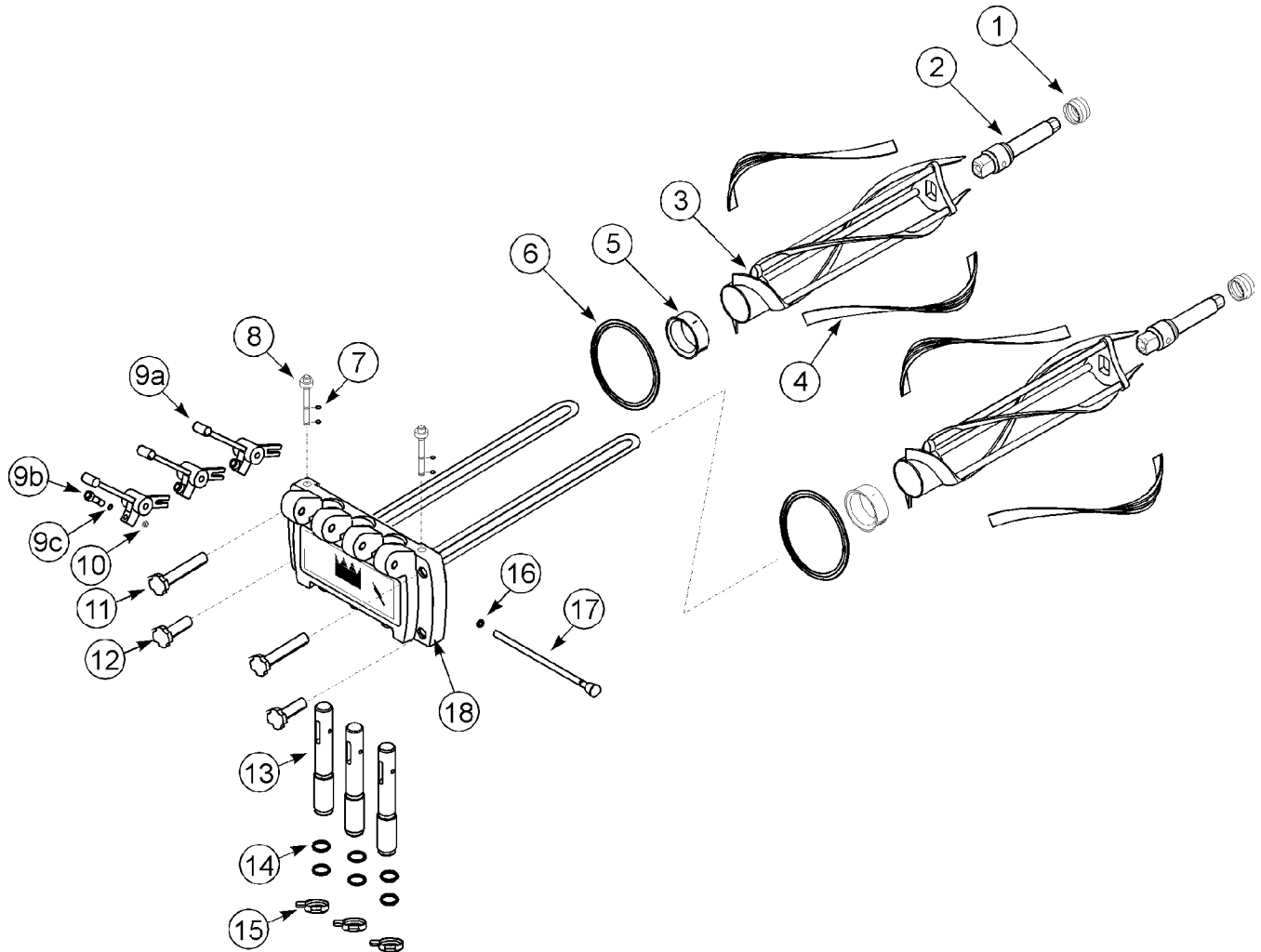

ITEM	DESCRIPTION	PART NO.
1	SEAL-DRIVE SHAFT	032560
2	SHAFT-BEATER	033235
3	BEATER A.-2.8 QT.	X35466
4	BLADE-SCRAPER-PLASTIC	035480
5	BEARING-FRONT	050216
6	GASKET-DOOR HT 4" DBL	048926
7	O-RING 3/8 OD x .070 W	016137
8	PLUG-PRIME	028805
9	HANDLE A.-ADJ. SS SCREW	X33687
9a	HANDLE-ADJ.	028804
9b	SCREW-ADJ. SS	033662

ITEM	DESCRIPTION	PART NO.
9c	O-RING 1/4 OD x .070 W	015872
10	NUT-5/16-24 18-8 SS JAM	029639-BLK
11	NUT-STUD LONG	034382
12	NUT-STUD SHORT	034383
13	VALVE A.-DRAW	X18303
14	O-RING 7/8 OD x .103 W	014402
15	CAP-DESIGN 1.010" ID-6 PT	014218
16	O-RING 5/16 OD x .070 W	016272
17	ROD A.-PIVOT	X20683
18	DOOR A.-3 SPOUT	X51532-15

# Models 750/751 One-Spout Beater Door A.

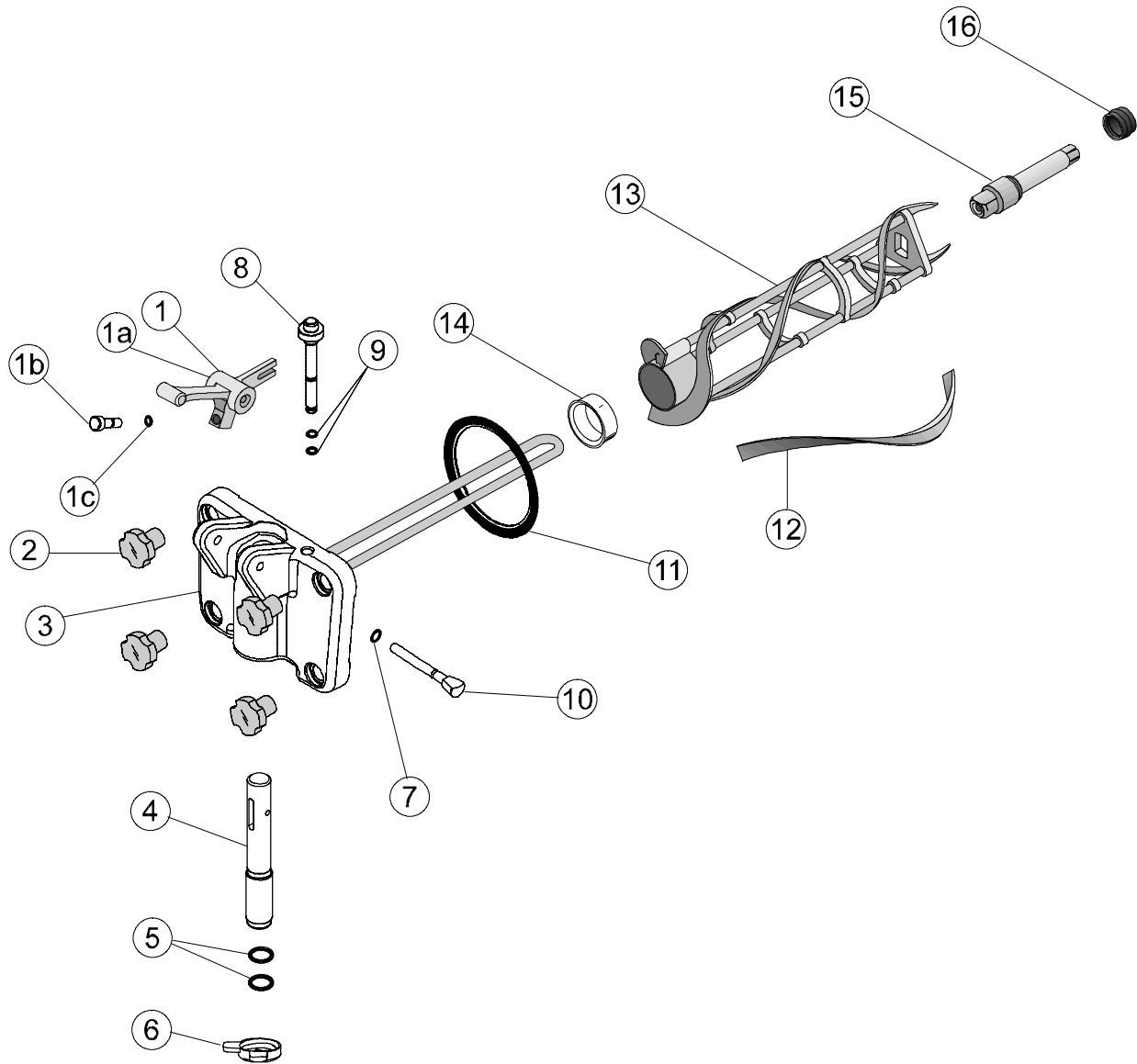

ITEM	DESCRIPTION	PART NO.
1	HANDLE A.-DRAW	X26996
1a	DRAW HANDLE	028804
1b	SCREW-ADJ.	026592
1c	O-RING 1/4 OD x .070 W	015872
2	NUT-STUD	021508
3	DOOR A. 1-SPOUT	X51531-10
4	VALVE A.-DRAW	X18303
5	O-RING 7/8 OD x .070 W	014402
6	CAP-DESIGN	014218
7	O-RING 5/16 OD x .070 W	016272

ITEM	DESCRIPTION	PART NO.
8	PLUG-PRIME	028805
9	O-RING 3/8 OD x .070 W	016137
10	PIN A.-PIVOT	X22820
11	GASKET-DOOR HT 4"	048926
12	BLADE-SCRAPER	035174
13	BEATER A.-HELICORE	X31761
14	BEARING-FRONT	050216
15	SHAFT-BEATER	032564
16	SEAL-DRIVE SHAFT	032560

# Models 754/774/794 Three-Spout Beater Door A.

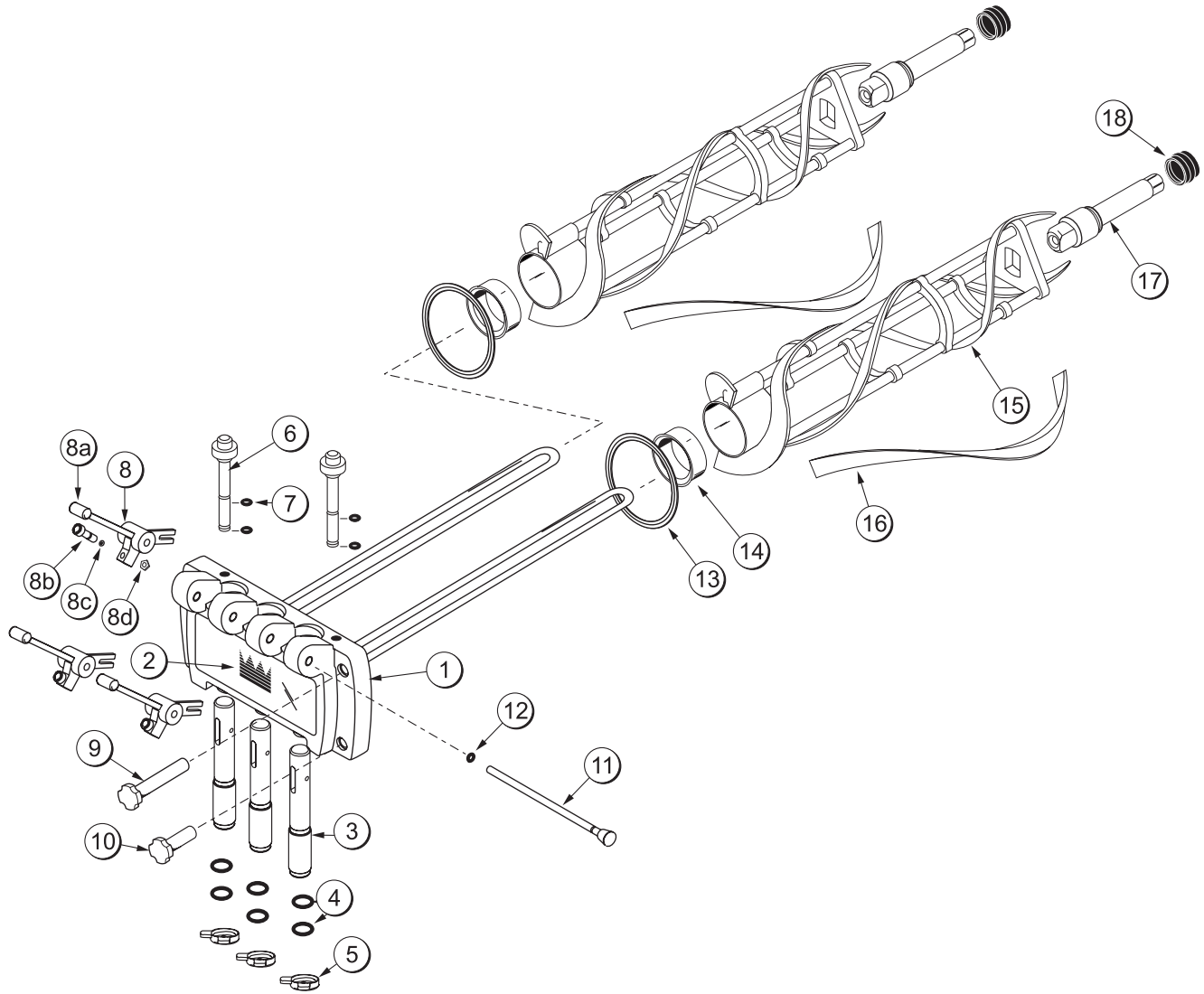

ITEM	DESCRIPTION	PART NO.
1	DOOR- 3-SPOUT	X51532-12
2	DECAL-DOOR	021521
3	VALVE A.- DRAW	X18303
4	O-RING 7/8OD X .070W	014402
5	CAP-DESIGN	014218
6	PLUG-PRIME	028805
7	O-RING-PRIME PLUG	016137
8	HANDLE A.- DRAW	X33687
8a	DRAW HANDLE	028804
8b	SCREW-ADJUST	033662
8c	O-RING 1/4OD X .070W	015872

ITEM	DESCRIPTION	PART NO.
8d	NUT-JAM	029639-BLK
9	NUT-STUD FLAT LONG	048928
10	NUT-STUD FLAT SHORT	048929
11	ROD A.- PIVOT	X20683
12	O-RING 5/16OD X .070W	016272
13	GASKET-DOOR HT 4"	048926
14	BEARING-FRONT	050216
15	BEATER A.- HELICORE	X31761
16	BLADE- SCRAPER	035174
17	SHAFT-BEATER	032564
18	SEAL-DRIVE SHAFT	032560

# Pump A.-Syrup 036623 (774)

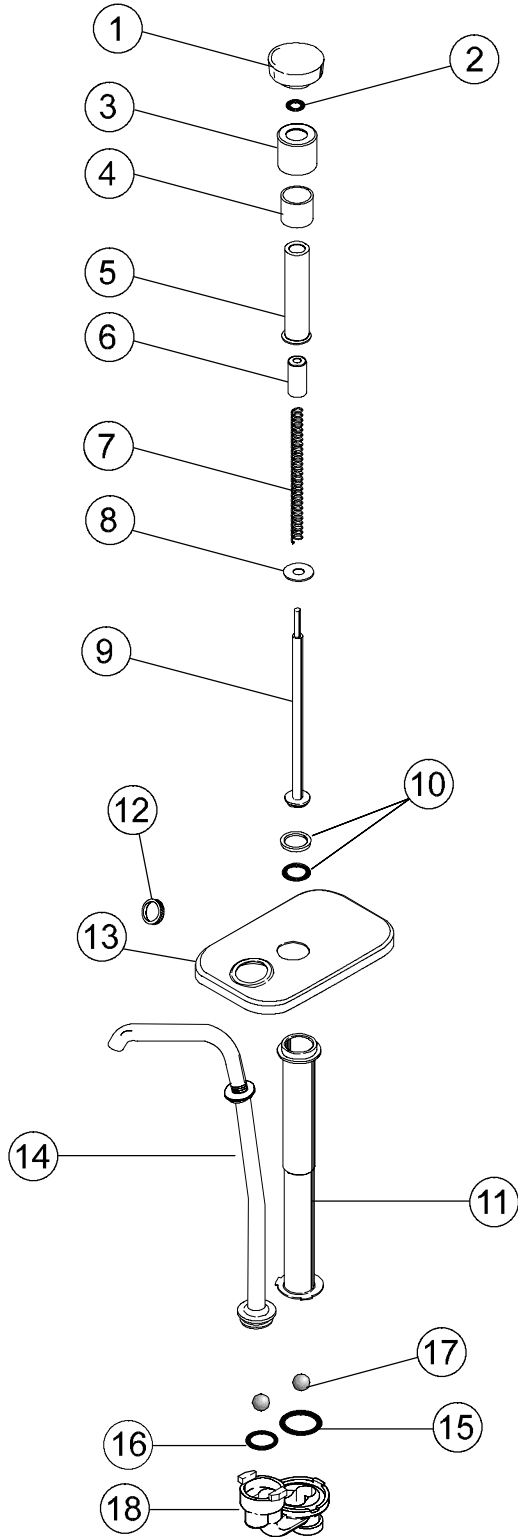

ITEM	DESCRIPTION	PART NO.
1	KNOB-PLUNGER (BROWN OR TAN)	032762-BRN / TAN
2	O-RING-9/16 OD x .103 W	016369
3	NUT-PLUNGER	036577
4	COLLAR-GAGING 1/2 OZ.	035514
5	TUBE-PLUNGER	032757
6	INSERT-PLUNGER	032758
7	SPRING-PLUNGER	032761
8	WASHER-NYLON	032760
9	PLUNGER	036578
10	SEAL ASSEMBLY INCLUDES 019330 O-RING	X33057
11	CYLINDER-SYRUP PUMP (SHALLOW JAR)	051065
12	NUT-SPOUT	036821
13	LID-PUMP	036822
14	TUBE A.-DISCHARGE	050912
15	O-RING-1-5/16 OD x .103 W	048149
16	O-RING-1" OD x .103 W	048148
17	BALL-1/2" 304 SS	032752
18	BODY-VALVE	048166

# Accessories

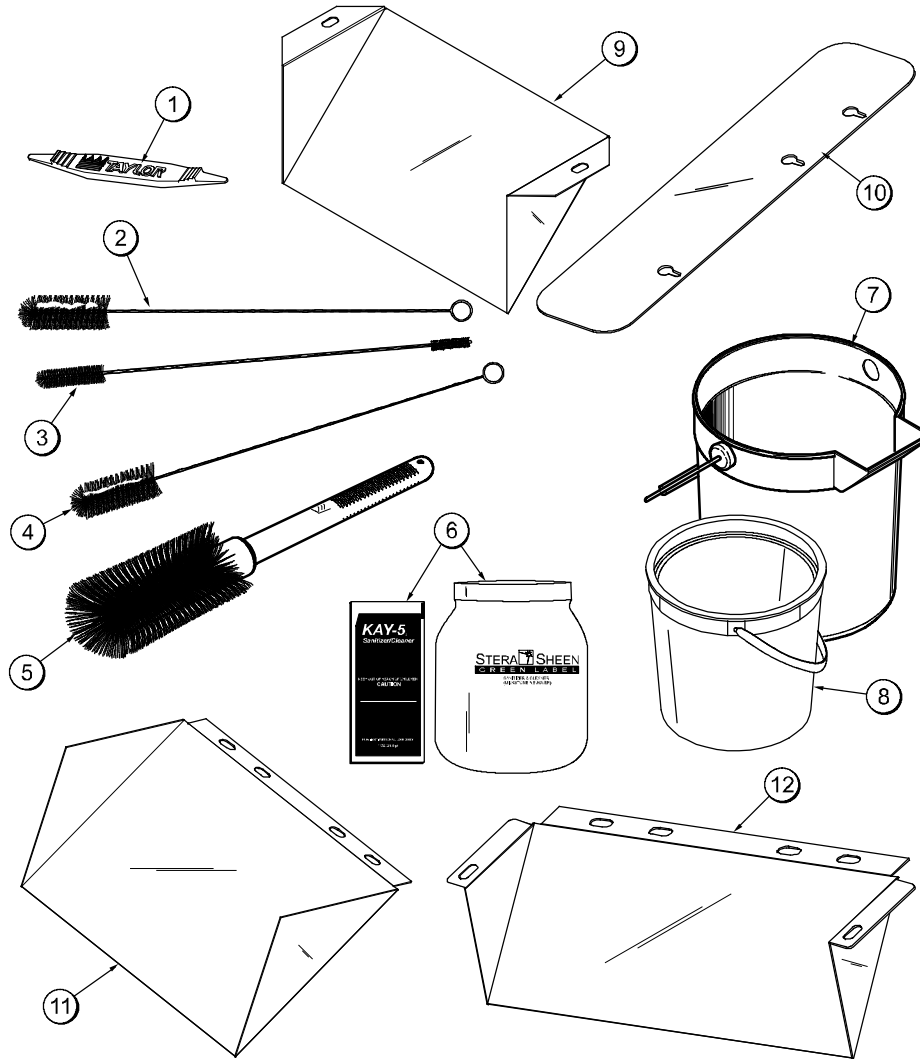

ITEM	DESCRIPTION	PART NO.
1	TOOL-O-RING REMOVAL-FREEZER	048260-WHT
2	BRUSH-REAR BRG 1IN.DX2IN.LGX	013071
3	BRUSH-DOUBLE ENDED-PUMP&FEED	013072
4	BRUSH-DRAW VALVE 1"ODX2"X17"	013073
5	BRUSH-MIX PUMP BODY-3"X7"WHITE	023316
6	SANITIZER KAY-5 125 PKTS	041082
	SANITIZER-STERA SHEEN	065293*

ITEM	DESCRIPTION	PART NO.
7	PAIL-MIX 10 QT. M336,339,751,754,774,794	013163
8	PAIL-6 QT. M338,750	023348
9	DEFLECTOR-BLOWER EXHAUST M794	047912
10	SKIRT-AIR FLOW M338	048489
11	DEFLECTOR-BLOWER EXHAUST M336	048345
12	DEFLECTOR-BLOWER EXHAUST M339,751,754,774	046586

\*MODEL 336 IS SHIPPED WITH STERA SHEEN.  
OTHER MODELS ARE SHIPPED WITH KAY-5.



# Parts List

DESCRIPTION	PART NUMBER	336 QTY.	338 QTY.	339 QTY.	WARR. CLASS	REMARKS
ACCUMULATOR-COPPER 2"DIA 10"	047062		1		103	
ADAPTOR A.-CASTER	X18915	4		4	103	
BEARING-FRONT	050216	2	2	2	000	
BEARING-REAR SHELL *NICK.PLATE	031324	2	2	2	000	
+GUIDE-DRIP SEAL	028992	2	2	2	000	
+NUT-BRASS BEARING	028991	2	2	2	000	
+WASHER-BEARING LOCK	012864	2	2	2	000	
BEATER A.-2.8QT-HELICORE	X35466	2	2	2	103	
+BLADE-SCRAPER-PLASTIC 13-1/4L	035480	4	4	4	000	
BELT-AX38	023873	4			000	
BELT-AX33	024396			4	000	
BELT-AX35	022848		4		000	208-230V 60HZ 1PH
BELT-AX36	022849		2		000	208-230V 60 HZ 3 PH (LEFT BEATER MOTOR)
BELT-AX 34	025729		2		000	208-230V 60 HZ 3 PH (RIGHT BEATER MOTOR)
BLOCK-TERMINAL 2P	039422	1	1	2	103	208-230V 60HZ 1PH
BLOCK-TERMINAL 3P	039423	1	1	2	103	208-230V 60HZ 3PH
BLOCK-TERMINAL 5 POLE	024329	1			103	
BLOWER A.-STANDARD OUTPUT	X53725-27	1		1	103	
CAPACITOR-RUN 7.5UF/370V	034749	1		1	103	
MOTOR-FAN 208-230V 50/60 HZ	053481-27	1		1	103	
SCREEN-BLOWER	053729	1		1	103	
BOARD-LOGIC-GEN 2.10-W/SEL DI	X36641SER2	2	2	2	212	208-230V 60HZ 1PH
BOARD-POWER-GEN 1 & 2	X32326-SER	2	2	2	212	
FUSE-.063A-250V-5X20MM-SLO BLO	051272	2	2	2	103	
BRUSH-REAR BRG 1IN.DX2IN.LGX14	013071	1	1	1	000	
BRUSH-DOUBLE ENDED-PUMP&FEED	013072	1	1	1	000	
BRUSH-DRAW VALVE 1"ODX2"X17"L	013073	1	1	1	000	
BRUSH-MIX PUMP BODY-3"X7"WHITE	023316	1	1	1	000	
CABLE A.-2 COND-12 IN-PUSH ON	X38322	1			103	
CABLE A.-2 COND-24 IN-PUSH ON	X34464		1	1	103	
CABLE-RIBBON-PWR/RELAY-60 IN	032445	2			103	
CABLE-RIBBON-14C-30"L-DIP/DIL	035683		1		103	

+ Available Separately

090416

DESCRIPTION	PART NUMBER	336 QTY.	338 QTY.	339 QTY.	WARR. CLASS	REMARKS
CABLE-RIBBON-14C-40"L-DIP/DIL	042931		1		103	
CABLE-RIBBON-PWR/RELAY-66 IN	042599			2	103	
CAP-DESIGN-1.010"ID-6 POINT	014218	3	3	3	000	
CASTER-SWV 5/8 STEM 4IN WHEEL	018794	4		4	103	
COMPRESSOR CS17K6E-PFV-238 - EMERSON	052397-27E	1	1		512	208-230V 60HZ 1PH - J9012206 & UP REPLACES 052397-27
+CAPACITOR-RUN 35UF/440V	048132	1	1		103	
+CAPACITOR-START 189-227UF/25	053106	1	1		103	
+RELAY-START-COMPRESSOR	051957-27	1	1		103	
+KIT-MOUNTING-COMPRESSOR	052197	1			000	
COMPRESSOR CS14K6E-PFV	052396-27			2	512	208-230V 60HZ 1PH
+CAPACITOR-RUN 35UF/370V	029439			2	103	
+CAPACITOR-START 189-227UF/250	053106			2	103	
+RELAY-START-COMPRESSOR	052401-27			2	103	
COMPRESSOR CS18K6E-TF5-238	052397-33	1	1		512	208-230V 60HZ 3PH
COMPRESSOR CS14K6E-TF5-238	052396-33			2	512	208-230V 60HZ 3PH
COMPRESSOR TL3G-R134A - DANFOSS	047701-27	1	1	1	512	SHR
+CAPACITOR-START-60UF-220/275V	047703	1	1	1	103	
+KIT-MOUNTING-COMPRESSOR	047704	1	1	1	103	
+RELAY-START-COMPRESSOR-TL3	047702-27	1	1	1	103	
+COVER-TERMINAL	047739	1	1	1	103	
CONDENSER-AC-7X6X1.25-2 ROW	027155	1	1	1	103	SHR
CONDENSER-AC 12LX18HX3.12T-5RW	053502-1	1			103	K302 & UP REPLACES 055813-1
CONDENSER-AC-19X14X2.5-4ROW	048623		1		103	
CONDENSER-AC 12LX18HX3.12T-5RW	055813-1			1	103	
CONDENSER-AC 12LX18HX3.12T-5RW	055813-2			1	103	
COUPLING-DRIVE 3/4 HEX X 1-7/8	012721	2	2	2	103	
+SCREW-5/16-18 X 5/16 ALLEN SET	042511	4	4	4	000	
COVER A.-HOPPER *162-168*	X37963-SER	1			103	
+GASKET-HOPPER COVER-8QT	037042	1			000	
+KNOB-MIX COVER	025429	1			103	
COVER A.-HOPPER-STD	X38458-SER		2	2	103	
+GASKET-HOPPER COVER-20 QT	038474		1	1	000	

+ Available Separately

DESCRIPTION	PART NUMBER	336 QTY.	338 QTY.	339 QTY.	WARR. CLASS	REMARKS
+KNOB-MIX COVER	025429		2	2	103	
DECAL-DEC-TAYLOR 336-SOFTECH	038337	1			000	
DECAL-DEC-TAYLOR-SS	032919		1	1	000	
DECAL-INST-CLN HPR	019029	1	1	1	000	
DECAL-TROUBLESHOOTING	038374	1	1	1	000	
DEFLECTOR-BLOWER EXHAUST	048345	1			103	
DEFLECTOR-BLOWER EXHAUST	047912			1	103	
DIAGRAM-WIRING	038333	1			000	208-230V 60HZ 1PH
DIAGRAM-WIRING *336*	038333-33	1			000	208-230V 60HZ 3PH
DIAGRAM-WIRING	051624-27		1		000	208-230V 60HZ 1PH
DIAGRAM-WIRING *338*	051624-33		1		000	208-230V 60HZ 3PH
DIAGRAM-WIRING	046585-27			1	000	208-230V 60HZ 1PH
DIAGRAM-WIRING *754-774*8754	046585-33			1	000	208-230V 60HZ 3PH
DOOR A.-3 SPOUT	X51532-15	1	1	1	103	J5080000/U/P
+BEARING-FRONT	050216	2	2	2	000	
+GASKET-DOOR HT 4"-DOUBLE	048926	2	2	2	000	
+HANDLE A.-DRAW ADJUSTABLE	X55096	3	3	3	103	
+SCREW-ADJUSTMENT-5/16-24	055092	3	3	3	000	
+NUT-5/16-24 FINISHED HEX JAM	029639-BLK	3	3	3	000	
+O-RING-1/4 OD X .070W 50 DUR	015872	3	3	3	000	
+PLUG-PRIME	028805	2	2	2	103	
+O-RING-3/8 OD X .070W	016137	4	4	4	000	
+ROD A.-PIVOT	X20683	1	1	1	103	
+O-RING-5/16 OD X .070W	016272	1	1	1	000	
+VALVE A.-DRAW	X18303	3	3	3	103	J7060000 - REPLACED X45380 CENTER
+O-RING-7/8 OD X .103W	014402	6	6	6	000	
DRYER-CAP. TUBE-HP62/R134A	047699	1	1	1	000	SHR
DRYER-FILTER-HP62-3/8 X 1/4S	048901	1	1	2	000	
DVD-OPS-TRAIN-SS-SOFTECH	038047-DVD	1	1	1	000	
EYELET-RESET BUTTON	013739	2	2	2	000	
FASTENER-CLIP 1/4-20 U-TYPE	045865	8		8	000	BASE PAN/PANELS
FILTER-AIR-18.00LX14.25HX.70W	052779-4	1			000	
+GUIDE-FILTER *336*	054497	1			103	

+ Available Separately

DESCRIPTION	PART NUMBER	336 QTY.	338 QTY.	339 QTY.	WARR. CLASS	REMARKS
FILTER-AIR-18.00LX13.50HX.70W	052779-3			1	000	
+GUIDE-FILTER*444*632S*(8)754AC	053784			1	103	
GEAR A.*REDUCER 4.21:1 SERVICE	021286-SER	2	2	2	212	
GUARD-FAN	028534-1		1		103	
GUIDE A.-DRIP PAN	X27554	1			103	
GUIDE A.-DRIP PAN	X51567		1		103	
GUIDE A.-DRIP PAN	X28699			1	103	
HOOD	041026	1			103	
HOOD	042866		1		103	
HOOD	035434			1	103	
KIT A.-MOTOR-FAN	X62253-27	1	1	1	103	
KIT A.-TUNE UP-3 SPOUT-NON HT	X49463-6	1			000	
BEARING-FRONT	050216	2			000	
CAP-DESIGN-1.010"ID-6 POINT	014218	3			000	
GASKET-DOOR HT 4"-DOUBLE	048926	2			000	
O-RING-.563 OD X .070W-#013	043758	8			000	
O-RING-3/8 OD X .070W	016137	6			000	
O-RING-5/16 OD X .070W	016272	1			000	
O-RING-7/8 OD X .BW	014402	6			000	
SEAL-DRAW VALVE	034698	1			000	
SEAL-DRIVE SHAFT	032560	2			000	
TOOL- O-RING REMOVAL	048260-WHT	1			000	
KIT A.-TUNE UP-3 SPOUT-NON HT	X49463-4		1	1	000	
BEARING-FRONT	050216		2	2	000	
CAP-DESIGN-1.010"ID-6 POINT	014218		3	3	000	
GASKET-DOOR HT 4"-DOUBLE	048926		2	2	000	
O-RING-.643 OD X .077W	018572		8	8	000	
O-RING-3/8 OD X .070W	016137		6	6	000	
O-RING-5/16 OD X .070W	016272		1	1	000	
O-RING-7/8 OD X .103W	014402		6	6	000	
SEAL-DRAW VALVE	034698		1	1	000	
SEAL-DRIVE SHAFT	032560		2	2	000	
TOOL-O-RING REMOVAL	048260-WHT		1	1	000	

+ Available Separately

DESCRIPTION	PART NUMBER	336 QTY.	338 QTY.	339 QTY.	WARR. CLASS	REMARKS
LABEL-DOOR-MOVE PART	032749	1	1	1	000	
LABEL-WARN-COVER	051433	5	5	6	000	
LABEL-SWITCH-POWER *OFF/ON*	052632	1	1	1	000	J8080000/UP (ON POSITION ON RIGHT SIDE)
LABEL-3PH MTR PROT/1PH C-ENG/S	025949	1	1	1	000	208-230V 60HZ 3PH
LABEL-CK MTR ROTATE-CW-ENG/SPN	020090	1	1	1	000	208-230V 60HZ 3PH
LEG-4" SS-W/ORING	013458		4		103	
LOUVER-SIDE-TOP *772* 430 SS	051191	2	1	2	103	MODEL 338 - LEFT SIDE
LUBRICANT-TAYLOR 4 OZ.	047518	1	1	1	000	
MAN-OPER 300 SERIES SOFTECH	036029-M	1	1	1	000	
MOTOR-1.0 HP	013102-27	2	2	2	212	208-230V 60HZ 1PH
MOTOR-1.0 HP	013102-33	2	2	2	212	208-230V 60HZ 3PH
MOTOR-FAN 95.3 CFM 2700 RPM	062253-27	*	*	*		SEE - KIT A.-MOTOR FAN
MOTOR-FAN 50W W/GROUNDWIRE	029770-27		1		103	208-230V 60HZ 3PH
+FAN-5 BLADE 12" PUSH 22DEG	049009		1		103	
NUT-STUD *460-664-754-56*LONG	034382	2	2	2	103	
NUT-STUD *460-664-754-56*SHORT	034383	2	2	2	103	
ORIFICE	022465-100	2	2	2	103	
+O-RING-3/8 OD X .070W	016137	2	2	2	000	
PAIL-MIX 10 QT.	013163	1		1	000	
PAIL-MIX 6 QT.	023348		1		000	
PAN A.-DRIP - 17-1/4" LONG	027504	1		1	103	SIDE PANEL MOUNT
PAN A.-DRIP - 15-1/8" LONG	X51601		1		103	FRONT PANEL MOUNT
PAN A.-DRIP HINGED	X41844		1		103	INTERNAL MOUNT
PANEL A.-FRONT	X42821-SP1	1			103	
PANEL A.-LOWER SIDE	X24424-SER	1		2	103	RIGHT
PANEL A.-SIDE LWR FLT *336AC*L	X54503-SER	1			103	
PANEL-REAR	029816	1			103	
PANEL-SERVICE	042824	1			103	
PANEL-UPPER SIDE LEFT	028740	1		1	103	
PANEL-UPPER SIDE RIGHT	028741	1		1	103	
PANEL A.-FRONT	X51590		1		103	
PANEL A.-SIDE LEFT	X51596-SER		1		103	
PANEL A.-SIDE RIGHT	X48596		1		103	UPPER

+ Available Separately

DESCRIPTION	PART NUMBER	336 QTY.	338 QTY.	339 QTY.	WARR. CLASS	REMARKS
PANEL-SIDE-RIGHT	048487		1		103	LOWER
PANEL-REAR	051600		1		103	
PANEL A.-FRONT	X32956			1	103	
PANEL-REAR*444*632S*(8)754*AC	053782			1	103	
PANEL-SERVICE	024439			1	103	
PLATE-DEC-336*	038081	1			103	
PLATE-DEC-754-755	032961		1	1	103	
PLUG-DRIP TRAY HOLE	029595	1		1	000	
PROBE A.-MIX *SQUARE*	X30922	2	2	2	103	
PROBE A.-THERMISTOR - BARREL	X31602	2	2	2	103	
PROBE A.-THERMISTOR/RESISTOR - HOPPER	X50717	1	1	1	103	336-J8112694/JP, 339-J6090000/JP
PROBE A.-THERMISTOR - HOPPER	X34466	*		*	103	336-PRIOR J8112694, 339-PRIOR J6090000
PULLEY-2AK20 X 5/8 BORE	034238	2	2	2	103	BEATER MOTOR
PULLEY-2AK64-5/8 BORE	039695	2	2	2	103	GEAR
RECEPTACLE A.-QUICK CONNECT	X33321	2	2	2	103	DRAW SWITCH
RELAY-3 POLE-20A-208/240 50/60	012725-33	1	1	2	103	COMPRESSOR
RELAY-SPDT-30 A-240 V	032607-27	1		1	103	BLOWER MOTOR
SANITIZER KAY-5 125 PACKETS	041082		*	*	000	
SANITIZER-STERA SHEEN-GREEN	055492	*			000	100/2OZ. PACKETS/CS FOR RESALE
SANITIZER-STERA SHEEN GR.	010425	*			000	64 OZ JAR
SHAFT-BEATER	033235	2	2	2	103	
+SEAL-DRIVE SHAFT	032560	2	2	2	000	
SHELL A.-INSULATED	X52982-SP	1			512	
+STUD-NOSE CONE	022822	4			103	
SHELL A.-INSULATED	X50770-SER		1	1	512	339-J6090000/JP
+STUD-NOSE CONE	022822		4	4	103	
SHIELD-SPLASH *5454-8-752-336*	022765	1			103	
SHIELD-SPLASH 23 L	022766		1	1	103	
SKIRT-AIR FLOW	048489		1		103	
+COLLAR-HOLDING	019481		3		103	
+SCREW-HOLDING COLLAR	001086		3		000	
STARTER-1 PHASE-4.5 TO 7 A	041950-27K	2	2	2	103	208-230V 60HZ 1PH

+ Available Separately

DESCRIPTION	PART NUMBER	336 QTY.	338 QTY.	339 QTY.	WARR. CLASS	REMARKS
OVERLOAD-THERMAL	047150-27K	2	2	2	103	
STARTER-3 PHASE-3 TO 5 AM	041950-33J	2	2	2	103	208-230V 60HZ 3PH
OVERLOAD-THERMAL	047150-33J	2	2	2	103	
SWITCH A.-DRAW *336*SELF CLOSE	X43417-SER	1			103	
ARM-SWITCH-DRAW-LEFT	038649	1			103	
ARM-SWITCH-DRAW-RIGHT	038650	1			103	
BRACKET A.-SPRING RETURN	X38257	1			103	
E-RING 1/4	032190	4			000	
PIN-PIVOT-DRAW SWITCH	038484	1			103	
SPRING-EXTENSION.375X.045X1.00	038922	2			103	
SPRING-RETURN-LEFT-TWIN TWIST	038923	1			103	
SPRING-RETURN-RIGHT	038924	1			103	
SWITCH A.-DRAW-TWIN TWIST	X39269	1			103	
BRACKET-DRAW SWITCH	039264	1			103	
SWITCH-LEVER-SPDT-11A-125	039252	2			103	
SWITCH A.-DRAW *SELF CLOSING*	X38547		1	1	103	
ARM-SWITCH-DRAW-LEFT	038649		1	1	103	
ARM-SWITCH-DRAW-RIGHT	038650		1	1	103	
BRACKET A.-SPRING RETURN	X38257		1	1	103	
BRACKET A.-SWITCH *338-39-754	X38252		1	1	103	
E-RING 1/4	032190		4	4	000	
PIN-PIVOT-DRAW SWITCH	038484		1	1	103	
ROD-SPRING RETAINER	038254		1	1	103	
SCREW-8-32X3/8 HEX HD TYPE 23	039267		2	2	000	
SPRING-EXTENSION.375X.045X1.00	038922		2	2	103	
SPRING-RETURN-LEFT-TWIN TWIST	038923		1	1	103	
SPRING-RETURN-RIGHT-TWIN	038924		1	1	103	
SWITCH A.-DRAW-TWIN TWIST	X39269		1	1	103	
BRACKET-DRAW SWITCH-TWIN	039264		1	1	103	
SCREW-4-40 X1/2" TAPTITE PAN	042604		4	4	000	
SWITCH-LEVER-SPDT-11A-125	039252		2	2	103	
SWITCH-PRESSURE 405 PSI-SOLDER	052663	1	1	2	103	
SWITCH-TOGGLE-4PDT*ON-NONE-ON	037394	1	1	1	103	

+ Available Separately

DESCRIPTION	PART NUMBER	336 QTY.	338 QTY.	339 QTY.	WARR. CLASS	REMARKS
TRAY-DRIP 16-7/8L X 5-1/8	020157	1			103	
TRAY-DRIP 22-7/8L X 5-1/8W	014533		1	1	103	
TRIM-FRONT	051595		1		103	
TRIM-REAR CORNER LEFT	013761	1		1	103	
TRIM-REAR CORNER RIGHT	013663	1		1	103	
TRIM-REAR CORNER LEFT	044280		1		103	
TRIM-REAR CORNER RIGHT	044281		1		103	
TUBE-FEED 5/32 DIA. HOLE	043461-2	2			103	
+O-RING-.563 OD X .070W-#013	043758	8			000	
TUBE A-FEED-SS-5/32 HOLE DIA	X29429-2		2	2	103	
+O-RING-.643 OD X .077W	018572		8	8	000	
VALVE-ACCESS-1/4MFL X 3/8ODSDR	053565	2	2	4	103	
VALVE-ACCESS-1/4 MFLX1/4 S-90	047016	1	1	2	103	
VALVE-ACCESS-1/4FL X 1/4SOLDER	044404	1	1	1	103	
VALVE-EPR 1/4S	022665	1	1	1	103	
VALVE-EXP-AUTO-1/4S X1/4 FPT	046365	2	2	2	103	
+BOOT-EXPANSION VALVE	050900	2	2	2	000	J7010000/JP
VALVE-SOLENOID 7/16 ORF 5/8ODF	048626-27	2	2		103	SUCTION
VALVE-SOLENOID 7/64ORF X 1/4S	043449-27	2	2		103	LIQUID
WASHER-PLASTIC PIVOT	013808	4	4	4	000	UPPER SIDE PANEL

DESCRIPTION	PART NUMBER	336 QTY.	338 QTY.	339 QTY.	WARR. CLASS	REMARKS
WATER COOLED						
BLOWER-100 CFM	012796-27	1		1	103	
+GUARD-BLOWER	022505	1		1	103	
BRACKET-VALVE-WATER MOUNT	038777	1	1		103	038778 SCREW-8-32X5/16 PHIL PAN
CLAMP-HOSE 7/8-EAR-ZINC PLATE	043891	4		8	000	
CONDENSER-W/C COAX	047540	1			103	
CONDENSER-WC-SPIRAL 11-1/2 OD	049309		1		103	
CONDENSER-W/C COAX	048287			2	103	
COUPLING-3/8 NPT BLACK PI	010878	3			103	
HOSE-RUBBER 1/2 ID X 7/8 OD	R50200	5'	5'	10'	000	

+ Available Separately



DESCRIPTION	PART NUMBER	336 QTY.	338 QTY.	339 QTY.	WARR. CLASS	REMARKS
+CLAMP-HOSE 3/4 ID CONST TENSN	067113	4	4		000	NEW STYLE AUTOMOTIVE
+CLAMP-HOSE 7/8-EAR-ZINC PLATE	043891			8	000	OLD STYLE
MOTOR-FAN-25W 230V	015184-27		1		103	
+FAN-5 BLADE 10 " PUSH	013043		1		103	
+BRACKET-FAN *337*	045652		1		103	
OUTLET A.-TEE	X25900			1	103	
PANEL-REAR	017563			1	103	
PIPE TEE 3/8-WATER VALVE-	032953			1	103	
SWITCH-PRESSURE 350PSI-SOLDER	048231	1	1	2	103	
VALVE-WATER 3/8 REG/HEAD PRESS	046686	1	1	2	103	
<b>50Hz</b>						
BELT-AX33	024396			4	000	
BELT-AX34	025729		2		000	220-240V 50HZ 3PH
BELT-AX36	022849		2		000	220-240V 50HZ 3PH
BELT-AX39	023874	4			000	220-240V 50HZ 1PH /380-450V 60H 3N~/BEATER MTR
BLOCK-TERMINAL 2 POLE	039421			2	103	220-240V/50/1 / 380-450V 60H 3N~
BLOCK-TERMINAL 2P .25 SPA	051644	1			103	220-240V 50HZ 1PH
BLOCK-TERMINAL 2P L1,L2	039422		2		103	
BLOCK-TERMINAL 2P L1,N	039421	1		2	103	220-240V 50HZ 1PH
BLOCK-TERMINAL 3P L1,L2,L	039423	1	1	2	103	220-240V 50HZ 3PH / 460V 60H 3PH
BLOCK-TERMINAL 4P L1,L2,L	039424		1		103	380-415V 50HZ 3N~
BLOCK-TERMINAL-7 POLE GREEN	024156	1	1	2	103	200V 50/60HZ 3PH / 220-240V 50HZ 1PH/3PH / 380-450V 60HP 3N~ / 460V 60HZ 3PH
BLOCK-TERMINAL-2 POLE	039422	2			103	
CABLE-RIBBON-PWR/RELAY-60	032445			2	103	220-240V 50HZ 3PH /220-240V 50HZ 1PH /380-450V 60HP 3N~
COMPRESSOR CS14K6E-TF5-23	052396-33			1	512	220-240V 50HZ 3PH / 200V 50/60HZ 3PH
COMPRESSOR CS14K6E-PFJ-23	052396-40			2	512	220-240V 50HZ 1PH
+CAPACITOR-RUN 35UF/370V	029439			2	103	220-240V 50HZ 1PH
+CAPACITOR-START 145-175UF	012901			2	103	220-240V 50HZ 1PH
+RELAY-START-COMPRESSOR	051957-12			2	103	220-240V 50HZ 1PH
COMPRESSOR CS18K6E-TF5-23	052397-33	1	1		512	220-240V 50HZ 3PH / 380-415V 50HZ 3N~

+ Available Separately

DESCRIPTION	PART NUMBER	336 QTY.	338 QTY.	339 QTY.	WARR. CLASS	REMARKS
COMPRESSOR - COPELAND	052397-40	1			512	220-240V 50HZ 1PH
+CAPACITOR-RUN-45UF-370V	052400	1			103	220-240V 50HZ 1 PH - COPELAND - J9012206/UP
+CAPACITOR-START	052399	1			103	220-240V 50HZ 1 PH - COPELAND - J9012206/UP
+RELAY-START-COMPRESSOR	052401-27	1			103	220-240V 50HZ 1 PH - COPELAND - J9012206/UP
COMPRESSOR CS14K6E-TFD-23	052396-58			2	512	380-415V 50HZ 3N~
COMPRESSOR CS18K6E-TFD-23	052397-58	1			512	460V 60HZ 3PH
DIAGRAM-WIRING *336*	038333-39	1			000	200V 50/60HZ 3PH
DIAGRAM-WIRING	038333-34	1			000	220-240V 50HZ 1PH
DIAGRAM-WIRING *336*GEN I	038333-62	1			000	380-415V 50HZ 3N~
DIAGRAM-WIRING *336*	038333-63	1			000	460V 60HZ 3PH
DIAGRAM-WIRING *338*	051624-35		1		000	220-240V 50HZ 3PH
DIAGRAM-WIRING	051624-40		1		000	220-240V 50HZ 1PH
DIAGRAM-WIRING *754-774*8	046585-35			1	000	220-240V 50HZ 3PH
DIAGRAM-WIRING	046585-34			1	000	220-240V 50HZ 1PH
DIAGRAM-WIRING *754-774*8	046585-39			1	000	220V 50/60HZ 3PH
DIAGRAM-WIRING *754-774*8	046585-62			1	000	380-415V 50HZ 3N~
DVD-OPS-TRAIN-SS-SOFTTECH	038047-DVD	1			000	
LABEL-3PH MTR PROT/1PH C-ENG/S	025949	1	1	1	000	220-240V 50HZ 3PH / 460V 60HZ 3PH
LABEL-CK MTR ROTATE-CW-ENG/SPN	020090	1	1	1	000	200V 50/60HZ 3PH / 460V 60HZ 3PH
MOTOR-1.0 HP	013102-33	2	2	2	212	200V 50/60HZ 3PH / 460V 60HZ 3PH
MOTOR-1.0 HP	013102-34	2		2	212	220-240V 50HZ 1PH
MOTOR-1.0 HP	013102-35	2	2	2	212	220-240V 50HZ 3PH / 380-415V 50HZ 3N~
PULLEY 2AK25 X .625	021076	2	2	2	103	220-240V 50HZ 1PH/3PH / 380-450V 60PH 3N-BEATER MOTOR
RELAY-3 POLE-20A-208/240	012725-33	1			103	220-240V 50HZ 1PH/3PH
STARTER-3 PHASE-2.0 TO 3.	041950-33H		2	2	103	220-240V 50HZ 3PH
OVERLOAD-THERMAL-3P-2.0/3.3A	047150-33H		2	2	103	220-240V 50HZ 3PH
STARTER-3 PH 1.4 TO 2.3A	041950-33G	2	2	2	103	380-415V 50HZ 3N~ / 460V 60HZ 3PH
OVERLOAD-THERMAL	047150-33G	2	2	2	103	
TRANS.-CONT.-1 KVA	021093	1		1	103	460V 60HZ 3PH

+ Available Separately

HP62 Refrigerant: 750 - J6110454, 751 - J6080596, 754 - J6080465, 774 - J6092382, and 794 - J4094101/up

DESCRIPTION	PART NUMBER	750 QTY.	751 QTY.	754 QTY.	774 QTY.	794 QTY.	WARR. CLASS	REMARKS	PARTS UPDATE
ADAPTOR A-CASTER	X18915		4	4	4	4	103		
BEARING-FRONT	050216	1	1	2	2	2	000		
BEARING-REAR SHELL	031324	1	1	2	2	2	000		
+GUIDE-DRIP SEAL	028992	1	1	2	2	2	000		
+NUT-BRASS BEARING	028991	1	1	2	2	2	000		
+WASHER-BEARING LOCK	012864	1	1	2	2	2	000		
BEATER ASSEMBLY	X31761	1	1	2	2	2	103		
+BLADE-SCRAPER	035174	2	2	4	4	4	000		
BELT-AX40	023875	2					000		
BELT-AX35	022848		2	4			000		
BELT-AX34	025729				4		000		
BELT-AX31	041575					4	000		
BLOCK-TERMINAL-2 P	039422	1	1	2	2	2	103	SINGLE PHASE	
BLOCK-TERMINAL-3 P	039423	1	1	2	2	2	103	THREE PHASE	
SCREW-TERMINAL BLOCK	039420	2	2	4	4	4	000		
BLOWER ASSEMBLY	X47833-27		1	1	1	1	103		
CAPACITOR-RUN	033047		1	1	1	1	103		
BOOT-CAPACITOR	031314		1	1	1	1	000		
HOUSING A-wwHEEL	X30160		1	1	1	1	103		
MOTOR-BLOWER	046536-27		1	1	1	1	103		
BOARD-LOGIC	X36641SER1	1	1	2	2	2	212		
BOARD-POWER	X32326-SER	1	1	2	2	2	212		
FUSE-SLO BLO	051272	1	1	2	2	2	103		
BRUSH-BLACK (1" X 2")	013071	1	1	1	1	1	000		
BRUSH-DOUBLE END	013072	1	1	1	1	1	000		
BRUSH-WHITE (1" X 2")	013073	1	1	1	1	1	000		
BRUSH-WHITE (3" X 7")	023316	1	1	1	1	1	000		
CABLE-RIBBON	032445	1	1	2			103		
CABLE-RIBBON	042599				2		103		
CAP-DESIGN	014218	1	1	3	3	3	000		
CAPACITOR-RUN	051785	1					103	FAN MOTOR - 051744-27	136

+ Available Separately

DESCRIPTION	PART NUMBER	750 QTY.	751 QTY.	754 QTY.	774 QTY.	794 QTY.	WARR. CLASS	REMARKS	PARTS UPDATE
CAPACITOR-RUN	019624	1					103	FAN MOTOR - 041401-27	136
CASTER-SWIVEL	018794		4	4	4	4	103		
COMPRESSOR - COPELAND	051958-27	1					512	J8108583/UP- 230-60-1	136
COMPRESSOR - COPELAND	051958-58	1					512	J8108583/UP- 220-240/380-415/50/3	136
LINE A-ACCESS COMPRESSOR	X42513	1					130	COPELAND	136
CAPACITOR-RUN	012906	1					103	230-60-1 - J8108583/UP	136
CAPACITOR-START	033044-1	1					103	230-60-1 - J8108583/UP	136
RELAY-START COMPRESSOR	051957-27	1					103	230-60-1 - J8108583/UP	136
COMPRESSOR - BRISTOL	048727-	1					512	PRIOR TO J8108583	112/136
CAPACITOR-RUN	023606	1					103	230-60-1 - PRIOR TO J8108583	136
CAPACITOR-START	031790	1					103	230-60-1 - PRIOR TO J8108583	136
RELAY-START	048765	1					103	230-60-1 - PRIOR TO J8108583	136
COMPRESSOR - BRISTOL	048259-		1	2	2	2	512		
CAPACITOR-RUN	012906		1	2	2	2	103	230-60-1	
CAPACITOR-START	031790		1	2	2	2	103	230-60-1	
RELAY-START	038145		1	2	2	2	103	230-60-1	
COMPRESSOR - TECUMSEH	047519-					2	512		
CAPACITOR-RUN	048132					2	103		
CAPACITOR-START	036048					2	103		
RELAY-START	036047					2	103		
COMPRESSOR-AUXILIARY	047701-27	1	1	1	1	1	512		
CAPACITOR-START	047703	1	1	1	1	1	103		
RELAY-START	047702-27	1	1	1	1	1	103		
COVER-TERMINAL	047739	1	1	1	1	1	103		
CONDENSER-AUXILIARY	027155	1	1	1	1	1	103		
CONDENSER-MAIN	046558	1					103		
CONDENSER-MAIN	048233		1	2	2	2	103		
COUPLING-DRIVE	012721	1	1	2	2	2	103		
COVER A.-MIX HOPPER	X38458-SER	1	1	2	2	2	103		
+GASKET-MIX HOPPER	038375	1	1				000		

+ Available Separately

DESCRIPTION	PART NUMBER	750 QTY.	751 QTY.	754 QTY.	774 QTY.	794 QTY.	WARR. CLASS	REMARKS	PARTS UPDATE
+GASKET-MIX HOPPER	038474			1	1		000		
KNOB-MIX HOPPER	025429	1	1	2	2		103		
COVER-MIX HOPPER	041682-GRY					2	103		
DECAL-DECORATIVE SOFTECH	033230	1	1				000		
DECAL-DECORATIVE SOFTECH	032919			1	1		000		
DECAL-DECORATIVE SOFTECH	045812					1	000		
DECAL-HEATER SWITCH	036551				1		000	"ON-OFF"	
DECAL-CLEAN & SANITIZE	019029	1	1	1	1	1	000		
DECAL-POWER SWITCH - ON/OFF (OLD)	32484			1		1	000	PRIOR TO J8080000 (NEW - SEE LABEL)	132
DECAL-POWER SWITCH - ON/OFF	032484	1	1		1		000		
DECAL-TROUBLESHOOTING	038374	1	1	1	1	1	000		
DECAL-WARNING	036529	3	3	3	3	3	000		
DEFLECTOR-BLOWER EXHAUST	046586		1	1	1		103		
DEFLECTOR-BLOWER EXHAUST	047912					1	103		
DIAGRAM-WIRING	052613-	1					000	J8108583/JP (COPELAND)	136
DIAGRAM-WIRING	050318-	1	1				000	750 - PRIOR TO J8108583	136
DIAGRAM-WIRING	046585-			1	1		000		
DIAGRAM-WIRING	048199-					1	000		
DOOR A.-FREEZER	X51531-10	1	1				103		
+BEARING-FRONT	050216	1	1				000		
+CAP-DESIGN	014218	1	1				000		
+GASKET-DOOR	048926	1	1				000		
DOOR A.-FREEZER	X51532-12			1	1	1	103		
+BEARING-FRONT	050216			2	2	2	000		
+CAP-DESIGN	014218			3	3	3	000		
DECAL-DOOR	021521			1	1	1	000		
+GASKET-DOOR	048926			2	2	2	000		
DRYER-CAPILLARY	047699	1	1	1	1	1	000	AUXILIARY	
DRYER-FILTER	048901	1	1	2	2	2	000		
GASKET-FREEZER DOOR	048926	1	1	2	2	2	000		
GEAR-REDUCER	021286	1	1	2	2	2	212		
GUIDE A.-DRIP PAN	X50752	1					103		

+ Available Separately

DESCRIPTION	PART NUMBER	750 QTY.	751 QTY.	754 QTY.	774 QTY.	794 QTY.	WARR. CLASS	REMARKS	PARTS UPDATE
GUIDE A.-DRIP PAN	X28863		1				103		
GUIDE A.-DRIP PAN	X28699			1	1		103		
GUIDE A.-DRIP PAN	X45691					1	103		
HANDLE A.-ADJUSTABLE DRAW	X26996	1	1				103		
HANDLE-DRAW	028804	1	1				103		
SCREW-ADJUSTABLE	026592	1	1				000	PLASTIC	
O-RING	015872	1	1				000		
HANDLE A.-ADJUSTABLE DRAW	X33687			3	3	3	103	J709000/UP (REPLACES X26996)	121
HANDLE-DRAW	028804			3	3	3	103		
SCREW-ADJUSTABLE	033662			3	3	3	103	STAINLESS	121
O-RING	015872			3	3	3	000		
HOOD ASSEMBLY	X35565	1	1				103		
HOOD	035434			1	1		103		
JAR-PLASTIC SYRUP	036573				2		103		
JAR-STAINLESS SYRUP	036574				2		103		
KIT A.-TUNE-UP	X49463-11	1	1				000		
BEARING-FRONT	050216	1	1				000		
CAP-DESIGN	014218	1	1				000		
GASKET-DOOR	048926	1	1				000		
O-RING	018572	4	4				000	AIR TUBE	
O-RING	014402	2	2				000	DRAW VALVE	
O-RING	016272	1	1				000	PIVOT PIN	
O-RING	016137	3	3				000	PRIME PLUG & AIR ORIFICE	
SEAL	032560	1	1				000	DRIVE SHAFT	
TOOL-O-RING REMOVAL	048260-WHT	1	1				000		
KIT A.-TUNE-UP	X49463-4			1	1	1	000		
BEARING-FRONT	050216			2	2	2	000		
CAP-DESIGN	014218			3	3	3	000		
GASKET-DOOR	048926			2	2	2	000		
O-RING	018572			8	8	8	000	AIR TUBE	
O-RING	014402			5	5	5	000	DRAW VALVE	
O-RING	016272			1	1	1	000	PIVOT PIN	

+ Available Separately

DESCRIPTION	PART NUMBER	750 QTY.	751 QTY.	754 QTY.	774 QTY.	794 QTY.	WARR. CLASS	REMARKS	PARTS UPDATE
O-RING	016137			6	6	6	000	PRIME PLUG & AIR ORIFICE	
SEAL	032560			2	2	2	000	DRIVE SHAFT	
SEAL-DRAW VALVE	034698			1	1	1	000	H-RING	
TOOL-O-RING REMOVAL	048260-WHT			1	1	1	000		
LABEL-SWITCH-POWER-OFF/ON SYMBOLS	052632			1		1	000	J808000/UP (ON POSITION ON R/S)	132
LABEL-WARN-COVER	051433	4	5	6	7	5	000		
LEG (4" w/O-RING)	013458	4					103		
LID-W/LADLE	036575				2		103		
LOUVER-SIDE (LEFT)	013631	1					103	LEFT	
LOUVER-SIDE	017471		2	2	2	2	103		
LUBRICANT-TAYLOR 4 OZ.	047518	1	1	1	1	1	000		
MAN-OPER	028754-M	1	1	1	1	1	000		
MOTOR-BEATER	021522-	1	1	2	2	2	212		
CAPACITOR-RUN (230-60-1)	027087	1	1	2	2	2	103	MAGNETEK/CENTURY 230-30-1	
CAPACITOR-RUN (230-60-1)	036084	1	1	2	2	2	103	LEESON 230-30-1	
CAPACITOR-START (230-60-1)	026315	1	1	2	2	2	103	MAGNETEK/CENTURY 230-30-1	
CAPACITOR-START (230-60-1)	045862	1	1	2	2	2	103	LEESON 230-30-1	
MOTOR-FAN (CONDENSER)	051744-27	1					103	J8108583/UP (COPELAND)	136
MOTOR-FAN (CONDENSER)	041401-27	1					103	PRIOR TO J8108583	136
+BLADE-FAN (12" PUSH)	047279	1					103		
MOTOR-FAN (w/BLADE)	027309-	1	1	1	1	1	103	SHR	
+BLADE-FAN	033499	1	1	1	1	1	103	SHR	
NUT-JAM-5/16-24	029639-BLK			3	3	3	000	J709000/UP	121
NUT-STUD (HANDSCREW)	021508	4	4				103	HANDSCREW	
NUT-STUD (LONG)	034382			2	2	2	103	LONG	
NUT-STUD (SHORT)	034383			2	2	2	103	SHORT	
ORIFICE-AIR	022465-100	1	1	2	2	2	103		
O-RING	016137	1	1	2	2	2	000		
PAIL	023348	1					000	6 QT. / 5.7 LITER	
PAIL	013163		1	1	1	1	000	10 QT. / 9.5 LITER	

+ Available Separately

DESCRIPTION	PART NUMBER	750 QTY.	751 QTY.	754 QTY.	774 QTY.	794 QTY.	WARR. CLASS	REMARKS	PARTS UPDATE
PAN-DRIP	050766	1					103		
PAN-DRIP - 11-5/8" LONG	027503		1				103		
PAN-DRIP 17-1/4" LONG	027504			1	1		103		
PAN-DRIP	035034					1	103		
PAN A.-HINGED DRIP	X41844					1	103		
PANEL-REAR	020891	1					103		
PANEL-REAR	013637		1				103		
PANEL-REAR	017563			1			103		
PANEL-REAR	041855					1	103		
PANEL-REAR-LOWER	042577				1		103		
PANEL A.-REAR-UPPER	X42574				1		103		
PANEL-SERVICE	047170		1				103		
PANEL-SERVICE	046584			1			103		
PANEL-SERVICE	047077				1		103		
PANEL-SERVICE	041856					1	103		
PANEL-UPPER RIGHT SIDE	042317	1					103		
PANEL-RIGHT SIDE	050742	1					103		
PANEL-UPPER RIGHT SIDE	028823		1	1	1		103		
PANEL-LOWER RIGHT SIDE	X24424		1				103		
PANEL-LEFT SIDE	050741	1					103		
PANEL A.-LOWER SIDE-LOUVERED-LEFT	X39075		1				103		
PANEL-UPPER SIDE	024426		1			2	103		
PANEL-UPPER SIDE-LEFT	028822			1	1		103		
PANEL A.-LOWER SIDE-LEFT	X46447			1	1	1	103		
PANEL A.-LOWER SIDE-RIGHT	X46448			1	1	1	103		
PANEL A.-FRONT	X50754	1					103		
PANEL A.-FRONT	X33237		1				103		
PANEL A.-FRONT	X32956			1			103		
PANEL A.-FRONT	X42539				1		103		
HEATER-STRIP	023953-4				1		103		
LABEL-TEMPERATURE ADJUSTMENT	030994				1		000		
PLUG-DRAIN	023953-5				1		103		
O-RING	016369				1		000		

+ Available Separately



DESCRIPTION	PART NUMBER	750 QTY.	751 QTY.	754 QTY.	774 QTY.	794 QTY.	WARR. CLASS	REMARKS	PARTS UPDATE
THERMOSTAT-ADJUSTABLE	049993				1		103		
THERMOSTAT-HI LIMIT	049992				1		103		
PANEL A.-FRONT	X41820					1	103		
PIN A.-PIVOT	X22820	1	1				103		
+O-RING	016272	1	1				000		
PIN A.-PIVOT	X20683			1	1	1	103		
+O-RING	016272			1	1	1	000		
PLATE-DECORATIVE	033239	1	1				103		
PLATE-DECORATIVE	032961			1	1	1	103		
PLATE-DECORATIVE	041854					1	103		
PLUG-DRIP TRAY HOLE	029595			1	1		000		
PLUG-PRIME	028805	1	1	2	2	2	103		
+O-RING	016137	2	2	4	4	4	000		
PROBE A.-MIX	X30922	1	1	2	2	2	103		
+DISC	030965	1	1	2	2	2	103		
+SPACER	030966	1	1	2	2	2	103		
PROBE A.-THERMISTOR - HOPPER	X50717	1	1	1	1	1	103	794 - J8110000/UP	136
PROBE A.-THERMISTOR - HOPPER	X34466					1	103	PRIOR TO J8110000	136
PROBE A.-THERMISTOR - BARREL	X31602	1	1	2	2	2	103		
PULLEY (BEATER MOTOR)	016403	1	1	2	2	2	103	BEATER MOTOR	
PULLEY (GEAR)	027822	1	1	2	2	2	103	GEAR	
PUMP-TOPPING	036623				2		103		
BALL	032752				4		000		
BODY-VALVE-SYRUP PUMP	048166				2		103		
O-RING-1-5/16 OD	048149				2		000		
O-RING-1" OD	048148				2		000		
COLLAR-GAGING-1/202	035514				2		103		
CYLINDER-SYRUP PUMP	051065				2		103		
INSERT-PLUNGER	032758				2		103		
KNOB-PLUNGER (w/O-RING)	032762-				2		103	032762-BRN - 032762-TAN	
+O-RING	016369				2		000		
LID-PUMP	036822				2		103		
NUT-PLUNGER	036577				2		103		

+ Available Separately

DESCRIPTION	PART NUMBER	750 QTY.	751 QTY.	754 QTY.	774 QTY.	794 QTY.	WARR. CLASS	REMARKS	PARTS UPDATE
NUT-SPOUT	036821				2		103		
PLUNGER	036578				2		103		
SEAL ASSEMBLY (w/O-RING)	X33057				2		103		
+O-RING	019330				2		000		
SPRING-PLUNGER	032761				2		000		
TUBE-DISCHARGE	050912				2		103		
TUBE-PLUNGER	032757				2		103		
WASHER-NYLON	032760				2		000		
RELAY-COMPRESSOR	012725-	1	1	2	2	2	103		
RELAY-SPDT-30A-240V (A/C)	032607-		1	1	1	1	103	BLOWER **750-FOR FAN MOTOR 041401-27	136
SANITIZER-KAY-5	041082	1	1	1	1	1	000		
SHAFT-BEATER DRIVE	032564	1	1	2	2	2	103		
+SEAL-DRIVE SHAFT	032560	1	1	2	2	2	000		
SHELL A.-INSULATED	X50745	1					512		
SHELL A.-INSULATED	X49785		1				512		
SHELL A.-INSULATED	X50327			1	1	1	512		
SHELL A.-INSULATED	X51711					1	512	J8110000/UP	136
SHELL A.-INSULATED	X41786					1	512	PRIOR TO J8110000	136
+STUD-NOSE CONE	022822	4	4	4	4	4	103		
SHIELD-SPLASH	022763	1	1				103		
SHIELD-SPLASH	022766			1	1	1	103		
SHIELD-SPLASH	022765					1	103		
STARTER-BEATER LINE	041950-	1	1	2	2	2	103		
OVERLOAD-THERMAL	047150-	1	1	2	2	2	103		
SWITCH-PRESSURE 405 PSI (A/C) - NEW	052663	1					103	J8108583/UP (COPELAND)	136
SWITCH-PRESSURE 440 PSI (A/C)	048230	1	1	2	2	2	103	750 - PRIOR TO J8108583	136
SWITCH-TOGGLE (POWER SWITCH)	024295	1	1				103		
SWITCH-TOGGLE (POWER SWITCH)	037394			1	1	1	103		
SWITCH-TOGGLE (HEATER SWITCH)	012626				1		103		
SWITCH A.-DRAW	X33322-SER	1	1				103		
ARM A.-SWITCH	X33326	1	1				103		
BRACKET A.-SWITCH	X43722	1	1				103		

+ Available Separately

DESCRIPTION	PART NUMBER	750 QTY.	751 QTY.	754 QTY.	774 QTY.	794 QTY.	WARR. CLASS	REMARKS	PARTS UPDATE
E-RING	049178	1	1				000		
PIN-PIVOT	015478	1	1				103		
SPRING-LEFT RETURN	041660	1	1				103		
SPRING-RIGHT RETURN	041661	1	1				103		
SWITCH-MICRO	028889	1	1				103		
SWITCH A.-DRAW	X38547			1	1	1	103		
ARM-SWITCH-LEFT	038649			1	1	1	103		
ARM-SWITCH-RIGHT	038650			1	1	1	103		
BRACKET A.-SWITCH	X38252			1	1	1	103		
E-RING	032190			4	4	4	000		
PIN-PIVOT	038484			1	1	1	103		
ROD-SPRING RETAINER	038254			1	1	1	103		
SPRING-EXTENSION	038922			2	2	2	103		
SPRING-LEFT RETURN	038923			1	1	1	103		
SPRING-RIGHT RETURN	038924			1	1	1	103		
SWITCH A.-DRAW	X39269			1	1	1	103		
BRACKET-SWITCH	039264			1	1	1	103		
SWITCH-MIRCO	039252			2	2	2	103		
TRAY-FRONT DRIP	013690	1	1				103		
TRAY-FRONT DRIP	014533			1	1		103		
TRAY-FRONT DRIP	020157					1	103		
TRIM-FRONT	020889	1					103		
TRIM-LEFT REAR CORNER	020678	1					103		
TRIM-LEFT REAR CORNER	020882		1				103		
TRIM-LEFT REAR CORNER	013761			1	1		103		
TRIM-LEFT REAR CORNER	041852					1	103		
TRIM-RIGHT REAR CORNER	020677	1					103		
TRIM-RIGHT REAR CORNER	020883		1				103		
TRIM-RIGHT REAR CORNER	013663			1	1		103		
TRIM-RIGHT REAR CORNER	041853					1	103		
TUBE A.-AIR	X29429-2	1	1	2	2	2	103		
+O-RING	018572	4	4	8	8	8	000		
VALVE-ACCESS	047016	2	1	2	2	2	103		

+ Available Separately

DESCRIPTION	PART NUMBER	750 QTY.	751 QTY.	754 QTY.	774 QTY.	794 QTY.	WARR. CLASS	REMARKS	PARTS UPDATE
VALVE-ACCESS	044455	1	1	2			103	750 W/BRISTOL COMPRESSOR	136
VALVE-ACCESS	043232		1		2	2	103		
VALVE-ACCESS	044404	1	1	1	1	1	103		
VALVE-ACCESS	029406		1	1	1	1	103		
VALVE-AUTOMATIC EXPANSION	046365	1	1	2	2	2	103		
+BOOT-EXPANSION VALVE	050900	1	1	2	2	2	000		
VALVE-E.P.R.	022665	1	1	1	1	1	103		
VALVE A.-DRAW	X18303	1	1	3	3	3	103	J7060000 (REPLACES X45380)	118
+O-RING	014402	2	2	6	6	6	000		
VIDEO-TRAINING FILM	038047-	1	1	1	1	1	000		
<b>OPTIONAL FEATURES</b>									
<b>AIR/MIX PUMP</b>									
BEARING-FRONT	023262		1				000	use without shoes	
BEARING-FRONT	050348		1	2			000	use w/shoes 050346/050347	
SHOE-FRONT HELIX-REAR	050346		1	2			000	use with 050348 bearing	
SHOE-FRONT HELIX-FRONT	050347		1	2			000	use with 050348 bearing	
BEATER ASSEMBLY	X46231		1	2			103		
+BLADE-SCRAPER	046235		2	4			000		
+CLIP-SCRAPER BLADE	046236		2	4			103		
PIN-SCRAPER BLADE	014170		2	4			000		
BOARD-LOGIC	X42002SER1		1	2			212		
CAPACITOR-START (PUMP)	037251-		1	2			103		
DECAL-CLEAN AND SANITIZE	042170		1	1			000		
DECAL-DECORATIVE	033231		1				000		
DECAL-DECORATIVE	033232		1	1			000		
GASKET-HOPPER	038375		1	2			000		
GUIDE A.-DRIP PAN-PUMP	X48433		1				103	hopper pump	
HOOD ASSEMBLY	X41996		1				103		
HOOD	013667			1			103		

+ Available Separately

DESCRIPTION	PART NUMBER	750 QTY.	751 QTY.	754 QTY.	774 QTY.	794 QTY.	WARR. CLASS	REMARKS	PARTS UPDATE
KIT A.-TUNE-UP	X49463-9		1				000		
BAND-CHECK (LIQUID VALVE BODY)	020050		2				000		
BAND-CHECK (LIQUID VALVE BODY)	033215		1				000		
BEARING-FRONT (FREEZER DOOR)	023262		1				000	use without shoes	
BEARING-FRONT (FREEZER DOOR)	050348		1				000	use w/shoes 050346/050347	
SHOE-FRONT HELIX-REAR	050346		1				000	use with 050348 bearing	
SHOE-FRONT HELIX-FRONT	050347		1				000	use with 050348 bearing	
CAP-DESIGN (FREEZER DOOR)	014218		1				000		
GASKET-DOOR	048926		1				000		
O-RING (PRIME PLUG)	016137		3				000		
O-RING (DRAW VALVE)	014402		2				000		
O-RING (PUMP DRIVE SHAFT)	008904		1				000		
O-RING (LIQUID VALVE BODY)	018664		1				000		
O-RING (LIQUID VALVE BODY & PISTON)	020051		3				000		
O-RING (MIX INLET TUBE)	015835		1				000		
O-RING (MIX FEED TUBE)	016132		2				000		
O-RING (PIVOT PIN)	016272		1				000		
POPPET-RUBBER	022473		1				000		
SEAL (AIR INLET FITTING)	045327		1				000		
SEAL (BEATER DRIVE SHAFT)	032560		1				000		
O-RING (PUMP DRIVE SHAFT)	048632		2				000		
SPRING	022456		1				000		
KIT A.-TUNE-UP	X49463-19			1			000		
BAND-CHECK (LIQUID VALVE BODY)	020050			4			000		
BAND-CHECK (LIQUID VALVE BODY)	033215			2			000		
BEARING-FRONT (FREEZER DOOR)	050348			2			000	023262 used without shoes	
CAP-DESIGN (FREEZER DOOR)	014218			3			000		
GASKET-DOOR	048926			2			000		
O-RING (PRIME PLUG)	016137			4			000		
O-RING (DRAW VALVE)	014402			7			000		
O-RING (DRIVE CRANK)	008904			2			000		
O-RING (LIQUID VALVE BODY)	018664			2			000		

+ Available Separately

DESCRIPTION	PART NUMBER	750 QTY.	751 QTY.	754 QTY.	774 QTY.	794 QTY.	WARR. CLASS	REMARKS	PARTS UPDATE
O-RING (LIQUID VALVE BODY & PISTON)	020051			6			000		
O-RING (MIX INLET TUBE)	015835			2			000		
O-RING (MIX FEED TUBE)	016132			4			000		
O-RING (PIVOT PIN)	016272			1			000		
O-RING (PUMP DRIVE SHAFT)	048632			4			000		
POPET-RUBBER	022473			2			000		
SEAL-DRAW VALVE	034698			1			000		
SEAL (AIR INLET FITTING)	045327			2			000		
SEAL (BEATER DRIVE SHAFT)	032560			2			000		
SHOE-FRONT HELIX-REAR	050346			2			000	use with 050348 bearing	
SHOE-FRONT HELIX-FRONT	050347			2			000	use with 050348 bearing	
SPRING	022456			2			000		
TOOL-O-RING REMOVAL	048260-WHT			1			000		
LOUVER-SIDE-RIGHT	017471			1			103		
LOUVER-SIDE-LEFT	028288			1			103		
MOTOR-REDUCER	036955-34		1	2			103		
OVERLOAD (MOTOR REDUCER)	044464		1	2			103		
PAN-DRIP	048435		1				103	HOPPER PUMP	
PAN A.-DRIP	X38198			1			103		
PANEL-REAR	048203		1				103		
PUMP A.-COAXIAL AIR/MIX	X45316-B		1	2			103		
BAND-CHECK (LIQUID VALVE BODY)	020050		2	4			000		
BAND-CHECK (LIQUID VALVE BODY)	033215		1	2			000		
BODY A.-LIQUID VALVE	X46860-B		1	2			103		
+CLIP-LOCKING	044731		1	2			103		
+CLIP-PUMP	044641		1	2			103		
CYLINDER A.-PUMP	X44755		1	2			103		
O-RING (LIQUID VALVE BODY)	018664		1	2			000		
O-RING (LIQUID VALVE BODY & PISTON)	020051		3	6			000		
PIN A.-PUMP	X36950		1	2			103		
PISTON	045319-B		1	2			103		

+ Available Separately

DESCRIPTION	PART NUMBER	750 QTY.	751 QTY.	754 QTY.	774 QTY.	794 QTY.	WARR. CLASS	REMARKS	PARTS UPDATE
POPPET-RUBBER	022473		1	2			000		
SPRING	022456		1	2			000		
TUBE A.-MIX INLET	X45318		1	2			103		
O-RING	015835		1	2			000		
SEAL	045327		1	2			000		
RELAY (MOTOR REDUCER)	039725-		1	2			103		
SHAFT A.-DRIVE	X39084		1	2			103		
O-RING (DRIVE CRANK)	008904		1	2			000		
O-RING (DRIVE CRANK)	048632		2	4			000		
SHELL A.-INSULATED	X50332		1				512		
SHELL A.-INSULATED	X50376			1			512		
SLEEVE A.-MIX PUMP	X45012		1	2			103		
+NUT-PUMP SLEEVE	036933		1	2			103		
TUBE A.-MIX FEED	X44666		1				103		
+O-RING	016132		2				000		
TUBE A.-FEED (LEFT)	X44662			1			103		
TUBE A.-FEED (RIGHT)	X44664			1			103		
O-RING-FEED TUBE	016132			4			000		
VIDEO-TRAINING	047247-		1	1			000		
<b>WATER COOLED</b>									
BLOWER	012796-		1	1	1	1	103		
+GUARD-BLOWER	022505		1	1	1	1	103		
CONDENSER	049309	1					103		
CONDENSER	048287		1	2	2	2	103		
MOTOR-FAN	015184-	1					103		
+BLADE-FAN (10" PUSH)	013043	1					103		
PANEL A.-LOWER SIDE (R & L)	X24424		2	2	2	2	103		
SWITCH-PRESSURE	048231	1	1	2	2	2	103		
VALVE-WATER	046686	1	1	2	2	2	103		

+ Available Separately

DESCRIPTION	PART NUMBER	750 QTY.	751 QTY.	754 QTY.	774 QTY.	794 QTY.	WARR. CLASS	REMARKS	PARTS UPDATE
<b>50 CYCLE</b>									
BELT-AX35	022848				4		000		
BELT-AX32	032769					4	000		
BLOCK-TERMINAL (230-50-1)	039421	1	1	2			103		
BLOCK-TERMINAL (220/440-50-3)	039424	1	1	2	2	2	103		
CAPACITOR-RUN (BEATER MOTOR)	023606	1	1	2	2	2	103	CENTURY/MAGNETEK	
CAPACITOR-RUN (BEATER MOTOR)	035765-27	1	1	2	2	2	103	LEESON	
CAPACITOR-START (BEATER MOTOR)	028315	1	1	2	2	2	103	CENTURY/MAGNETEK	
CAPACITOR-START (BEATER MOTOR)	026659	1	1	2	2	2	103	LEESON	
COMPRESSOR (MAIN - HP62)	048727-	1					512	BRISTOL	
CAPACITOR-RUN (230-50-1)	027087	1					103		
CAPACITOR-START (230-50-1)	031790	1					103		
RELAY-START (230-50-1)	048766	1					103		
COMPRESSOR (MAIN - HP62)	048259-		1	2	2		512	BRISTOL	
CAPACITOR-RUN (230-50-1)	023739		1	2			103		
CAPACITOR-START (230-50-1)	031790		1	2			103		
RELAY-START (230-50-1)	038146		1	2			103		
COMPRESSOR-MAIN (HP62)	047519-					2	512	TECUMSEH	
CAPACITOR-RUN (230-50-1)	029439					2	103		
CAPACITOR-START (230-50-1)	036048					2	103		
RELAY-START (230-50-1)	036047					2	103		
MOTOR-FAN	047178-34	1					103		
BLADE-FAN (12" PUSH)	047279	1					103		
PULLEY (BEATER MOTOR)	011545	1	1	2	2	2	103		

+ Available Separately



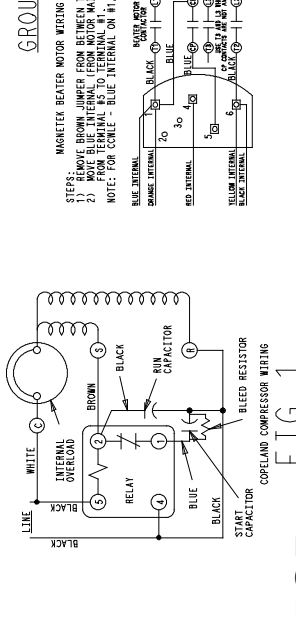
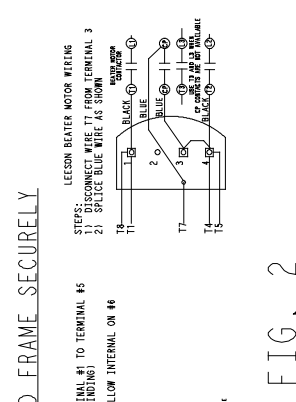
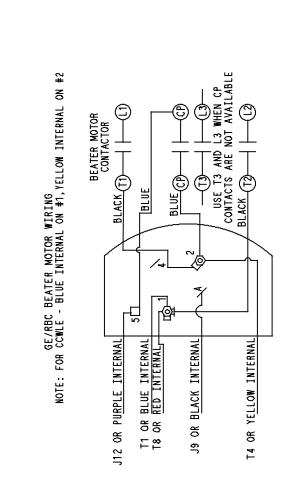
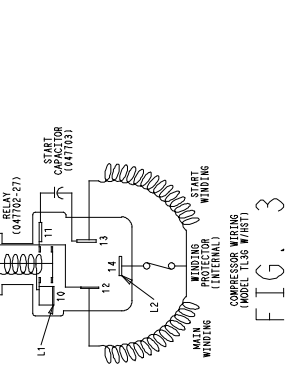
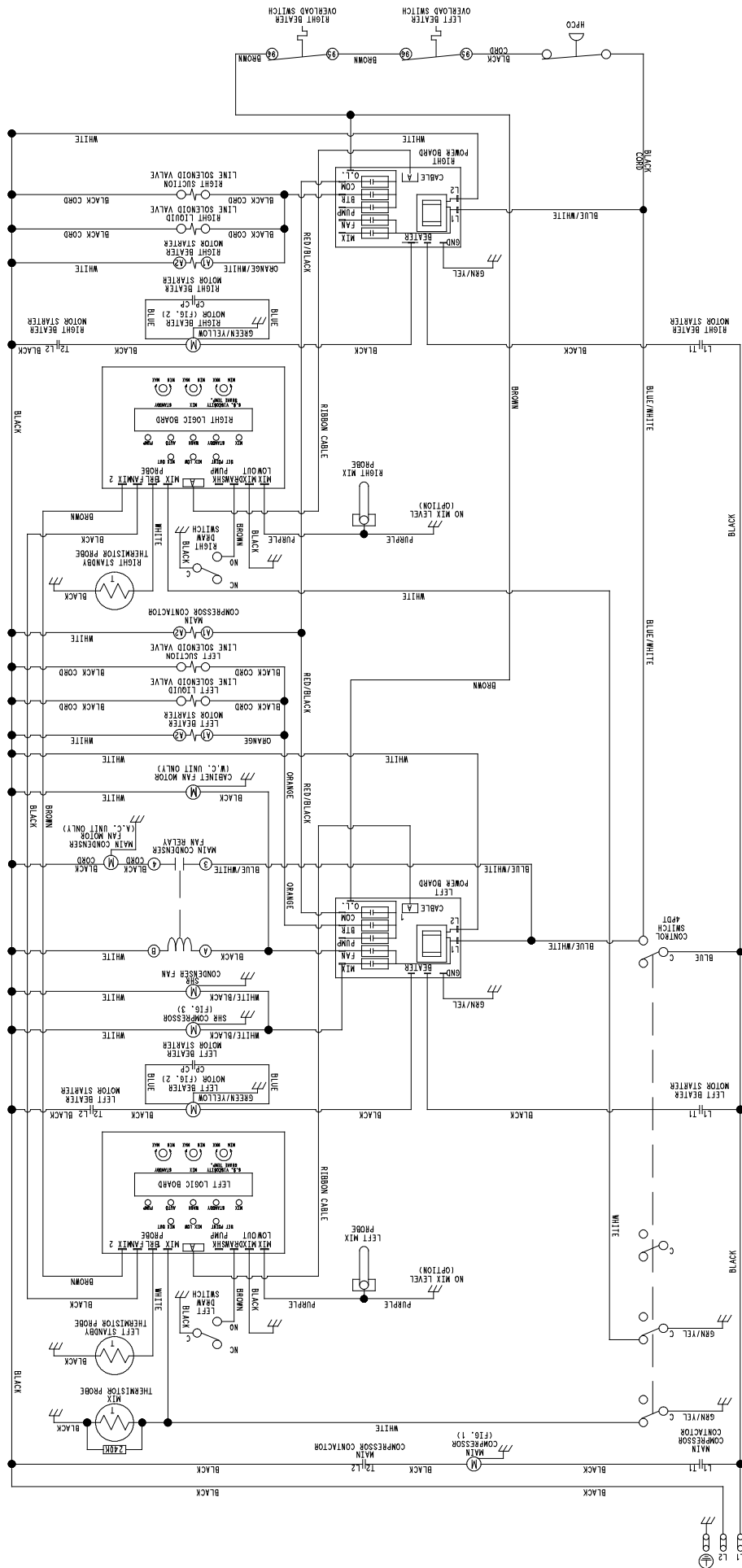

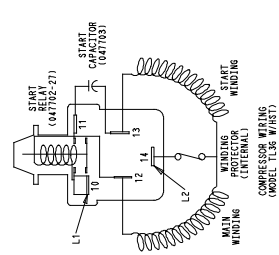
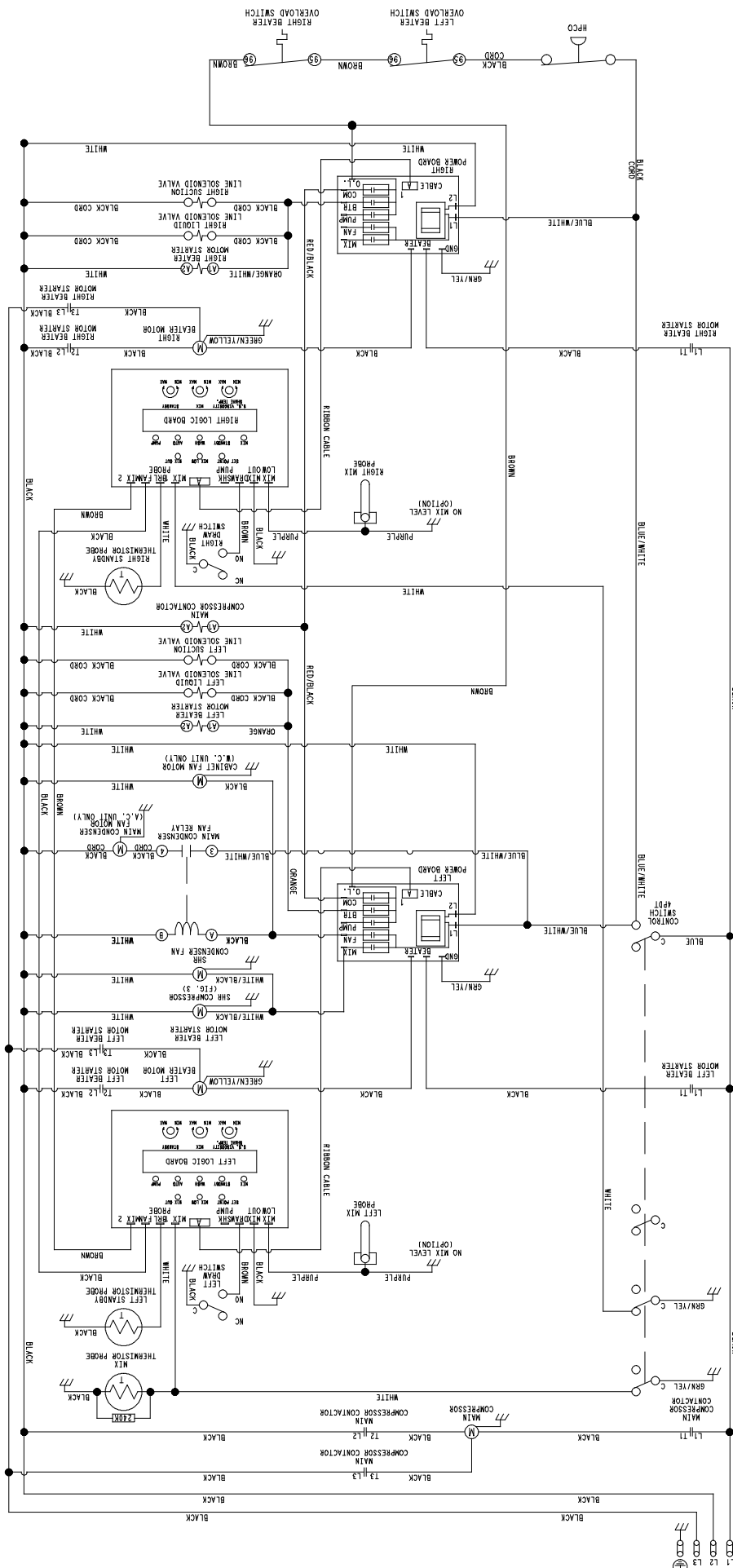

**GROUND FRAME SECURELY**  
 COMPRESSOR AND BLOWER MOTORS PROTECTED  
 UNDER PRIMARY SINGLE PHASING CONDITIONS

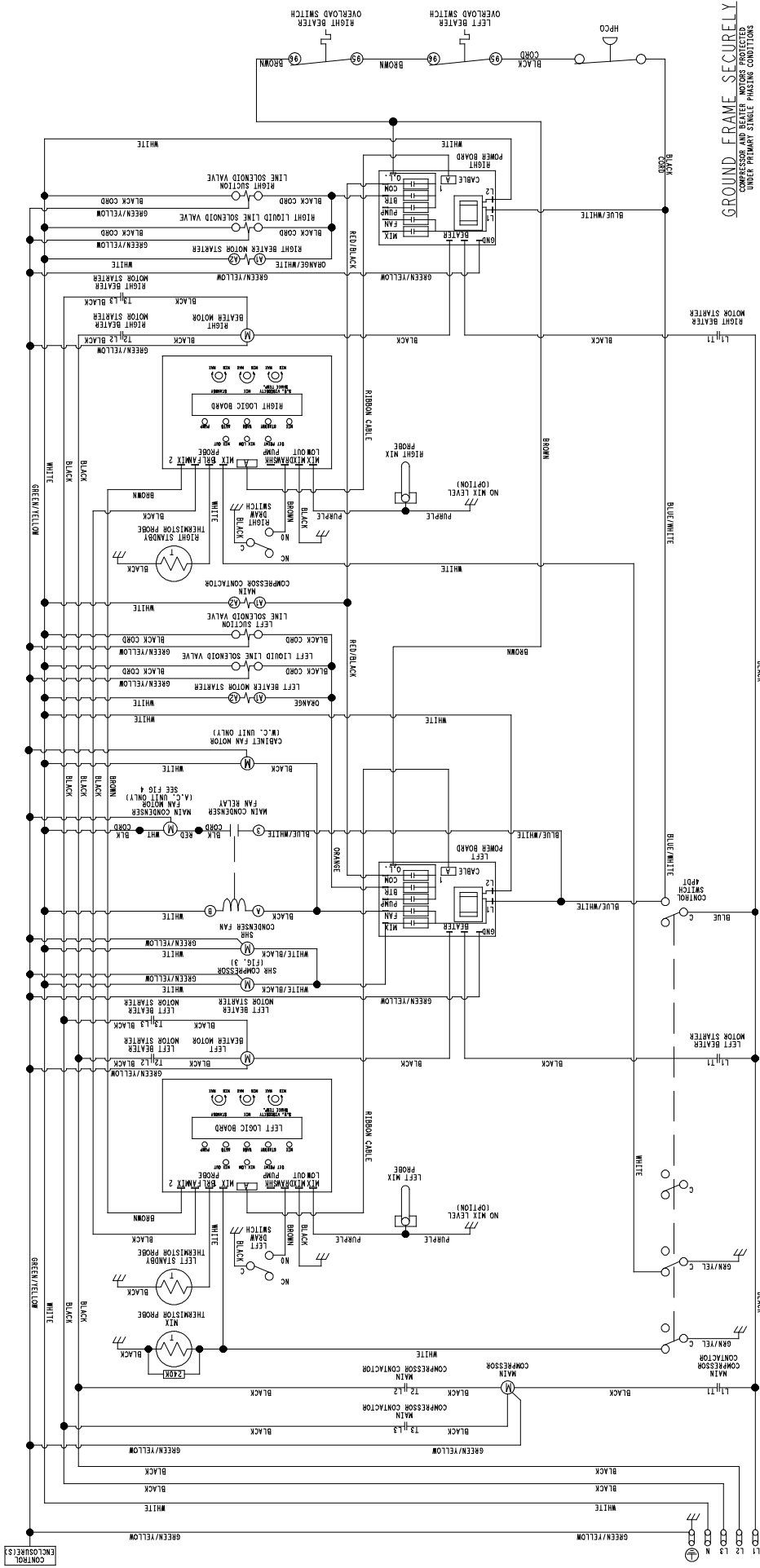

GROUND FRAME SECURELY  
COMPRESSOR AND BEATER MOTOR PROTECTED  
UNDER PERMANENT STABLE PHASING CONDITIONS

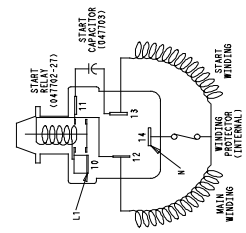

COMPRESSOR WIRING  
(MODEL TL3G W/HST)  
FIG. 3

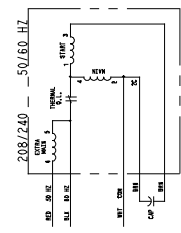

6E MOTOR SCHEMATIC  
FIG. 4



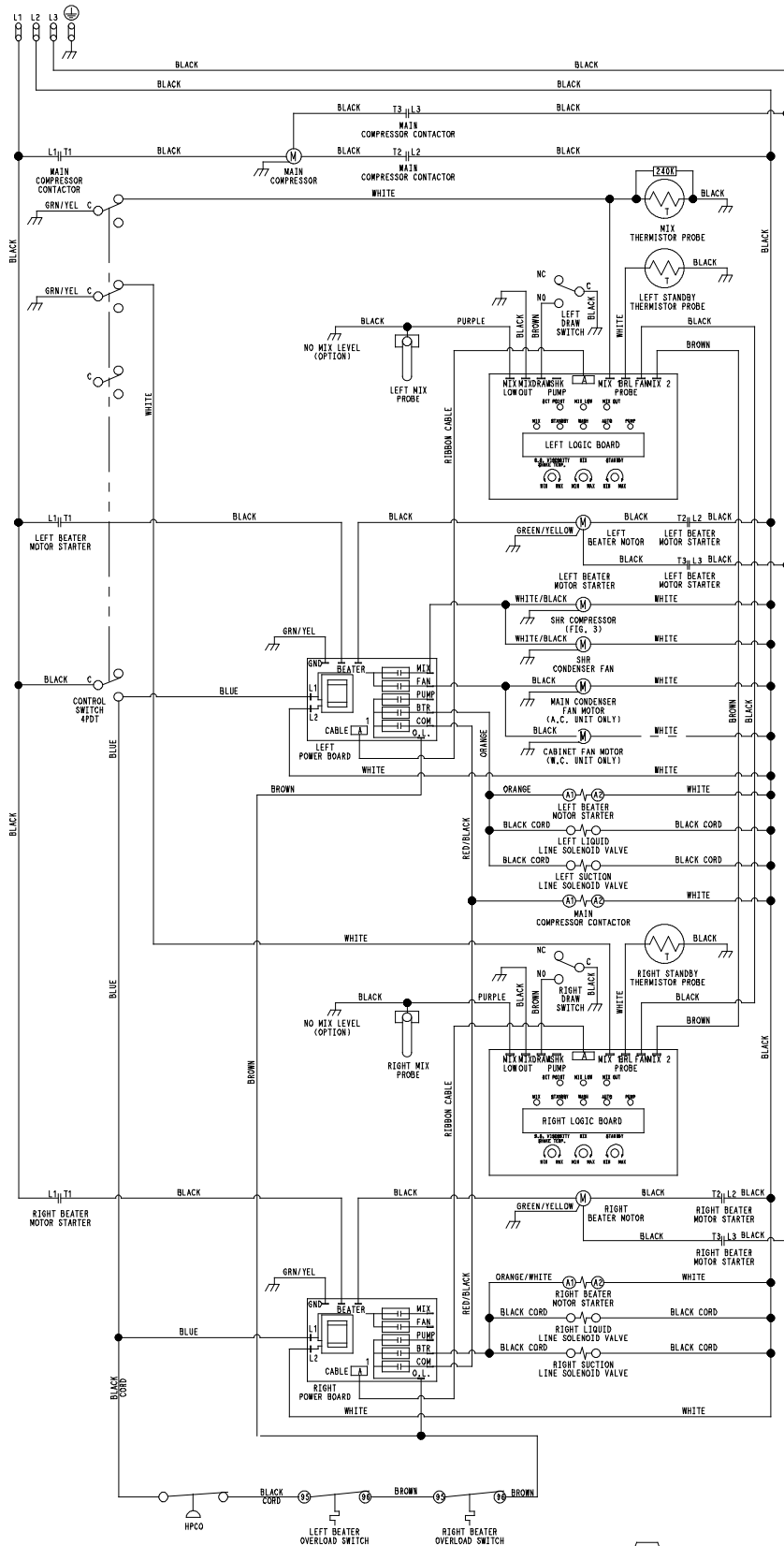

**GROUND FRAME SECURELY**  
 COMPRESSOR AND BEATER MOTORS PROTECTED  
 UNDER PRIMARY SINGLE PHASING CONDITIONS

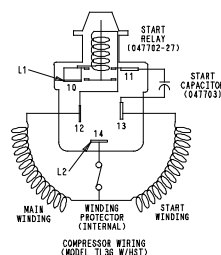

FIG. 3

### GROUND FRAME SECURELY

COMPRESSOR AND BEATER MOTORS PROTECTED UNDER PRIMARY SINGLE PHASING CONDITIONS

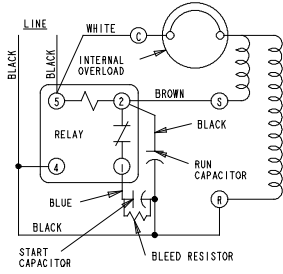
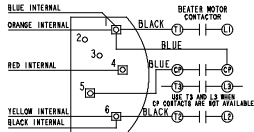

FIG. 1

### MAGNETEK BEATER MOTOR WIRING

- STEPS:  
 1) REMOVE BROWN JUMPER FROM BETWEEN TERMINAL #1 TO TERMINAL #5  
 2) MOVE BLUE INTERNAL (FROM MOTOR MAIN WINDING) FROM TERMINAL #5 TO TERMINAL #1  
 NOTE: FOR CCWLE - BLUE INTERNAL ON #1, YELLOW INTERNAL ON #6



### LEESON BEATER MOTOR WIRING

- STEPS:  
 1) DISCONNECT WIRE T1 FROM TERMINAL 3  
 2) SPLICE BLUE WIRE AS SHOWN

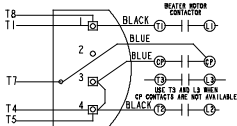

FIG. 2

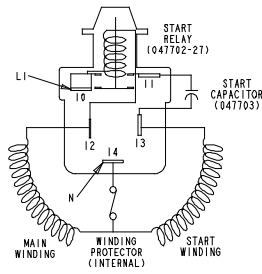
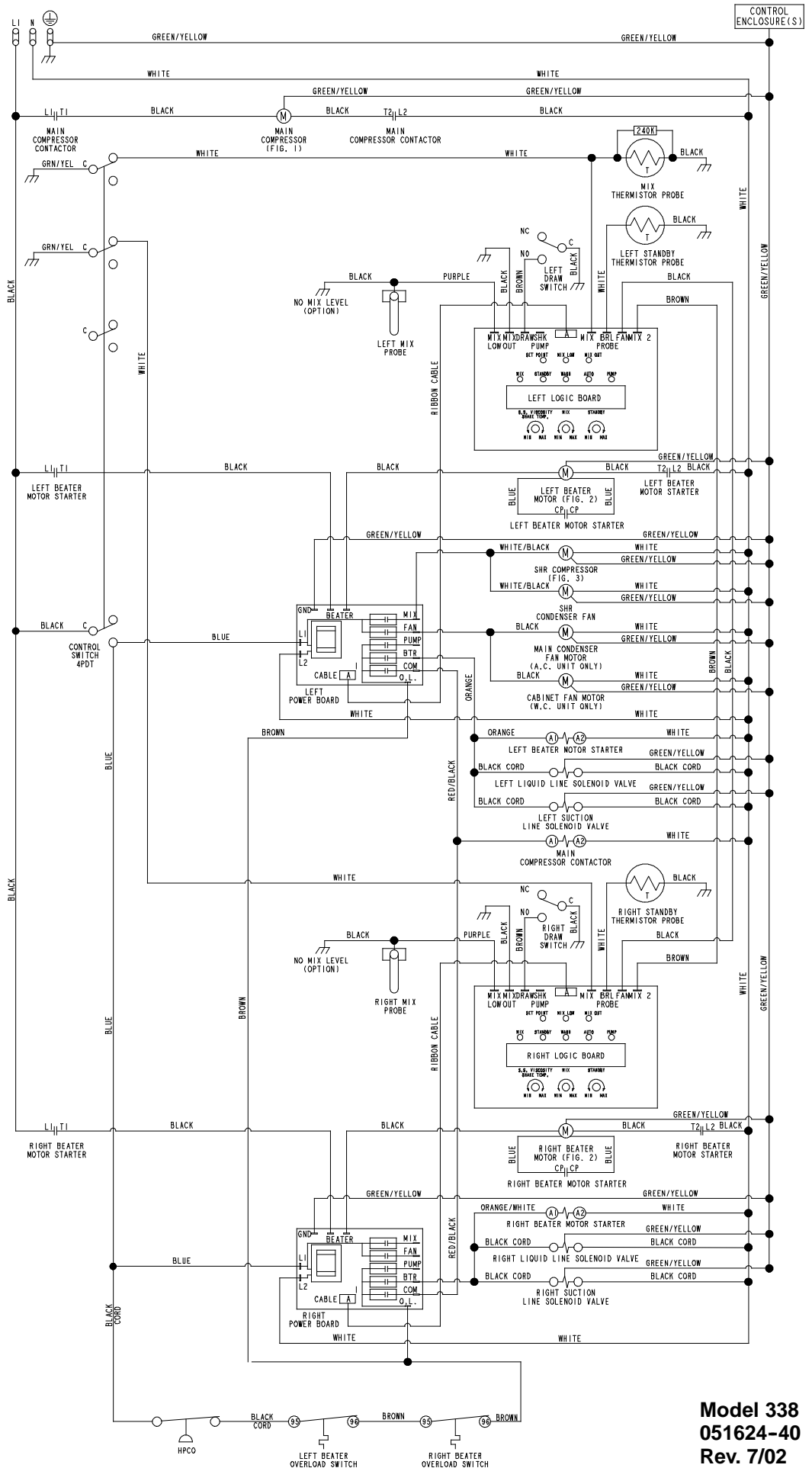
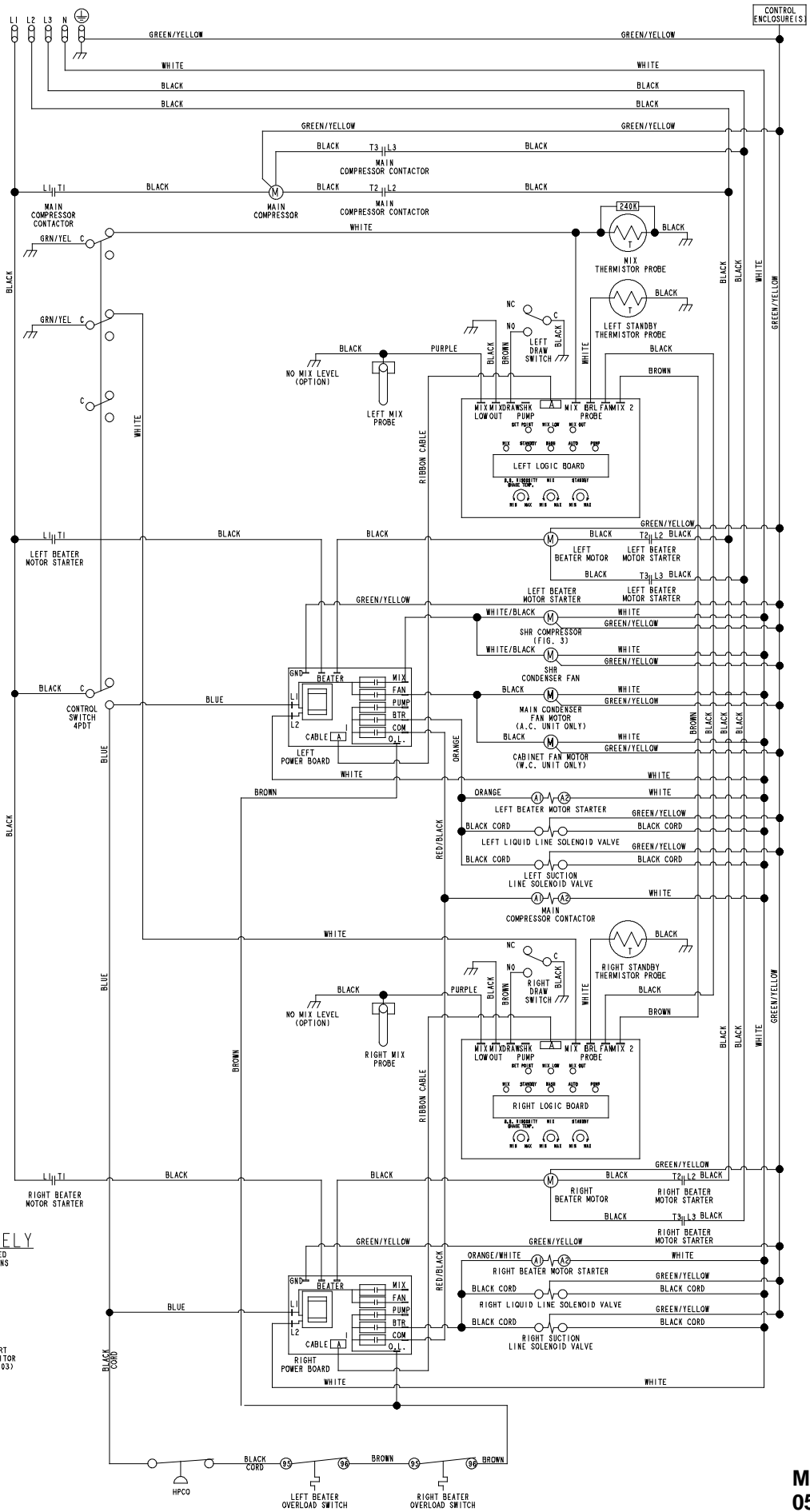

FIG. 3





**GROUND FRAME SECURELY**

COMPRESSOR AND BEATER MOTORS PROTECTED UNDER PRIMARY SINGLE PHASING CONDITIONS

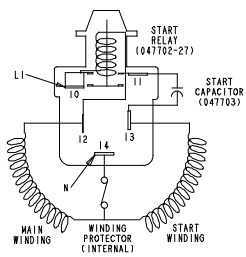
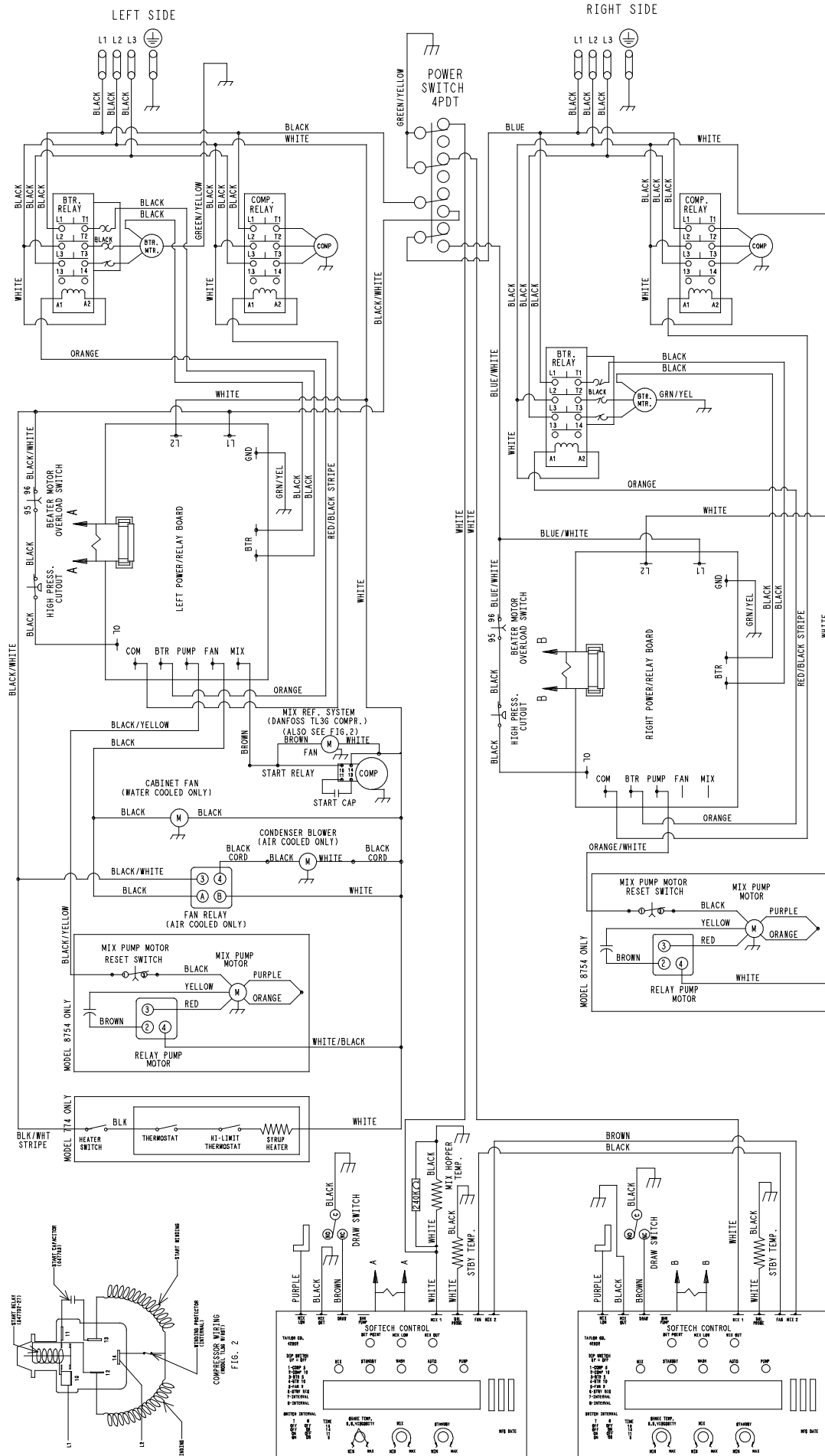

FIG. 3







COMPRESSOR AND BEATER MOTOR PROTECTED  
UNDER PRIMARY SINGLE PHASING CONDITIONS

GROUND FRAME SECURELY

LEFT SIDE

RIGHT SIDE

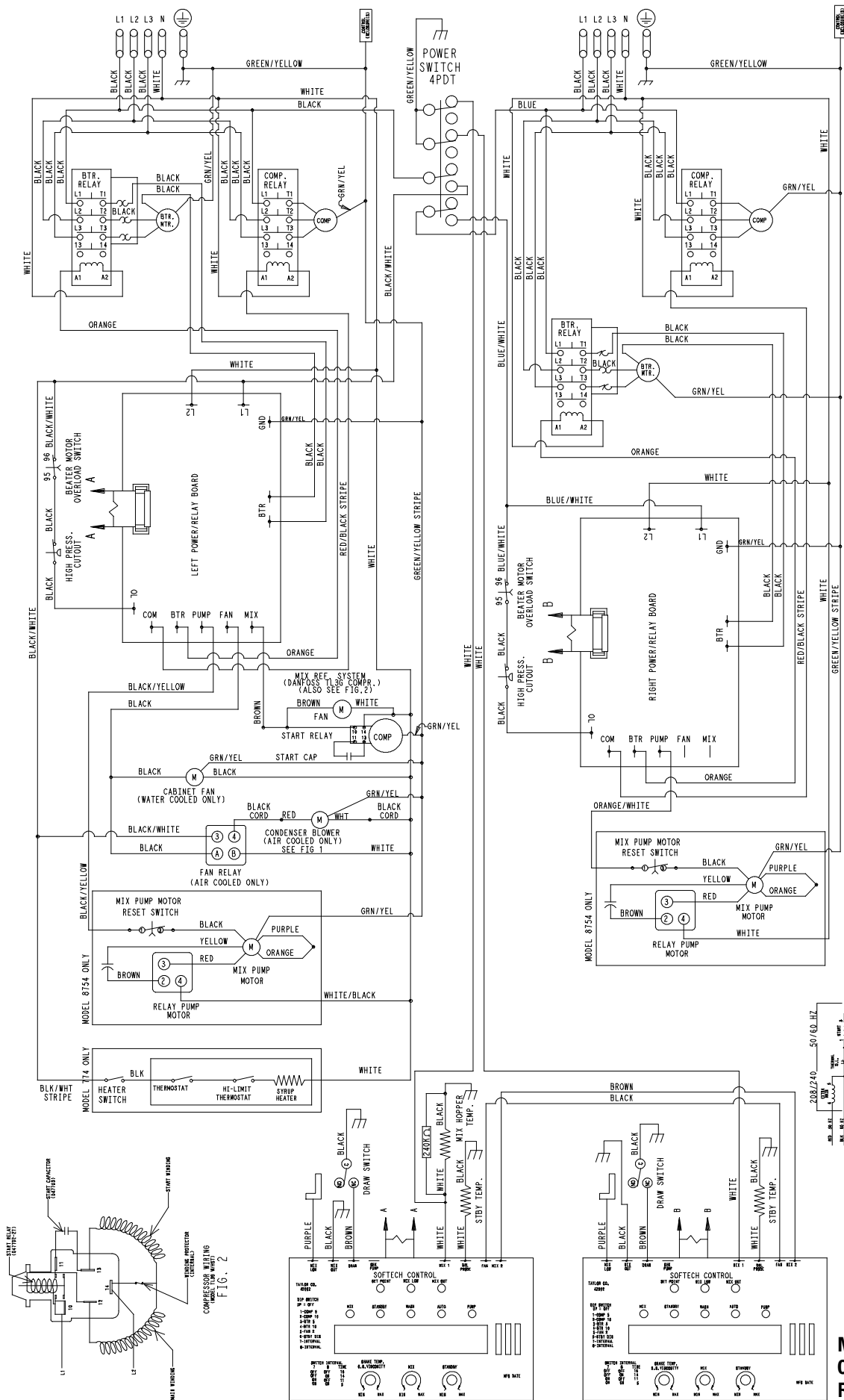

COMPRESSOR AND BEATER MOTOR PROTECTED  
UNDER PRIMARY SINGLE PHASING CONDITIONS

GROUND FRAME SECURELY

FIG. 1

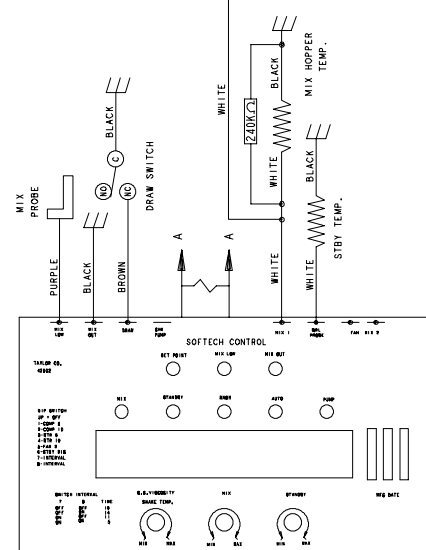
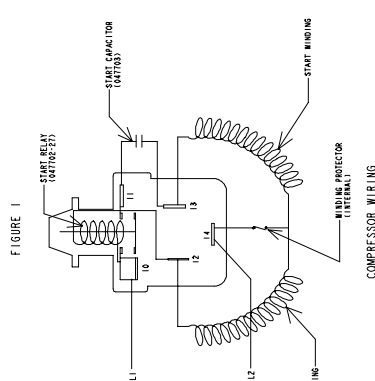
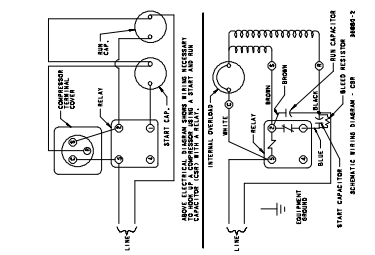
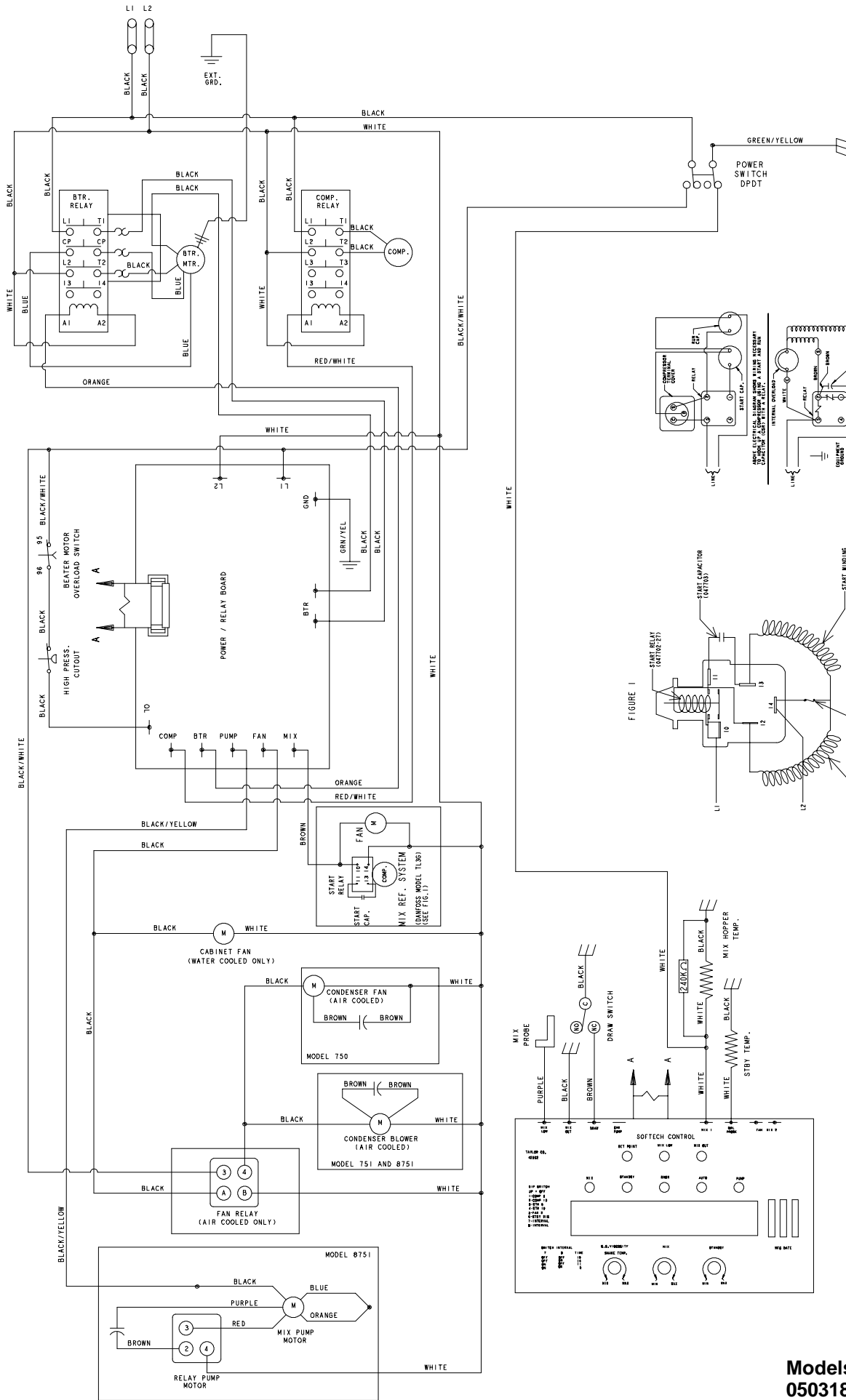

**Models (8)750 & (8)751  
050318-27**

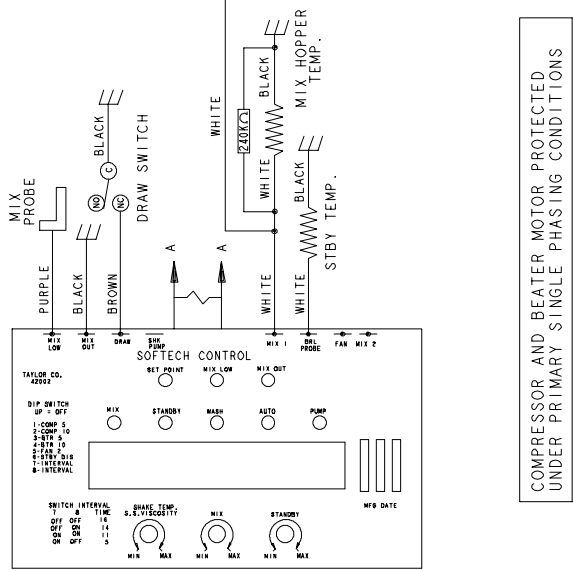
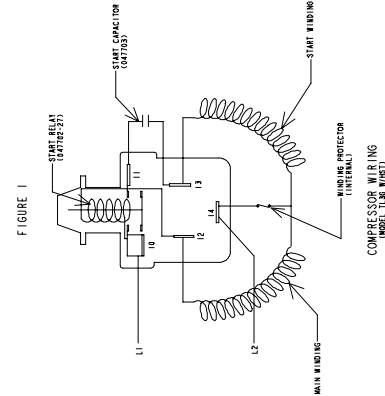
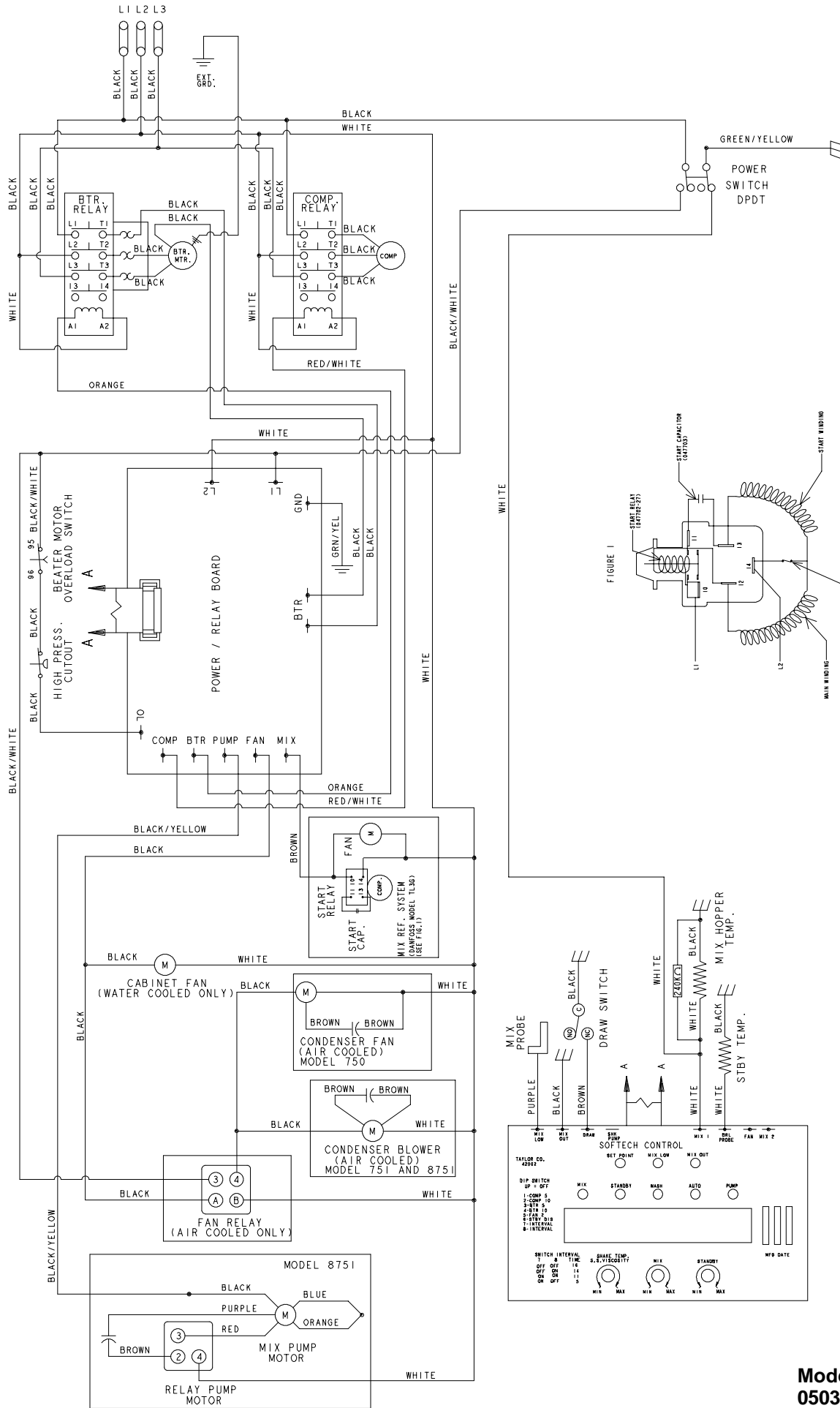

COMPRESSOR AND BEATER MOTOR PROTECTED UNDER PRIMARY SINGLE PHASING CONDITIONS

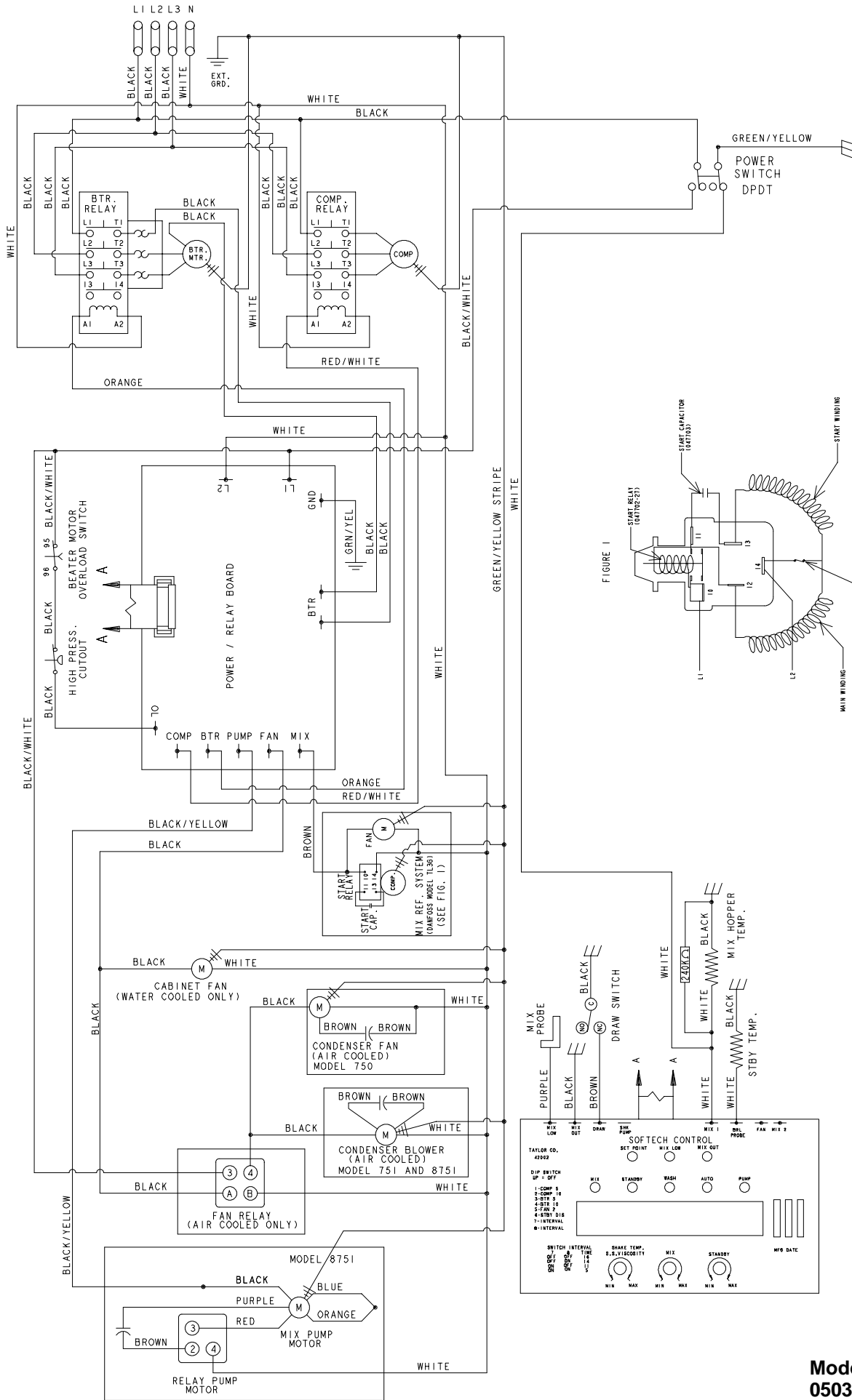

COMPRESSOR AND BEATER MOTOR PROTECTED UNDER PRIMARY SINGLE PHASING CONDITIONS

Models (8)750 & (8)751  
050318-58

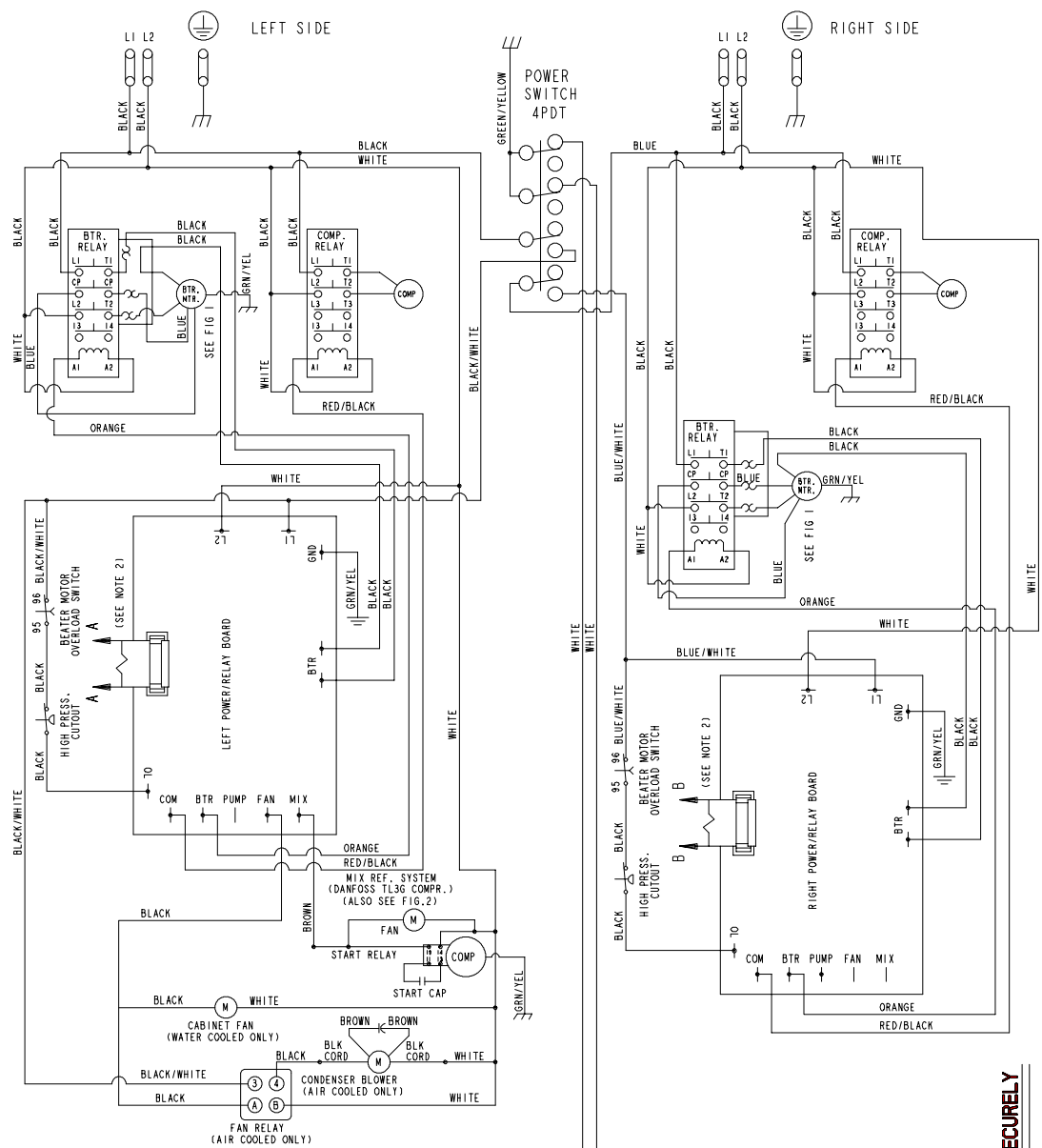
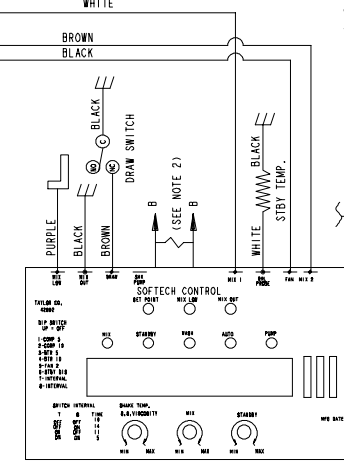
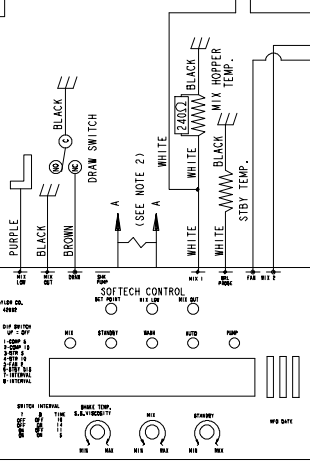
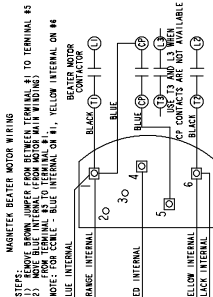
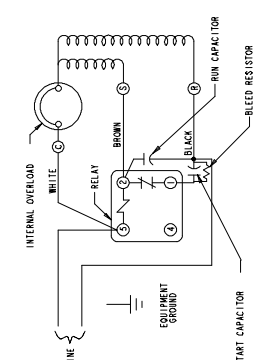
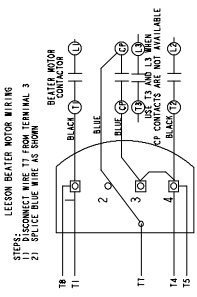

**GROUND FRAME SECURELY**

- NOTE:
1. STATIC ELECTRICITY MAY CAUSE DAMAGE TO SOLID STATE COMPONENTS. ELIMINATE STATIC BY TOUCHING GROUNDING POINT BEFORE HANDLING SOLID STATE COMPONENTS.
  2. RED WIRE ON RIBBON CABLES MUST BE CONNECTED TO PIN 1 AT EACH END.

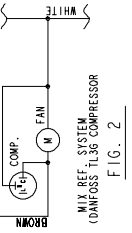

**Model 794**  
**048199-27**  
 Rev. 10/01

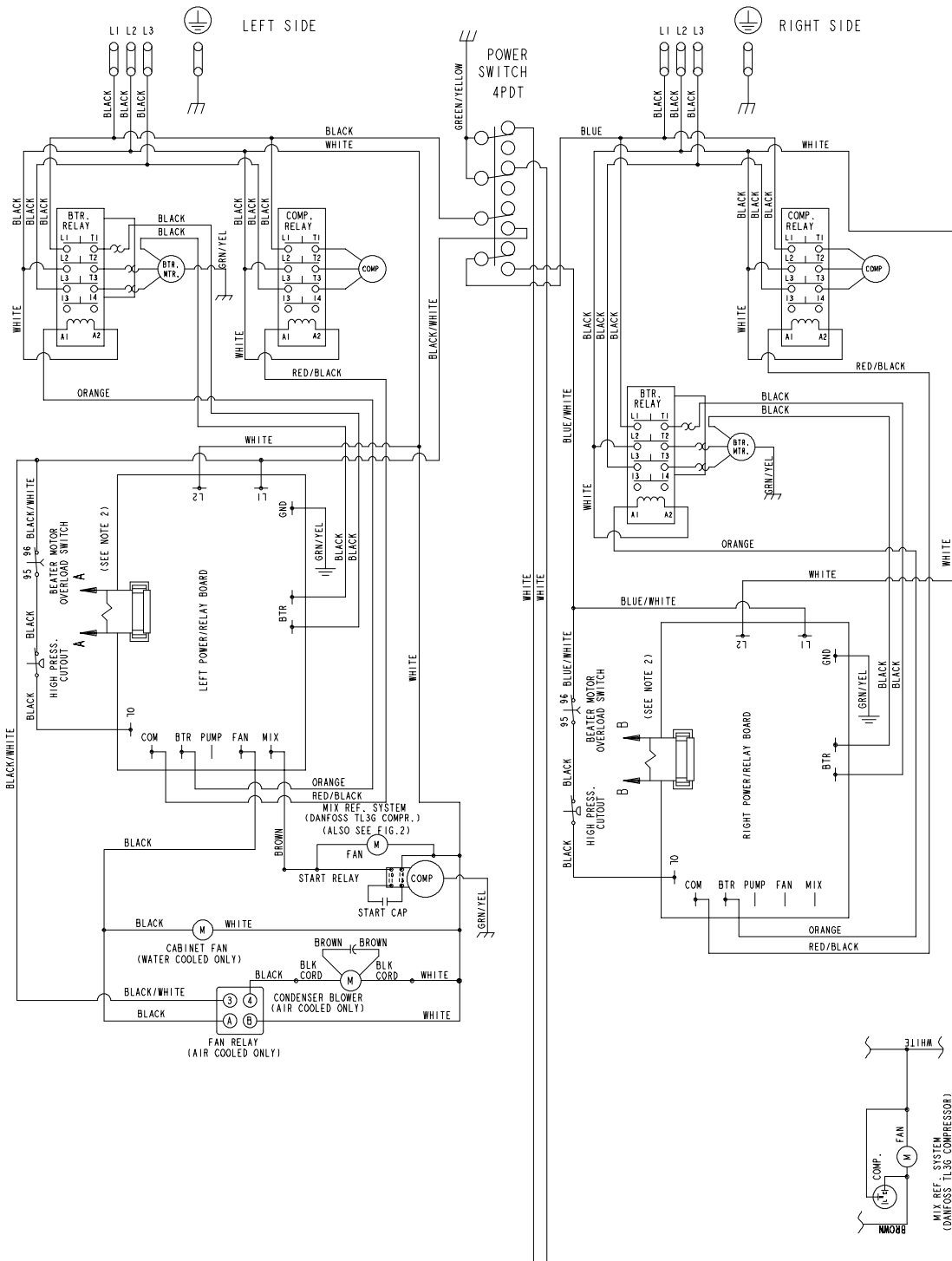

GROUND FRAME SECURELY

GROUND FRAME SECURELY

COMPRESSOR AND BEATER MOTOR PROTECTED UNDER PRIMARY SINGLE PHASING CONDITIONS

- NOTE:
1. STATIC ELECTRICITY MAY CAUSE DAMAGE TO SOLID STATE COMPONENTS. DISCHARGE BY TOUCHING METAL PARTS OF THE UNIT BEFORE HANDLING SOLID STATE COMPONENTS.
  2. RED WIRE ON RIBBON CABLES MUST BE CONNECTED TO PIN 1 AT EACH END.

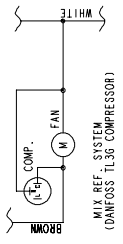

MIX REF. SYSTEM (DANFOSS TL36 COMPRESSOR)

FIG. 1

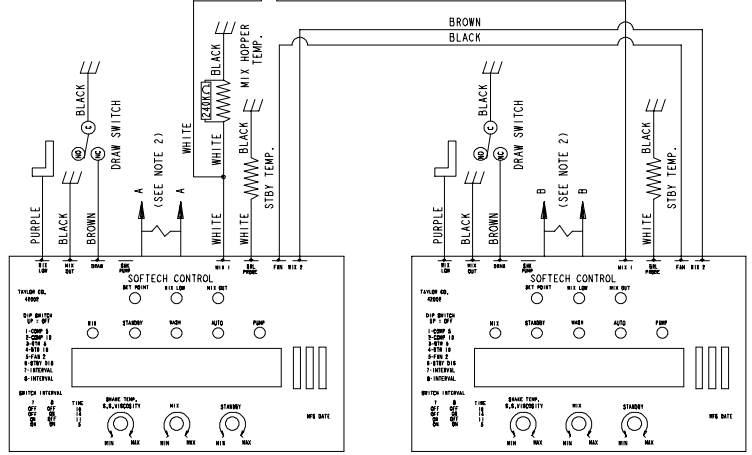

LEFT SIDE

RIGHT SIDE

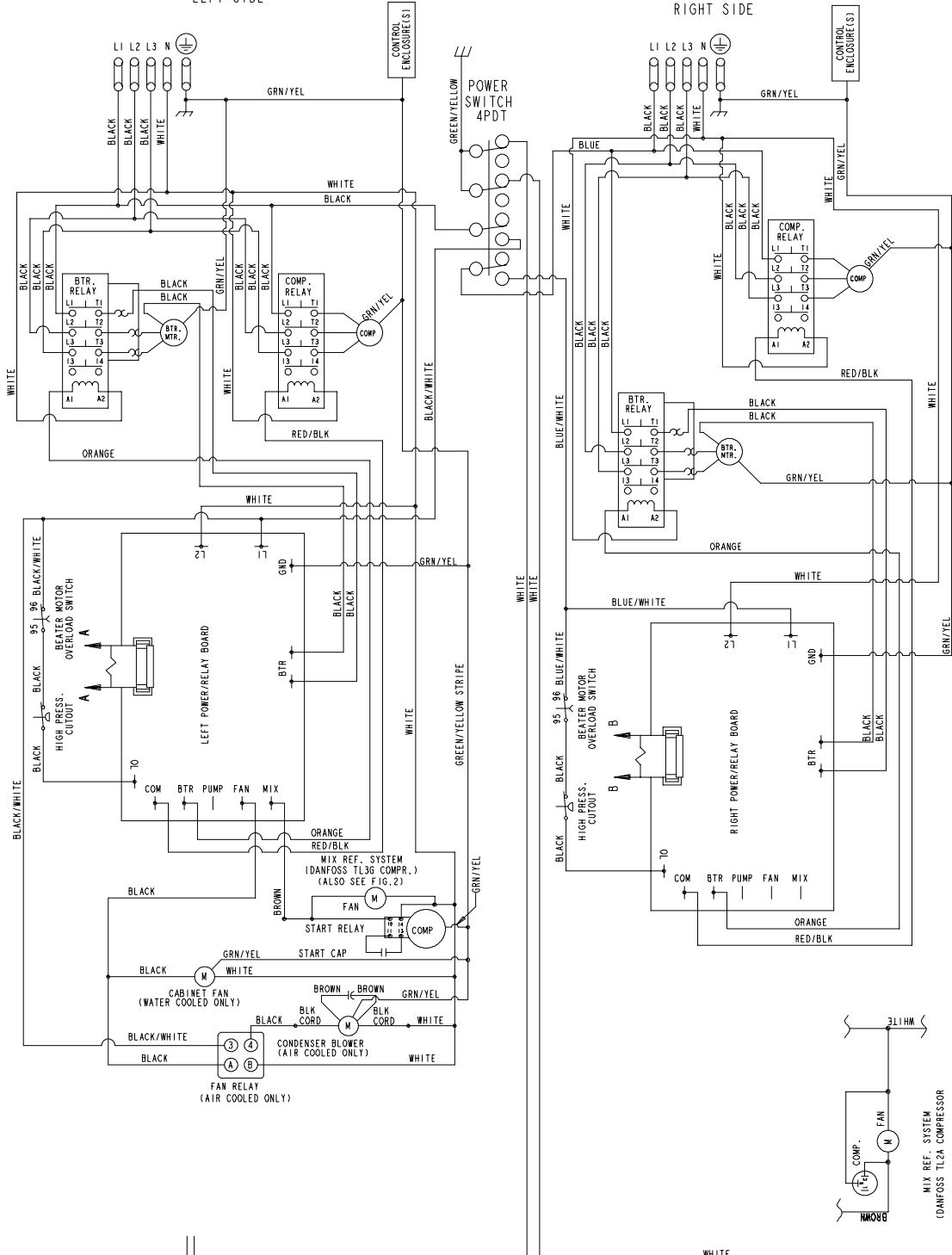

COMPRESSOR AND BEATER MOTOR PROTECTED UNDER PRIMARY 3 SINGLE PHASING CONDITIONS

GROUND FRAME SECURELY

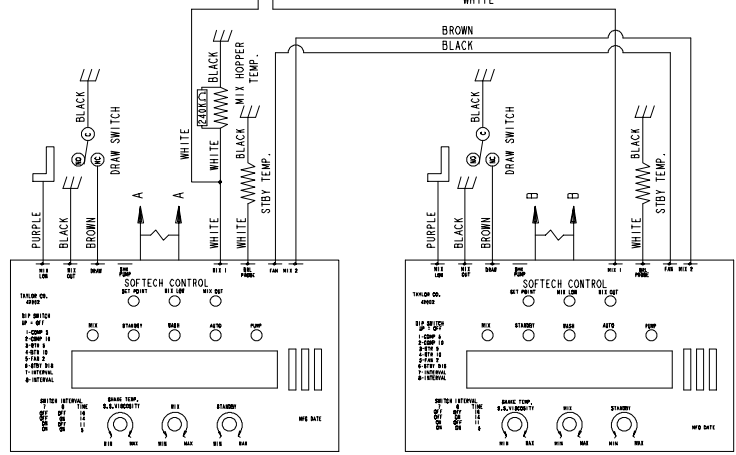

MIX REF. SYSTEM (DANFOSS TL3A COMPRESSOR) FIG. 1