

BAD BOY MOWERS



REBEL OUTLAW **ZERO-TURN MOWER** **OWNER'S, SERVICE & PARTS MANUAL**

For additional information, please see us at
www.badboymowers.com

Bad Boy, Inc.
102 Industrial Drive
Batesville, Arkansas 72501



TABLE OF CONTENTS

Basic Information	Section 1	Page 4
Bad Boy Safety Guidelines.....	Section 2	Page 5
Operation	Section 3	Page 9
Maintenance.....	Section 4	Page 10
Storage and Transportation.....	Section 5	Page 10
Troubleshooting and FAQ	Section 6	Page 12
Controls.....	Section 7	Page 13
Moving In-operable Mower.....	Section 8	Page 14
Instrumentation	Section 9	Page 14
Mower Blade Maintenance.....	Section 10	Page 15
Equipment Lubrication.....	Section 11	Page 15
How To Choose the Right Blade		Page 16
Mowing Tips.....		Page 17
Service Section		Page 18
Parts Section.....		Page 46
Limited Warranty		Page 70



BAD BOY MOWERS

THIS MANUAL APPLIES TO THE FOLLOWING EQUIPMENT:

BAD BOY REBEL SERIES

BRB 5400 54" 747cc Kohler Command	BRB 6100 61" 747cc Kohler Command
BRB 5400 54" 824cc Yamaha	BRB 6100 61" 824cc Yamaha
BRB 5400 54" 852cc Kawasaki FX	BRB 6100 61" 852cc Kawasaki FX
BRB 6100 61" 993cc Vanguard	BRB 7200 72" 993cc Vanguard
BRB 6100 61" 999cc Kawasaki FX	BRB 7200 72" 999cc Kawasaki FX

COMMONLY USED ITEMS AND PART NUMBERS

54" Blade	Hi-Lift Fusion 038-0001-00	Gator Blade 038-0003-00	Wave Blade 038-5220-00	
61" Blade	Hi-Lift Fusion 038-6080-00	Gator Blade 038-6081-00	Wave Blade 038-6090-00	
72" Blade	Hi-Lift Fusion 038-7230-00	Gator Blade 038-5400-00	Wave Blade 038-7215-00	
Hydraulic Filter	063-1070-00			
54" Deck Belt	041-1650-00			
61" Deck Belt	041-0178-00			
72" Deck Belt	041-0202-00			
Pump Belt	041-8050-00			
Oil Filter	Vanguard 993cc 063-8018-00	824cc Yamaha 015-0053-02	Kawasaki FX 063-8017-00	Kohler Command 063-5400-00
Air Filter	Inner Filter 063-8020-00		Outer Filter 063-8019-00	
Spark Plug	Vanguard 993cc 015-8000-00	Kawasaki FX 015-8001-00	Kohler Command 018-8000-00	824cc Yamaha 015-0053-06
Motor Oil	10W-30 Motor Oil - Bad Boy Synthetic Blend Motor Oil Recommended. (Approximately 2 Quarts) 085-6015-00			
Hydraulic Oil	20W-50 Motor Oil-Bad Boy Hydrostatic Oil Recommended (Approximately 2.5 Quarts/Transaxle) 085-6000-00			



SECTION 1: BASIC INFORMATION

Congratulations on the purchase of your new Bad Boy Mower! The purpose of this manual is to assist operators in maintaining and operating their machine. The information and instructions in this manual can help you attain years of performance from your new Bad Boy. Also, check out our website to learn more about the Bad Boy family.

- 1.1 All Bad Boy engines use 10W-30 engine oil. For maximum protection, Bad Boy synthetic blend engine oil is recommended.
- 1.2 All Bad Boy hydraulic systems use 20W-50 engine oil (Conventional or Synthetic). Bad Boy Hydrostatic oil is recommended.
- 1.3 All Bad Boy Mowers use hi-temp multi-purpose grease. NLGI No. 2 for the grease fittings.
- 1.4 Outlaw models have 12 psi in the front tires and 8 psi rear tires.
- 1.5 Most Briggs, Kohler, Kawasaki, and Vanguard engines hold approximately two (2) quarts of motor oil. Be careful not to over fill engine oil. Refer to engine's service manual.

WARRANTY REGISTRATION

The Warranty Registration form must be completed within 30 days to validate your warranty. As the new equipment owner, you are expected to see that the form is completed and forwarded to Bad Boy Inc. at time of delivery. Warranty is nontransferable. **Warranty registration should be completed by the selling dealership using the on-line registration site.**

MODEL/SERIAL NUMBER

Your Outlaw model serial numbers are found on the SIN plate underneath the seat. These numbers can assist you in the ordering of new parts when replacements become necessary.

PARTS/SERVICE

Only Bad Boy replacement parts are to be used on your mower. Replacement parts are available through your local Bad Boy Mowers Dealer. Remember to always provide the following information when ordering parts:

1. Correct part number
2. Correct serial number

All warranty repair and service must be handled through your authorized Bad Boy Mowers Dealer. To locate the nearest dealer, go to our website and click on Locate a Dealer.

EVAPORATIVE EMISSION CONTROL WARRANTY STATEMENT

Federal Evaporative Emission Control Warranty: Your Warranty Rights and Obligations

The Environmental Protection Agency (EPA), and Bad Boy Inc. are pleased to explain the evaporative emission control system's warranty on your 2019 equipment. New equipment that uses spark ignition engines for off-road use must meet stringent anti-smog standards. The evaporative emission control system on your equipment is designed, built, and equipped so it conforms at the time of sale to the ultimate purchaser with the requirements of 40 CFR 1060. The evaporative emission control system is free from defects in materials and workmanship that may keep it from meeting said requirements. Bad Boy Inc. must warrant the evaporative emission control system on your equipment for two years provided there has been no abuse, neglect, or improper maintenance. If an evaporative emission control system component does fail in a manner that would cause the equipment to no longer meet the requirements of 40 CFR 1060 within the first two years Bad Boy Inc. will replace the defective component. Your evaporative emission control system may include parts such as fuel tanks, fuel lines, carbon canisters, fuel caps, valves, vapor hoses, clamps, or connectors.



SECTION 2: MOWER SAFETY GUIDELINES

Never allow untrained people to operate this machine. It is the owner's responsibility to get training and see to it that anyone who has permission to use your machine receives the proper training. Do not mow around people. The factory discharge chute is designed to deflect debris downward, but it could be possible for debris to be thrown in a way that can cause damage to people or property. Seek additional training when possible to learn more about safety techniques and practices. **This cutting machine is capable of amputating hands and feet and throwing objects. Failure to observe the following safety instructions could result in serious injury or death.**

GENERAL OPERATION

- 2.1 Read, understand, and follow all instructions on the machine and in the manual before starting.
- 2.2 Do not put hands or feet near rotating parts or under the machine. Keep clear of the discharge opening at all times.
- 2.3 Always remain seated while operating the machine. If the machine is equipped with Roll Over Protection (ROPs), always buckle your seat belt.
- 2.4 Only allow responsible adults who are familiar with the instructions to operate this machine.
- 2.5 Clear the area of objects such as rocks, wire, toys etc., which could be thrown by the blades
- 2.6 Always maintain a safe distance from people and pets just prior to, and during, operation. Stop the machine if anyone enters the area.
- 2.7 Never carry passengers.
- 2.8 Do not mow in reverse unless absolutely necessary. Always look down and behind before and while backing.
- 2.9 Never direct discharged material toward anyone. Avoid discharging material against a wall or obstruction as material may ricochet back toward the operator. Stop the blades when crossing gravel surfaces.
- 2.10 Never operate the machine without the discharge chute, grass catcher, or other safety devices correctly in place and functioning properly.
- 2.11 Slow down before turning.
- 2.12 Always disengage blades, place steering controls in neutral, engage parking brake, and remove ignition key when leaving operators seat. Never leave a running machine unattended.
- 2.13 Disengage blades when not mowing. Shut off engine and wait for all parts to come to a complete stop before cleaning the machine, inspecting the machine for damage, removing the grass catcher, or unclogging the discharge guard.
- 2.14 Always operate machine in daylight or with adequate working lights.
- 2.15 Do not operate the machine while under the influence of alcohol or drugs.
- 2.16 Watch for traffic when operating near or crossing roadways.
- 2.17 Always wear eye protection when operating or servicing the machine.
- 2.18 Always wear ear protection, such as earplugs, while mowing.
- 2.19 Use extra care when loading or unloading the machine into a trailer or truck.
- 2.20 Be alert of surroundings. Watch for rocks, stumps, mounds, depressions, and low hanging limbs or objects that could be potentially hazardous while mowing.
- 2.21 Data indicates that operators 60 years of age and above are involved in a large percentage of riding mower related injuries. These operators should periodically evaluate their ability to operate the riding mower safely enough to protect themselves and others from serious injury.
- 2.22 Prevent fires by keeping engine and exhaust areas clear of grass clippings and other debris. Do not park or back mower over or immediately adjacent to flammable materials. Do not mow on or into piles of leaves. This may cause the leaves to become lodged around the engine and muffler and catch fire.



SETTING DECK HEIGHT

- 2.23 If your machine is equipped with an actuator motor, raise the deck using the raise /lower switch. Refer to section 7 (Controls). When deck is raised, set desired height with the deck height control dial, then lower deck with the raise / lower switch.
- 2.24 If your machine is equipped with a foot pedal, press foot pedal to raise deck, select your desired deck height with the deck height dial, then slowly release foot pedal.

SLOPE OPERATION

Slopes are a major factor related to loss of control and tip over accidents, which can result in severe injury or death. Operation on all slopes requires extra caution. If you cannot back up the slope, or you feel uneasy on it, do not mow it. Bad Boy Mowers recommends always evaluating the terrain and slope conditions prior to operating on or near a slope to ensure the mower is operated in a safe manner. Under proper conditions your Bad Boy Mower may be able to mow a maximum slope of 5 degrees transversely, across the slope, and a 10 degree slope if driving up the slope, and a maximum of 15 degrees if driving down the slope. Following are some general guidelines Bad Boy Mowers recommends following.

- 2.25 Mow up and down slopes, not across.
- 2.26 Watch for holes, ruts, bumps, rocks, or other hidden objects that tall grass can obscure. Uneven terrain could overturn the machine.
- 2.27 Choose a low ground speed when operating the machine on a slope.
- 2.28 Do not mow on wet grass, the tires may lose traction.
- 2.29 Do not attempt to coast down a slope in the neutral position.
- 2.30 Avoid starting, stopping, or turning on a slope. If the tires lose traction, disengage the blades and proceed slowly, straight down the slope.
- 2.31 Keep all movement on slopes slow and gradual. Sudden changes in speed or direction could cause the machine to roll over.
- 2.32 Use extra care while operating machine with grass catchers or other attachments: they can affect the stability of the machine. Do not use on steep slopes.
- 2.33 Do not try to stabilize the machine by putting your foot on the ground.
- 2.34 Do not mow near drop offs, ditches or embankments. The machine could suddenly roll over if a wheel goes over the edge or the edge caves in.
- 2.35 Be aware of what is located at the bottom of slopes. For example: rocks water, cliffs, and roadways.

CHILDREN

Tragic accidents can occur if the operator is not alert to the presence of children. Children are often attracted to the machine and the mowing activity. NEVER assume that children will remain where you last saw them.

- 2.36 Keep children out of the mowing area and in the watchful care of a responsible adult other than the operator.
- 2.37 Maintain Alertness and turn machine off if a child enters the area.
- 2.38 Before and while backing, look behind and down for small children.
- 2.39 Never carry children, even with blades shut off. They may fall off and be seriously injured or interfere with safe machine operation. Children who have been given rides in the past may suddenly appear in the mowing area for another ride and be run over or backed over by the machine.
- 2.40 Never allow children to operate the machine.
- 2.41 Never leave the key in the ignition, especially around children.
- 2.42 Use extreme care when approaching blind corners, shrubs, trees, or other objects that may block your view of a child



TOWING

Max. pulling weight: 500 lbs.

Max. at 5°: 440 lbs.

Max tongue weights: 54" = 75 lbs.; 61" = 80 lbs.; 72" = 90 lbs.

- 2.43 Tow only with a machine that has a hitch specifically designed for towing. Do not attach towed equipment except at the hitch point.
- 2.44 Follow the manufacturer's recommendation for weight limits for towed equipment and towing on slopes.
- 2.45 Never allow children or others in or on towed equipment.
- 2.46 On slopes, the weight of the towed equipment may cause loss of traction and loss of control.
- 2.47 Travel slowly and allow extra distance to stop.

SERVICE

SAFE HANDLING OF GASOLINE

To avoid personal injury or property damage, use extreme care in handling gasoline. Gasoline is extremely flammable and the vapors are explosive.

- 2.48 Extinguish all cigarettes, cigars, pipes, and all other sources of ignition.
- 2.49 Use only an approved gasoline container.
- 2.50 Never remove gas cap or add fuel with the engine running.
- 2.51 Allow engine to cool before refueling.**
- 2.52 Never fuel the machine indoors.
- 2.53 Do not store machine near open flame or source of ignition, such as a water heater or furnace.
- 2.54 Remove gas powered equipment from the truck or trailer and refuel it on the ground. If this is not possible, then refuel such equipment with a portable container, rather than from a gasoline dispenser nozzle.
- 2.55 Never fill gasoline containers inside a vehicle or on a truck or trailer bed with a plastic liner. Always place containers on the ground away from your vehicle before filling.
- 2.56 Keep the nozzle in contact with the rim of the fuel tank or container opening at all times until the fueling is complete. Do not use a nozzle lock-open device. Always allow any spilled fuel to completely dry before attempting to start the mower.
- 2.57 If fuel is spilled on clothing, change clothing immediately.
- 2.58 Never overfill fuel tank. Replace gas cap and tighten securely. **Tank is full when level reaches bottom of fill tube.**

GENERAL SERVICE

- 2.59 Never operate machine in a closed area where dangerous carbon monoxide fumes can collect.
- 2.60 Keep all nuts and bolts tight to be sure the equipment is in safe working condition. Never operate a poorly maintained machine.
- 2.61 Do not touch hot areas of the machine.
- 2.62 Never interfere with the intended function of a safety device or reduce the protection provided by a safety device. Check their proper operation regularly.
- 2.63 Keep the entire machine free of grass, leaves, or other debris build up. Clean up oil or fuel spillage and remove any fuel-soaked debris. Failure to do so can affect the safety and functionality of the machine, as well as increase the danger of a fire due to contact with the hot surfaces of the machine.
- 2.64 Allow machine to cool before storing.



- 2.65 If you strike something with the mower, turn the mower and blades off, engage the parking brake, and inspect the machine for damage. Repair, if necessary, before resuming.
- 2.66 Never make any adjustments or repairs with the engine running.
- 2.67 Check grass catcher components and the discharge guard frequently and replace with manufacturer's recommended parts, when necessary.
- 2.68 Mower blades are sharp. Wrap the blade or wear gloves before servicing them.
- 2.69 Check parking brake operation frequently. Adjust and service as required.
- 2.70 Maintain or replace safety and instruction labels, as necessary.
- 2.71 Do not attempt to mount a tire without the proper equipment and experience to perform the job.
- 2.72 Always maintain the correct tire pressure. Do not inflate the tires above the recommended pressure. Never weld or heat a wheel and tire assembly. The heat can cause an increase in air pressure resulting in a tire explosion. Welding can structurally weaken or deform the wheel.
- 2.73 Park machine on level ground. Never allow untrained personnel to service machine. Understand service procedure before doing work.
- 2.74 Mower deck, frame, and engine compartment should remain free of debris to prevent premature parts failures or fire hazards.

SAFETY INTERLOCK SYSTEM

Your Bad Boy mower is equipped with a safety interlock system. This system is designed to prevent serious injury or death to the operator and other people or property damage. The system consists of an operator presence switch in the seat, the parking brake, drive lever neutral position, the mower blade engagement switch, and the ignition switch. These interlocks are vitally important and must be tested frequently. Following are instructions to test these very important safety precautions. **Note: the operator must be seated properly on the machine during these tests and the engine should have been previously allowed to warm to operating temperature.**

- 2.75 With the parking brake engaged, bring lever arms to their inward position. Attempt to start the machine with the blade actuator in off position. The engine should not start.
- 2.76 On a level surface, disengage the parking brake and place lever arms to their outward position. Then, attempt to start the machine with the blade actuator in off position. The engine should not start.
- 2.77 Engage parking brake and leave lever arms in outward position. Put blade actuator in the on position, then attempt to start the machine. The engine should not start.
- 2.78 Next, start the engine as stated in the Mower Operation Section. Disengage parking brake and, Very Slowly, begin to rise from the seat. The engine should stop.

If any of these tests fail to produce the results indicated and the problem cannot be identified, contact your Bad Boy Mower dealer or the support contacts in the rear of this manual.

ROLL OVER PROTECTION STRUCTURES (ROPS)

This machine is equipped with ROPS from the factory. It is vital that the rules below are adhered to. ROPS, when used correctly, dramatically decrease the fatality rate in roll-over instances.

- 2.79 Periodically ensure the bolts that attach the ROPS to the machine are securely fastened.
- 2.80 Always operate the machine with the ROPS secured in the upright position.
- 2.81 If the surrounding environment (e.g. low-lying limbs, signage, etc.) makes it impossible to mow with the ROPS upright, lower the ROPS at the hinge point, mow the area, then immediately secure the ROPS upright.
- 2.82 Upright ROPS are taller than the operator's head. Be aware of this and your surrounding environment, as referenced above. The mower and operator may clear low-lying items, but the ROPS may not.
- 2.83 Always wear the provided seat belt when ROPS are utilized. Failure to use the seat belt severely handicaps the safety benefits of the ROPS.
- 2.84 In the event of a roll-over, replace the ROPS before resuming use of the machine.



SECTION 3: MOWER OPERATION

Never operate the machine with faulty equipment. Always be alert of sudden changes in landscape, as the mower will react differently on slopes or embankments than it will on flat surfaces. Never operate the mower with the discharge chute open. Do not cross terrain, other than grass, with blades turning. This could cause damage to property or bystanders.

- 3.1 Place parking brake in up position.
- 3.2 Drive arms must be in the "open" position. While sitting on the machine, each arm is positioned away from the operator, to the right and left. Drive arms will lock into place and must be in this position to start machine.
- 3.3 Put PTO switch in the OFF position.
- 3.4 If your machine has been equipped with a ROPS (Roll Over Protection System) then you must fasten seatbelt.
- 3.5 If machine has not been started recently, engage the choke.
- 3.6 Make sure nothing is under or around machine.
- 3.7 Place key in ignition and turn.
- 3.8 Once machine is started, disengage the choke.
- 3.9 Increase RPM by sliding the throttle to fast position, toward the rabbit.
- 3.10 Owners must become familiar with the controls before operating a zero-turn radius vehicle.
- 3.11 Start slowly and build your skill level. Have ample practice before using the machine at full capabilities.
- 3.12 Be comfortable with machine before engaging blades. Know what each component controls before using machine.
- 3.13 Your mower will perform differently on an incline /decline. Be cautious, slow down, and do not make any sudden jerking movements with control arms. The machine could lose traction on a decline or tip backwards on an incline.
- 3.14 Once you become comfortable with your Bad Boy Mower you will notice your overall mowing time will decrease.
- 3.15 Always engage PTO at full throttle.
- 3.16 Start engine with throttle position between half and full throttle.

***Avoid operating your mower on side hills of over 5 degrees,
inclines of over 10 degrees,
and declines of over 15 degrees.***



BAD BOY MOWERS

SECTION 4: MOWER MAINTENANCE

Maintenance	Interval					Section
	Daily	First 8 Hours	Every 50 Hours or Annually*	Every 100 Hours or Annually*	Every 250 Hours	
Check and add engine oil	●					Section 3
Check all belts for proper alignment	●					Section 2 (Pump) 6 (Deck)
Check tire pressure and wheel lug nuts	●					Section 5
Check battery terminal connections	●					Section 4
Check condition of blades	●					Section 6
Check for fuel and oil leakage	●					Section 3
Check deck and engine compartment for debris and clean as necessary	●					
Check air filters	●					
Initial oil change		●				Section 3
Tighten nuts and screws			●			
Change engine oil and filter			●			Section 3
Initial change of hydraulic oil and filter			●			Section 1
Grease mower				●		Section 5
Replace air element and pre-cleaner [♦]				●		Section 3
Replace fuel filter [♦]				●		Section 3
Clean or replace spark plugs and set gap				●		Section 3
Change hydraulic oil and filter					●	Section 1
Clean combustion chamber ^{Dealer}					●	
Check and adjust valve clearance ^{Dealer}					●	
Clean and lap valve seating surface ^{Dealer}					●	

*Maintenance by hour or annually whichever comes first

♦Check air and fuel filter more often in dusty conditions

^{Dealer}Get maintenance performed at a registered dealership

SECTION 5: MOWER STORAGE & TRANSPORTATION

- 5.1 Keep machine from collecting debris by storing in a covered area while not in use.
- 5.2 Fuel can harm your machine if left for more than 30 days without changing, especially if the fuel contains ethanol. Never use fuel with more than 10% ethanol by volume. E-15 is not permitted.
- 5.3 Disconnect the negative battery cable when machine will be stored for more than 30 days.
- 5.4 Always secure machine properly when transporting machine.
- 5.5 Do not load machine on trailer with blades engaged.
- 5.6 Do not use ramps to load the machine.
- 5.7 Make sure Parking Brake is in "up" position.
- 5.8 In wet conditions tires may spin while loading / unloading. If necessary, wait for dry conditions before loading/unloading.
- 5.9 Make sure mode of transportation is suitable to bear the weight of mower.
- 5.10 Deck height should be set at maximum before attempting to load.
- 5.11 Secure mower with at least two straps capable of securing weight of mower.
- 5.12 Always ensure mower engine and exhaust has cooled prior to parking inside building.



SECTION 6: TROUBLESHOOTING

6.1 **Q: How do I prevent an uneven cutting pattern and increase the quality of cut?**

A: Check tire pressure, check blade sharpness (replace blades or sharpen at least once per year or when needed), make sure blades are tightened properly, check spring and belt tension, check the underside of the deck to ensure the mower deck is free of grass build-up and debris, make sure your machine is at full throttle, and vary your mowing pattern each time you cut your grass.

6.2 **Q: What should I do if my mower won't start?**

A: Check battery charge and connection (grounds), check your fuel (make sure fuel is less than 30 days old and contains no water), make sure your spark plug is in good condition and spark plug wire is attached, and make sure air filter is clean (a dirty filter makes it more difficult for the engine to draw air). Check the integrity of the 25-amp main fuse; also check for any bare wires and/or bad connections.

6.3 **Q: What should I do if the blades won't engage?**

A: Make sure the safety switch is plugged in on the bottom of seat. Check the underside of the PTO engager to ensure the plug is secure at switch. Also check PTO fuse underneath operator console (10-amps)

6.4 **Q: What type of fuel is recommended for my mower?**

A: We recommend that you use a name brand fuel to ensure quality. Use fuel with an octane rating near 87. Higher octane fuels offer no benefit. Only fuels with an ethanol content of 10% or less may be used. By law, E-15 fuel is not permitted. Usage of E-15 will result in premature engine failure.

6.5 **Q: Do you offer touch-up paint for your mowers?**

A: Touch-up paint is available. Contact your local dealer for more information.

6.6 **Q: How do I clean my mower?**

A: It is recommended that you use an air hose or blower to remove dust and debris from the mower, to ensure there is not a buildup of grass on the mower deck and engine compartment, which could become a fire hazard. If you must wash the mower, ensure you run the engine to operating temp to dry water and engage the blades to spin off any standing water on the pulleys. Avoid spraying water onto electrical components and bearings, to prevent premature failure of these parts.



BAD BOY MOWERS

SECTION 7: CONTROLS

- 7.1 **Ignition Switch:** Bad Boy mowers have a three-position ignition switch: off, run, and start. With key inserted, rotate it clockwise to START position and release key when engine starts, and switch will automatically return to the RUN position.
- 7.2 **Throttle Control:** A cable is connected to the engine throttle for controlling engine speed. Move lever forward to increase engine rpm, move lever backward to decrease engine rpm.
- 7.3 **Choke Control:** The choke control, located to the right of the operator's left, is a 'push-pull' type. When the choke knob is pushed in, the choke is in the off (run) position. When the choke is pulled out it is in the on (start) position. **Do not operate the machine in the on (start) position.**
- 7.4 **Control Levers:** These levers control the mower's speed, direction, and neutral lock. These levers are used to steer, accelerate, decelerate and change direction.
- 7.5 **Blade Engage Switch:** This switch engages the blades. Pull the switch up to engage the blades and push the switch down to disengage the blades.
- 7.6 **Parking Brake:** This lever engages the parking brake. Pull back fully to engage the parking brake; push forward to disengage.
- 7.7 **USB Charging Port:** Your mower is equipped with a USB charging port for your accessory needs.
- 7.8 **Deck Height Control:** The deck height dial is used to set the cut of the deck.

- 7.9 **Deck Travel Lock:** The deck travel lock holds the deck in a transport position.

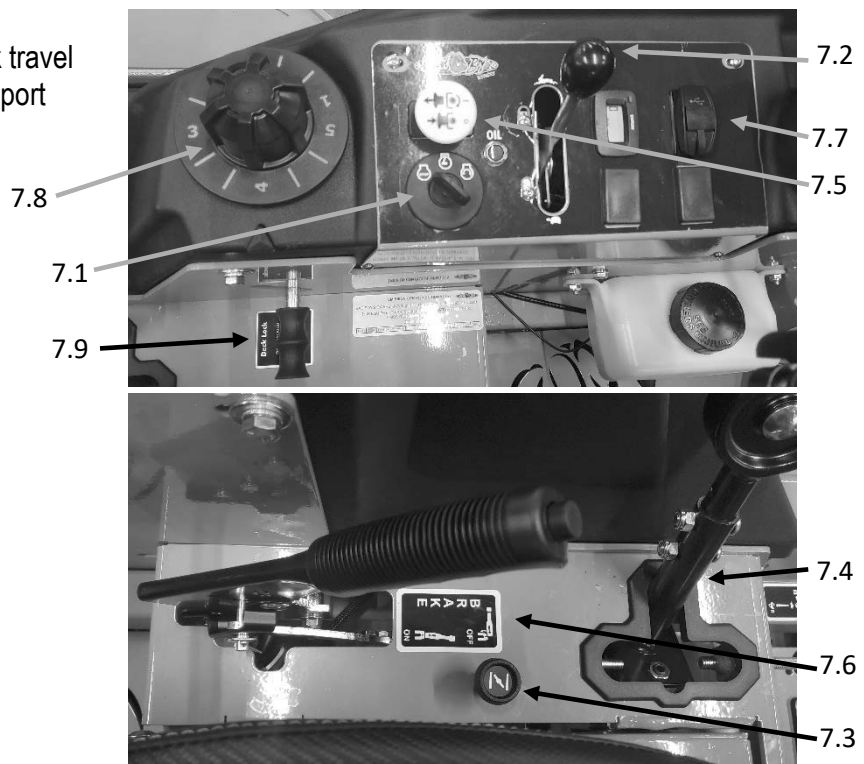



BAD BOY MOWERS

SECTION 8: MOVING INOPERABLE MOWER

- 8.1 Do not tow machine. Use a winch to load on a trailer for transporting.
- 8.2 If it becomes necessary to move an inoperable mower, the drive transaxles are equipped with bypass valves that allow the drive tires to rotate freely. These bypass valves are located on top of the REBEL's transaxles. Each require a quarter turn to allow for proper bypass.

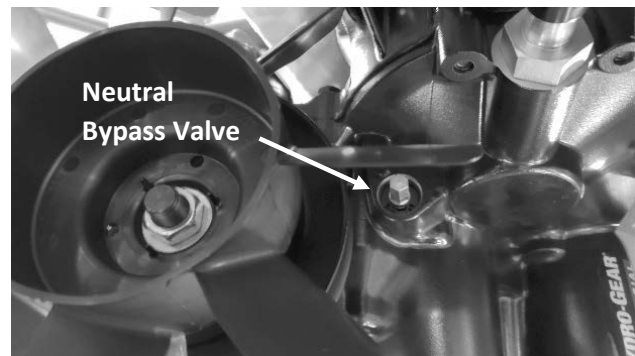
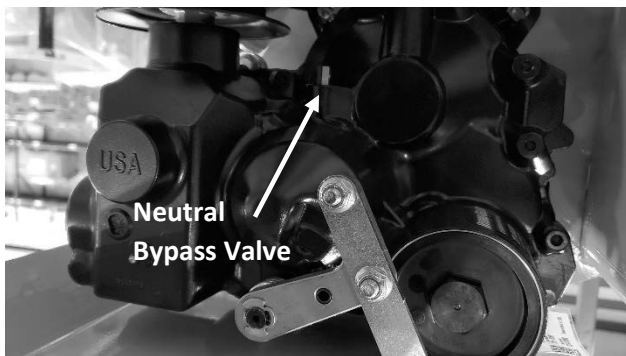
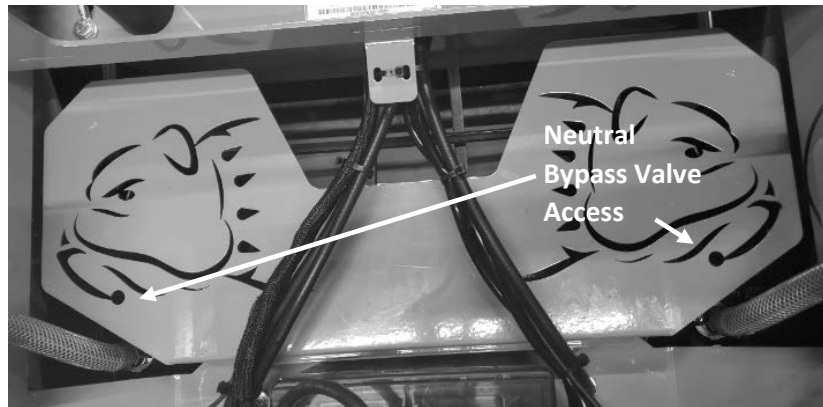

Your Bad Boy Mower Weighs: **REBEL SERIES: 1180-1310 lbs.**

****Weights fluctuate with the addition of accessories.*

- 8.3 As you can see by the weights of the machines, you shouldn't ever try to push or pull a Bad Boy Mower by hand. This could cause serious bodily injury.
- 8.4 Hopefully, you'll never need to use this section of the manual. However, if you do, use extreme caution when moving machine!

SECTION 9: INSTRUMENTATION

- 9.1 **Electronic Hour Meter:** Registers Hour increments up to 9,999.9 total hours. This meter records the cumulative time the engine is running.
- 9.2 **Oil Light:** Alerts the user of a low oil level situation when lit.



SECTION 10: MOWER BLADE MAINTENANCE

- 10.1 Check mower blades after each use. This is essential for maintaining well-groomed turf. Keep the blades sharp. If a dull blade is used for cutting, the grass will tear rather than cut. This could damage the grass leaving a brown frayed top on the grass within a few hours. A dull blade will also require more power from the engine.
- 10.2 NEVER attempt to straighten a bent blade by heating. NEVER attempt to weld a cracked blade. The blades can break and cause serious injury or death.
- 10.3 NEVER work with blades while engine is running or deck clutch is engaged.
- 10.4 ALWAYS place deck clutch in DISENGAGE position while performing maintenance.
- 10.5 Use blocks when you MUST work under mower.
- 10.6 ALWAYS wear thick gloves when handling blades.
- 10.7 ALWAYS check for blade damage if mower strikes rock, branch, or other objects that could potentially damage the blade.

***(REMEMBER: NEVER CHECK BLADE WHILE ENGINE IS ON!
NEVER CHECK BLADES WHILE BLADES ARE ENGAGED!)***

SECTION 11: EQUIPMENT LUBRICATION

- 11.1 Park the machine on a level surface and disengage the blade control switch.
- 11.2 Move the motion control levers outward to the neutral position, engage parking brake, stop the engine, remove the key, and wait for all moving parts to stop before leaving the operating position.
- 11.3 Grease Type: NLGI grade #2 multi-purpose gun grease.
- 11.4 Clean the grease fittings with a cloth. Scrape any paint off the front of the fitting(s).
- 11.5 Connect a grease gun to each fitting. Pump grease into the fitting until grease seepage is observed. Be mindful of over-pressurization. Do not force the lever arm if there is strong back pressure as this can lead to reduced life of the component(s). Wipe up excess grease.
- 11.6 Refer to service manual section for grease fitting locations.



HOW TO CHOOSE THE RIGHT BLADE

Essentially there are only TWO basic styles of mowing blades used or approved for use on our current products:

1. The standard style of mowing blade is essentially designed for cutting grass and effectively discharging the clippings out from the deck to fall onto the lawn or to be captured in a grass collection system. Standard blades are also referred to as “2-in-1” (discharging & bagging) or “high-lift” blades (because they are designed to create a higher-lifting airflow).
2. Mulching blades generally have a more curved style surface and frequently include extra cutting surfaces along the blade edges. These blades may also come in a “+” design (which is actually two individual blades arranged in a perpendicular fashion to enhance mulching). The “+” blades are usually found on older style mowers; newer ones utilize blades with more advanced mulching technology. Mulching blades may also be referred to as “3-in-1” (mulching, discharging & bagging) or “all-purpose” blades.

Bear in mind that the re-circulating airflow design of 3/1 blades makes them less efficient at discharging grass clippings than a standard 2/1 blade. As with most all-purpose tools, there is some give and take as opposed to using a tool designed for a more specific purpose.

If you’re experiencing less-than-desired cutting or discharging performance with a 3/1 blade, you may want to check into using a 2/1 blade. Conversely, if you’re using a 2/1 blade and want to mulch clippings, you should see about the availability of mulching blades or a mulching kit. *

The type of blade installed on a new mower is a decision the retailer makes for each model of mower, based on the expected needs of most customers. If you’re unsure of which blade is on a particular model, inspect the blade. Blades have part numbers stamped into them. Then compare these part numbers with the unit’s Operator’s Manual or Parts List.

It is true there are many other styles of blades available. But since we don’t manufacture or recommend using these other aftermarket styles, we will leave them out of this discussion. Should you want more information on special application or aftermarket blades, you should contact the companies that make these products. NOTE: Customers using non-OEM blades do so at their own risk. The use of unapproved (non-OEM) blades may void any or all of the mower and engine factory warranties.

* **MULCHING KITS** – These generally consist of mulching blades and a mulching plug (which closes off the discharge opening to keep the clippings contained under the deck for re-cutting) plus any necessary hardware for installation. Please check with your parts distributor regarding the contents of a particular mulching kit.



MOWING TIPS:

- Mow header strips at the ends of the lawn and around flower beds first. Make them wide enough that you can turn the mower around in the already mown section. Then mow back and forth between these header strips overlapping each lap by about 1/8 the width of the mower's deck.
- Don't cut your grass too short, particular for cool season grasses. Higher heights usually provide for a deeper root system, looks better, and is less likely to have weeds invading, particularly crabgrass.
- Don't remove any more than one third of the grass leaf at any one cutting. If circumstances arise that a lawn gets too tall and you just have to lop off a bunch to get caught up, bite the bullet and break it down into several mowings to get caught up with 3 or so days between cuttings.
- NEVER SCALP YOUR LAWN.** Scalping severely damages the root system to such a degree that it may die.
- Avoid mowing when the grass is wet or when it's dark
- Avoid throwing grass clippings into the street and driveway where they can be washed into the sewer system. After mowing, clean up driveway and walkways.
- When mowing remove only a third with each cutting (except for the first mowing of the season when it's ok to remove more). You can safely leave clippings that will quickly decompose and add nutrients back into the soil. Contrary to popular opinion, grass clippings do not add to thatch buildup. Grass blades are made up of about 75% water.
- Mow your lawn in a different direction with each mowing, especially with lawns of shorter grass types. Altering the direction ensures a more even cut since grass blades will grow more erect and less likely to develop into a set pattern.
- Keep your mower's blade sharp, which means having it sharpened several times during the mowing season. Keep several blades around so you'll always have a sharp one on hand. Sharp blades cut the grass cleanly and help mulch clippings into small pieces which break down quickly.
- Don't forget to change your mower's oil at least once during the mowing season. For brand new mowers, change the oil after about 5 hours of operation during the initial break-in period.
- At the end of the mowing season use a fuel stabilizer in the remaining gasoline
- In the spring, don't use that old gas unless you properly used a fuel stabilizer, it can cause a number of problems. Better to use fresh gasoline to begin the new mowing season.
- Leaf blade A** demonstrates what a leaf blade should look like after mowing with a sharp blade.
- Leaf blade B** demonstrates a leaf blade that was injured by a dull mower blade.
- Leaf blade C** was cut by the mower but indicates that the mower blade is not sharp enough. The shredded white tissue protruding from the leaf blades C and D is the vascular tissue of the plant.
- Leaf blade D** has been mown for quite some time with a dull mower blade. The leading edge of the blade enclosure is equipped with an adjustable guard. When the guard is set to a higher position, it allows incoming grass to remain in a more upright position just prior to being cut. The result is a higher quality cut,

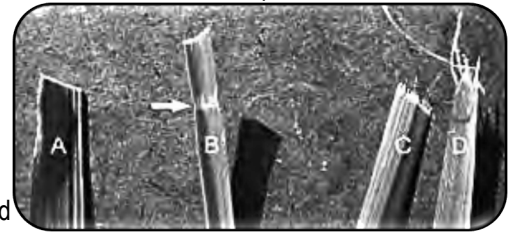

TO BAG OR TO MULCH?

Grass clippings do not contribute to thatch buildup or increase the chances of disease. If you mow your lawn at the right height, without removing any more than 1/3 of its total height, clippings will quickly breakdown without a trace. These clippings contribute additional nitrogen and other nutrients to the soil and supply it with additional organic materials. Clippings from a 1000 sq. ft. lawn can add as much as 1 - 2 pounds of nitrogen back into the soil. If you have a compost pile, then you may want to bag your clippings occasionally to add much needed green-matter to the compost pile. Make sure it is mixed thoroughly with brown matter to avoid a strong ammonia odor. **DO NOT COMPOST CLIPPINGS** after applying any weed control or weed-feed type product. Before adding clippings to the compost pile wait at least 3 mowings after these products have been applied.



SERVICE SECTION

SECTION 1: HYDROSTATIC SYSTEM

The hydro reservoir tank on the Outlaw Rebel model is located just behind the seat, on each side of the frame. Notice the “full cold” line at the bottom of the tank. Use only 20W-50 motor oil in this tank. Conventional or synthetic oil may be used.

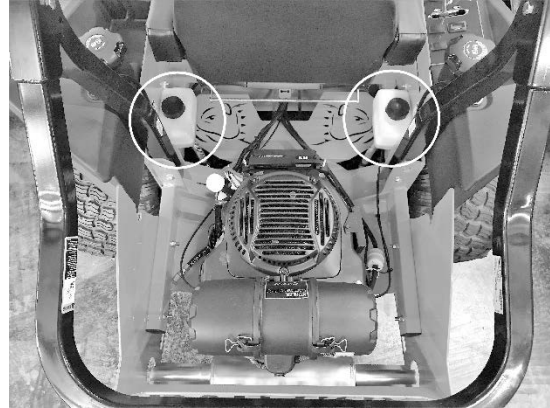

THE FOLLOWING MAINTENANCE IS TO BE PERFORMED ON A LEVEL SURFACE.

Outlaw Rebel transaxles hold 4 quarts of 20W-50 motor oil each. Bad Boy Hydrostatic Oil is recommended. Transaxle service is recommended after the first 75 hours of use; then at intervals of 250 usage hours. Use only Hydro-Gear® brand oil filters. Use of other brands could void the warranty.



CHANGING YOUR HYDRAULIC OIL AND FILTER

HYDRO-GEAR 4400 TRANSAXLE

1. Place an oil drain pan (12” or more in diameter and 8 qt. capacity is optimal) beneath the oil filter. Remove the oil filter cover from the transaxle to drain the oil. Remove the O-ring from the cover and discard the O-ring.
2. After the oil has drained from the transaxle, remove the oil filter from the transaxle housing.
3. Install a new filter and a new O-ring onto the filter cover and install the filter cover. Torque the filter cover to 200-300 in-lbs.
4. Fill the transaxle with new 20W-50 motor oil through the hydraulic reservoir until it reaches the cold fill line on the tank.
5. Drain the old oil filter of all free-flowing oil prior to disposal. Place used oil in appropriate containers and deliver to an approved recycling collection facility.
6. Proceed to the purge procedure.

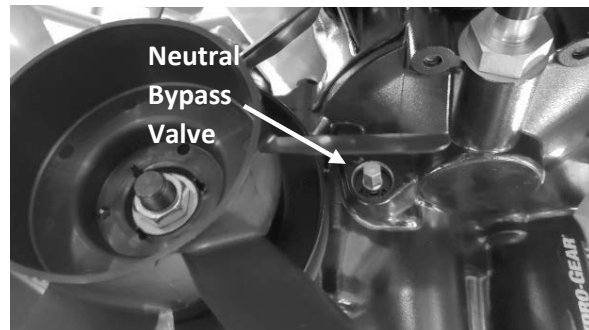
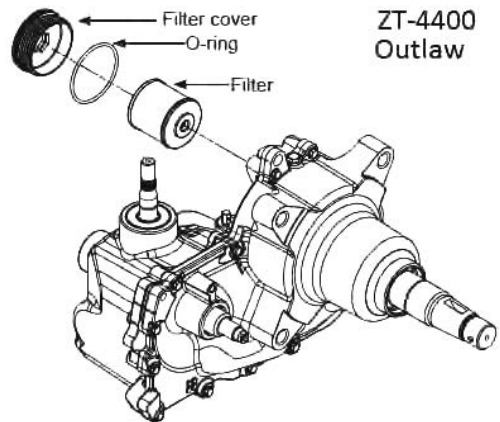

PURGING PROCEDURE

Due to the effects air has on the efficiency in hydrostatic drive applications, it is critical that the air is purged from the system. These purge procedures should be implemented any time a hydrostatic system has been opened to facilitate maintenance or any additional oil has been added to the system.

1. Lift the rear tires of the mower off of the ground and chock your front tires so they do not move.
2. With the bypass valve open and the engine running, slowly move the directional drive arms in the forward and reverse directions (5 to 6 times), as air is purged from the unit, the oil level will drop.
3. With the bypass valve closed and the engine running, slowly move the directional drive arms in the forward and reverse directions (5 to 6 times). Check the oil level, and add oil as required after stopping the engine.
4. It may be necessary to repeat steps 1 and 2 until all the air is completely purged from the system. When the transaxle moves forward and reverse at normal speed purging is complete.

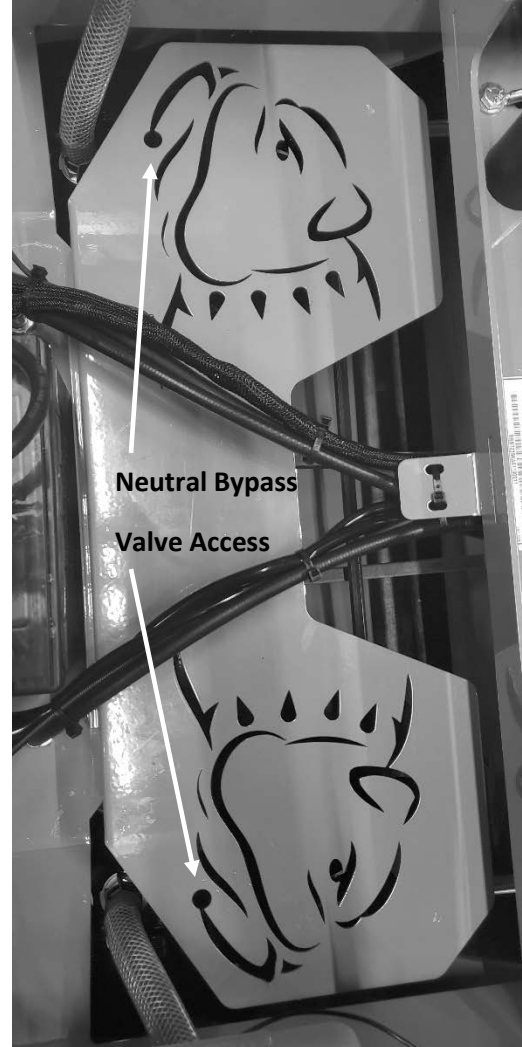

To adjust the tracking on the mower, lengthen or shorten the push rods shown in the picture to the right. Lengthening the push rod will increase the speed of the pump. Shortening the push rod will decrease the speed of the pump. On-the-fly adjustments can be made by turning the adjustment knob in front of either steering arm until the desired effect is achieved.

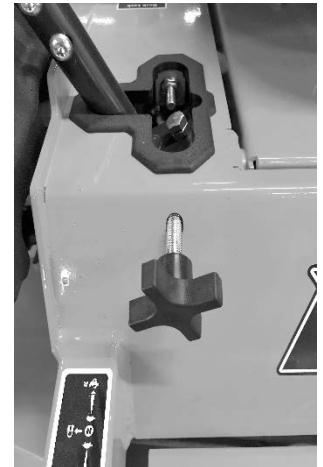



BAD BOY MOWERS

SECTION 2: DRIVE BELT

Shown on the right is the tensioner for your pump belt. Adjusting this will either increase or decrease tension on the belt. Use a 3/4" wrench to loosen the jam nuts and either tighten for more belt tension or loosen for less belt tension.



The tension should be adjusted so that there is between 60 to 65 lbs. of tension on the belt. This can be checked with a belt tension gauge as shown to the right.

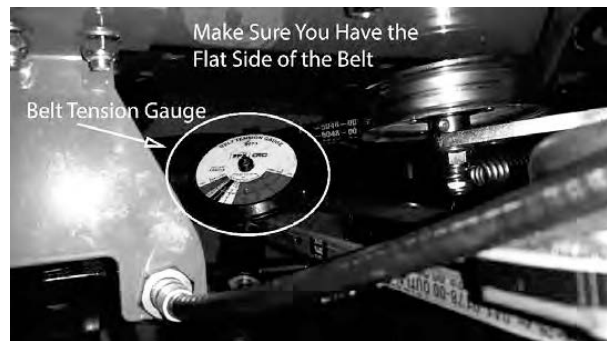

Use a belt tension gauge to ensure the proper tension. Your or service center will have a belt tension gauge or you can buy one (Part Number 041-9999-00).





BAD BOY MOWERS

SECTION 3: ENGINE

KOHLER Command 747CC

This machine has an oil drain hose installed on the engine to allow for easier oil changes. Bad Boy recommends that the oil and filter be changed after the initial 8hrs. of use, and at intervals of 50 usage hours or yearly, whichever occurs first after that. Please refer to the engine owner's manual for oil capacity. Bad Boy 10W-30 synthetic blend engine oil is recommended for maximum protection.

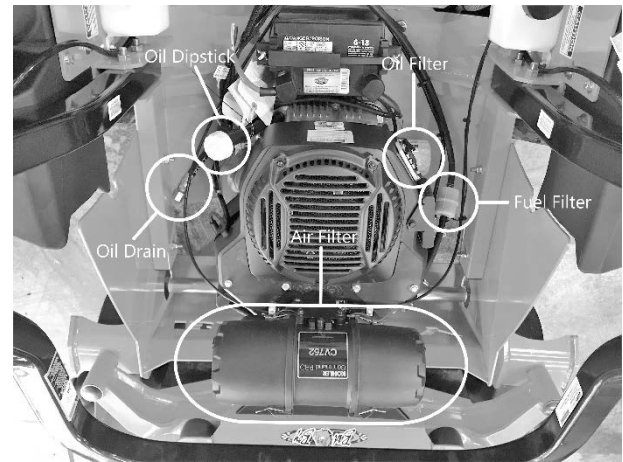

CHANGING YOUR ENGINE OIL AND OIL FILTER

1. Remove oil dipstick and open oil drain. Allow oil to completely drain. (Make sure to have an oil pan ready to capture old oil and properly dispose old oil.)
2. The oil filter is located on the right side of the engine. Clean area around oil filter. Place a container under the oil filter to capture any oil and remove filter. Wipe off mounting surface and reinstall drain plug. Torque to 10 ft.*lbs.
3. Place new filter in shallow pan with open end up. Fill with new oil until oil reaches the bottom of the threads. Allow two minutes for oil to be absorbed by filter material.
4. Apply a thin film of clean oil to rubber gasket on new filter.
5. Refer to instruction on oil filter for proper installation.
6. Fill crankcase with approximately 2 quarts of new oil. Level should reach top of indicator on dipstick.
7. Reinstall oil filter dipstick and tighten securely.
8. Start engine; check for oil leaks. Stop Engine; correct oil leaks. Recheck oil level.
9. Dispose of used oil and filter in accordance with local ordinances.

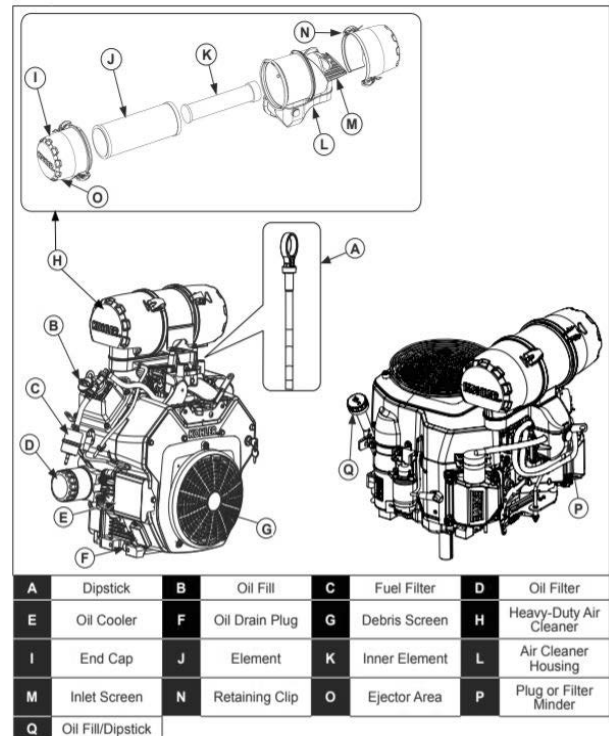



BAD BOY MOWERS

KOHLER Command 747CC (CONTINUED)

Replace the filter yearly. Prior to the removal of the old filter, note the direction of fuel flow as indicated on the filter. Have towels readily available in order to quickly remove any fuel leakage. Always use new hose clamps and ensure the security of the new filter by lightly pulling on each hose. Always perform maintenance outdoors or in a well-ventilated area. Do not smoke or allow any open flames in the vicinity of any maintenance activities.

CHANGING YOUR FUEL FILTER

1. Locate your fuel filter and mark the direction it is facing.
2. Clamp each side of the fuel filter to minimize any gas spills.
3. Remove the clips from each side of the fuel filter and remove the fuel filter.
4. Place the new fuel filter in the same direction as the old and place clips back into place.
5. Remove clamps.

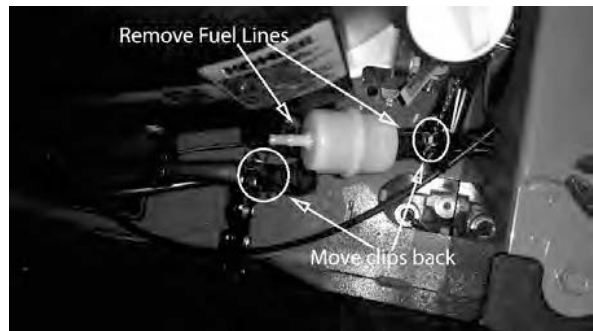
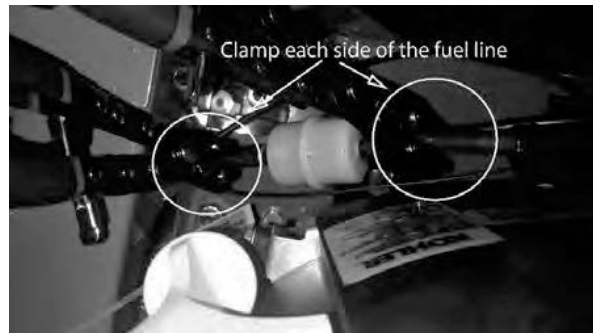



BAD BOY MOWERS

KOHLER Command 747 CC (CONTINUED)

The air cleaner is the engine's only defense against damaging foreign particles. It is very important that the air cleaner element is inspected prior to each use. Remove the element and tap its sides in order to remove debris. Do not blow the filter out using compressed air. Doing so will greatly reduce the air cleaner's effectiveness. Replace yearly; more often in dusty environments. Adhering to these practices will help prevent loss of power and premature engine failure.

CHANGING THE AIR CLEANER

1. Locate the air filter and unbuckle both of the air filter cover latches.
2. Remove the cover and take out the outer white element and the inner blue element.
3. Clean or replace elements.
4. Reattach the cover making sure the air intake is facing down.

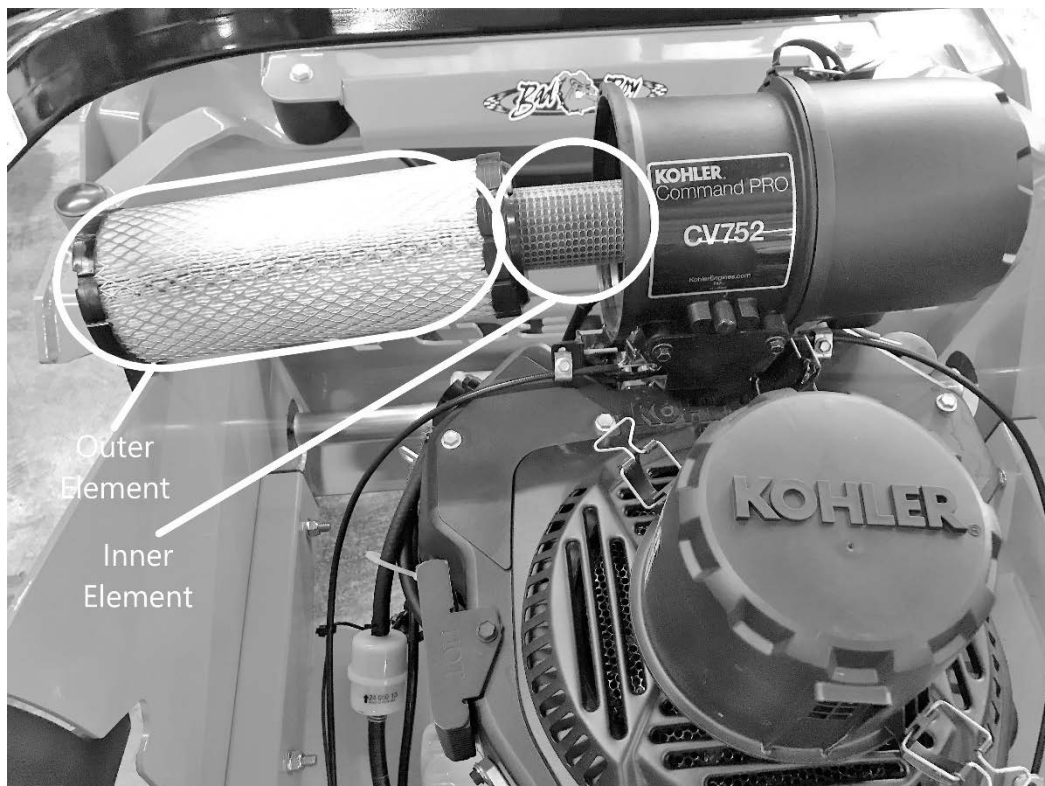
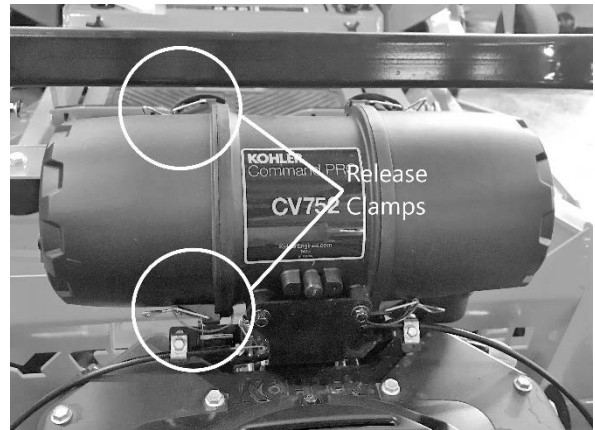



BAD BOY MOWERS

KOHLER Command 747CC (CONTINUED)

CHANGING THE SPARK PLUGS AND CHECKING THE SPARK PLUG GAP

1. Remove the wire on the spark plug and use a 5/8" socket to remove the spark plug.
2. Check the gap on the spark plug to verify that it is 0.03 in using a feeler gauge.
3. If the spark plug is worn, overheated, wet or carbon fouled replace the spark plug.
4. Install the plug into cylinder head and torque to 20 ft.-lbs. Be careful not to overtighten the spark plug.

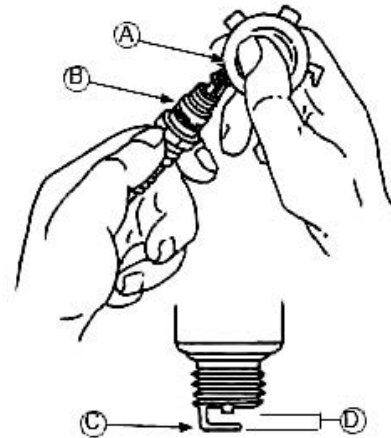
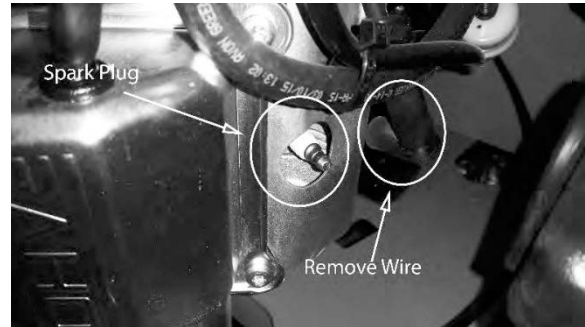

A	Wire Gauge	B	Spark Plug
C	Ground Electrode	D	Gap



KAWASAKI FX850V

This machine has an oil drain hose installed on the engine to allow for easier oil changes. Bad Boy recommends that the oil and filter be changed after the initial 8 hrs. of use, and at intervals of 50 usage hours or yearly, whichever occurs first after that. The oil capacity is 2 quarts. Bad Boy 10W-30 synthetic blend engine oil is recommended for maximum protection.

CHANGING YOUR ENGINE OIL AND OIL FILTER

1. Remove oil dipstick and open oil drain. Allow oil to completely drain. (Make sure to have an oil pan ready to capture old oil and properly dispose old oil.)
2. The oil filter is located on the right side of the engine. Clean area around oil filter. Place a container under the oil filter to capture any oil and remove filter. Wipe off mounting surface and reinstall drain plug. Torque to 10 ft*lb.
3. Place new filter in shallow pan with open end up. Fill with new oil until oil reaches the bottom of the threads. Allow 2 minutes for oil to be absorbed by filter material.
4. Apply a thin film of clean oil to rubber gasket on new filter
5. Refer to instructions on oil filter for proper installation.
6. Fill crankcase with approximately 2 quarts of new oil. Level should top of indicator on dipstick.
7. Reinstall oil fill/dipstick and tighten securely.
8. Start engine; check for oil leaks. Stop Engine; correct oil leaks. Recheck oil level
9. Dispose of used oil and filter in accordance with local ordinances.

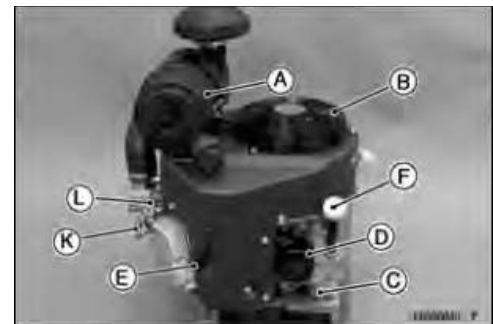
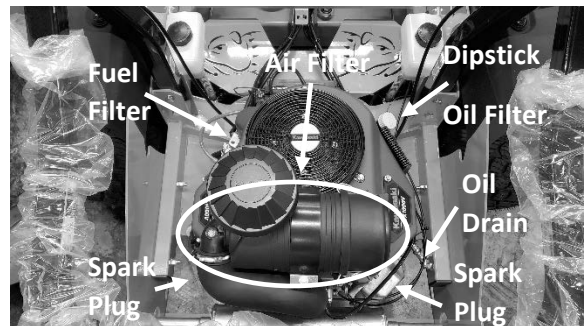

A. Air Cleaner
B. Air Inlet Guard
C. Oil Drain Plug
D. Oil Filter
E. Spark Plugs/Spark Plug Caps
F. Oil Gauge
K. Control Panel
L. Carburetor



G. Fuel Pump
H. Fuel Filter
I. Electric Starter
J. Voltage Regulator

KAWASAKI FX850V (CONTINUED)

The fuel filter is located in the fuel line on the left side of the engine by the starter motor. Replace the filter yearly. Prior to the removal of the old filter, note the direction of fuel flow as indicated on the filter. Have towels readily available in order to quickly remove any fuel leakage. Always use new hose clamps and ensure the security of the new filter by lightly pulling on each hose. Always perform maintenance outdoors or in a well-ventilated area. Do not smoke or allow any open flames in the vicinity of any maintenance activities.

CHANGING YOUR FUEL FILTER

1. Locate your fuel filter and mark the direction it is facing.
2. Clamp each side of the fuel filter to minimize any gas spills.
3. Remove the claps from each side of the fuel filter and remove the filter.
4. Place the new fuel filter in the same direction as the old one and place the clips back into place and remove clamps.

The air cleaner is the engines only defense against damaging foreign particles. It is very important that the air cleaner element is inspected prior to each use. Remove the element and tap its sides in order to remove debris. Do not blow the filter out using compressed air. Doing so will greatly reduce the air cleaner's effectiveness. Replace yearly: more often in dusty environments. Adhering to these practices will help prevent loss of power and premature engine failure.

CHANGING THE AIR CLEANER

1. Locate the air filter and unbuckle the air filter cover.
2. Remove the cover and take out the outer white element and the inner blue element.
3. Clean or replace elements.
4. Reattach the cover making sure the air intake is facing down.

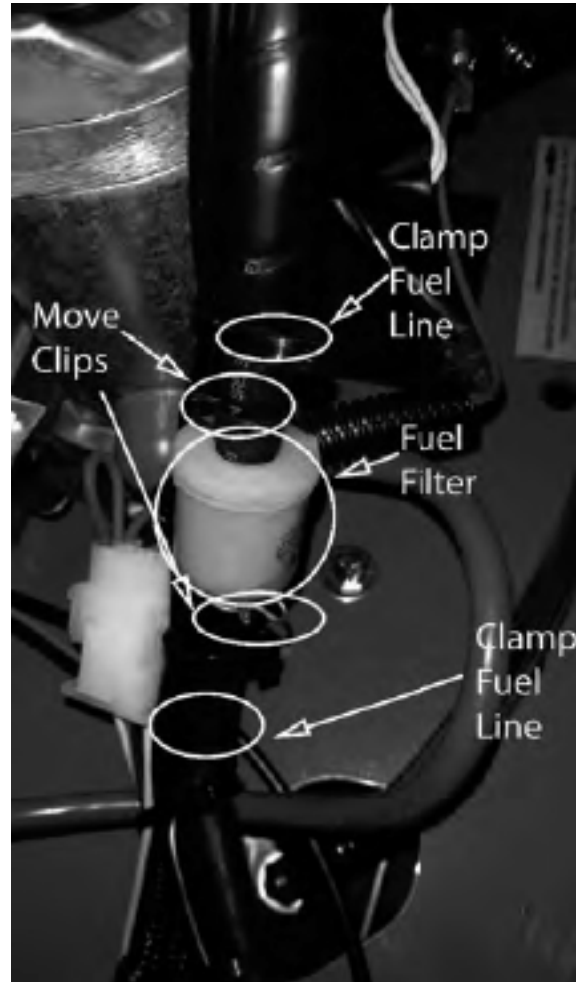



BAD BOY MOWERS

KAWASAKI FX850V (CONTINUED)

CHANGING THE SPARK PLUGS AND CHECKING THE SPARK PLUG GAP

1. Remove the wire on the spark plug and use a 13/16" socket to remove the spark plug.
2. Check the gap on the spark plug to verify that it is 0.03 in using a feeler gauge.
3. If the spark plug is worn, overheated, wet or carbon fouled replace the spark plug.
4. Install the plug into cylinder head and torque to 16 ft.-lbs. Be careful not to overtighten the spark plug.

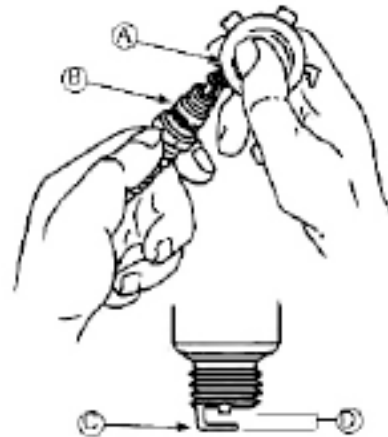

A	Wire Gauge	B	Spark Plug
C	Ground Electrode	D	Gap



YAMAHA 824cc

This machine has an oil drain hose installed on the engine to allow for easier oil changes. Bad Boy recommends that the oil and filter be changed after the initial 8 hrs. of use, and at intervals of 50 usage hours or yearly, whichever occurs first after that. The oil capacity is 2 quarts. Bad Boy 10W-30 synthetic blend engine oil is recommended for maximum protection.

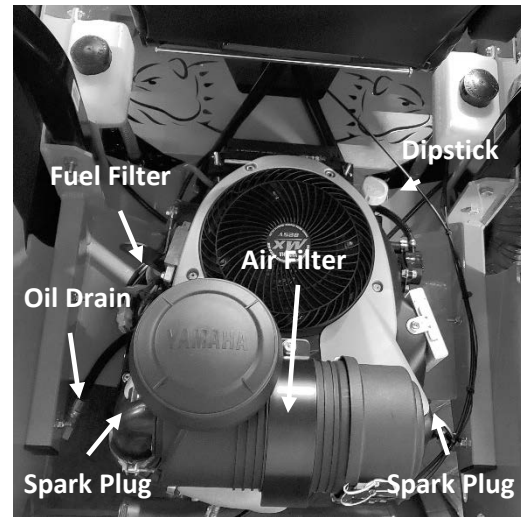

CHANGING YOUR ENGINE OIL AND OIL FILTER

1. Remove oil dipstick and open oil drain. Allow oil to completely drain. (Make sure to have an oil pan ready to capture old oil and properly dispose old oil.)
2. The oil filter is located on the right side of the engine. Clean area around oil filter. Place a container under the oil filter to capture any oil and remove filter. Wipe off mounting surface and reinstall drain plug. Torque to 10ft.-lb. Place new filter in shallow pan with open end up. Fill with new oil until oil reaches the bottom of the threads. Allow 2 minutes for oil to be absorbed by filter material.
3. Apply a thin film of clean oil to rubber gasket on new filter
4. Refer to instructions on oil filter for proper installation.
5. Fill crankcase with approximately 2 quarts of new oil. Level should top of indicator on dipstick.
6. Reinstall oil fill/dipstick and tighten securely.
7. Start engine; check for oil leaks. Stop Engine; correct oil leaks. Re-check oil level
8. Dispose of used oil and filter in accordance with local ordinances.

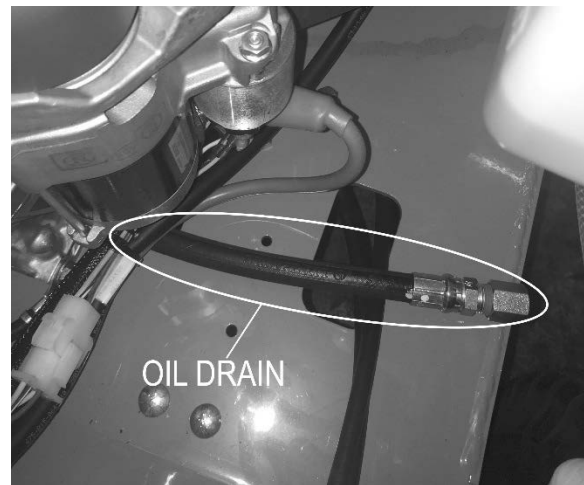
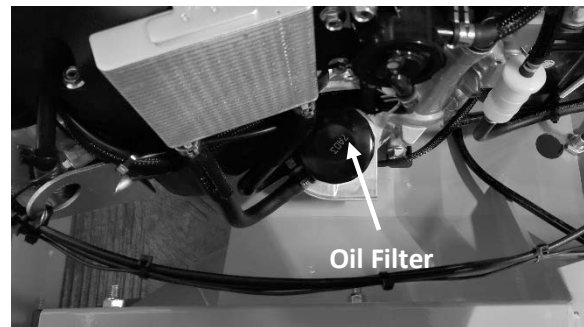

YAMAHA 824cc (CONTINUED)

The fuel filter is located in the fuel line about 12" from the carburetor on the side of the engine. Replace the filter yearly. Prior to the removal of the old filter, note the direction of fuel flow as indicated on the filter. Have towels readily available in order to quickly remove any fuel leakage. Always use new hose clamps and ensure the security of the new filter by lightly pulling on each hose. Always perform maintenance outdoors or in a well-ventilated area. Do not smoke or allow any open flames in the vicinity of any maintenance activities.

CHANGING YOUR FUEL FILTER

1. Locate your fuel filter and mark the direction it is facing.
2. Clamp each side of the fuel filter to minimize and gas spills.
3. Remove the clips from each side of the fuel filter and remove the fuel filter.
4. Place the new fuel filter in the same direction as the old and place clips back into place and remove clamps.

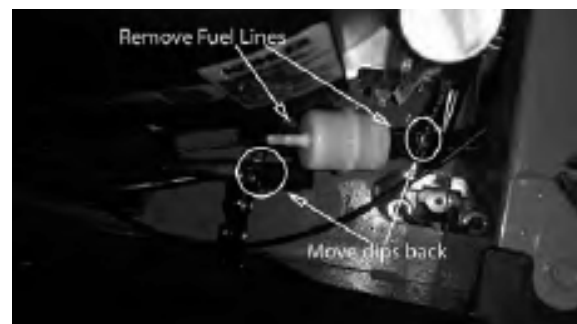
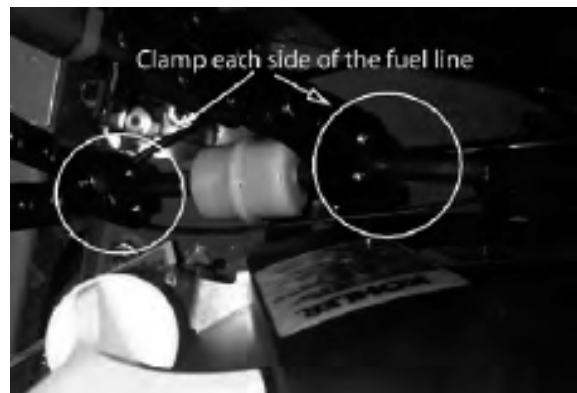



BAD BOY MOWERS

YAMAHA 824cc (CONTINUED)

The air cleaner is the engine's only defense against damaging foreign particles. It is very important that the air cleaner element is inspected prior to each use. Remove the element and tap its sides in order to remove debris. Do not blow the filter out using compressed air. Doing so will greatly reduce the air cleaner's effectiveness. Replace yearly; more often in dusty environments. Adhering to these practices will help prevent loss of power and premature engine failure.

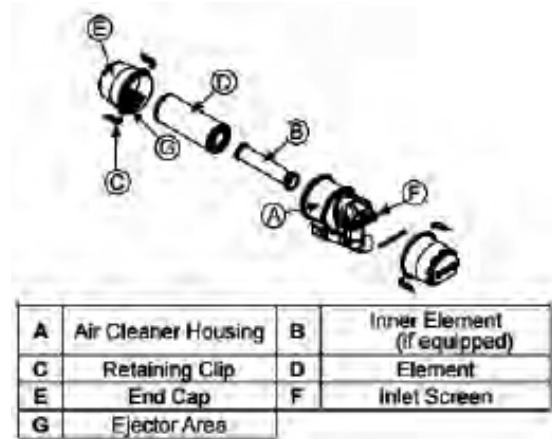

CHANGING THE AIR CLEANER

1. Unlock the air cleaner cover and remove to access the air cleaner.
2. Remove the outer and inner air filters.
3. Replace inner and outer filter then place the inner filter into the air intake followed by fitting the outer filter over the inner filter.
4. Install onto base and place cover back on and lock into place.

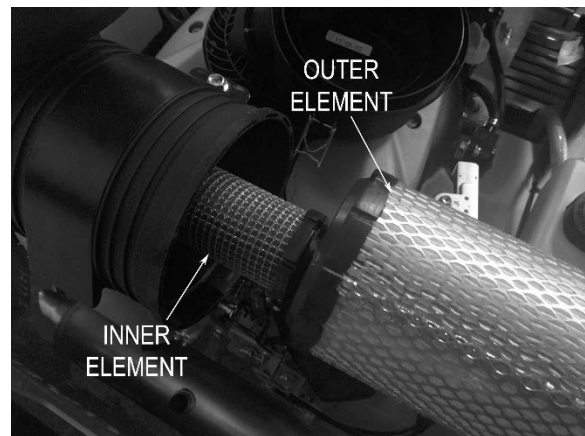

YAMAHA 824cc (CONTINUED)

CHANGING THE SPARK PLUGS AND CHECKING THE SPARK PLUG GAP

1. Remove the wire on the spark plug and use a 5/8" socket to remove the spark plug.
2. Check the gap on the spark plug to verify that it is 0.03 in using a feeler gauge.
3. If the spark plug is worn, overheated, wet or carbon fouled replace the spark plug.
4. Install the plug into cylinder head and torque to 20 ft.*lbs. Be careful not to overtighten the spark plug.

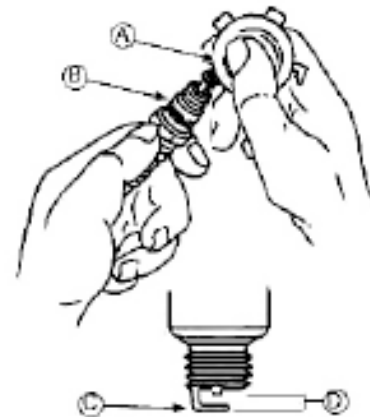

A	Wire Gauge	B	Spark Plug
C	Ground Electrode	D	Gap



KAWASAKI FX1000V

This machine has an oil drain hose installed on the engine to allow for easier oil changes. Bad Boy recommends that the oil and filter be changed after the initial 8 hrs. of use, and at intervals of 50 usage hours or yearly, whichever occurs first after that. The oil capacity is 2 quarts. Bad Boy 10W-30 synthetic blend engine oil is recommended for maximum protection.

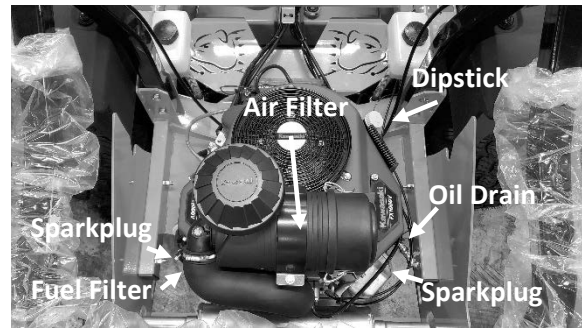

CHANGING YOUR ENGINE OIL AND OIL FILTER

1. Remove oil dipstick and open oil drain. Allow oil to completely drain. (Make sure to have an oil pan ready to capture old oil and properly dispose old oil.)
2. The oil filter is located on the right side of the engine. Clean area around oil filter. Place a container under the oil filter to capture any oil and remove filter. Wipe off mounting surface and reinstall drain plug. Torque to 10 ft.-lb.
3. Place new filter in shallow pan with open end up. Fill with new oil until oil reaches the bottom of the threads. Allow 2 minutes for oil to be absorbed by filter material.
4. Apply a thin film of clean oil to rubber gasket on new filter.
5. Refer to instructions on oil filter for proper installation.
6. Fill crankcase with approximately 2 quarts of new oil. Level should top of indicator on dipstick.
7. Reinstall oil fill/dipstick and tighten securely.
8. Start engine; check for oil leaks. Stop Engine; correct oil leaks. Recheck oil level.
9. Dispose of used oil and filter in accordance with local ordinances.

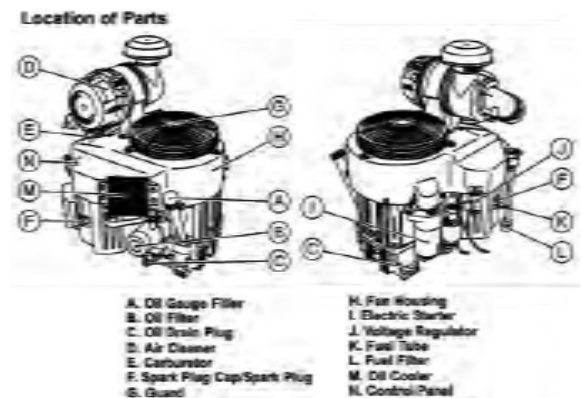
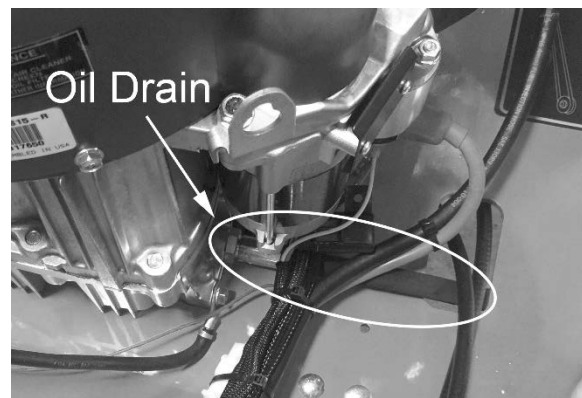

KAWASAKI FX1000V (CONTINUED)

The fuel filter is located in the fuel line on the left side of the engine by the starter motor. Replace the filter yearly. Prior to the removal of the old filter, note the direction of fuel flow as indicated on the filter. Have towels readily available in order to quickly remove any fuel leakage. Always use new hose clamps and ensure the security of the new filter by lightly pulling on each hose. Always perform maintenance outdoors or in a well-ventilated area. Do not smoke or allow any open flames in the vicinity of any maintenance activities.

CHANGING YOUR FUEL FILTER

1. Locate your fuel filter and mark the direction it is facing.
2. Clamp each side of the fuel filter to minimize any gas spills.
3. Remove the clips from each side of the fuel filter and remove the filter.
4. Place the new fuel filter in the same direction as the old one and place the clips back into place and remove clamps.

The air cleaner is the engine's only defense against damaging foreign particles. It is very important that the air cleaner element is inspected prior to each use. Remove the element and tap its sides in order to remove debris. Do not blow the filter out using compressed air. Doing so will greatly reduce the air cleaner's effectiveness. Replace yearly; more often in dusty environments. Adhering to these practices will help prevent loss of power and premature engine failure.

CHANGING THE AIR CLEANER

1. Locate the air filter and unbuckle the air filter cover.
2. Remove the cover and take out the outer white element and the inner blue element.
3. Clean or replace elements.
4. Reattach the cover making sure the air intake is facing down.

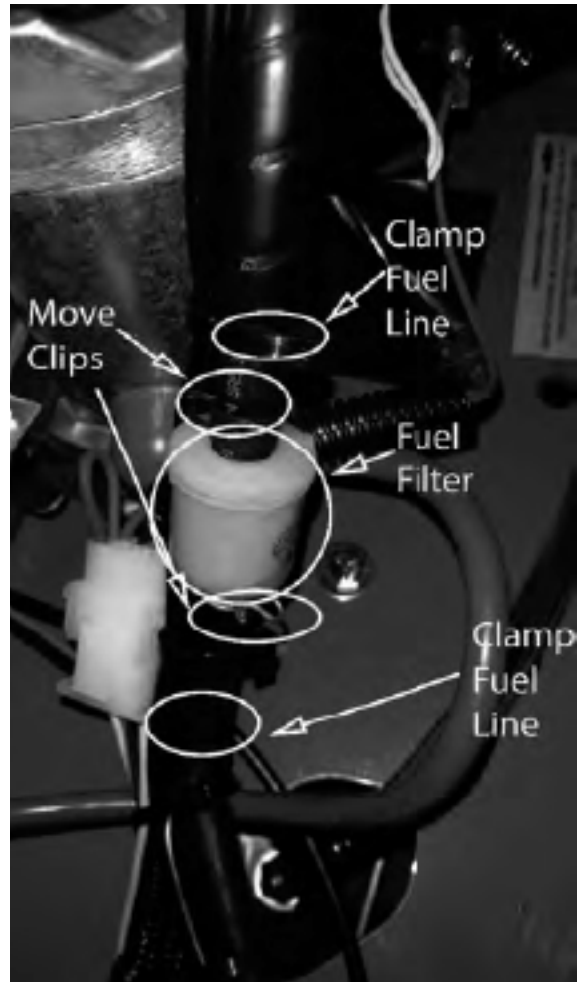



BAD BOY MOWERS

KAWASAKI FX1000V (CONTINUED)

CHANGING THE SPARK PLUGS AND CHECKING THE SPARK PLUG GAP

1. Remove the wire on the spark plug and use a 13/16" socket to remove the spark plug.
2. Check the gap on the spark plug to verify that it is 0.03 in using a feeler gauge.
3. If the spark plug is worn, overheated, wet or carbon fouled replace the spark plug.
4. Install the plug into cylinder head and torque to 16 ft.-lbs. Be careful not to overtighten the spark plug.

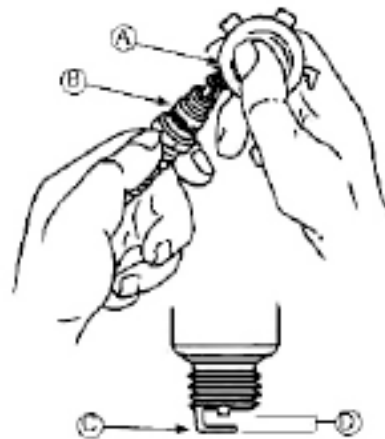

A	Wire Gauge	B	Spark Plug
C	Ground Electrode	D	Gap

VANGUARD 993CC

This machine has an oil drain hose installed on the engine to allow for easier oil changes. Bad Boy recommends that the oil and filter be changed after the initial 8 hrs. of use, and at intervals of 50 usage hours or yearly, whichever occurs first after that. The oil capacity is 2 quarts. Bad Boy 10W-30 synthetic blend engine oil is recommended for maximum protection.

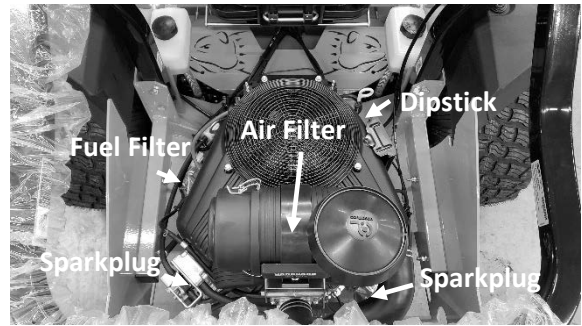

CHANGING YOUR ENGINE OIL AND OIL FILTER

1. Remove oil fill cap and open oil drain. Allow oil to completely drain. (Make sure to have an oil pan ready to capture old oil and properly dispose old oil.)
2. The oil filter is located on the right side of the engine. Clean area around oil filter. Place a container under the oil filter to capture any oil and remove filter. Wipe off mounting surface and reinstall drain plug. Torque to 10 ft.*lb.
3. Place new filter in shallow pan with open end up. Fill with new oil until oil reaches the bottom of the threads. Allow 2 minutes for oil to be absorbed by filter material.
4. Apply a thin film of clean oil to rubber gasket on new filter
5. Refer to instructions on oil filter for proper installation.
6. Fill crankcase with approximately 2 quarts of new oil. Level should top of indicator on dipstick.
7. Reinstall oil fill/dipstick and tighten securely.
8. Start engine; check for oil leaks. Stop Engine; correct oil leaks. Recheck oil level
9. Dispose of used oil and filter in accordance with local ordinances.





BAD BOY MOWERS

VANGUARD 993CC (CONTINUED)

The fuel filter is located in the fuel line about 12" from the carburetor on the side of the engine. Replace the filter yearly. Prior to the removal of the old filter, note the direction of fuel flow as indicated on the filter. Have towels readily available in order to quickly remove any fuel leakage. Always use new hose clamps and ensure the security of the new filter by lightly pulling on each hose. Always perform maintenance outdoors or in a well-ventilated area. Do not smoke or allow any open flames in the vicinity of any maintenance activities.

CHANGING YOUR FUEL FILTER

1. Locate your fuel filter and mark the direction it is facing.
2. Clamp each side of the fuel filter to minimize and gas spills.
3. Remove the clips from each side of the fuel filter and remove the fuel filter.
4. Place the new fuel filter in the same direction as the old and place clips back into place and remove clamps.

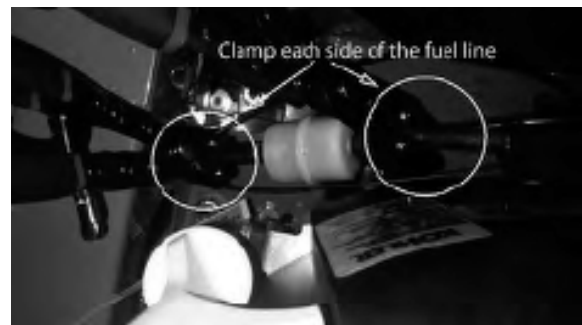
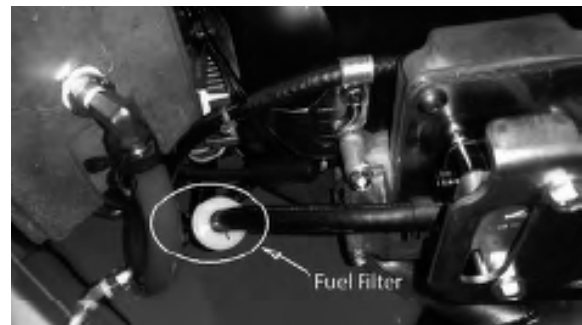



VANGUARD 993CC *(CONTINUED)*

The air cleaner is the engine's only defense against damaging foreign particles. It is very important that the air cleaner element is inspected prior to each use. Remove the element and tap its sides in order to remove debris. Do not blow the filter out using compressed air. Doing so will greatly reduce the air cleaner's effectiveness. Replace yearly; more often in dusty environments. Adhering to these practices will help prevent loss of power and premature engine failure.

993 Vanguard Air Cleaner Component List

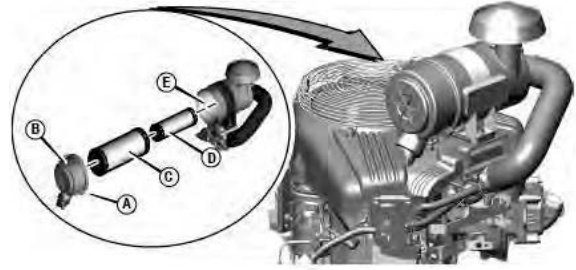

- A. Latches
- B. Cap
- C. Outer Air Filter
- D. Inner Air Filter
- E. Air Intake

CHANGING YOUR AIR CLEANER

1. Unlock the air cleaner cover and remove to access the air cleaner.
2. Remove the outer and inner air filters.
3. Replace inner and outer filter then place the inner filter into the air intake followed by fitting the outer filter over the inner filter.
4. Place cap back on and close the latches.

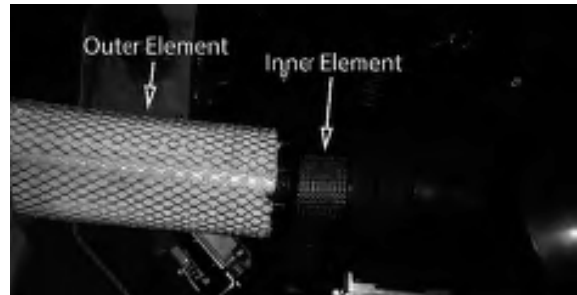



BAD BOY MOWERS

VANGUARD 993CC (CONTINUED)

CHANGING THE SPARK PLUGS AND CHECKING THE SPARK PLUG GAP

1. Remove the wire on the spark plug and use a 5/8" socket to remove the spark plug.
2. Check the gap on the spark plug to verify that it is 0.03 in using a feeler gauge.
3. If the spark plug is worn, overheated, wet, or carbon fouled replace the spark plug.
4. Install the plug into cylinder head and torque to 20ft.-lbs. Be careful not to overtighten the spark plug.

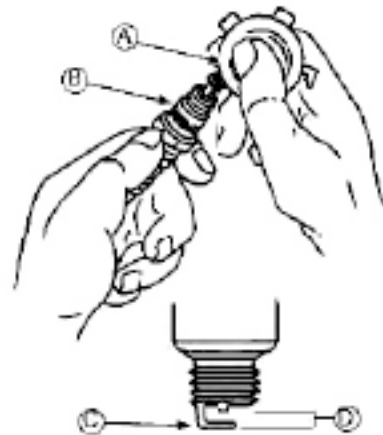

A	Wire Gauge	B	Spark Plug
C	Ground Electrode	D	Gap



BAD BOY MOWERS

SECTION 4: ELECTRICAL SYSTEM

This mower is equipped with one protective fuse: a 30-amp main fuse (pictured to the right).

A blown fuse usually indicates a problem within the electrical system or an electrical component. Ensure the battery terminals are tightly fastened. Never replace a fuse with one of a higher amperage rating or 'bypass' a fuse in any way. Doing so creates a significant fire hazard and can cause severe damage to the mowers electrical components. If a fuse is repeatedly blowing, contact your Bad Boy dealer.

On most models, the red wire coming out of the engine is the charging wire from the alternator. Check for 13.6 - 14.2 volts dc at this wire with engine at full throttle.

If you are having issues starting your mower ensure the signal wire is connected to your starter solenoid.

Check the condition and connection of the relays located under the control panel. Ensure that they are clean and connected. Make sure that wire terminal ends have not been pushed out of the relay block.

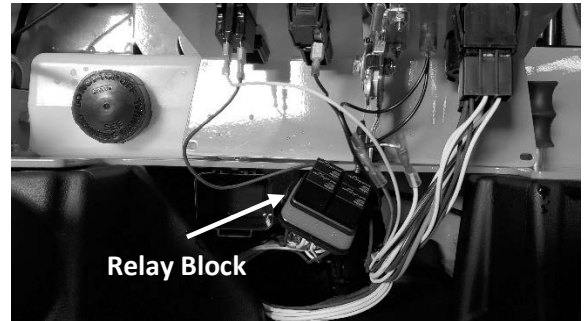
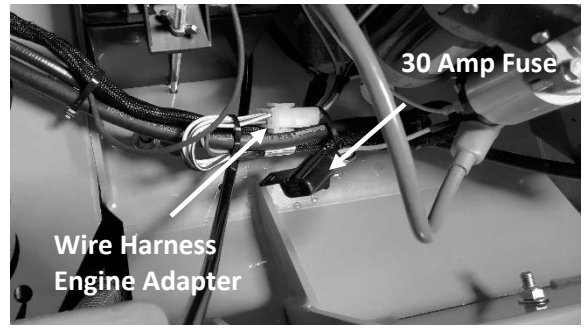



BAD BOY MOWERS

ELECTRICAL SYSTEM (CONTINUED)

WIRING DIAGRAM

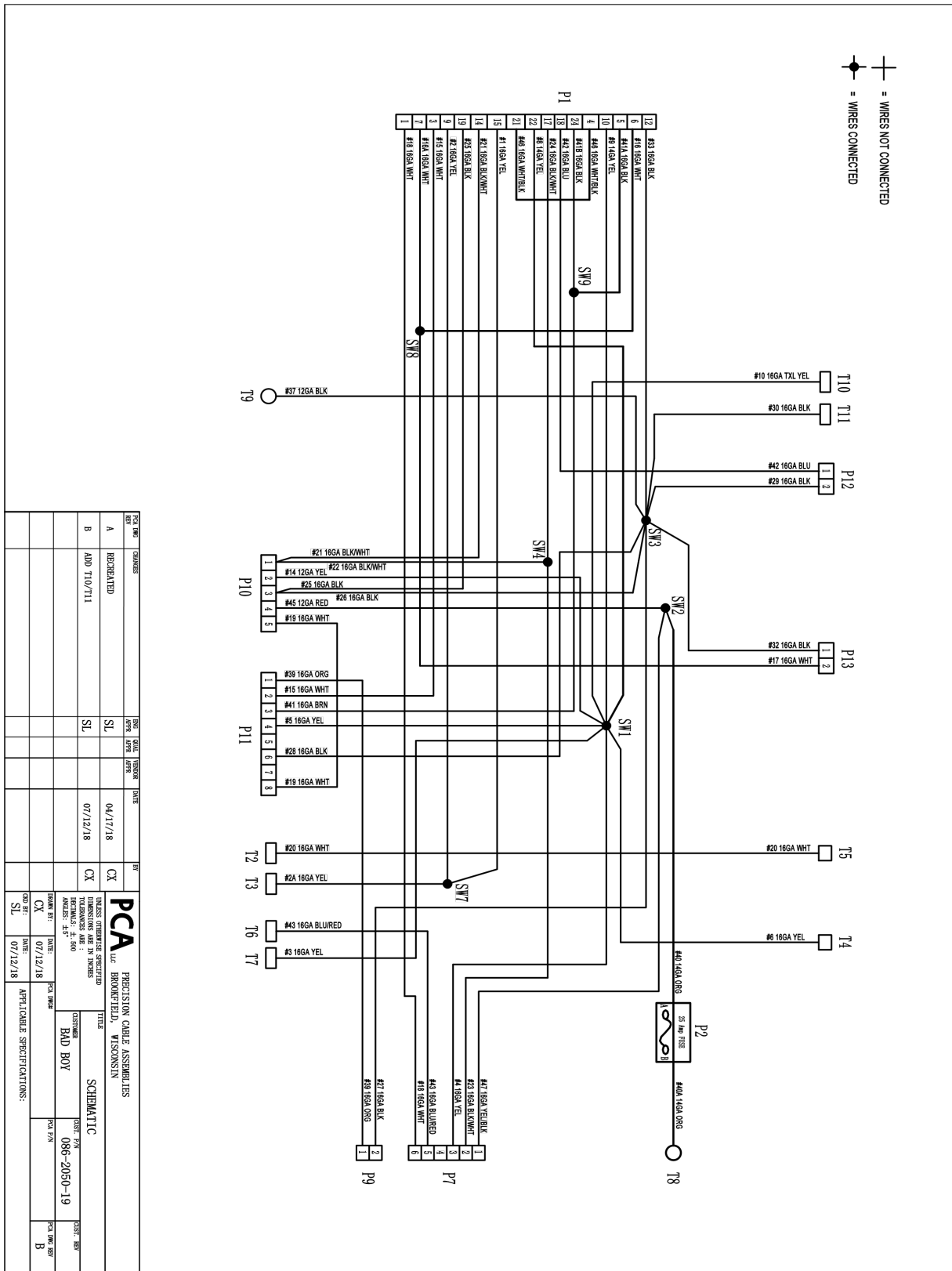

REV	CHANGES	DATE	BY	DATE	BY
A	RECREATED	04/17/18	SL		
B	ADD T10/T11	07/12/18	SL		

PCA PRECISION CABLE ASSEMBLIES LLC - BROOKFIELD, WISCONSIN 2500 WISCONSIN ST. #100 BROOKFIELD, WI 53005 TEL: 262.781.1111 FAX: 262.781.1112 WWW.PCAWI.COM	TITLE SCHMATIC CUSTOMER BAD BOY PART NO. 086-2050-19 REV. B
---	--

SECTION 5: FRAME

The front fork nuts require a torque of 40ft-lbs. While applying this torque, turn the fork itself to ensure no damage is done to the bearing. This operation is only necessary if a repair requires it.

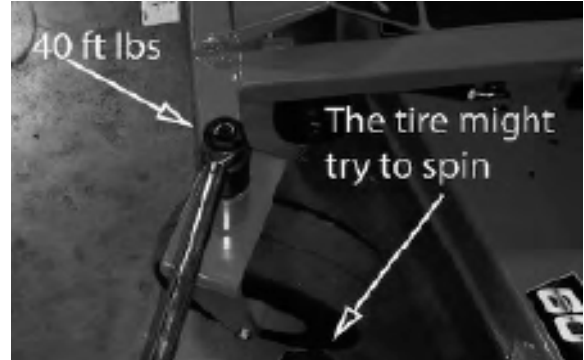

Torque rear wheel lugs to 65-75 ft. lbs. Re-torque at every oil change and check at every mowing.



There are two grease zerks located on each of the two turnbuckles (4 Total). Grease at every oil change.

The pump belt tensioner is located under the engine and has a grease fitting at its pivot point. Grease at every engine oil change.



The deck belt tensioner is located at the rear of the deck and has a grease fitting on its pivot point. Grease at every engine oil change.

The control arm blocks have grease fittings located on each side of the steering arm bar. Grease at every engine oil change.





SECTION 6: CUTTING DECK

DECK BELT REMOVAL

1. Remove ignition key.
2. Raise the deck to its highest position.
3. Remove the right pulley cover.
4. While lifting up on the belt (as shown in the photograph), rotate the pulley until the belt is free of the pulley. Exercise caution while performing this step as fingers can easily become caught between the belt and pulley.



DECK BELT INSTALLATION

1. Remove ignition key.
2. Raise the deck to its highest position.
3. Take off both pulley covers and route the belt by following the belt route decal. (The easiest way to finish running the belt is routing the belt through the deck pulleys and carefully slipping the belt onto the clutch in the rear of the engine.)
4. Verify that the belt is routed properly as improper routing can damage the spindles as well as the engine.

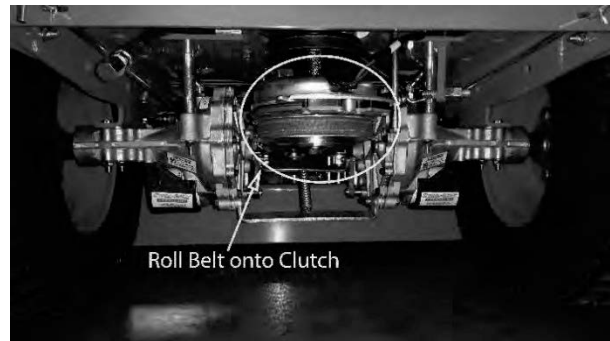



LEVELING THE DECK

1. Start on a flat, level surface and set the air pressure in the front tires to 12 psi. and 8 psi. in the rear. Measure the deck at all four corners. The deck should be level from left to right but 1/4" lower in the front than in the rear. Adjustments can be made by adjusting the deck hangers in their slots.
2. Using a pair of approximately 3 ft. long 2x4's, stand the boards on edge and slide them under the deck from front to back as shown.
3. Lower the deck down onto the 2x4's using either the deck lift pedal or the electric actuator, whichever your mower is equipped with. The deck should now be approximately 3.5" off the ground. To achieve the proper 1/4" pitch down in the front it may be necessary to use some 1/4" spacers under the rear of the deck as shown.
4. Using a pair of 3/4" wrenches, loosen all deck hanger bolts on the top of the deck. These are the lower bolts in the slots of the deck as shown. Do not loosen the upper bolts that attach the deck hangers to the actuator lift bars. Your mower is also equipped with a deck lift assist. This will cause the actuator bars to lift on their own once all the deck hangers have been loosened. If this happens, it may be necessary to remove the deck lift assist shock from the mower, otherwise it may be difficult to manually overpower the force of the lift shock.
5. The deck is now loose from the frame and movement of the lift pedal or electric actuator should only move the hanger bolts up and down in the deck slots. At this point a different deck height may be chosen on the cutting height dial. Choosing a lower number will raise the decks cutting height. Choosing a higher number will decrease the decks overall cutting height. Remember, you should be approximately in the 4" range on your selection.
6. After setting the deck dial to the desired position and securing the lift pedal rearwards until it stops, tighten all deck hanger bolts in their slots starting from the rear of the deck then moving to the front. Lift the deck to the highest position. measure all four corners of the deck again to ensure that no further adjustments are necessary.
7. Recheck belt tension before mowing.

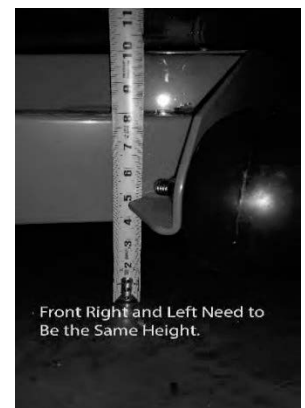
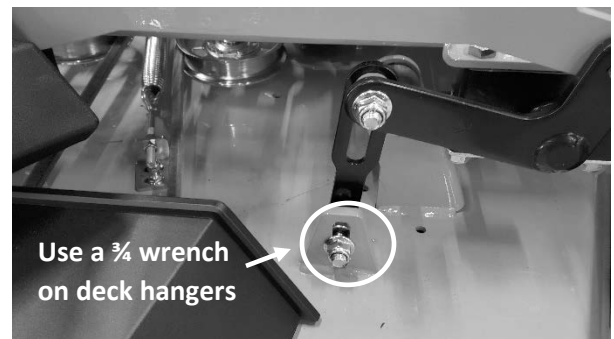



ADJUST DECK BELT TENSION

The deck spring tension is critical. If the tension is too high, premature failure of the deck belt and blade spindles can occur. If the tension is too low, the belt can "jump off" or slip on the pulleys. This results in reduced cut quality and early belt failure.

Spring tension adjustments can be made by sliding the bolt shown above forward or backward in the slot of the deck. Belt tension should be 60-65 lbs. with the deck at its lowest setting.

Use a belt tension gauge to ensure the proper tension. Your dealer or service center will have a belt tension

gauge or you can buy one (Part Number 041-9999-00).



BLADE SHARPENING

The blade on the top (see photo) was utilized long after replacement was required. In addition to a decline in cut quality, failure to replace a worn or damaged blade creates a major safety hazard. Bad Boy recommends that blade sharpening be performed by a professional.





BLADE REMOVAL

To change blades, it may be easier to use a piece of wood to keep the blade from turning so that the bolt can be loosened. Use a 15/16" socket and impact drill, or a wrench and an extension to gain more leverage.

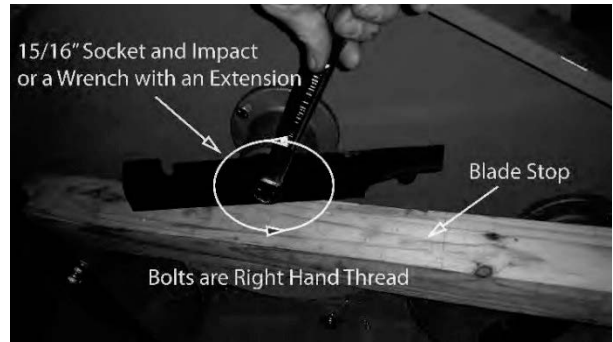

Re-torque the blade bolts to 90-110 lbs.

The blade spindles contain a sealed ball bearing inside the top and bottom of the spindle. The bearings are replaceable for a more cost-effective repair.





BAD BOY MOWERS

PARTS SECTION: 54" DECK ASSEMBLY

Parts List				Parts List			
ITEM	QTY	PART NUMBER	DESCRIPTION	ITEM	QTY	PART NUMBER	DESCRIPTION
1	2	013-5201-00	3/8" Flange Nut	23	3	019-6020-00	1/2" Belleville Washer
2	14	013-6014-00	3/8" Hex Nut	24	4	019-6050-00	.360 ID Plastic Washer-Black
3	1	013-7021-00	5/8 Std NC Nylock Nut	25	6	022-1001-00	2019 Deck Wheel
4	4	013-8049-00	5/16" Nylon Flange Nut	26	2	025-5338-00	.502 ID X .750 OD X 1.500 Long Spacer
5	12	013-8050-00	1/2-13 Nylon Flange Nut	27	1	025-5339-00	1 3/4" Pulley Spacer
6	1	014-5050-00	2019 54" Left Outlaw Gen2 Pulley Cover	28	1	025-7020-00	5/8" x 1" Collar W/One Set Screw
7	1	014-5051-00	2019 54" Right Outlaw Gen2 Pulley Cover	29	1	029-7036-00	REVISED TRIM BUMPER_20180226
8	1	018-0046-00	1/2-13 x 8 Hex Bolt Grade 5	30	3	030-0050-00	5/16 Set Screw
9	2	018-2007-00	5/16-18 x 1 GR 5 Hex Bolt Zinc	31	3	033-6006-00	5.25" Deck Spindle Pulley
10	3	018-2018-00	1/2 x 3 1/2 Flange Bolt Grade 8	32	3	033-7201-25	5-3/4 Idler Pulley
11	1	018-4707-00	4" 3/8-16 Eye Bolt	33	1	034-2030-00	2019 Outlaw Gen2 Deck Spring
12	4	018-5019-00	1/2" x 4" Bolt (Grade 8)	34	3	037-4000-00	OUTLAW SPINDLE ASSEMBLY
13	12	018-5040-00	3/8" x 1 1/4" Hex Bolt	35	3	038-0001-00	54" Deck Fusion Blade For Outlaw
14	2	018-5250-00	3/8" x 3/4" Hex Bolt	36	1	039-0144-00	2019 Deck Eye Bolt Tab
15	3	018-6019-00	1/2"-20 x 1 1/2 - Grade 5 Fine Thread Bolt	37	4	039-2125-17	Deck Hangar Assembly
16	3	018-6020-00	5/8" x 1 1/2" Grade 8 Hex Bolt (Fine)	38	1	039-6946-18	2019 Rebel Rogue Deck Idler
17	1	018-6059-00	5/8" x 2 1/2" Grade 5 Hex Bolt (Coarse)	39	1	041-1650-00	B165 Belt-60 54" deck Outlaw
18	4	018-7050-00	1/2" x 4 1/2" Bolt	40	3	042-6030-00	1/4" x 1" Key
19	2	018-8066-00	5/16" x 7/8" Carriage Bolt	41	4	045-6043-00	5/16" Knob
20	3	019-5007-00	1/2" Lock Washer	42	2	048-7000-00	Turnbuckle
21	12	019-5037-00	3/8" Lock Washer	43	1	060-5551-19	2019 Sloped 54" Deck
22	3	019-5038-00	5/8" Flat Washer	44	1	210-7000-98	2019 Outlaw Gen2 Chute Assembly

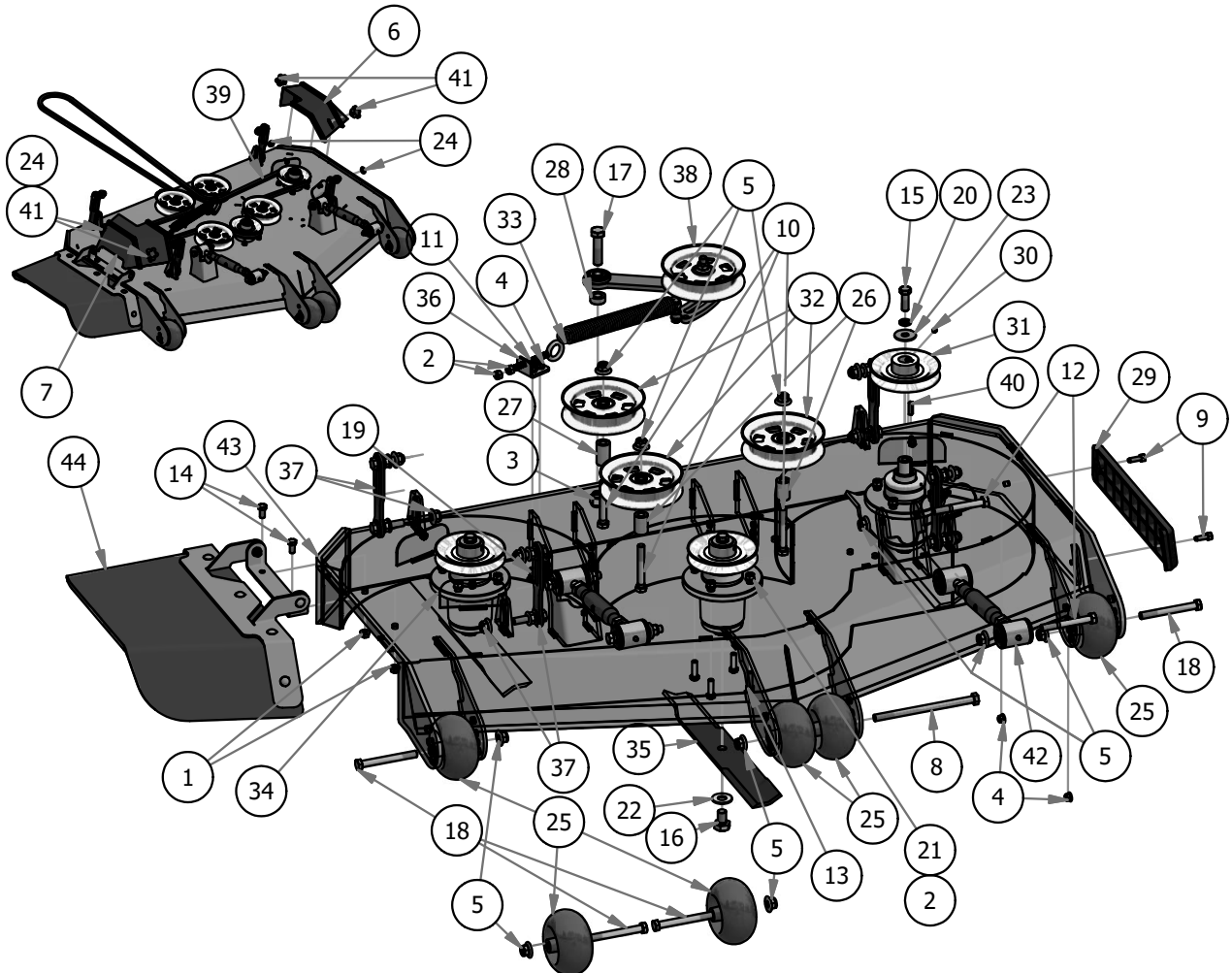



BAD BOY MOWERS

PARTS SECTION: 61" DECK ASSEMBLY

Parts List				Parts List			
ITEM	QTY	PART NUMBER	DESCRIPTION	ITEM	QTY	PART NUMBER	DESCRIPTION
1	2	013-5201-00	3/8" Flange Nut	23	3	019-6020-00	1/2" Belleville Washer
2	14	013-6014-00	3/8" Hex Nut	24	4	019-6050-00	.360 ID Plastic Washer-Black
3	1	013-7021-00	5/8 Std NC Nylock Nut	25	6	022-1001-00	2019 Deck Wheel
4	4	013-8049-00	5/16" Nylon Flange Nut	26	2	025-5338-00	.502 ID X .750 OD X 1.500 Long Spacer
5	12	013-8050-00	1/2-13 Nylon Flange Nut	27	1	025-5339-00	1 3/4" Pulley Spacer
6	1	014-5052-00	2019 61" Outlaw Gen2 Pulley Cover Left	28	1	025-7020-00	5/8" x 1" Collar W/One Set Screw
7	1	014-5053-00	2019 61" Outlaw Gen2 Pulley Cover Right	29	1	029-7036-00	REVISED TRIM BUMPER_20180226
8	1	018-0046-00	1/2-13 x 8 Hex Bolt Grade 5	30	3	030-0050-00	5/16 Set Screw
9	2	018-2007-00	5/16-18 x 1 GR 5 Hex Bolt Zinc	31	3	033-6004-00	6 1/4" Drive Pulley
10	3	018-2018-00	1/2 x 3 1/2 Flange Bolt Grade 8	32	3	033-7201-25	5-3/4 Idler Pulley
11	1	018-4707-00	4" 3/8-16 Eye Bolt	33	1	034-2030-00	2019 Outlaw Gen2 Deck Spring
12	4	018-5019-00	1/2" x 4" Bolt (Grade 8)	34	3	037-4000-00	OUTLAW SPINDLE ASSEMBLY
13	12	018-5040-00	3/8" x 1 1/4" Hex Bolt	35	3	038-6080-00	61 inch Fusion Blade
14	2	018-5250-00	3/8" x 3/4" Hex Bolt	36	1	039-0144-00	2019 Deck Eye Bolt Tab
15	3	018-6019-00	1/2"-20 x 1 1/2 - Grade 5 Fine Thread Bolt	37	4	039-2125-17	Deck Hangar Assembly
16	3	018-6020-00	5/8" x 1 1/2" Grade 8 Hex Bolt (Fine)	38	1	039-6946-18	2019 Rebel Rogue Deck Idler
17	1	018-6059-00	5/8" x 2 1/2" Grade 5 Hex Bolt (Coarse)	39	1	041-0178-00	B178 Belt
18	4	018-7050-00	1/2" x 4 1/2" Bolt	40	3	042-6030-00	1/4" x 1" Key
19	2	018-8066-00	5/16" x 7/8" Carriage Bolt	41	4	045-6043-00	5/16" Knob
20	3	019-5007-00	1/2" Lock Washer	42	2	048-7000-00	Turnbuckle
21	12	019-5037-00	3/8" Lock Washer	43	1	060-6151-19	2019 Sloped 61" Deck
22	3	019-5038-00	5/8" Flat Washer	44	1	210-7000-98	2019 Outlaw Gen2 Chute Assembly

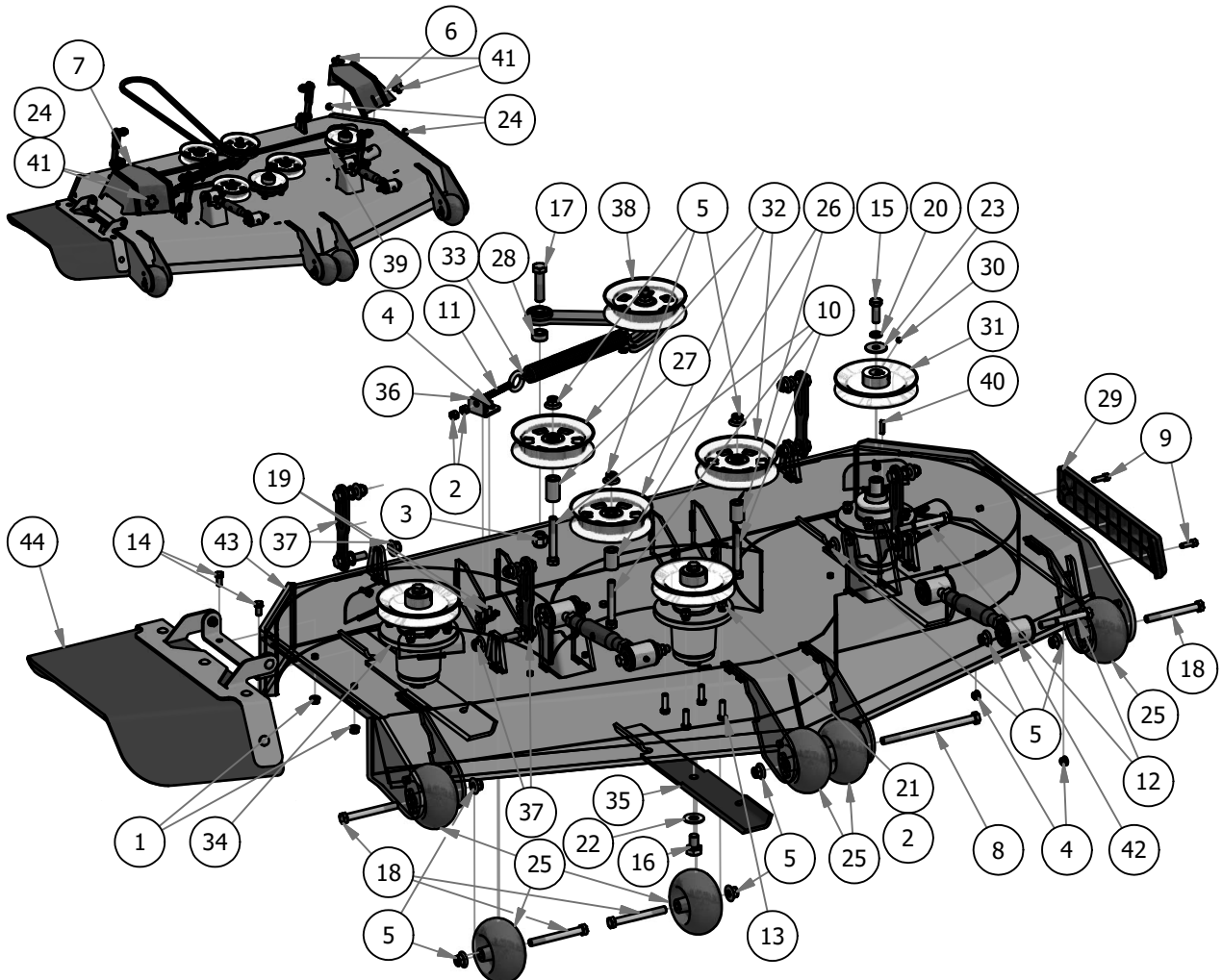



BAD BOY MOWERS

PARTS SECTION: 72" DECK ASSEMBLY

Parts List				Parts List			
ITEM	QTY	PART NUMBER	DESCRIPTION	ITEM	QTY	PART NUMBER	DESCRIPTION
1	2	013-5201-00	3/8" Flange Nut	23	3	019-6020-00	1/2" Belleville Washer
2	14	013-6014-00	3/8" Hex Nut	24	4	019-6050-00	.360 ID Plastic Washer-Black
3	1	013-7021-00	5/8 Std NC Nylock Nut	25	6	022-1001-00	2019 Deck Wheel
4	4	013-8049-00	5/16" Nylon Flange Nut	26	2	025-5338-00	.502 ID X .750 OD X 1.500 Long Spacer
5	12	013-8050-00	1/2-13 Nylon Flange Nut	27	1	025-5339-00	1 3/4" Pulley Spacer
6	1	014-5054-00	2019 72" Left Outlaw Gen2 Pulley Cover	28	1	025-7020-00	5/8" x 1" Collar W/One Set Screw
7	1	014-5055-00	2019 72" Right Outlaw Gen2 Pulley Cover	29	1	029-7036-00	REVISED TRIM BUMPER_20180226
8	1	018-0046-00	1/2-13 x 8 Hex Bolt Grade 5	30	3	030-0050-00	5/16 Set Screw
9	2	018-2007-00	5/16-18 x 1 GR 5 Hex Bolt Zinc	31	3	033-7201-25	5-3/4 Idler Pulley
10	3	018-2018-00	1/2 x 3 1/2 Flange Bolt Grade 8	32	3	033-7203-00	7" Deck Pulley
11	1	018-4707-00	4" 3/8-16 Eye Bolt	33	1	034-2030-00	2019 Outlaw Gen2 Deck Spring
12	4	018-5019-00	1/2" x 4" Bolt (Grade 8)	34	3	037-4000-00	OUTLAW SPINDLE ASSEMBLY
13	2	018-5250-00	3/8" x 3/4" Hex Bolt	35	3	038-7230-00	72" High Lift Fusion Blade
14	12	018-6012-00	3/8 x 1.5" Bolt	36	1	039-0144-00	2019 Deck Eye Bolt Tab
15	3	018-6019-00	1/2"-20 x 1 1/2 - Grade 5 Fine Thread Bolt	37	4	039-2125-17	Deck Hangar Assembly
16	3	018-6020-00	5/8" x 1 1/2" Grade 8 Hex Bolt (Fine)	38	1	039-6946-18	2019 Rebel Rogue Deck Idler
17	1	018-6059-00	5/8" x 2 1/2" Grade 5 Hex Bolt (Coarse)	39	1	041-0202-00	B202 Belt for 72" Outlaw
18	4	018-7050-00	1/2" x 4 1/2" Bolt	40	3	042-6030-00	1/4" x 1" Key
19	2	018-8066-00	5/16" x 7/8" Carriage Bolt	41	4	045-6043-00	5/16" Knob
20	3	019-5007-00	1/2" Lock Washer	42	2	048-7000-00	Turnbuckle
21	12	019-5037-00	3/8" Lock Washer	43	1	060-7251-19	2019 Sloped 72" Deck
22	3	019-5038-00	5/8" Flat Washer	44	1	210-7000-98	2019 Outlaw Gen2 Chute Assembly

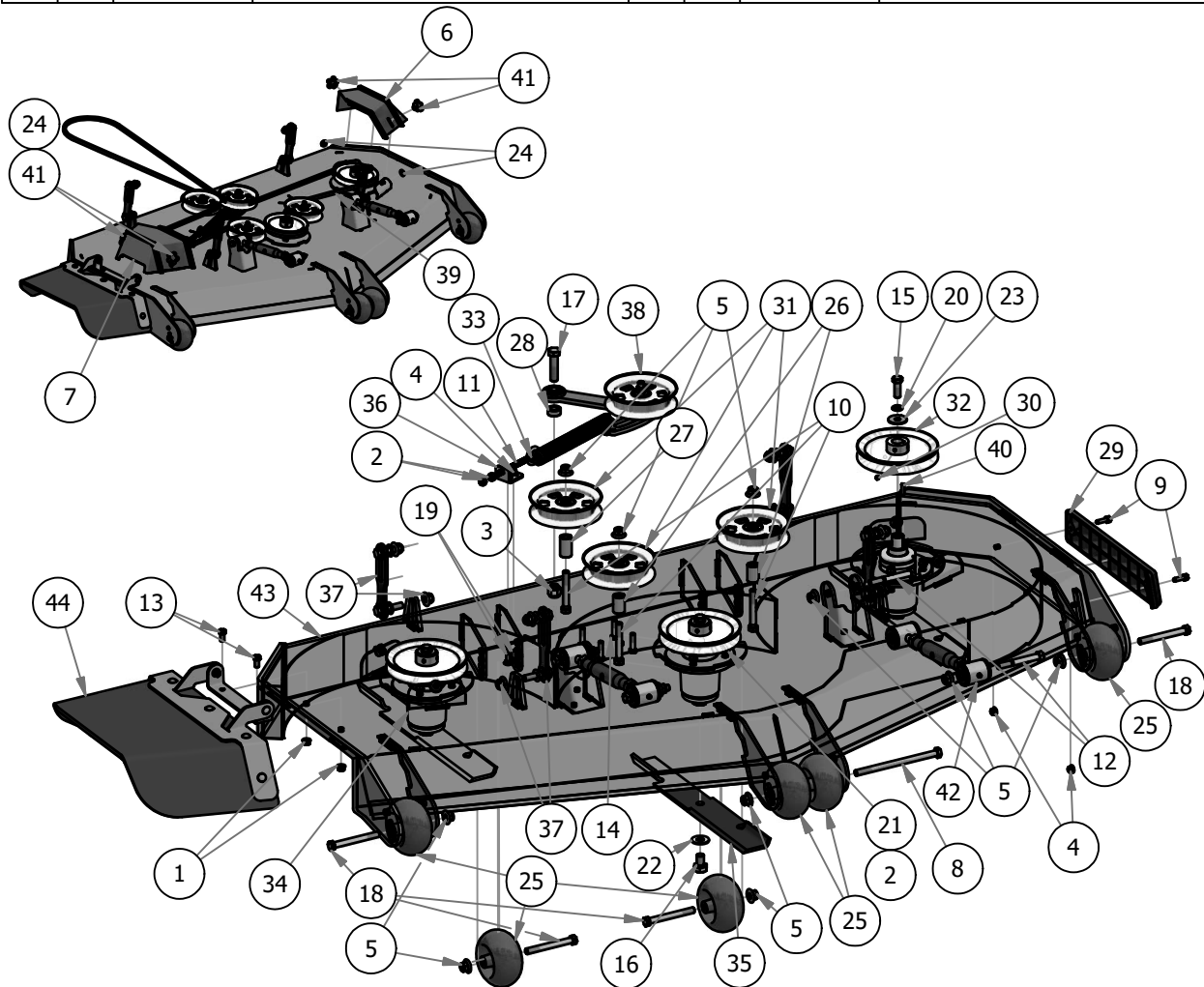



BAD BOY MOWERS

PARTS SECTION: DECK SUB-ASSEMBLIES

037-4000-00 Parts List				048-7000-00 Parts List			
ITEM	QTY	PART NUMBER	DESCRIPTION	ITEM	QTY	PART NUMBER	DESCRIPTION
1	1	037-4000-01	4000 Series Spindle Housing	19	1	013-0007-00	Hex Nut, 11/16-12
2	1	037-4002-00	4000 Series Spindle Spacer	20	1	013-0008-00	Hex Nut, 11/16-12 Left Handed
3	1	037-9050-00	Locking Collar w/ 1/4"-20 Set Screw	21	2	024-6034-00	1/4" Press in Grease Fitting
4	2	037-8002-00	Spindle Dust Cap	22	4	032-2000-00	Bushing
5	1	037-6026-00	Spindle Shaft	23	2	032-2001-00	Sleeve
6	4	037-6023-00	Bearing - 6206	24	1	048-7020-00	2015 Outlaw Turnbuckle Body
039-2125-17 Parts List				25	1	048-7021-00	Turnbuckle End Right-Handed Thread
7	2	013-5300-00	1/2" Flange Nut	26	1	048-7022-00	Turnbuckle End Left-Handed Thread
8	2	013-8050-00	1/2-13 Nylon Flange Nut	210-7000-98 Parts List			
9	2	018-6037-00	1/2-13X 2-1/4 GR Hex Bolts	ITEM	QTY	PART NUMBER	DESCRIPTION
10	4	019-8054-00	.505 Nylon Spacer	27	7	013-8049-00	5/16" Nylon Flange Nut
11	1	039-2125-00	Deck_Hanging_Tab	28	5	018-4703-00	5/16" x 1 1/4" Carriage Bolt
039-3946-18 Parts List				29	2	018-8066-00	5/16" x 7/8" Carriage Bolt
ITEM	QTY	PART NUMBER	DESCRIPTION	30	2	019-6042-00	.360 ID Plastic Washer
12	2	013-5201-00	3/8" Flange Nut	31	1	039-4893-00	2019 Upper Chute Bracket
13	1	013-8050-00	1/2-13 Nylon Flange Nut	32	1	039-4894-00	2019 Lower Chute Bracket
14	1	018-6012-00	3/8 x 1.5" Bolt	33	1	206-6018-00	2019 Chute Hanger
15	1	018-6036-00	1/2" x 2 3/4" Hex Bolt	34	1	210-6025-00	2019 Belted Chute with Logo
16	1	025-5203-00	Spacer 3/4 OD x 1/2 ID x 3/4 Length				
17	1	033-8050-00	5" Idler Pulley				
18	1	039-6946-00	2019 Deck Tensioner				

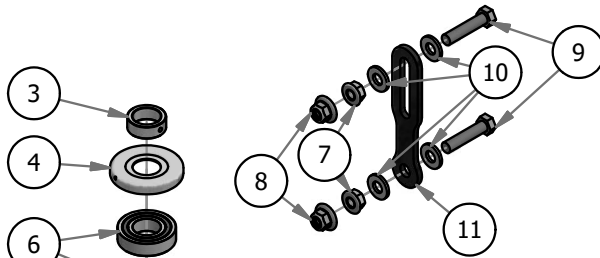

**039-2125-17
Deck Hangar Assembly**

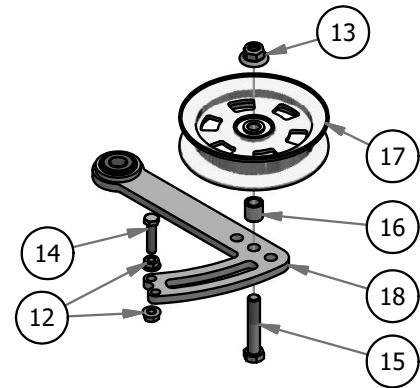

**039-6946-18
2019 Rebel Rogue Deck Idler**

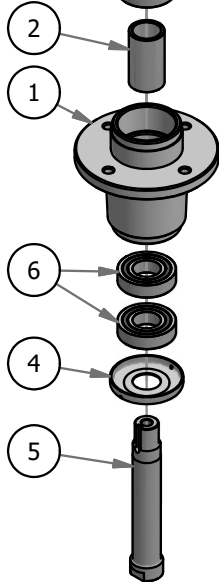

**037-4000-00
OUTLAW SPINDLE ASSEMBLY**

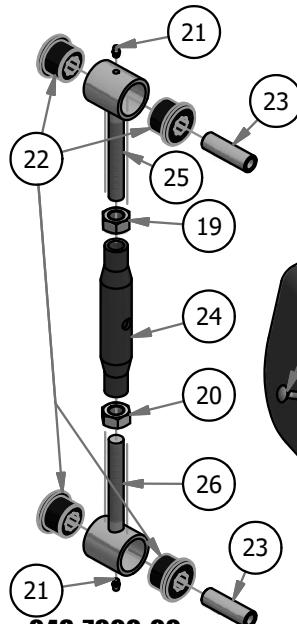

**048-7000-00
Turnbuckle**

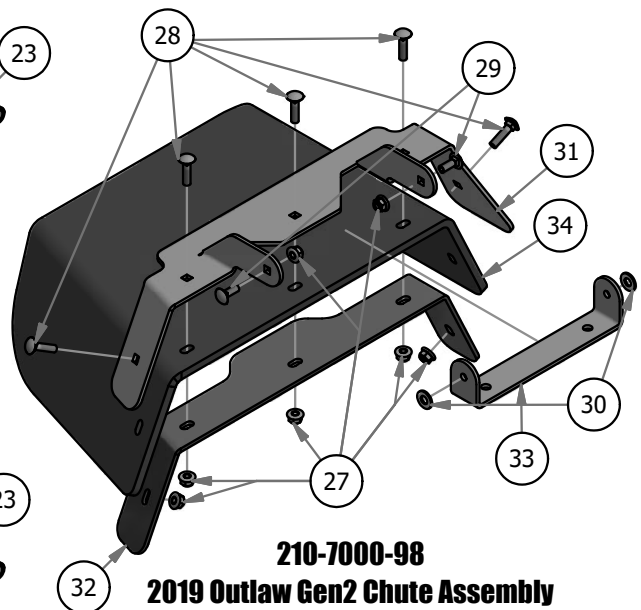

**210-7000-98
2019 Outlaw Gen2 Chute Assembly**



BAD BOY MOWERS

PARTS SECTION: DECK CONTROL ASSEMBLY

Parts List				Parts List			
ITEM	QTY	PART NUMBER	DESCRIPTION	ITEM	QTY	PART NUMBER	DESCRIPTION
8	2	013-5202-00	3/8" Nylock Flange Nut	90	1	025-0025-00	MZ Deck Idler Spacer
9	3	013-5300-00	1/2" Flange Nut	92	2	025-0033-00	2019 Deck Stop Spacer
12	1	013-7018-00	1/2" Hex Nut	94	1	026-0026-00	Knurled Pedal
16	9	013-8050-00	1/2-13 Nylon Flange Nut	100	1	028-0008-00	Dial Rod Plunger
17	2	013-9001-00	1/4-20 Hex Flange Nuts Zinc w/Serrations	101	1	028-0015-19	2019 Outlaw Gen2 Deck Height Dial Rod Assy
18	2	013-9002-00	5/16" Flange Nut	102	1	028-0026-00	2019 Outlaw Actuator - Front
40	4	017-9075-00	Pillow Block Assembly	103	1	028-0027-00	2019 Outlaw Actuator - Rear
41	2	018-0004-00	1/2 x 7 Hex Bolt Grade 5	106	1	028-6075-00	2019 Actuator Linkage - Right
45	1	018-0043-00	1/2 x 2-1/2 Carriage Bolt	107	1	028-6076-00	2019 Actuator Linkage - Left
57	1	018-2049-00	13mm Damper Ball Stud-Steering	116	1	031-0120-00	Foot Lift Upright Lever
58	1	018-2050-00	10mm Damper Ball Stud-Steering	117	1	031-0125-00	2019 Outlaw Deck Travel Lock
59	1	018-2055-00	10mm Damper Ball Stud-XP Linkage	122	4	032-5052-00	Bronze Bushing - SF - 2024-8
60	4	018-3001-00	5/8" x 5/8" Shoulder Bolt	124	1	034-1025-00	Brake Spring
61	4	018-4010-00	1/2" Nylock Nut (1/2 Jam)	136	1	044-4000-00	Seat Bracket Pin
62	1	018-4702-00	1/4-20 x 1-1/4 GR 5 Hex Bolt	137	1	045-6044-00	Foot Pedal Knob 1/2-13
64	6	018-5019-00	1/2" x 4" Bolt (Grade 8)	162	1	069-4011-00	Travel Lock Rubber Grip
66	2	018-5043-00	3/8" x 1 1/4" Carriage Bolt	165	1	070-5371-19	2019 Rigid Frame
75	1	019-0007-00	.517 Square Hole Round Washer	178	1	087-5400-00	200 lb Gas Spring- 54" Deck outlaw
78	6	019-6017-00	.630 ID Plastic Washer	179	1	087-6100-00	250lb Gas Spring - 61" Deck
84	3	019-8054-00	.505 Nylon Spacer	180	1	087-7200-00	300lb Gas Spring - 72" Deck
88	1	025-0002-00	5/8" Split Collar				

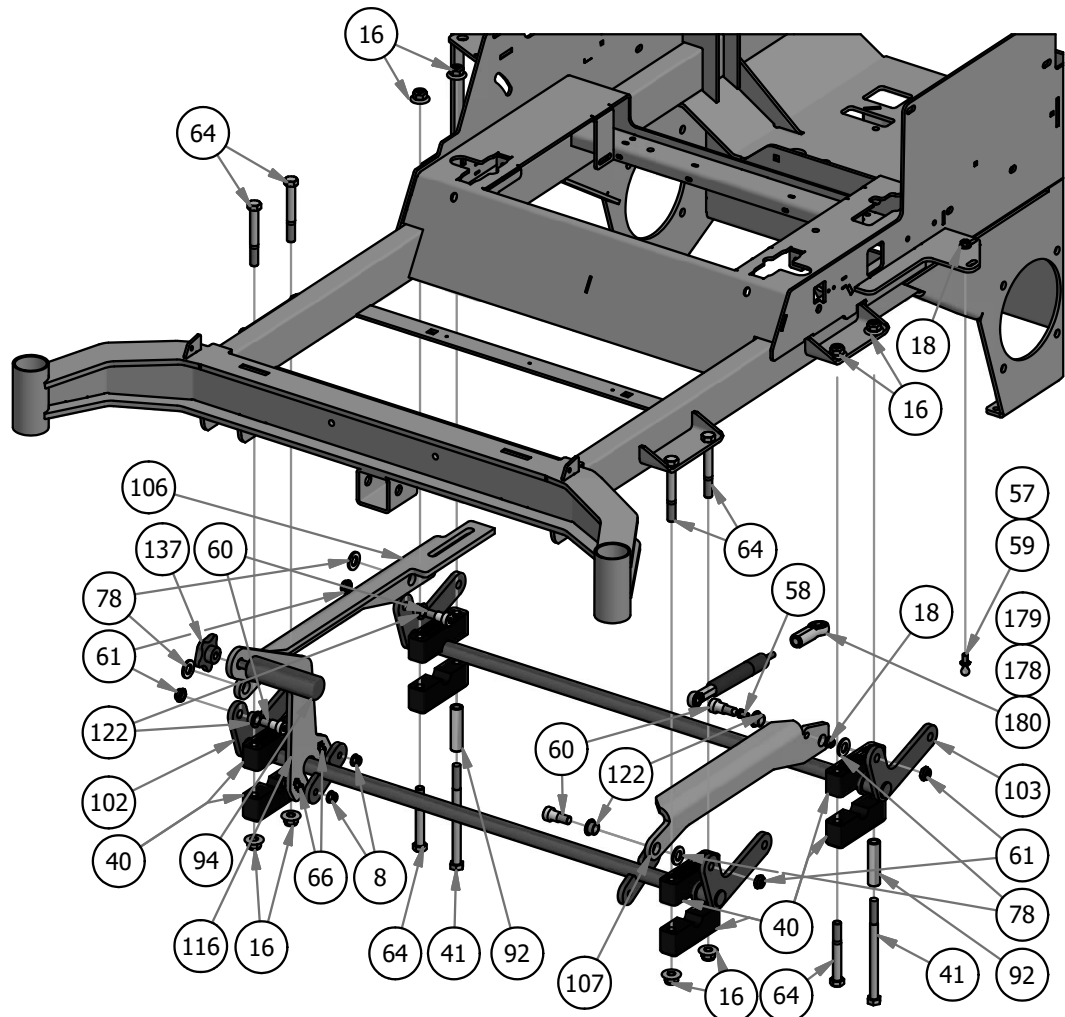



BAD BOY MOWERS

PARTS SECTION: DECK CONTROL ASSEMBLY (CONT.)

017-9075-00 Parts List				028-0015-19 Parts List			
ITEM	QTY	PART NUMBER	DESCRIPTION	ITEM	QTY	PART NUMBER	DESCRIPTION
40.1	1	017-9000-00	Two Piece Pillow Block (Male)	101.1	1	018-4011-00	3/8-24 Nylon Insert jam locknut
40.2	1	017-9025-00	Two Piece Pillow Block Strap	101.2	1	019-5029-00	3/8" Flat Washer
40.3	1	017-9050-00	Two Piece Pillow Block (Female)	101.3	1	026-1101-00	2019 Deck Height Cam
				101.4	1	028-0015-00	2019 Outlaw Gen2 Dial Rod

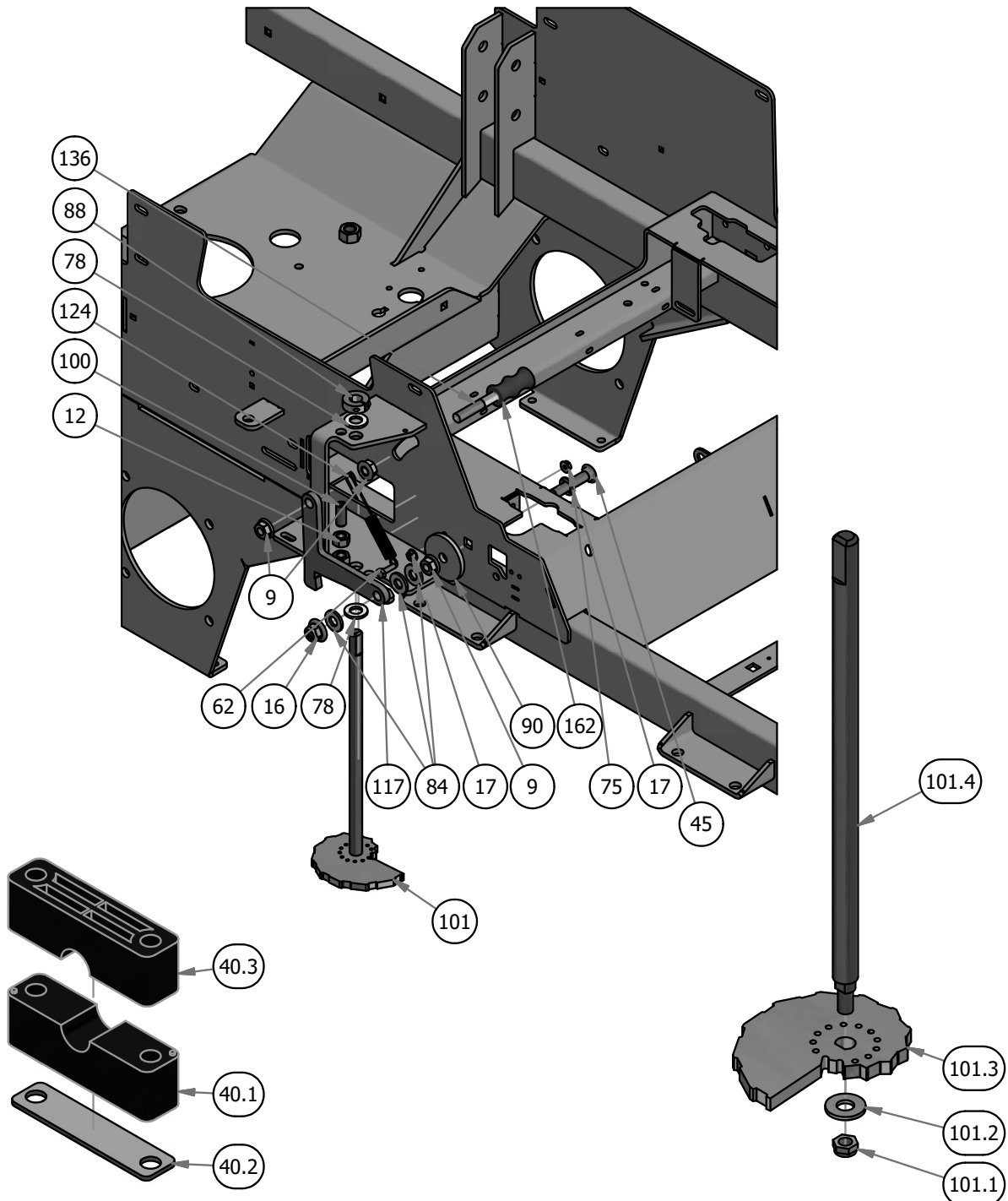

017-9075-00

Pillow Block Assembly

028-0015-19

2019 Outlaw Gen2 Deck Height Dial Rod Assy



BAD BOY MOWERS

PARTS SECTION: DRIVE ARM ASSEMBLY

Parts List				Parts List			
ITEM	QTY	PART NUMBER	DESCRIPTION	ITEM	QTY	PART NUMBER	DESCRIPTION
3	2	013-0021-00	Extruded Nut 3/8"-16 3/4" Hole Center With Patch	104	1	028-0051-00	2019 Steering Actuator Rod
13	2	013-8043-00	5/16" Nut	114	1	031-0030-19	2019 R Series RH Arm Rod Assembly
14	4	013-8047-00	5/16-18 Nylock Insert Locknut	115	1	031-0031-19	2019 R Series LH Arm Rod Assembly
16	1	013-8050-00	1/2-13 Nylon Flange Nut	118	1	031-9005-70	2019 Left Hand ADJ. Steering Arm Kit
18	6	013-9002-00	5/16" Flange Nut	119	1	031-9055-70	2019 Right Hand ADJ. Steering Arm Kit
49	8	018-1080-00	12-24x 1/2 HWH Bolt	121	2	032-0002-00	Snap-In Bushing-2019
51	4	018-2006-00	5/16 x 1 1/4 Hex Bolt	126	2	035-0003-00	2019 Outlaw Rigid Push Rod Assembly
55	4	018-2020-18	5/16-18 BHCS, TORX DRIVE	128	2	039-2160-00	2019 Arm Switch Bracket
58	4	018-2050-00	10mm Damper Ball Stud-Steering	150	2	057-5800-00	Speed Limiting Knob 3/8-16X 3"
71	1	018-6049-00	3/8" x 1" Hex Bolt	165	1	070-5371-19	2019 Rigid Frame
77	1	019-5037-00	3/8" Lock Washer	168	2	077-8073-00	Safety Switch
82	2	019-8051-00	5/16" Lock Washer	177	2	087-0001-00	Steering Damper

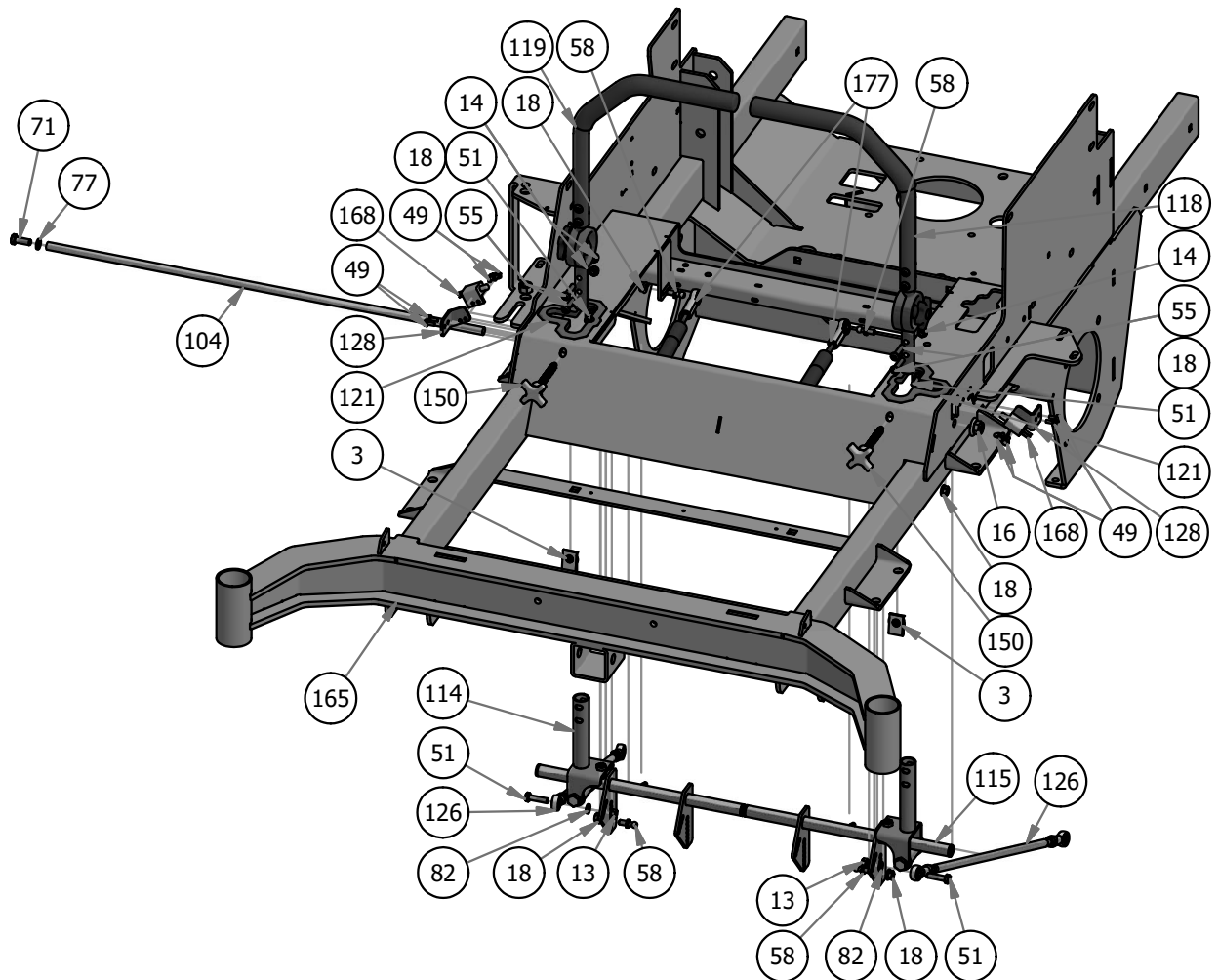



PARTS SECTION: DRIVE ARM ASSEMBLY (CONT.)

031-9055-70 Parts List				031-9005-70 Parts List			
ITEM	QTY	PART NUMBER	DESCRIPTION	ITEM	QTY	PART NUMBER	DESCRIPTION
119.1	2	013-8047-00	5/16-18 Nylock Insert Locknut	118.1	2	013-8047-00	5/16-18 Nylock Insert Locknut
119.2	2	018-2020-18	5/16-18 BHCS, TORX DRIVE	118.2	2	018-2020-18	5/16-18 BHCS, TORX DRIVE
119.3	1	018-5043-00	3/8" x 1 1/4" Carriage Bolt	118.3	1	018-5043-00	3/8" x 1 1/4" Carriage Bolt
119.4	2	031-9005-00	2019 Steering Arm Adjuster Casting	118.4	2	031-9005-00	2019 Steering Arm Adjuster Casting
119.5	1	031-9006-00	2019 Steering Arm Grip	118.5	1	031-9006-00	2019 Steering Arm Grip
119.6	1	045-5000-00	Black Knob for Adjustable Steering Arm	118.6	1	045-5000-00	Black Knob for Adjustable Steering Arm
119.7	1	069-4010-00	Black Steering Arm Grip	118.7	1	069-4010-00	Black Steering Arm Grip
031-0030-19 Parts List				031-0031-19 Parts List			
ITEM	QTY	PART NUMBER	DESCRIPTION	ITEM	QTY	PART NUMBER	DESCRIPTION
114.1	1	013-0017-00	3/8-16 Half Jam Nut	115.1	1	013-0017-00	3/8-16 Half Jam Nut
114.2	1	013-8050-00	1/2-13 Nylon Flange Nut	115.2	1	013-8050-00	1/2-13 Nylon Flange Nut
114.3	1	018-0050-00	1/2-13 x 3.25 GR 5 Hex Bolt Zinc	115.3	1	018-0050-00	1/2-13 x 3.25 GR 5 Hex Bolt Zinc
114.4	1	018-0063-00	3/8-16 x 1 Set Socket Set Screw Cup Point	115.4	1	018-0063-00	3/8-16 x 1 Set Socket Set Screw Cup Point
114.5	2	019-8054-00	.505 Nylon Spacer	115.5	2	019-8054-00	.505 Nylon Spacer
114.6	1	031-0014-00	Drive Arm Pivot	115.6	1	031-0014-00	Drive Arm Pivot
114.7	1	031-0030-00	2019 Drive Arm Actuator right	115.7	1	031-0031-00	2019 Drive Arm Actuator left

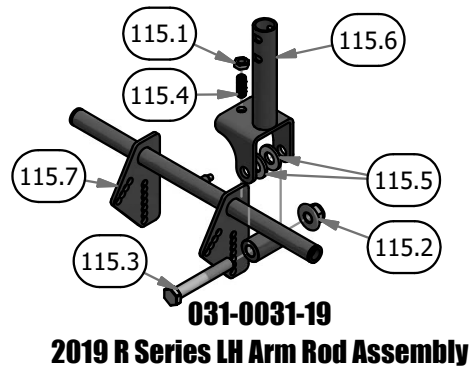
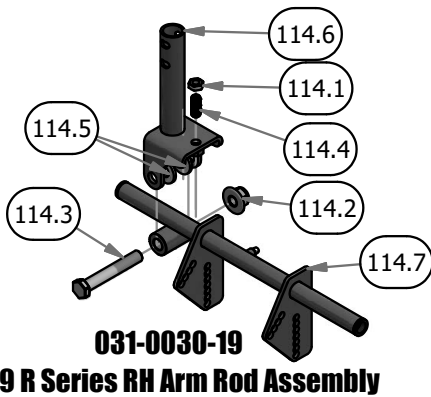
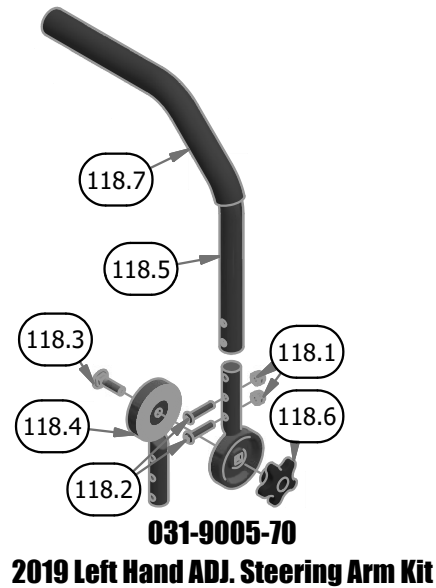
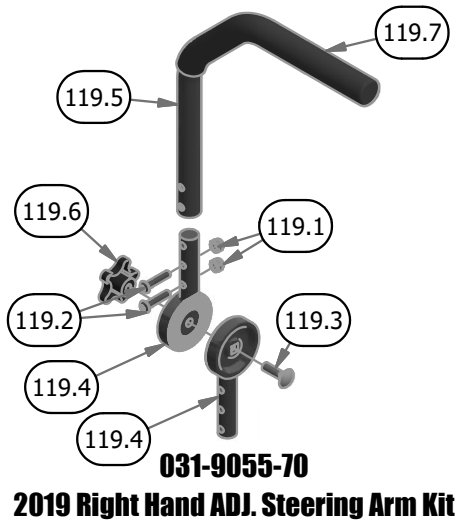

035-0003-00 Parts List			
ITEM	QTY	PART NUMBER	DESCRIPTION
126.1	1	013-6050-00	5/16" LH Fine Threaded Jam Nut
126.2	1	013-6051-00	3/8" Fine Threaded Jam Nut
126.3	1	035-0003-01	2019 Outlaw Rigid Push Rod
126.4	1	048-3000-00	Spherical Rod End - Outlaw
126.5	1	048-3002-00	Spherical Rod End - Outlaw

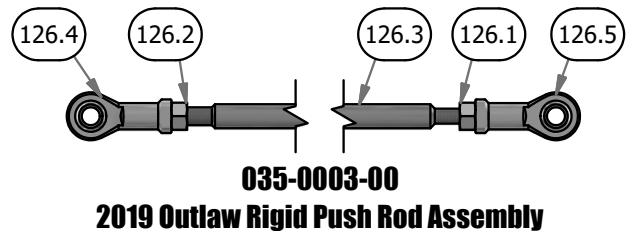



BAD BOY MOWERS

PARTS SECTION: TANKS & BATTERY

Parts List				Parts List			
ITEM	QTY	PART NUMBER	DESCRIPTION	ITEM	QTY	PART NUMBER	DESCRIPTION
6	4	013-2050-00	1/4-20 Nylon Insert flange Nut	142	1	051-2019-32	2019 Rebel Rogue Renegade Fuel Line for Kawasaki
11	1	013-6051-00	3/8" Fine Threaded Jam Nut	146	1	054-8017-00	Choke
15	5	013-8049-00	5/16" Nylon Flange Nut	147	1	054-8019-00	Choke for 36Hp Vanguard & FX1000 Kawasaki
17	4	013-9001-00	1/4-20 Hex Flange Nuts Zinc w/Serrations	148	1	055-8021-75	Outlaw Throttle Cable
52	11	018-2007-00	5/16" x 1" Bolt	149	1	055-8022-00	Throttle Cable for 36Hp Vanguard & FX1000 Kawasaki
53	4	018-2010-00	10-32 x 3/8" Button Socket Head Bolt	153	1	064-5301-01	14" Red Battery Cable-Base Outlaw
54	1	018-2012-00	1/4" x 1/2" BS C/S 18-8 SS	154	2	064-8056-00	Long Brake Cable
70	2	018-5344-00	5/16" x 2 1/2" Bolt	157	2	067-8085-19	2019 Rebel Hydro Tank Assembly
73	2	018-8052-00	1/4" x 3/4" Hex Bolt	158	1	067-9950-50	2019 Right Rebel, Rogue, Renegade Fuel Tank (GAS)
80	4	019-8040-00	1/4" x 3/4" Carriage Bolt	159	1	067-9960-50	2019 Left Rebel, Rogue, Renegade Fuel Tank (GAS)
81	8	019-8044-00	5/16" Flat Washer	160	1	068-8049-00	Battery
82	8	019-8051-00	5/16" Lock Washer	161	1	069-0001-00	2019 Brake Handle Assembly
91	2	025-0027-00	2019 Outlaw Brake Handle Spacer .625 x 1.5	165	1	070-5371-19	2019 Rigid Frame
131	8	040-6081-00	3/16 x .48 Christmas Tree Nylon Black	169	1	077-9002-00	2019 Rigid Deck Dial 1.5 to 5.5
134	1	042-9000-00	Ignition Key	171	1	079-3481-19	Rebel/Rogue Control Panel Assy
135	1	043-8929-00	Hold Down Assembly	174	1	086-0005-00	Starter Cable
140	1	051-2019-22	2019 Rebel Rogue Renegade Fuel Line for Vanguard & Yamaha	175	1	086-2050-19	2019 Wiring Harness-Rebel/Rogue
141	1	051-2019-28	2019 Rebel Rogue Renegade Fuel Line for Kohler				

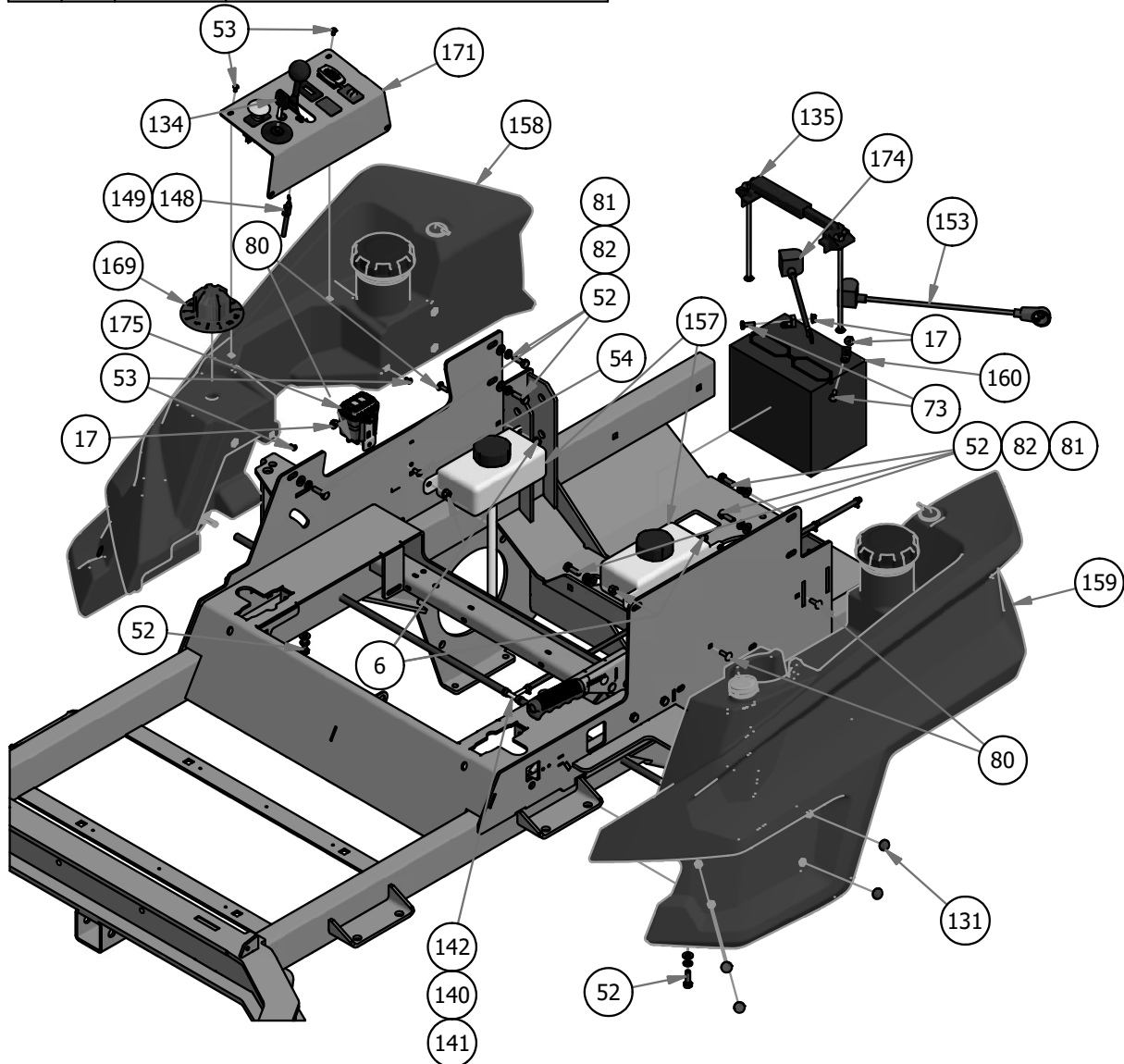



BAD BOY MOWERS

PARTS SECTION: TANKS & BATTERY (CONT.)

051-2019-22 Parts List				051-2019-32 Parts List			
ITEM	QTY	PART NUMBER	DESCRIPTION	ITEM	QTY	PART NUMBER	DESCRIPTION
140.1	1	051-8067-22	1/4" Fuel Line Hose	142.1	1	051-8067-32	1/4" Fuel Line Hose
140.2	2	051-8075-26	5/16" fuel line hose	142.2	2	051-8075-26	5/16" fuel line hose
140.3	2	072-8068-00	5/16 Fuel Line Clamp	142.3	2	072-8068-00	5/16 Fuel Line Clamp
140.4	2	072-8069-00	1/4 Fuel Hose Clamp	142.4	2	072-8069-00	1/4 Fuel Hose Clamp
140.5	1	073-8069-00	5/16 x 5/16 x 1/4 Fuel Line T	142.5	1	073-8069-00	5/16 x 5/16 x 1/4 Fuel Line T
051-2019-28 Parts List				067-8085-19 Parts List			
ITEM	QTY	PART NUMBER	DESCRIPTION	ITEM	QTY	PART NUMBER	DESCRIPTION
141.1	1	051-8067-28	1/4" Fuel Line Hose	157.1	1	051-0019-00	5/8 Braided Hose
141.2	2	051-8075-26	5/16" fuel line hose	157.2	1	066-5050-00	Hydraulic Tank Cap
141.3	2	072-8068-00	5/16 Fuel Line Clamp	157.3	1	067-8085-00	Expansion Tank Outlaw
141.4	2	072-8069-00	1/4 Fuel Hose Clamp	157.4	2	072-8074-00	5/8 Wire Clamp-Outlaw Only
141.5	1	073-8069-00	5/16 x 5/16 x 1/4 Fuel Line T				

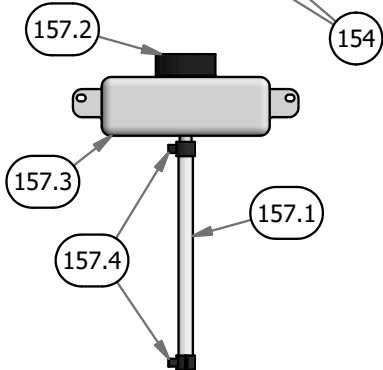
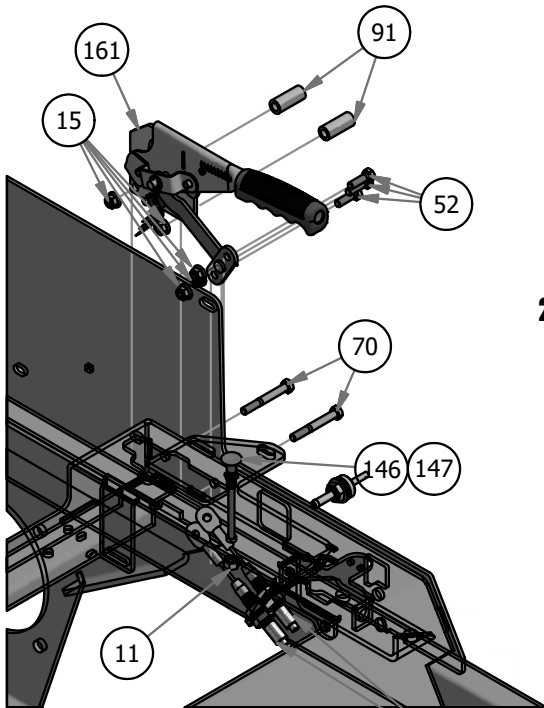

067-8085-19
2019 Rebel Hydro Tank Assembly

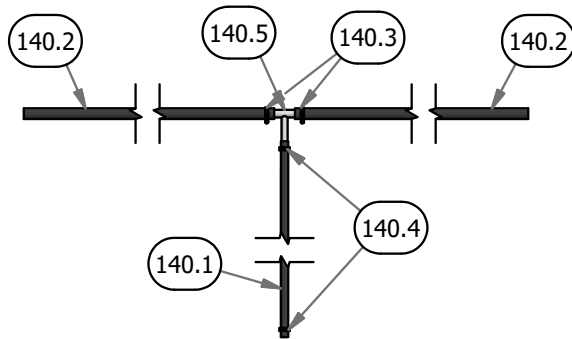

051-2019-22
2019 Rebel Rogue Renegade Fuel Line for Vanguard & Yamaha

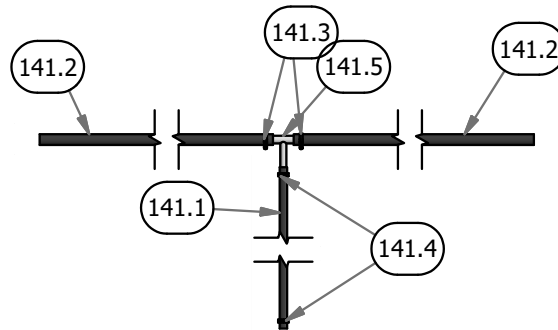

051-2019-28
2019 Rebel Rogue Renegade Fuel Line for Kohler

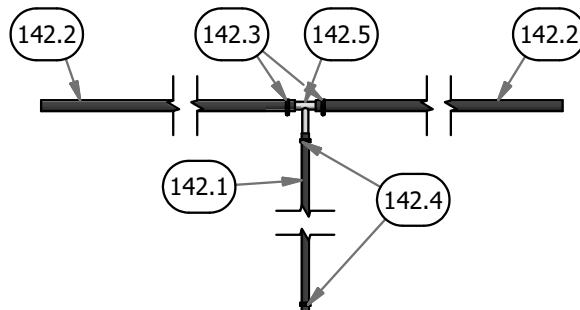

051-2019-32
2019 Rebel Rogue Renegade Fuel Line for Kawasaki



BAD BOY MOWERS

PARTS SECTION: TANKS & BATTERY (CONT.)

067-9950-50 Parts List				067-9960-50 Parts List			
ITEM	QTY	PART NUMBER	DESCRIPTION	ITEM	QTY	PART NUMBER	DESCRIPTION
154.1	1	067-6054-00	Roll Over Valve Grommet	155.1	1	067-4090-00	Fuel Gauge with Grommet
154.2	1	067-6070-00	Rollover Valve	155.2	1	067-6054-00	Roll Over Valve Grommet
154.3	1	067-9901-00	Fuel Pick-up	155.3	1	067-6056-00	Fuel Gauge Grommet
154.4	1	067-9904-00	Fuel Cap	155.4	1	067-6070-00	Rollover Valve
079-3481-19 Parts List				086-205-19 Parts List			
ITEM	QTY	PART NUMBER	DESCRIPTION	ITEM	QTY	PART NUMBER	DESCRIPTION
167.1	2	013-5019-00	10-24 Nylon Insert Locknut Zinc Orange Nylon	171.1	1	086-1202-01	Relay Block Cover Replacement Kit
167.2	2	018-1040-00	Light Plug	171.2	4	086-1202-19	Relay
167.3	2	018-5200-00	10-24 X 5/8 BS Button Head Bolt	043-8929-00 Parts List			
167.4	1	055-2012-00	Universal Throttle	ITEM	QTY	PART NUMBER	DESCRIPTION
167.5	1	055-2013-00	Throttle Knob	135.1	2	013-8051-00	1/4" Wing Nut
167.6	1	056-8058-00	PTO Switch	135.2	2	018-8050-00	1/4-20 X 8 Carriage Bolt
167.7	1	077-2076-00	USB Port	135.3	1	043-8929-00	Battery Hold Down
167.8	1	077-8076-00	Ignition Switch				
167.9	1	079-3481-00	2019 Outlaw Control Panel				
167.10	1	083-4013-00	Tachometer				
167.11	1	089-1000-00	Oil Light				

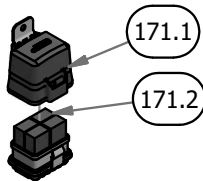

086-2050-19

2019 Wiring Harness-Rebel/Rogue

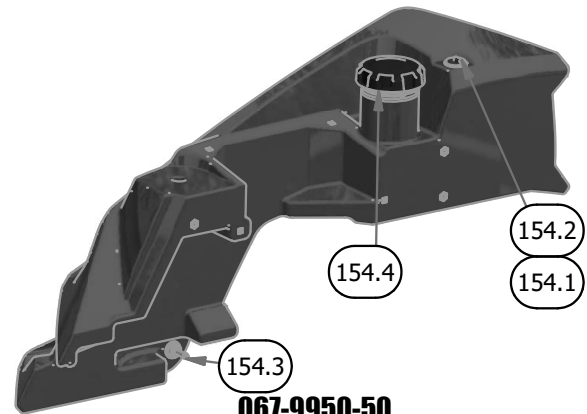

067-9950-50

2019 Right Rebel, Rogue, Renegade Fuel Tank (GAS)



043-8929-00

Hold Down Assembly

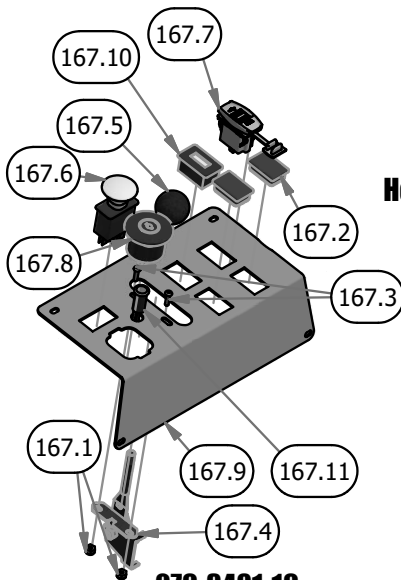

079-3481-19

Rebel/Rogue Control Panel Assy

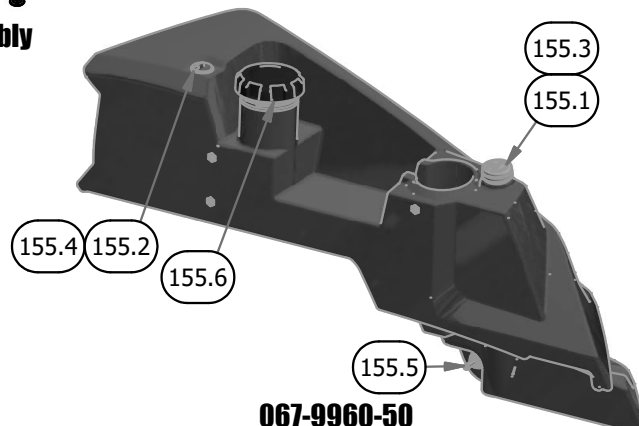

067-9960-50

2019 Left Rebel, Rogue, Renegade Fuel Tank (GAS)



BAD BOY MOWERS

PARTS SECTION: TRANSAXLE ASSEMBLY

Parts List				Parts List			
ITEM	QTY	PART NUMBER	DESCRIPTION	ITEM	QTY	PART NUMBER	DESCRIPTION
7	10	013-3000-00	Acorn Lug Nut	125	1	034-9050-00	Deck spring big diameter
8	6	013-5202-00	3/8" Nylock Flange Nut	126	2	035-0003-00	2019 Outlaw Rigid Push Rod Assembly
10	2	013-6014-00	3/8-16 Hex Nuts Zinc	127	2	039-2135-00	2015 Outlaw Brake Adapter (4400 Transaxles Only)
12	2	013-7018-00	1/2" Hex Nut	129	1	039-6945-03	2019 Rebel Pump Idler
15	6	013-8049-00	5/16" Nylon Flange Nut	132	1	041-8050-00	2019 Rebel Pump Belt
22	1	014-5070-00	2019 Rigid Fan Guard	138	1	050-1000-00	4400 Transaxle - Left Hand
50	1	018-2004-50	All Thread-Pump Idler Tensioner	134.1	1	034-9080-00	Transaxle Spring
51	4	018-2006-00	5/16 x 1 1/4 Hex Bolt	134.2	1	050-1025-00	Fan/Pulley Kit for 4400 Transaxle
52	2	018-2007-00	5/16" x 1" Bolt	134.3	1	050-2082-00	Hub/Stud Kit for 4400 Transaxle
56	8	018-2030-00	1/2" x 1" Hex Bolt	134.4	1	050-8003-00	Seal Kit for 4400 Transaxle
61	1	018-4010-00	1/2" Nylock Nut (1/2 Jam)	134.5	1	063-1070-00	Hydro Filter for 4400 Transaxle
65	2	018-5040-00	3/8" x 1 1/4" Hex Bolt	139	1	050-1050-00	4400 Transaxle - Right Hand
66	6	018-5043-00	3/8" x 1 1/4" Carriage Bolt	135.1	1	034-9080-00	Transaxle Spring
76	8	019-5007-00	1/2" Lock Washer Zinc	139.2	1	050-1025-00	Fan/Pulley Kit for 4400 Transaxle
77	2	019-5037-00	3/8" Lock Washer	139.3	1	050-2082-00	Hub/Stud Kit for 4400 Transaxle
86	2	022-4100-00	24x12-12 Reaper Turf Tire & Wheel Assembly	139.4	1	050-8003-00	Seal Kit for 4400 Transaxle
86.2	2	022-4095-00	24x12-12 Reaper Turf Tire	139.5	1	063-1070-00	Hydro Filter for 4400 Transaxle
86.1	2	022-4070-00	12x12" Black Wheel For 2015 Outlaw	154	2	064-8056-00	Long Brake Cable
99	1	026-2240-00	2019 Outlaw Rigid Skid Plate	165	1	070-5371-19	2019 Rigid Frame



022-4100-00
24x12-12 Reaper Turf Tire & Wheel Assembly

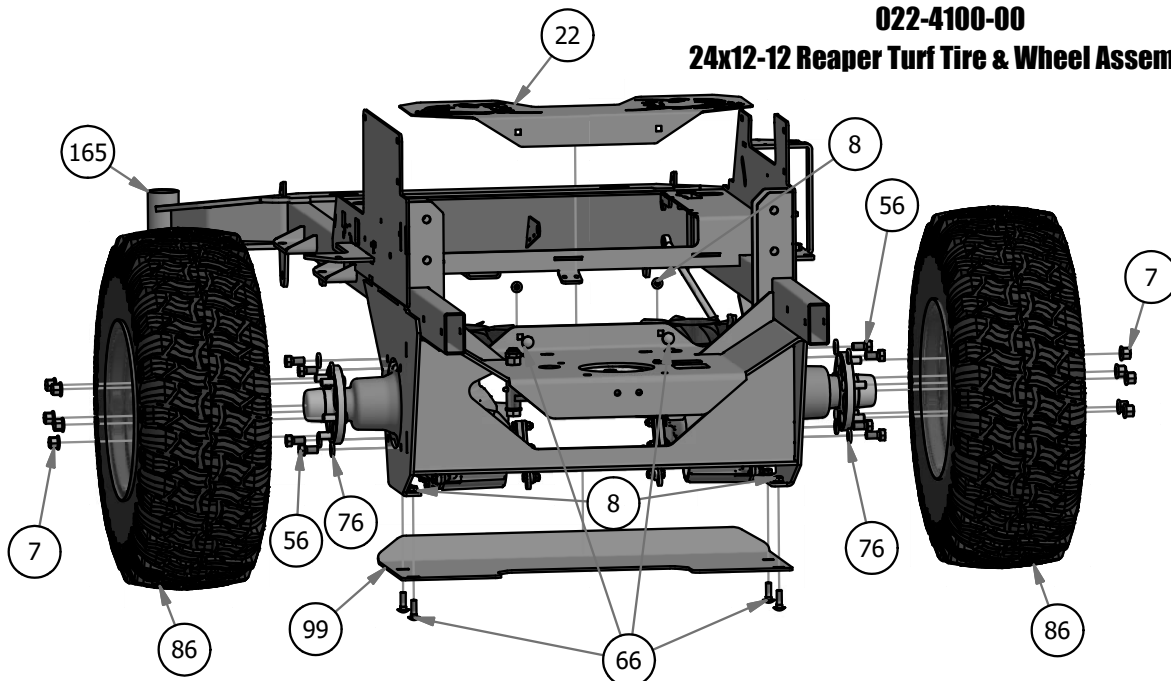



BAD BOY MOWERS

PARTS SECTION: TRANSAXLE ASSEMBLY (CONT.)

039-6945-03 Parts List			
ITEM	QTY	PART NUMBER	DESCRIPTION
129.1	1	013-5301-00	5/8-11 Nylon Insert Jam Half Nut
129.2	1	013-8050-00	1/2-13 Nylon Flange Nut
129.3	1	018-5309-00	5/8-11 X 4.5 GR 5 Hex Bolts Zinc
129.4	1	018-6036-00	1/2" x 2 3/4" Hex Bolt
129.5	2	019-6017-00	.630 ID Plastic Washer
129.6	1	025-7020-00	5/8" x 1" Collar W/One Set Screw
129.7	1	025-7036-00	1/2 x 1/2 Spacer
129.8	1	033-6001-00	4 3/4" Idler Pulley
129.9	1	039-6945-00	Deck Idler

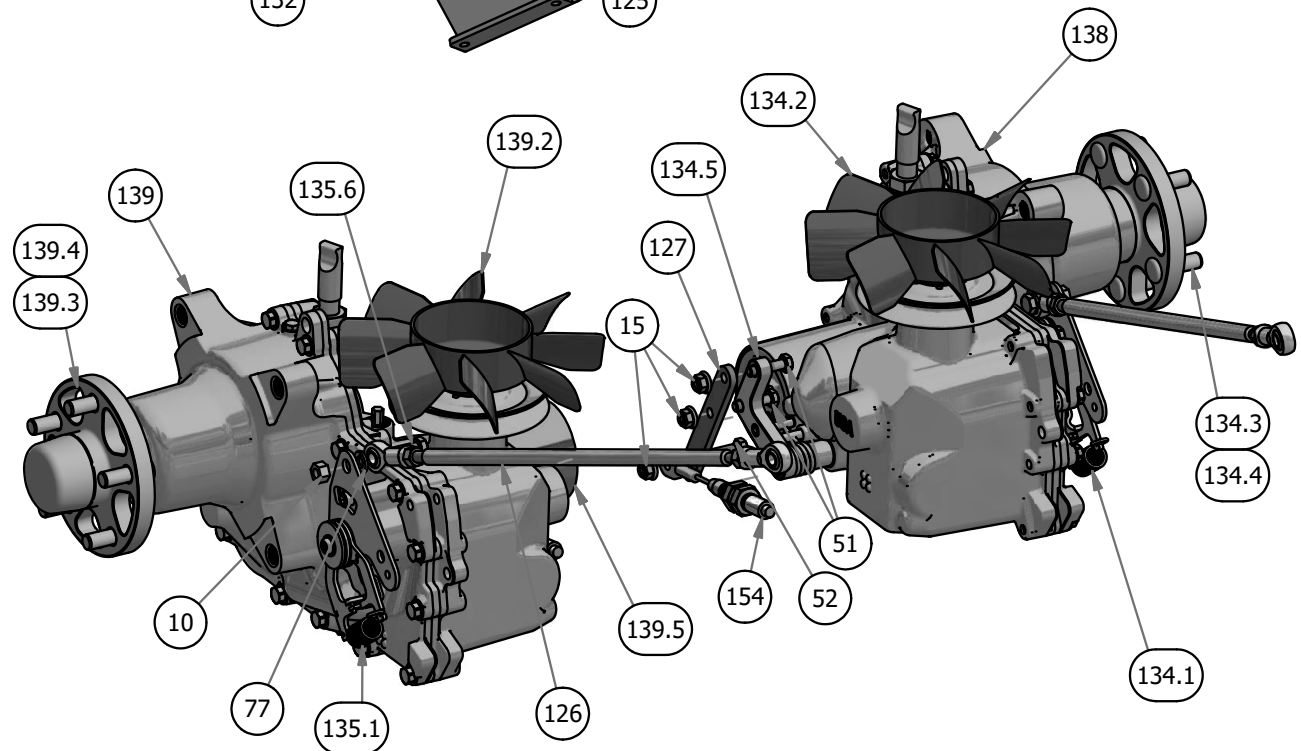
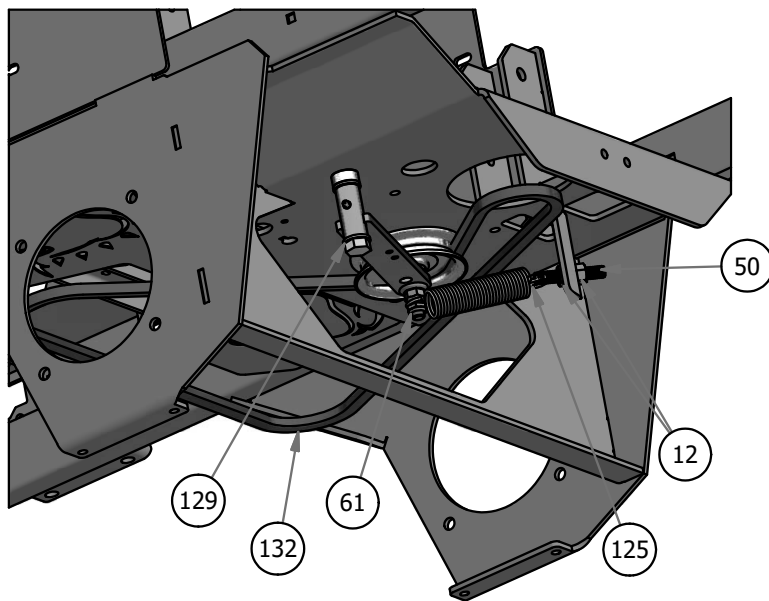
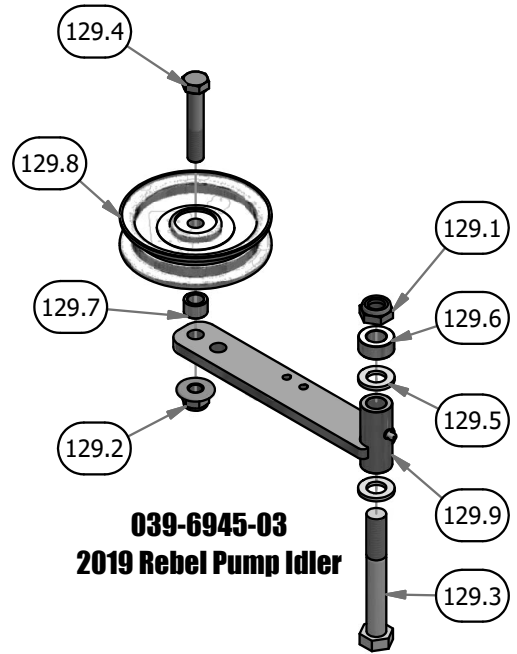



BAD BOY MOWERS

PARTS SECTION: COVERS & SEAT PAN ASSEMBLY

Parts List				Parts List			
ITEM	QTY	PART NUMBER	DESCRIPTION	ITEM	QTY	PART NUMBER	DESCRIPTION
2	4	013-0005-00	1/2" Center Lock Nut	97	1	026-2221-00	2019 Vertical Rear Cover Tailgate Plate
4	4	013-0054-00	1/4-20 Cage Nut	98	1	026-2230-00	2019 Outlaw Adjustable Foot Plate
6	2	013-2050-00	1/4-20 Nylon Insert flange Nut	105	1	028-0090-00	Seat Latch Rod Assembly
8	10	013-5202-00	3/8" Nylock Flange Nut	108	6	029-4010-00	Button Bumper
15	11	013-8049-00	5/16" Nylon Flange Nut	109	1	029-8000-00	2017 XP Bumper
18	4	013-9002-00	5/16" Flange Nut	111	6	030-3050-00	#10 x 1/2" Self Tapping Screw
20	1	013-9005-00	5/16-18 Nylock Jam Nut 1/2 Nut	113	2	030-7040-00	1/4 x 1 Hex Head Tek screw
23	2	014-9003-00	1 1/2 x 3 Frame Plug	120	2	032-0001-00	2019 Bad Boy X Cylindrical Seat Mount
43	2	018-0024-00	M6-1.0 X 16MM Hex Bolt	124	1	034-1025-00	Brake Spring
46	4	018-0044-00	3/8" x 2 1/2" Carriage Bolt	130	14	040-6080-00	Ratchet Fastener
47	4	018-0050-00	1/2-13 X 3.25 Hex Bolt - Grade 5	155	1	064-8081-00	Seat Cable
52	1	018-2007-00	5/16" x 1" Bolt	156	1	067-0020-19	2019 Outlaw EPA Cannister Assembly
63	1	018-4703-00	5/16" x 1 1/4" Carriage Bolt	165	1	070-5371-19	2019 Rigid Frame
67	6	018-5044-00	3/8" x 1" Carriage Bolt	166	1	071-5060-18	2019 Rebel Seat
73	4	018-8052-00	1/4" x 3/4" Hex Bolt	167	1	071-5065-00	2019 Renegade Seat (Kawasaki FX1000 Only)
74	3	018-8065-00	5/16" x 1" Carriage Bolt	170	1	079-3155-00	2019 Outlaw Floorboard
79	6	019-6042-00	.360 ID Plastic Washer	172	1	081-0050-00	OUTLAW2019_FLOORMAT
80	2	019-8040-00	1/4" x 3/4" Carriage Bolt	173	1	081-0051-00	FLOORMAT_OUTLAW_2019
95	1	026-2019-00	2019 Outlaw Seat Plate	181	1	089-0006-00	2019 2X2 Folding ROPS
96	2	026-2219-00	2019 Rebel Rear Cover Side Plate				

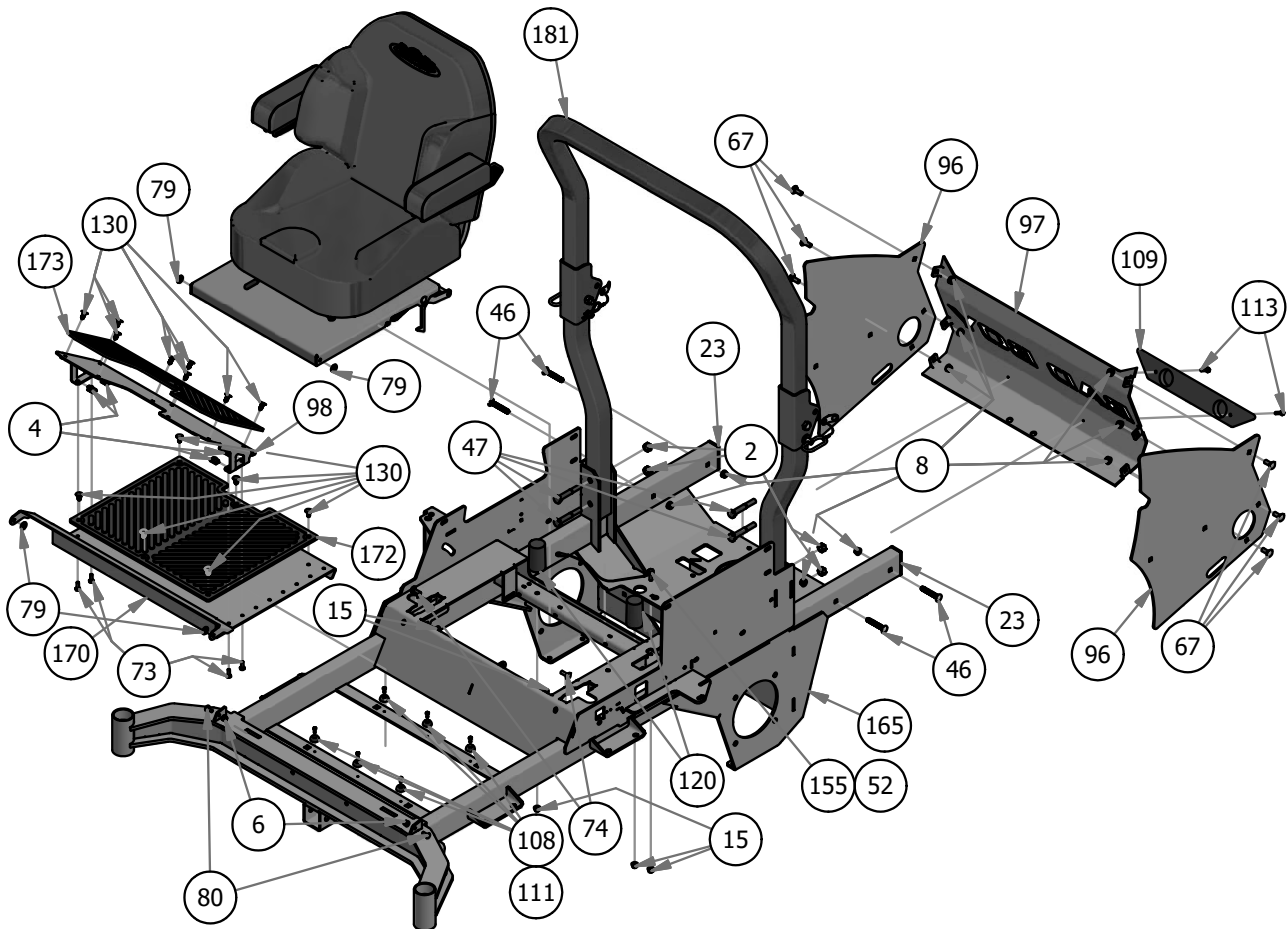



BAD BOY MOWERS

PARTS SECTION: COVERS & SEAT PAN ASSEMBLY (CONT.)

071-5060-00 Parts List				067-0020-19 Parts List			
ITEM	QTY	PART NUMBER	DESCRIPTION	ITEM	QTY	PART NUMBER	DESCRIPTION
166.1	1	071-5015-00	Extreme/XP Outlaw Seat Rails (Pair)	156.1	1	067-0020-00	Carbon Canister
166.2	1	071-5069-00	Extreme/XP Outlaw Seat Arm Rest (Pair)	156.2	2	072-8073-00	3/16" Vinyl Hose Clamp
166.3	1	071-5068-00	Extreme/XP Outlaw Seat Cushion-Bottom	156.3	6	072-8070-00	3/16 Vinyl Clamp
166.4	1	071-5067-00	Extreme/XP Outlaw Seat Cushion-Back	156.4	1	051-2025-66	3/16" Vinyl Tubing, 66" Long
166.5	1	071-8061-00	Seat Switch	156.5	3	051-8072-38	1/4" Vinyl Tubing 38" Long
				156.6	1	073-8068-00	fuel line T

071-5065-00 Parts List			
ITEM	QTY	PART NUMBER	DESCRIPTION
167.1	1	071-5065-02	Seat Belt
167.2	1	071-5065-03	Backrest Cushion
167.3	1	071-5065-04	Seat Cushion
167.4	1	071-5065-05	Slave & Adjuster
167.5	1	071-5065-06	Arm Rest Kit
167.6	1	071-5065-07	Seat Switch

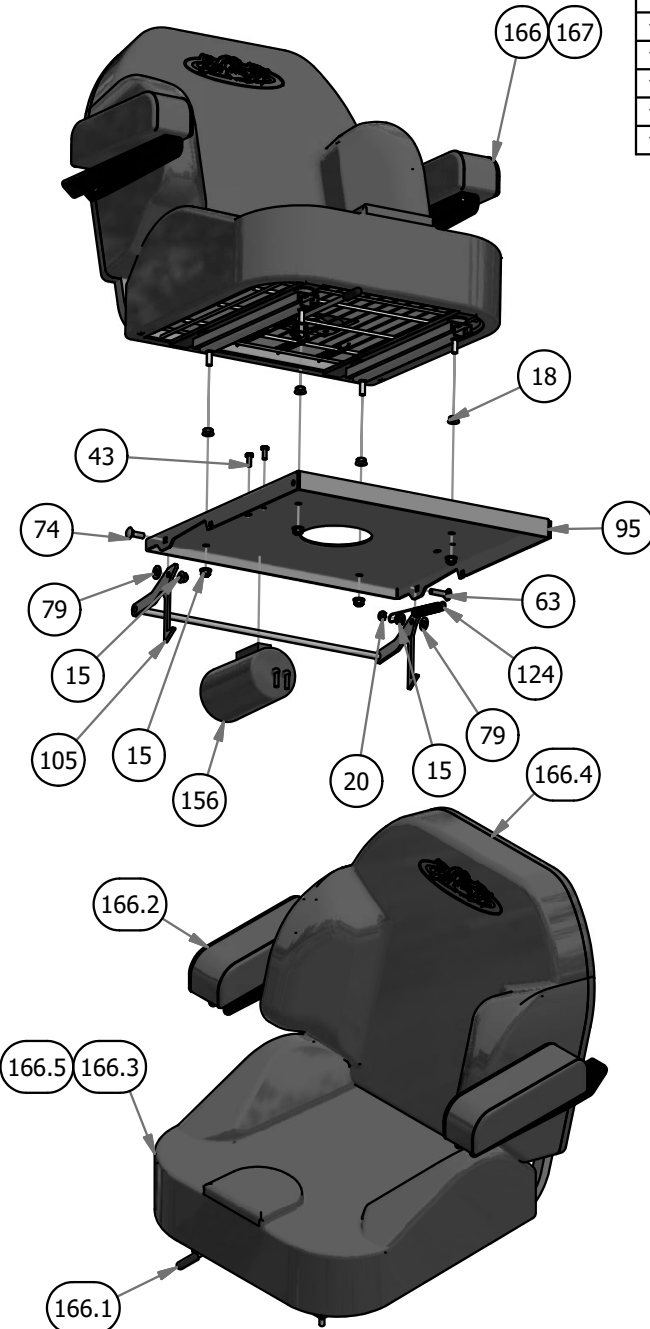

071-5060-00
2015 Extreme/XP Outlaw Seat

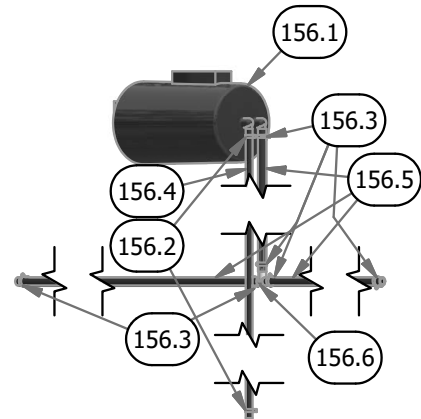

067-0020-19
2019 Outlaw EPA Cannister Assembly

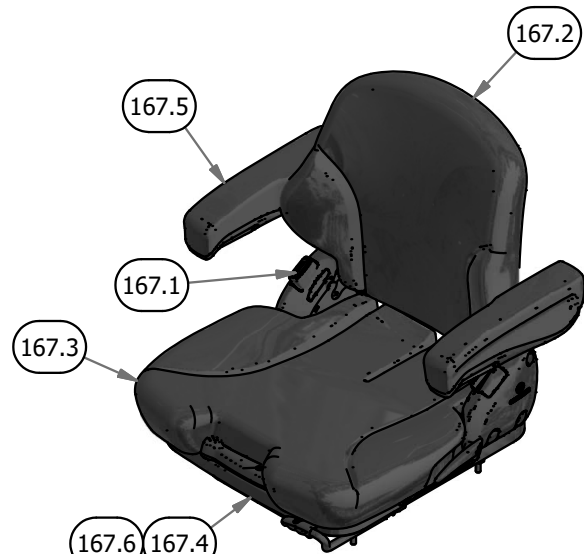

071-5065-00
2019 Renegade Seat
Kawasaki FX1000 Only



BAD BOY MOWERS

PARTS SECTION: ENGINE - 747cc KOHLER COMMAND

Parts List				Parts List			
ITEM	QTY	PART NUMBER	DESCRIPTION	ITEM	QTY	PART NUMBER	DESCRIPTION
5	4	013-0075-00	M8-1.25 Zinc Nut	82	4	019-8051-00	5/16" Lock Washer
32	1	015-1013-00	2019 Rebel Kohler CV752 Muffler	83	1	019-8053-00	7/16" Lock Washer
36	2	015-2751-00	Exhaust Gasket	123	1	033-5035-00	4 3/4 Motor Pulley
38	1	015-7520-00	Kohler Command Engine	132	1	041-8050-00	2019 Rebel Pump Belt
35.1	2	015-8000-00	Spark Plug	133	1	042-5020-00	1/4 x 2 Square key Stock
35.2	1	063-5001-00	25/26 HP Kohler Fuel Filter	144	1	051-5403-00	Oil drain Hose for Yamaha
35.3	1	063-5400-00	Oil Filter	153	1	064-5301-01	14" Red Battery Cable-Base Outlaw
35.4	1	063-8019-00	Canister Air Filter- Outer	163	1	070-1000-00	Clutch Assembly
35.5	1	063-8020-00	Canister Air Filter- Inner	164	1	070-2000-00	Clutch Pigtail
48	4	018-1075-00	3/8 x 1 1/8 bolt	165	1	070-5371-19	2019 Rigid Frame
68	1	018-5300-00	7/16" x 2 1/2" Hex Bolt	174	1	086-0005-00	Starter Cable

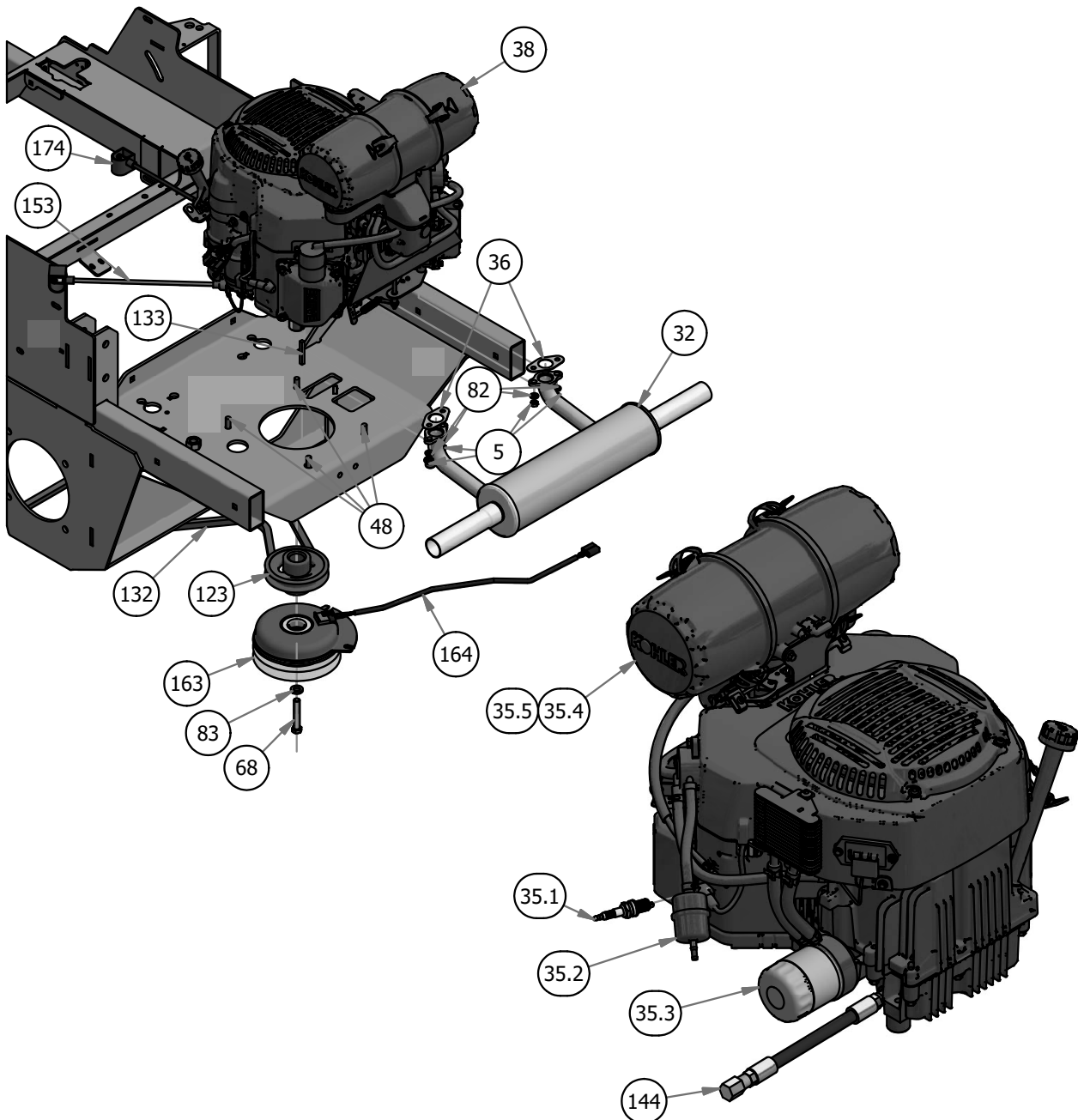



BAD BOY MOWERS

PARTS SECTION: ENGINE - 824cc YAMAHA

Parts List				Parts List			
ITEM	QTY	PART NUMBER	DESCRIPTION	ITEM	QTY	PART NUMBER	DESCRIPTION
5	4	013-0075-00	M8-1.25 Zinc Nut	82	4	019-8051-00	5/16" Lock Washer
26	1	015-0050-01	O2 Sensor Plug	83	1	019-8053-00	7/16" Lock Washer
27	2	015-0053-01	Exhaust Gasket for yamaha	123	1	033-5035-00	4 3/4 Motor Pulley
28	1	015-0076-00	Carbureted 27.5hp Yamaha Engine	132	1	041-8050-00	2019 Rebel Pump Belt
27.1	1	015-0053-02	Oil Filter	133	1	042-5020-00	1/4 x 2 Square key Stock
27.2	2	015-0053-06	Yamaha Spark Plug	144	1	051-5403-00	Oil drain Hose for Yamaha
27.3	1	015-0053-21	Yamaha Fuel Filter	153	1	064-5301-01	14" Red Battery Cable-Base Outlaw
27.4	1	063-8019-00	Canister Air Filter- Outer	163	1	070-1000-00	Clutch Assembly
27.5	1	063-8020-00	Canister Air Filter- Inner	164	1	070-2000-00	Clutch Pigtail
34	1	015-1015-00	Muffler for 27Hp Yamaha	165	1	070-5371-19	2019 Rigid Frame
48	4	018-1075-00	3/8 x 1 1/8 bolt	174	1	086-0005-00	Starter Cable
68	1	018-5300-00	7/16" x 2 1/2" Hex Bolt				

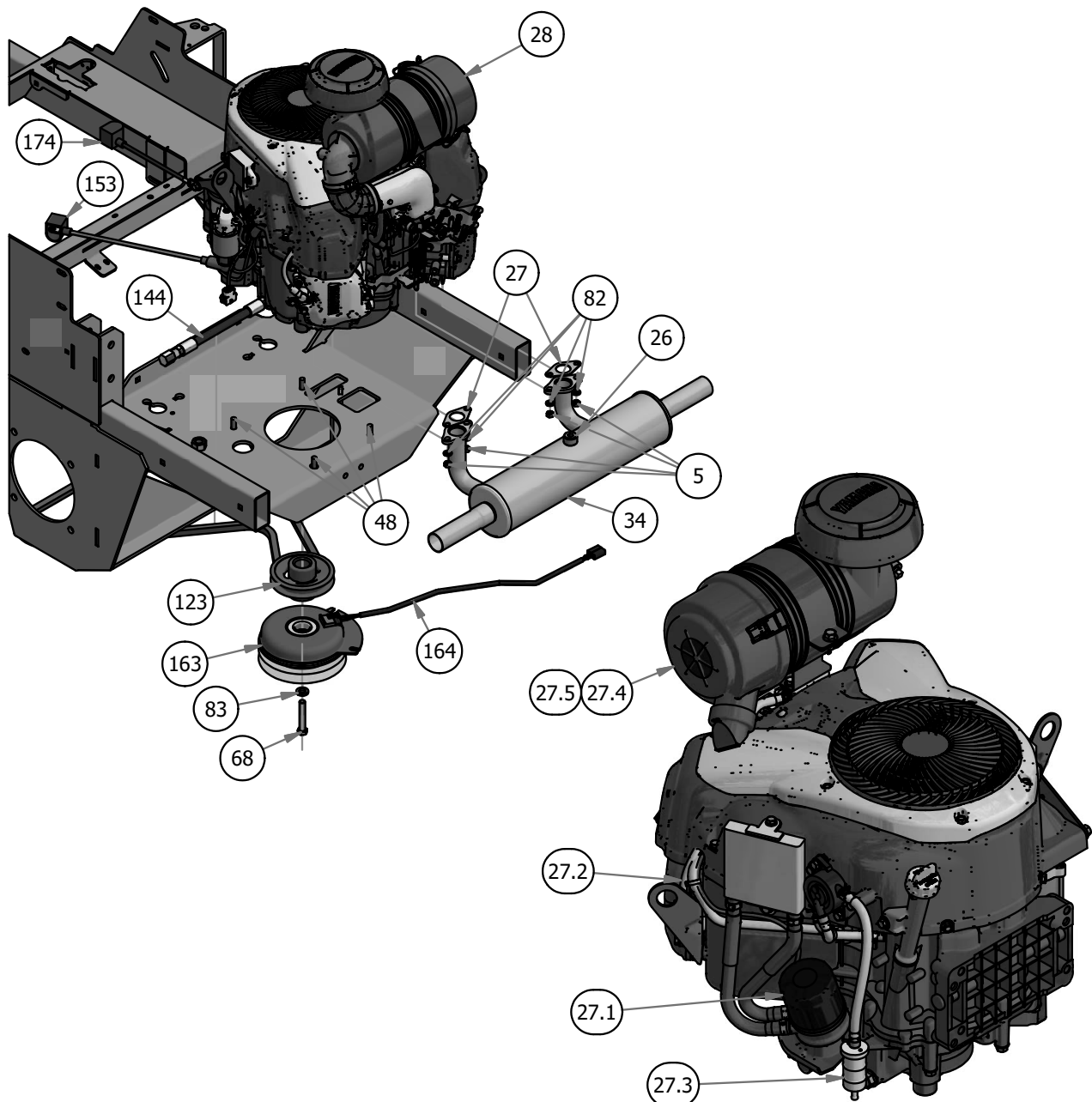



BAD BOY MOWERS

PARTS SECTION: ENGINE - 993cc VANGUARD

Parts List				Parts List			
ITEM	QTY	PART NUMBER	DESCRIPTION	ITEM	QTY	PART NUMBER	DESCRIPTION
24	2	015-0025-00	Exhaust Gasket for 23 Vanguard	123	1	033-5035-00	4 3/4 Motor Pulley
33	1	015-1014-00	Muffler for 36Hp Vanguard	132	1	041-8050-00	2019 Rebel Pump Belt
37	1	015-3600-00	993cc Vanguard Engine	133	1	042-5020-00	1/4 x 2 Square key Stock
34.1	2	015-8000-00	Spark Plug	143	1	051-5402-00	14 mm Oil drain Hose 993cc Vanguard
34.2	1	063-6000-00	Universal Inline Fuel Filter	153	1	064-5301-01	14" Red Battery Cable-Base Outlaw
34.3	1	063-8018-00	Oil Filter	163	1	070-1000-00	Clutch Assembly
34.4	1	063-8019-00	Canister Air Filter- Outer	164	1	070-2000-00	Clutch Pigtail
37.5	1	063-8020-00	Canister Air Filter- Inner	165	1	070-5371-19	2019 Rigid Frame
42	4	018-0017-00	Torx Bolt-Exhaust	174	1	086-0005-00	Starter Cable
48	4	018-1075-00	3/8 x 1 1/8 bolt	176	1	086-9001-19	2019 Harness Adaptor - 36 Vanguard Carberated
68	1	018-5300-00	7/16" x 2 1/2" Hex Bolt	26	1	015-0050-01	O2 Sensor Plug
83	1	019-8053-00	7/16" Lock Washer				

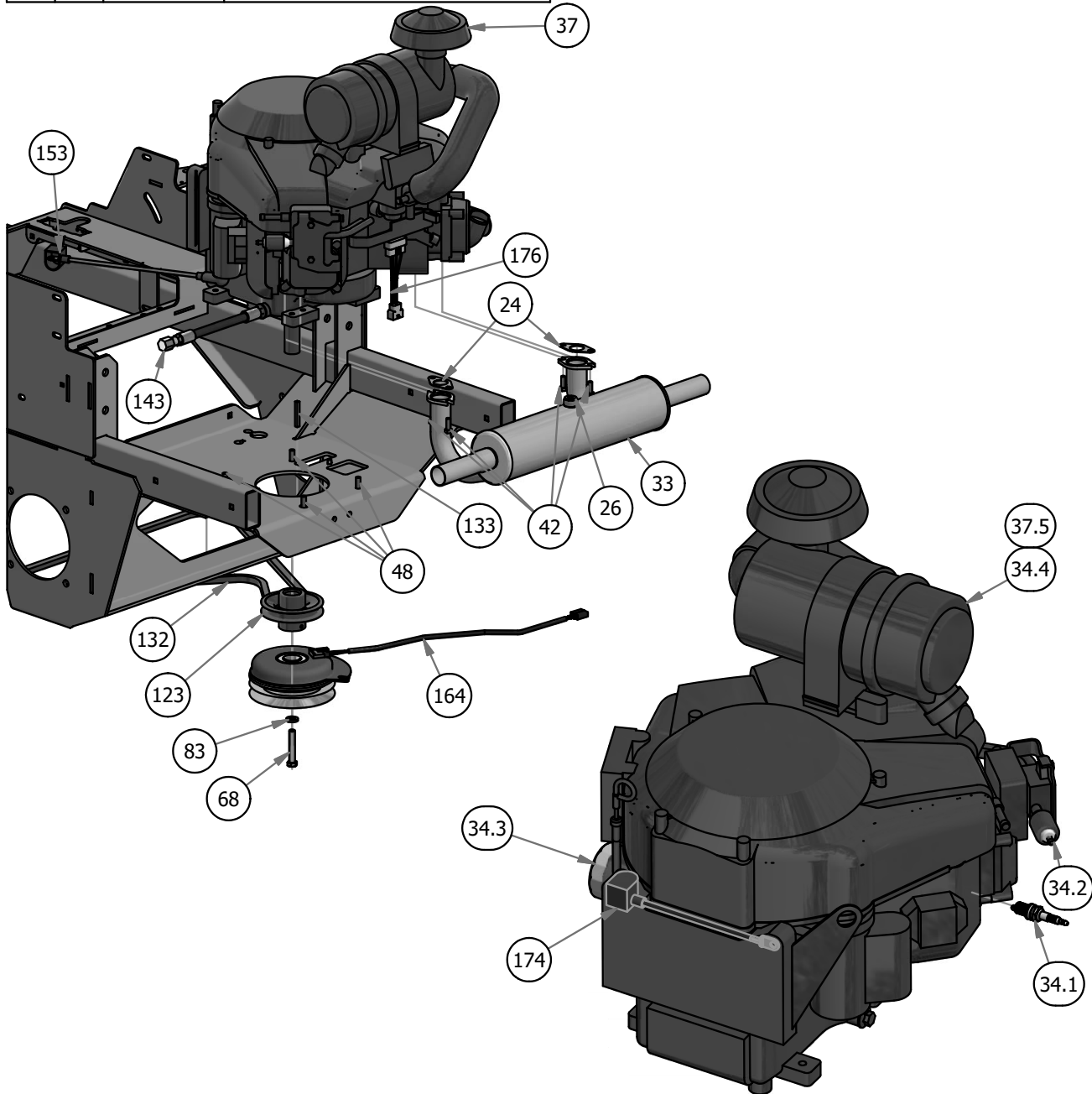



BAD BOY MOWERS

PARTS SECTION: ENGINE - 852cc KAWASAKI FX850

Parts List				Parts List			
ITEM	QTY	PART NUMBER	DESCRIPTION	ITEM	QTY	PART NUMBER	DESCRIPTION
5	4	013-0075-00	M8-1.25 Zinc Nut	82	5	019-8051-00	5/16" Lock Washer
25	1	015-0031-00	Kawasaki FX850 Engine	83	1	019-8053-00	7/16" Lock Washer
25.1	2	015-8001-00	Spark Plug - Kawasaki	123	1	033-5035-00	4 3/4 Motor Pulley
25.2	1	063-6000-00	Universal Inline Fuel Filter	132	1	041-8050-00	2019 Rebel Pump Belt
25.3	1	063-8017-00	Oil Filter	133	1	042-5020-00	1/4 x 2 Square key Stock
25.4	1	063-8019-00	Canister Air Filter- Outer	145	1	051-5407-00	Kawasaki Oil Drain
25.5	1	063-8020-00	Canister Air Filter- Inner	153	1	064-5301-01	14" Red Battery Cable-Base Outlaw
31	1	015-1011-00	2019 Rebel/Rogue Kawasaki 850 Muffler	163	1	070-1000-00	Clutch Assembly
35	2	015-2709-00	Exhaust Gasket	164	1	070-2000-00	Clutch Pigtail
48	4	018-1075-00	3/8 x 1 1/8 bolt	165	1	070-5371-19	2019 Rigid Frame
68	1	018-5300-00	7/16" x 2 1/2" Hex Bolt	174	1	086-0005-00	Starter Cable
69	1	018-5321-00	M8x1.20x20MM Hex head bolt				

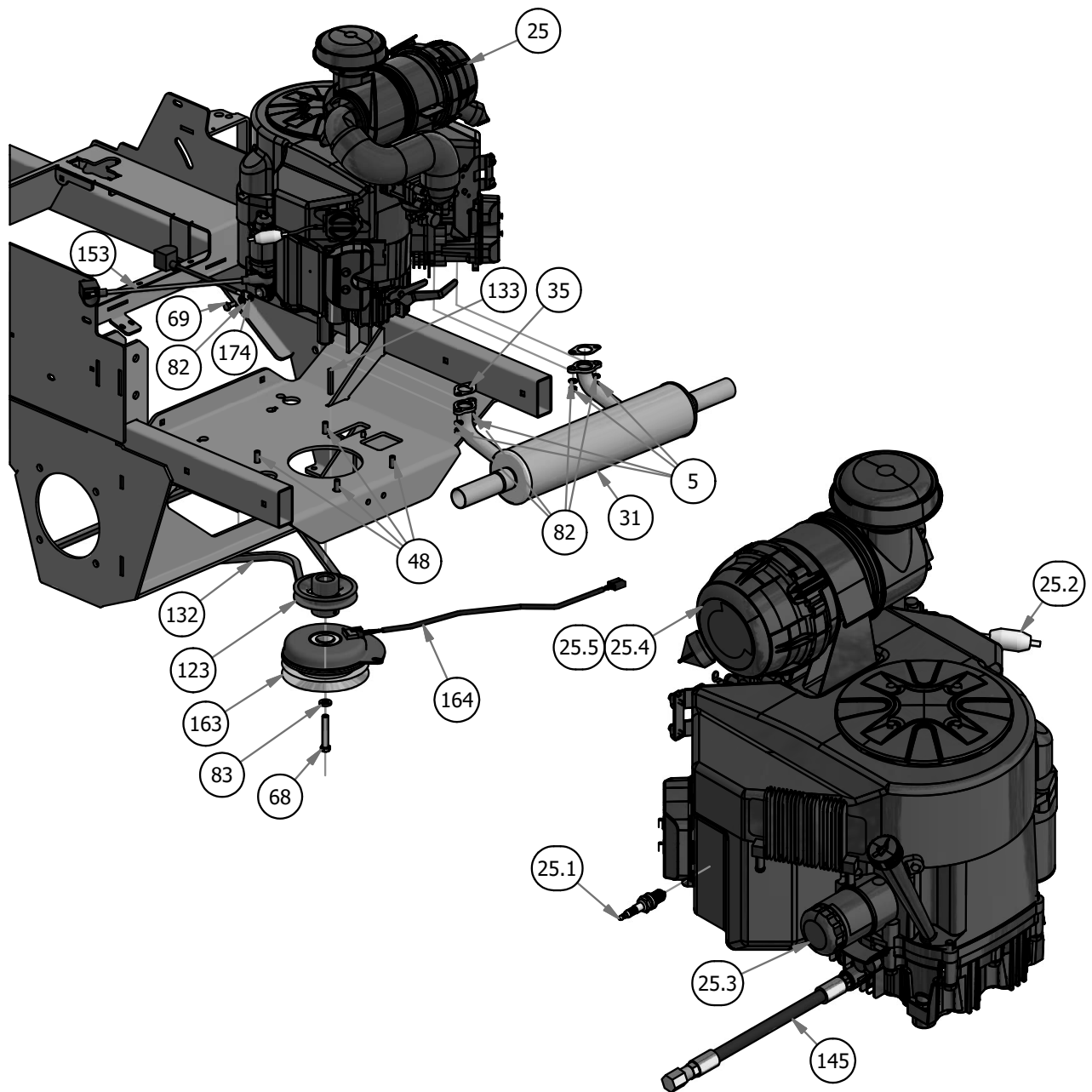



BAD BOY MOWERS

PARTS SECTION: ENGINE - 999cc KAWASAKI FX1000

Parts List				Parts List			
ITEM	QTY	PART NUMBER	DESCRIPTION	ITEM	QTY	PART NUMBER	DESCRIPTION
5	4	013-0075-00	M8-1.25 Zinc Nut	82	4	019-8051-00	5/16" Lock Washer
29	1	015-1010-00	Muffler for Kawasaki FX1000	83	1	019-8053-00	7/16" Lock Washer
30	2	015-1010-01	Exhaust Gasket	123	1	033-5035-00	4 3/4 Motor Pulley
39	1	015-9911-00	Kawasaki FX1000 Engine	132	1	041-8050-00	2019 Rebel Pump Belt
38.1	2	015-8001-00	Spark Plug - Kawasaki	133	1	042-5020-00	1/4 x 2 Square key Stock
38.2	1	063-6000-00	Universal Inline Fuel Filter	145	1	051-5407-00	Kawasaki Oil Drain
38.3	1	063-8017-00	Oil Filter	153	1	064-5301-01	14" Red Battery Cable-Base Outlaw
38.4	1	063-8019-00	Canister Air Filter- Outer	163	1	070-1000-00	Clutch Assembly
38.5	1	063-8020-00	Canister Air Filter- Inner	164	1	070-2000-00	Clutch Pigtail
48	4	018-1075-00	3/8 x 1 1/8 bolt	165	1	070-5371-19	2019 Rigid Frame
68	1	018-5300-00	7/16" x 2 1/2" Hex Bolt	174	1	086-0005-00	Starter Cable

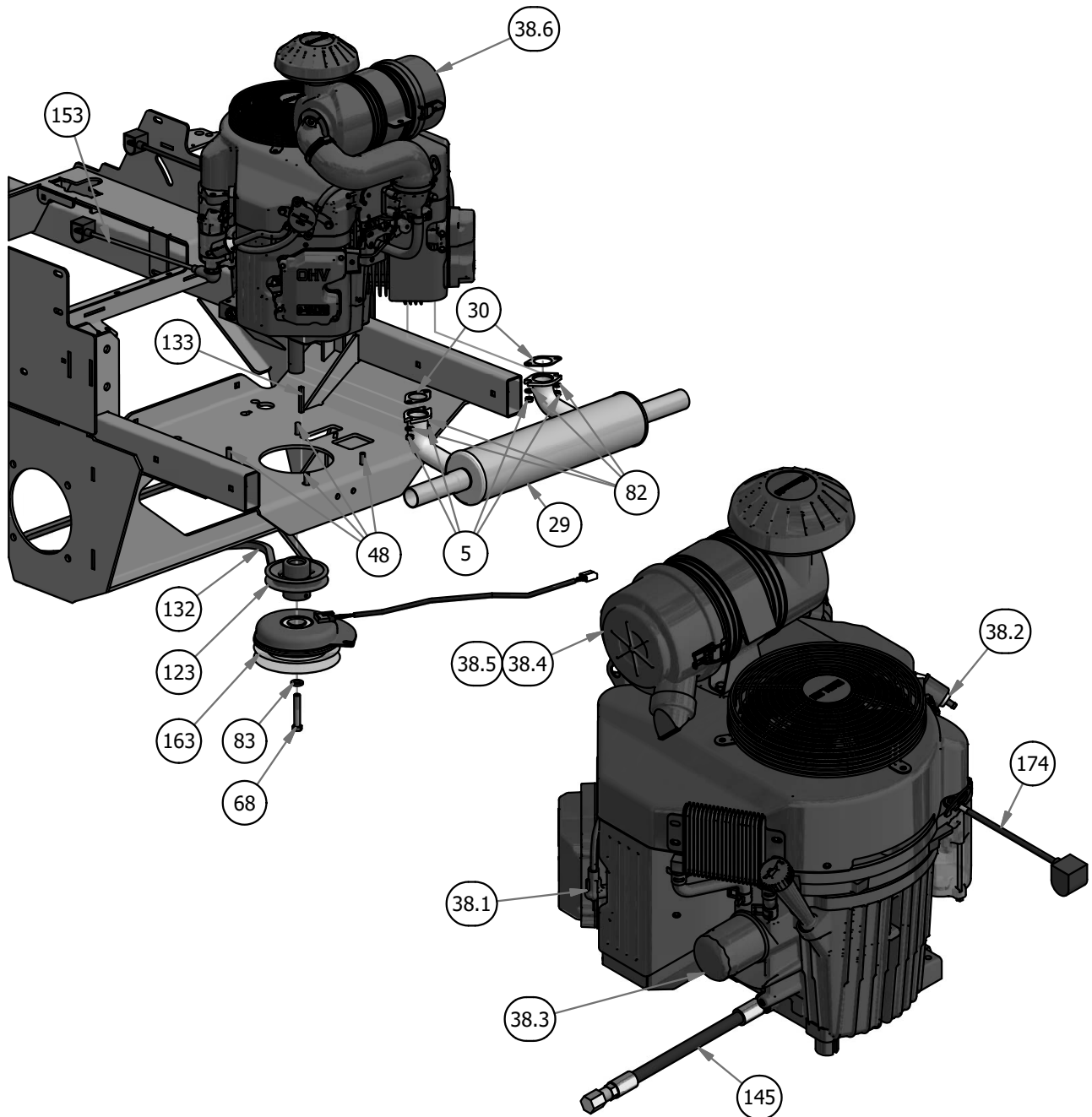



BAD BOY MOWERS

PARTS SECTION: DECALS

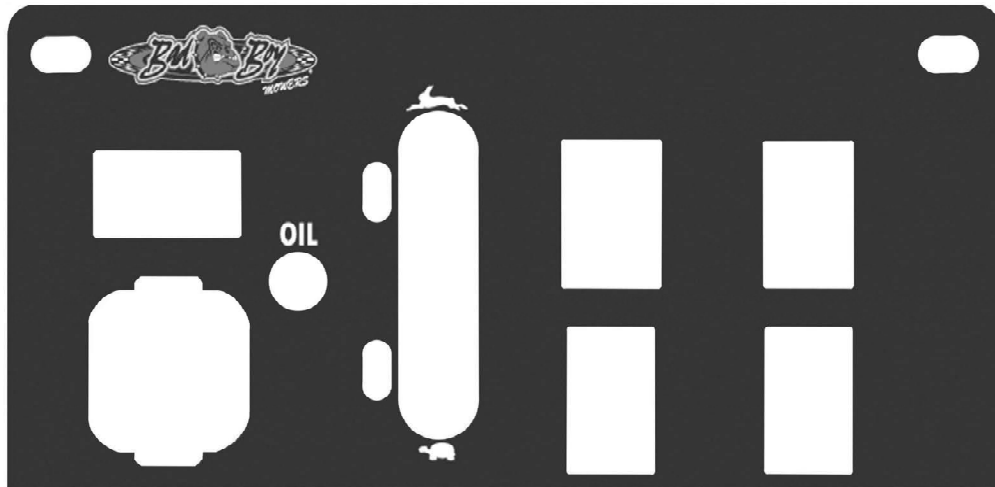

091-4009-00

CONTROL PANEL DECAL



091-4002-00

POWERED BY VANGUARD DECAL

POWERED BY



091-4003-00

POWERED BY KAWASAKI DECAL



091-4004-00

POWERED BY KOHLER DECAL



091-4006-00

824cc BACKPLATE DECAL



091-4007-00

852cc BACKPLATE DECAL



091-4008-00

993cc BACKPLATE DECAL



091-4011-00

747cc BACKPLATE DECAL



091-4023-00

999cc BACKPLATE DECAL



BAD BOY MOWERS

PARTS SECTION: DECALS



091-4010-00
REBEL COOLER COVER DECAL



091-0904-18
54" DECK DECAL



091-0917-18
61" DECK DECAL



091-0918-18
72" DECK DECAL

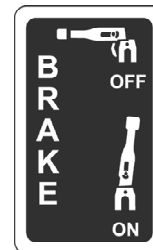

091-1101-18
BRAKE DECAL



091-1114-00
STEERING SPEED CONTROL DECAL



091-8001-00
DECK IMPACT PATENT DECAL

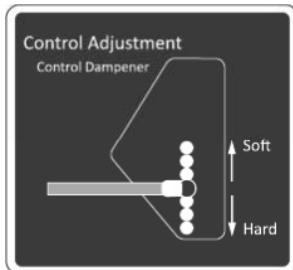

091-4039-00
CONTROL DAMPENER ADJUSTMENT DECAL

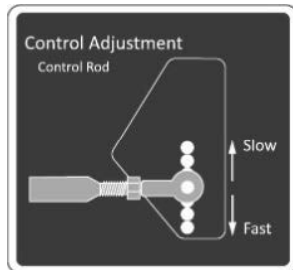

091-4038-00
CONTROL ROD ADJUSTMENT DECAL

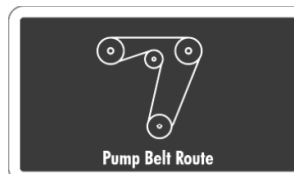

091-4034-00
PUMP BELT ROUTE DECAL

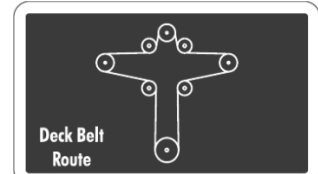

091-4036-00
DECK BELT ROUTE DECAL

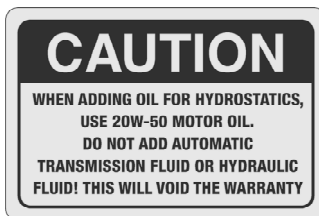

091-1020-00
HYDRAULIC CAUTION DECAL



091-3010-00
DANGER DECAL

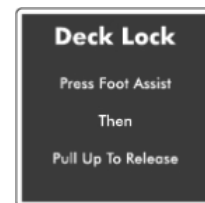

091-4037-00
DECK LOCK DECAL



091-3150-00
WARNING DECAL



BAD BOY MOWERS

2019 LIMITED WARRANTY FOR BAD BOY COMMERCIAL MOWER (REVOLT, REBEL, ROUGE, and RENEGADE)

1. WHAT THIS WARRANTY COVERS, AND FOR HOW LONG:

Bad Boy, Inc. will, at its option, repair or replace, without charge, any part covered by the warranty which is found to be defective in material and/or workmanship for two (2) years * after the date of sale to the original retail purchaser unless the product is used for rental purposes, in which case this warranty is limited to ninety (90) days.

The leading edge of the deck shell will be warranted for the entire lifetime of the machine to the original purchaser against defects in materials and workmanship. Labor required to repair or replace the leading edge of the deck shell will be covered by Bad Boy Inc. for two years and at the unit owner's expense during the balance of the lifetime of the machine.

Belts are warranted for a period of ninety (90) days against materials or workmanship defects.

Seats are warranted for a period of (6) months against material or workmanship defects.

At Bad Boy, Inc.'s request, customer will make the defective part available for inspection by Bad Boy, Inc. and/or return the defective part to Bad Boy, Inc., transportation charges prepaid.

2. WHAT THIS WARRANTY DOES NOT COVER:

- A. This warranty does not cover defects caused by depreciation or damage caused by normal wear, accidents, improper maintenance, improper use or abuse of the product, alterations, or failure to follow the instruction contained in the Owner's Manual for operation and maintenance.
- B. The customer shall pay any charges for making service calls and/or for transporting the mower to and from the place where the inspection and/or warranty work is performed.
Bad Boy Inc will not be responsible for the pickup and delivery of a machine for warranty purposes.
- C. Engines are warranted separately by their respective manufacturer. The available warranties covering this item are furnished with each mower. Bad Boy, Inc does not assume any warranty obligation, liability or modification for this item, which is covered exclusively by the stated warranty of the respective manufacturers.
- D. Tires, blades, deck anti-scalping wheels, and dust covers are considered to be consumable wear items and are therefore not warranted.
- E. Batteries are warranted for six months (free replacement) from the retail purchase date against materials or workmanship defects. The battery warranty must be obtained through the battery manufacturer.
- F. Normal maintenance services such as oil change, cleaning, lubrication, adjustment.
- G. Replacement of services, items, such as oil, lubricants, spark plugs, belts, rubber hoses or other items subject to normal service replacement.

3. HOW TO OBTAIN SERVICE UNDER THIS WARRANTY:

- A. Warranty service can be arranged by contacting the dealer where you purchased the mower. Proof of the date of purchase may be required to verify warranty coverage. Warranty repairs must be completed by an authorized Bad Boy center.
- B. Warranty claims will not be reviewed or paid unless the warranty registration is received by Bad Boy, Inc. within 30 days of the retail purchase date.
- C. Warranty claims requiring parts returned will be settled upon return of parts to Bad Boy for inspection.
- D. All warranty issues must be handled through an authorized service center or dealership.

4. WARRANTY LIMITATION:

- A. **THERE IS NO OTHER EXPRESS WARRANTY. ANY WARRANTY THAT MAY BE IMPLIED FROM THIS PURCHASE INCLUDING MERCHANTABILITY AND FITNESS FOR A PARTICULAR PURPOSE IS HEREBY LIMITED TO THE DURATION OF THIS WARRANTY AND TO THE EXTENT PERMITTED BY LAW ANY AND ALL IMPLIED WARRANTIES ARE EXCLUDED.** Some states do not allow limitations on how long an implied warranty lasts, so the above limitations may not apply to you.

- B. **BAD BOY, INC. WILL NOT BE LIABLE FOR ANY INCIDENTAL, CONSEQUENTIAL, OR SPECIAL DAMAGES AND/OR EXPENSES IN CONNECTION WITH THE PURCHASE OR USE OF THE MOWER.** Some states do not allow the exclusion or limitation of incidental or consequential damages, so the above limitation(s) or exclusion(s) may not apply to you.

- C. Only the warranty expressed in this limited warranty shall apply and no dealer, distributor, or individual is authorized to amend, modify, or extend this warranty in any way. Accordingly, additional statements such as dealer advertising or presentations, whether oral or written, do not constitute warranties by Bad boy, Inc., and should not be relied on.
- D. This warranty extends only to turf equipment operated under normal conditions and properly serviced and maintained. The warranty expressly does not cover (i) any defects, damage or deterioration due to normal use, wear and tear, or exposure; (ii) normal maintenance services such as oil change, cleaning, lubrication, adjustment; (iii) replacement of services, items, such as oil, lubricants, spark plugs, belts, rubber hoses or other items subject to normal service replacement; (iv) damage or defects arising out of or relating to misuse, neglect, alteration, negligence or accident; (v) repair or replacement arising from operation of or use of the turf equipment which is not in accordance with operating instructions as specified in the operator's manual or other operational instructions provided by Bad Boy Inc.; (vi) repair or replacement arising as a result of any operation from turf equipment that has been altered or modified so as to, indetermination of Bad Boy, Inc., adversely affect the operation, performance or durability of the equipment or that has altered, modified or affected the turf equipment so as to change the intended use of the product; (vii) repair or replacement necessitated by use of parts, accessories or supplies, including gasoline, oil or lubricants, incompatible with the turf equipment or other than as recommended in the operator's manual or other operational instructions provided by Bad Boy, Inc.; (viii) repairs or replacements resulting from parts or accessories which have adversely affected the operation, performance or durability of the turf equipment; or (ix) damage or defects due to or arising out of repair of turf equipment by person or persons other than an authorized Bad Boy, Inc., service dealer or the installation of parts other than genuine Bad Boy, Inc., recommended parts.
As a condition to this warranty, customer shall have read the operator's manual and ensured the mower has been registered within 30 days of purchase.
- E. This warranty gives you specific legal rights, and you may also have other rights, which vary from state to state.



BAD BOY, INC.

102 INDUSTRIAL DRIVE

BATESVILLE, AR 72501

WWW.BADBOYMOWERS.COM

Technical Support:.....techsupport@badboymowers.com

Warranty:warranty@badboymowers.com

Parts:partsdept@badboymowers.com

WARRANTY REGISTRATION

**Ensure selling dealership has registered mower within
30 days of purchase to validate warranty.**

Please record your serial number, date of purchase and dealership information
for your records.

Serial # _____

Date of Purchase _____

Dealer Information _____



**BAD BOY
MOWERS**

www.badboymowers.com

Bad Boy, Inc.

102 Industrial Drive

Batesville, Arkansas 72501