

**DELUXE
WALL MOUNT
PULL-UP BAR &
BAG HANGER**

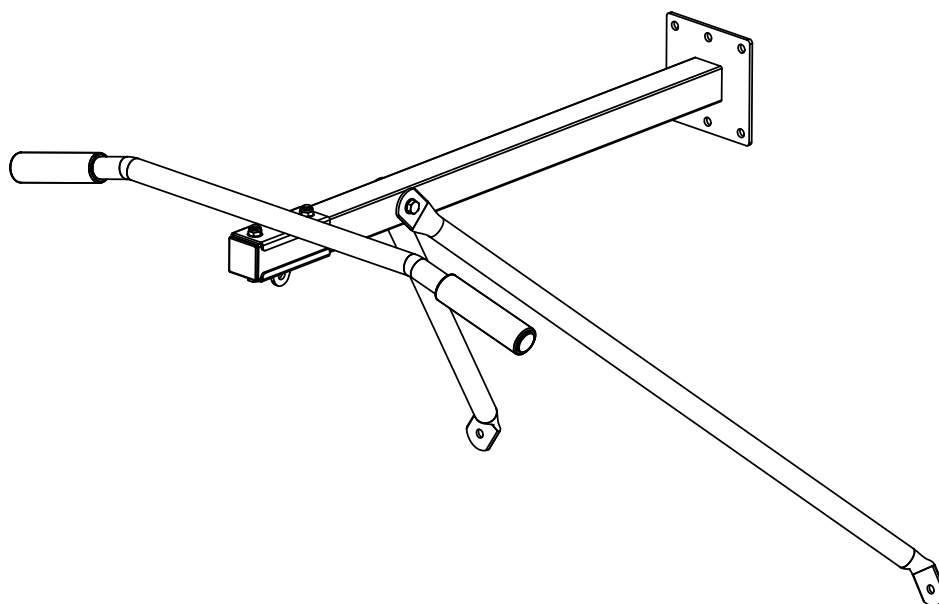

Owner's Manual

PARTS LIST & ASSEMBLY

- Hardware Package**

No.	Description	Q'ty
1	M10 x 75 bolt	3
2	M10 nut	3
3	∅ 10 washer	6

- Attached to the Frame**

4	50 tube plug	1
5	∅ 32 tube plug	2
6	150 handle	2

- Packed in the Box**

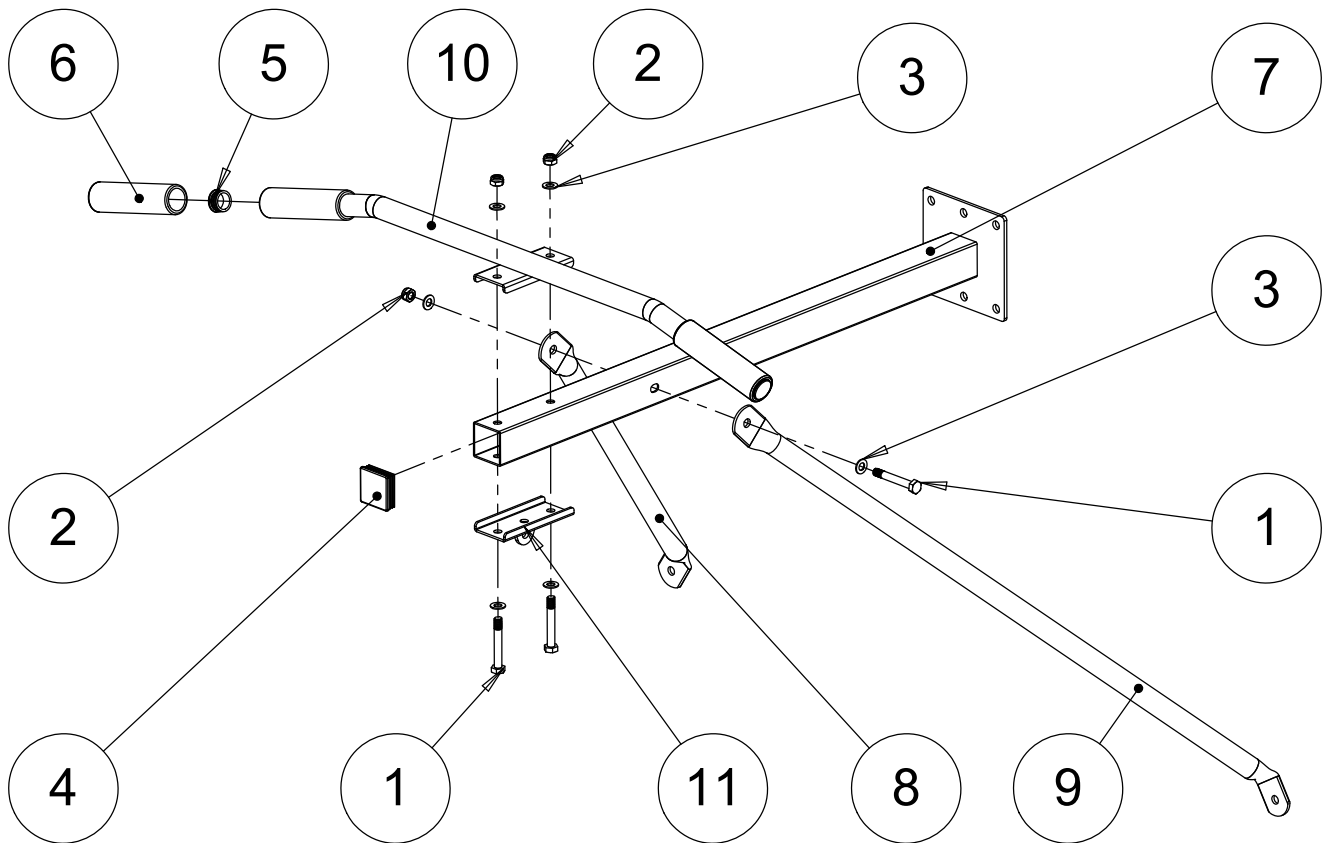
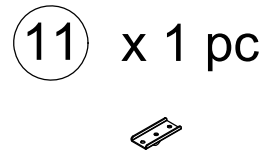
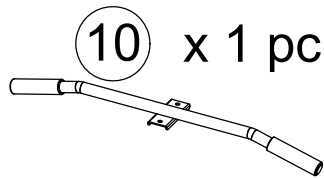
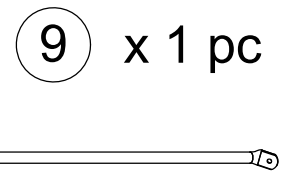
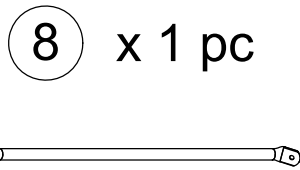
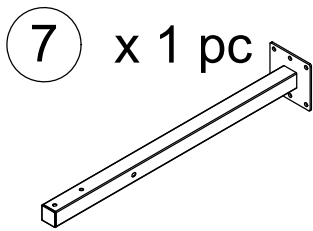

INSTRUCTION

1. Assemble the TITLE Deluxe Wallmount Pull-Up Bar & Bag Hanger as illustrated with the hardware included. Make sure all bolts, nuts, end caps and connections are tightly secured.
2. Determine the ideal height for hanging the unit. The ideal height to hang on a wall is with the top bar between 7' (84") and 8' (96") high. If you're going to use the unit to attach a punching bag or double end bag also, you'll want to hang it with top bar at least 8' high to accommodate the punching bag hanging chain and/or double end bag top cord lengths.
3. If securing to a masonry wall, you'll need 6 hex head lag screws (4-3/4" x 3/8"), 6, 3/8" flat washers and 6 metal lag expansion shields (2-1/2" x 3/8"). Use a level to make sure you have the wall mount placed evenly. Mark the mounting holes on the wall with a pencil or marker and then drill pilot holes into the wall before securing the unit with the noted hardware.
4. If securing to wood stud wall, you'll need 6 hex head lag screws (4-3/4" x 3/8") and 6, 3/8" flat washers. Secure two brace boards onto the wall first to attach the top brace and bottom brace onto. Next, use a level to make sure you have the wall mount placed evenly. Mark the mounting holes on the wall with a pencil or marker and then drill pilot holes into the brace boards before securing the unit with the noted hardware. The unit is designed for the two outside top brace mounting holes and bottom middle brace holes to secure into 16" OC wood studs.
5. Make sure all the mounts and connections are secured tightly and the hanger is stable and secure before every use.

WARNING:

- Make sure to use at least two people to assemble and hang the unit.
- Check the unit before using every time to assure it is stable and in excellent condition, with no loose parts or connections.
- Always consult a physician before beginning any workout and exercise program.
- It is recommended to you always wear hand wraps and well-padded bag gloves when hitting the heavy bag and double end bag.
- It is recommended that you always use a spotter when using the pull-up and chin-up bar.
- Always keep the area around the hanger clear of all objects before every use.
- Maximum Weight Limits: Pull-Up Bar 250 Lbs, Bag Hanger 150 Lbs.