

**DELUXE
WALL MOUNT
HEAVY BAG
HANGER 2.0**

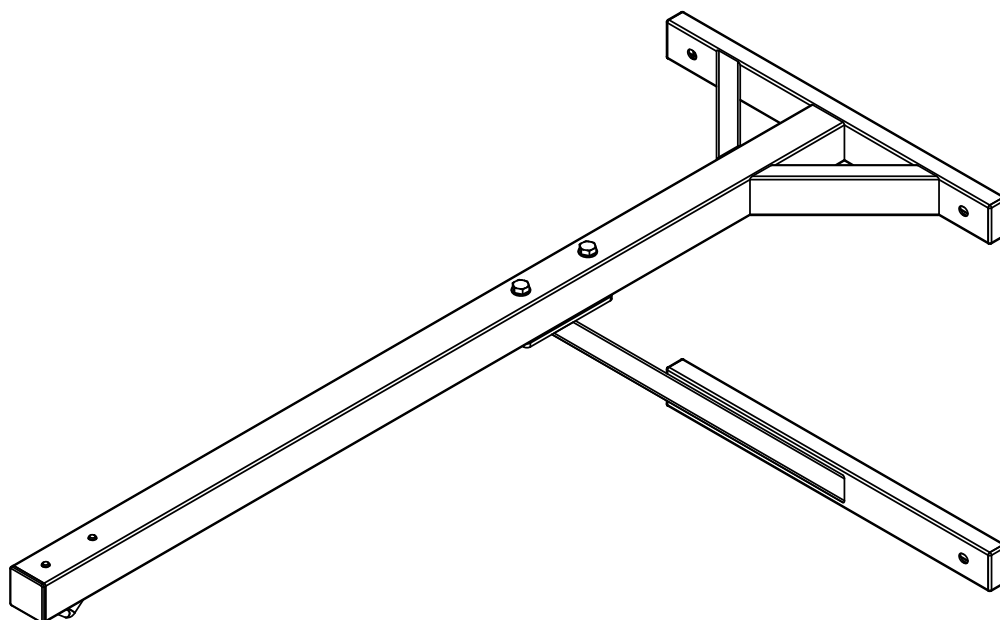

Owner's Manual

WMHBH2

PARTS LIST & ASSEMBLY

- Hardware Package

No.	Description	Q'ty
1	M10 x 70 bolt	2
2	M10 nut	2
3	∅ 10 washer	4

- Attached to the Frame

4	50 tube plug	1
5	2550 tube plug	4

- Packed in the Box

⑥ x 1 pc

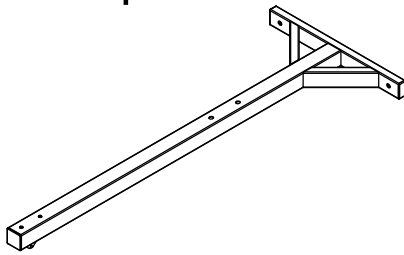

⑦ x 1pc

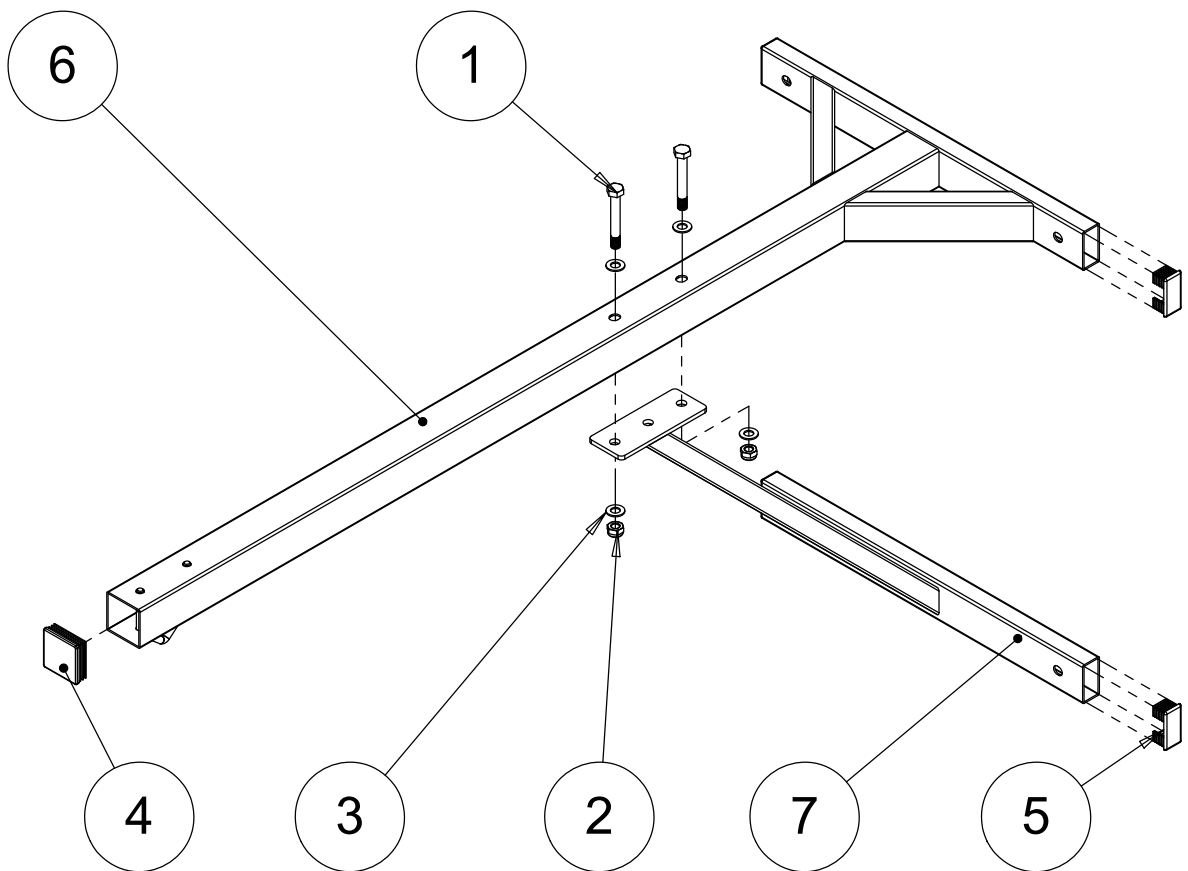
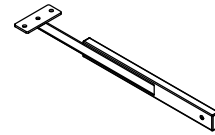

INSTRUCTION

1. Assemble the TITLE Deluxe Wallmount Heavy Bag Hanger as illustrated with the hardware included. Make sure all the bolts, nuts, plastic end caps and connections are tightly secured.
2. Determine the ideal height for hanging the unit. The ideal height to hang on a wall is with the top bar at least 8' (96") high. This allows approximately 18"-24" for the heavy bag hanging chain or straps and attachment S-hook or spring hook. You want to punch the heavy bag in the top third to middle of the bag when hanging.
3. If securing to a masonry wall, you'll need 4 hex head lag screws (4-3/4" x 3/8"), 4, 3/8" flat washers and 4 metal lag expansion shields (2-1/2" x 3/8"). Use a level to make sure you have the wall mount placed evenly. Mark the mounting holes on the wall with a pencil or marker and then drill pilot holes into the wall before securing the unit with the noted hardware.
4. If securing to wood stud wall, you'll need 4 hex head lag screws (4-3/4" x 3/8") and 4, 3/8" flat washers. Secure two brace boards onto the wall first to attach the top brace and bottom brace onto. Next, use a level to make sure you have the wall mount placed evenly. Mark the mounting holes on the wall with a pencil or marker and then drill pilot holes into the brace boards before securing the unit with the noted hardware. The unit is designed for the top brace mounting holes and bottom brace mounting holes to secure into 16" OC wood studs.
5. Make sure all the mounts and connections are secured tightly and the hanger is stable and secure before every use.

WARNING:

- Make sure to use at least two people to assemble and hang the unit.
- Check the unit before using every time to assure it is stable and in excellent condition, with no loose parts or connections.
- Always consult a physician before beginning any workout and exercise program.
- It is recommended that you always wear hand wraps and well-padded bag gloves when hitting the heavy bag and double end bag.
- Always keep the area around the hanger clear of all objects before every use.
- Maximum Heavy Bag Weight Limit: 200 Lbs.