



Duramax 6.6L 2017-2023 EGR Delete Kit & Downpipe

General Installation Guide

EGR Delete

Step 1: Disconnect all batteries and drain engine coolant.

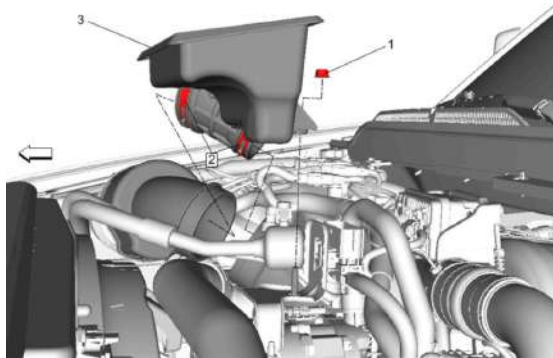

Step 2: Remove air cleaner outlet resonator.

Step 3: Remove serpentine belt from AC Compressor and alternator pulley. Remove alternator and unbolt AC Compressor and move it off to the side.

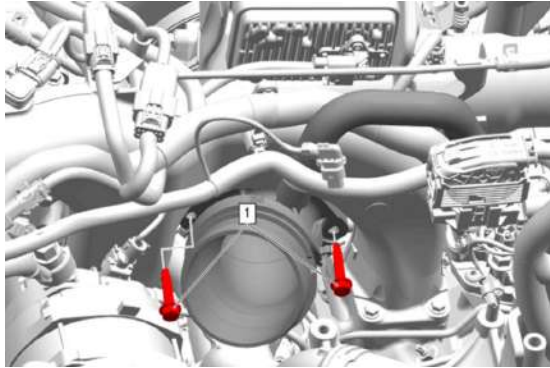

Step 4: Remove turbocharger air inlet adapter and move it out of the way carefully as these are not serviceable.

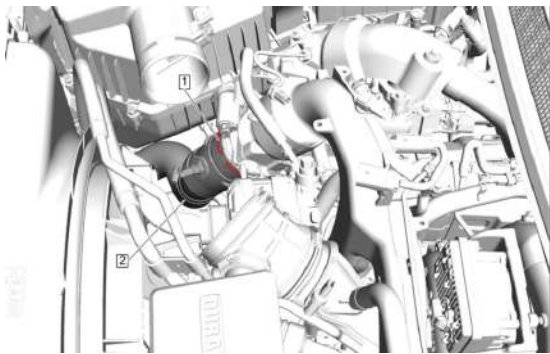

Step 5: Disconnect charge air cooler outlet to upper intake manifold.

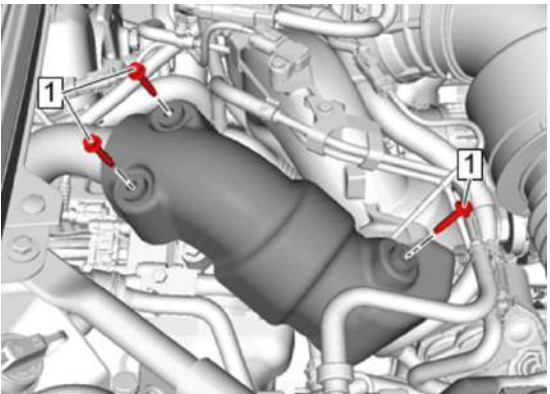

Step 6: Remove EGR Valve pipe heat shield

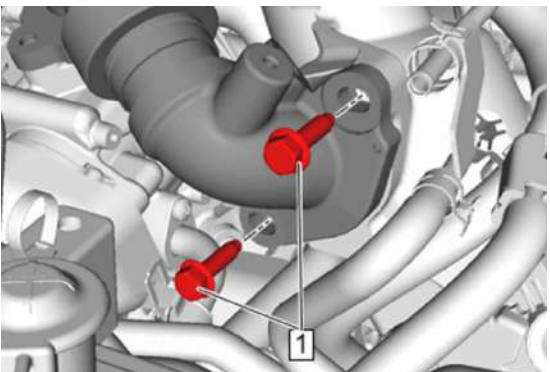

Step 7: Remove EGR Pipe bolts.

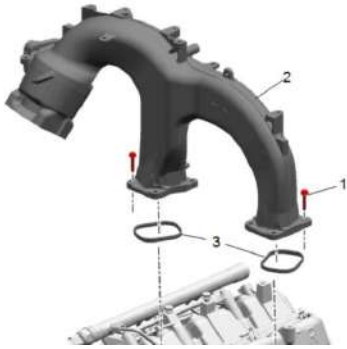

intake manifold to the lower intake manifolds and remove the upper intake manifold. Install the provided block off plate with a new gasket.

Step 8: Unplug all electrical connectors, unclip wiring harness, unbolt coolant line support bracket and disconnect the line to move it out of the way. Remove the 8 bolts that hold the upper

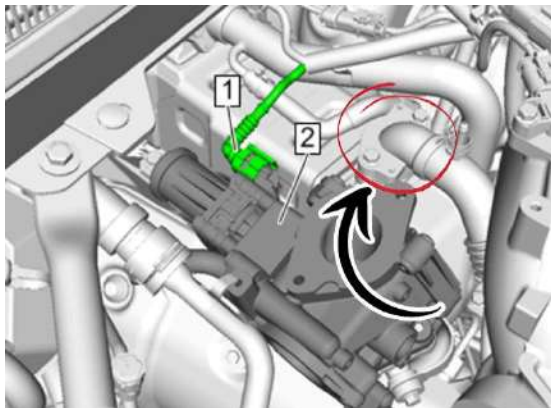

Step 9: Disconnect EGR connector and remove the coolant pipe that is attached to the cooler.

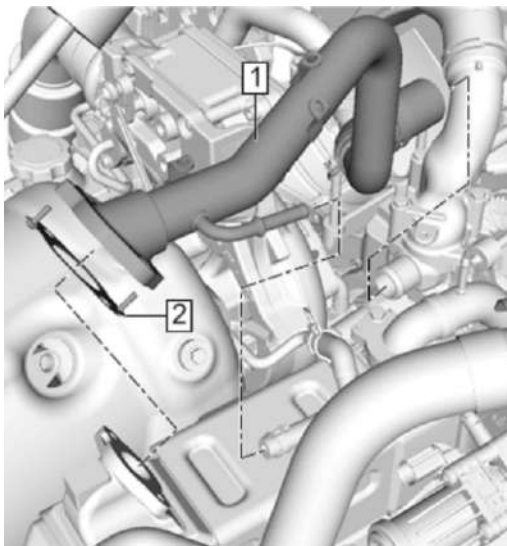

Step 10: Remove EGR Cooler coolant feed pipe. Remove rubber hose off the end for reuse.

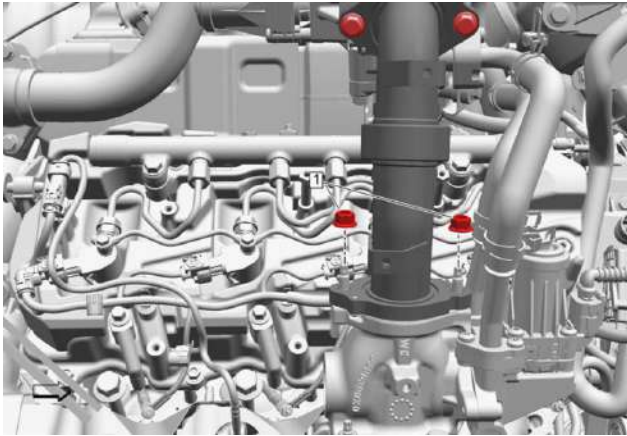

Step 11: Remove EGR pipe.

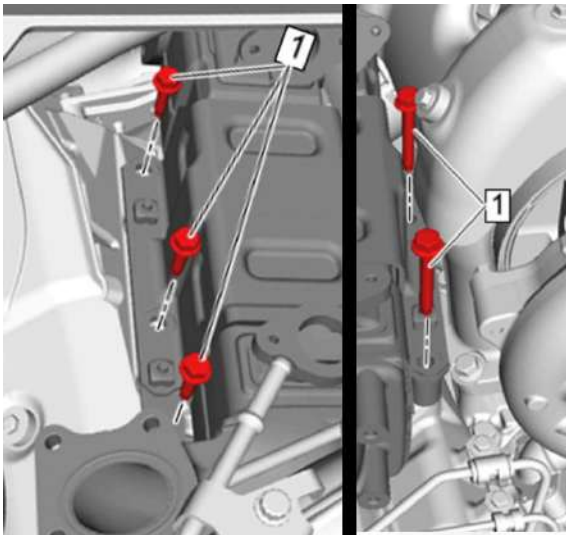

Step 12: Unbolt EGR Cooler and remove assembly.

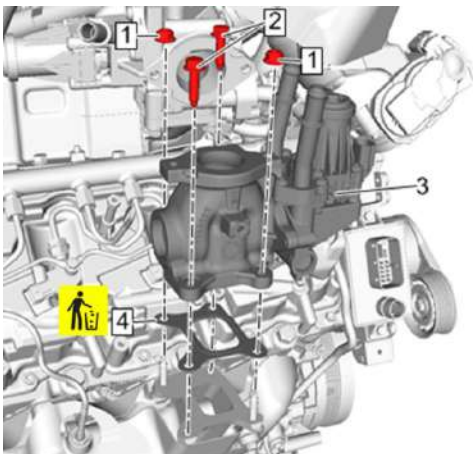

Step 13: Remove EGR Valve, install supplied block off plate and gasket.



Step 14: Install provided coolant block off plug with O-ring in this location.

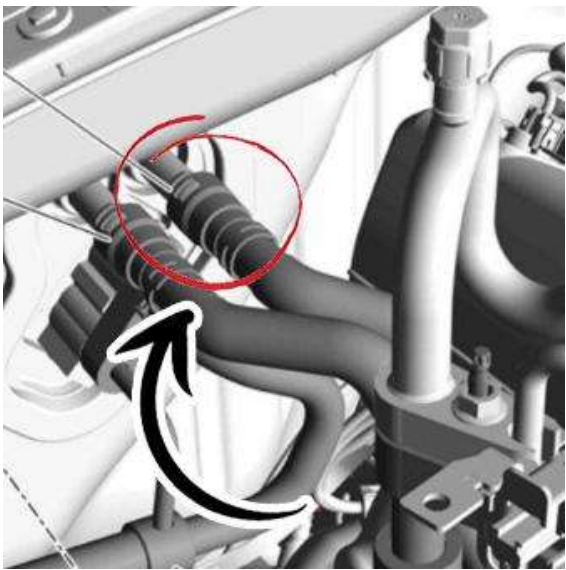

Step 15: Remove the circled heater core hose that is closest to the engine. Remove the hose from the fitting and reuse factory fitting, attach it to the provided coolant hose.



Do not complete this step if you are also installing a downpipe. Complete after downpipe install.

Step 16: Install provided coolant hose from step 15 from the fire wall to the pictured line. You reuse the hose from step 10.

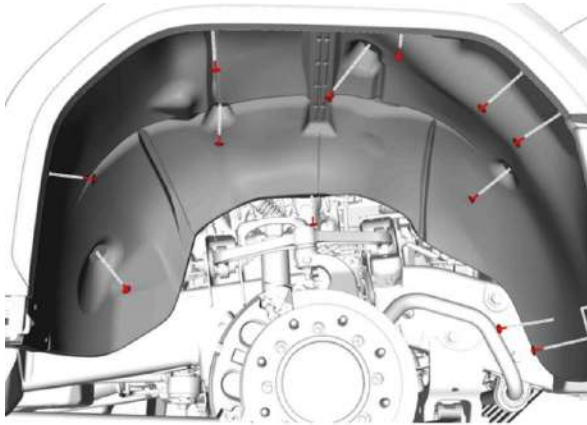

Step 17: Remove passenger side fender liner.

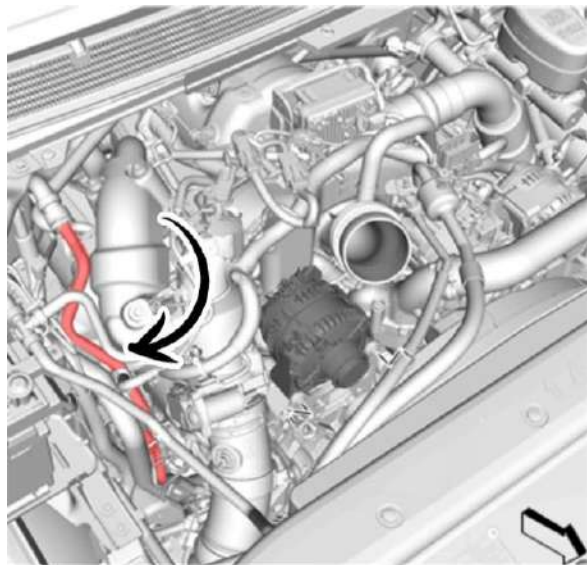

Step 18: Unbolt and remove coolant hose assembly

Install provided barb plug



Step 19: Install the larger supplied hose that has a preinstalled barb. On the upper side use the provided quick connect fitting, connect the bottom side to the fitting shown in the photo, with supplied hose clamp.

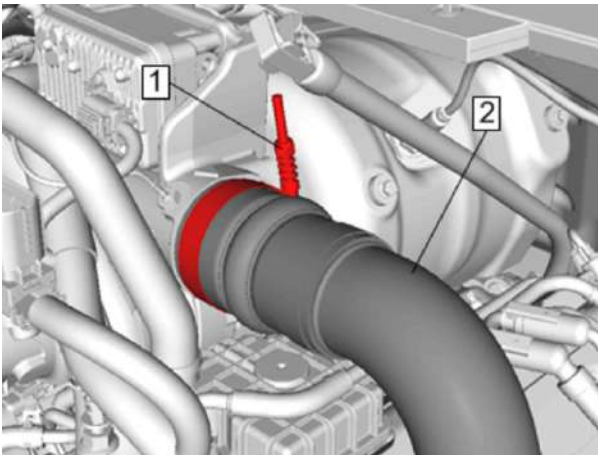

Note: At this point we recommend taking the exhaust wrap and soaking it in a bucket of water. Wearing gloves while handling the wrap is recommended.

Step 17: Disconnect charge air pipe from turbo compressor housing.

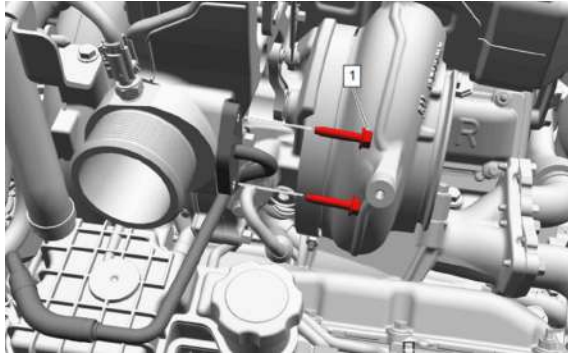

Step 18: Unbolt PCV hose from the turbocharger and reposition it out of the way.

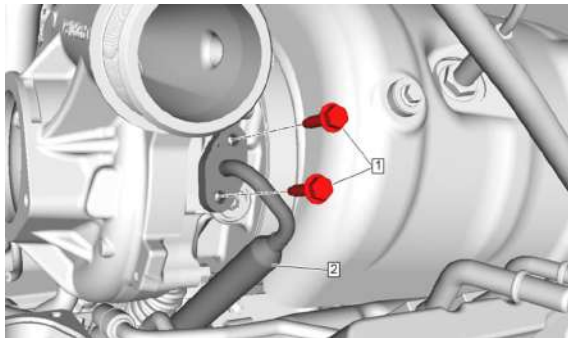

Step 19: Unbolt oil feed pipe from turbocharger

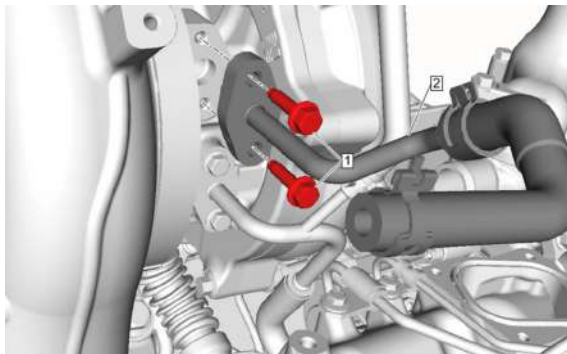

Step 20: Unbolt coolant return line from the turbo charger.

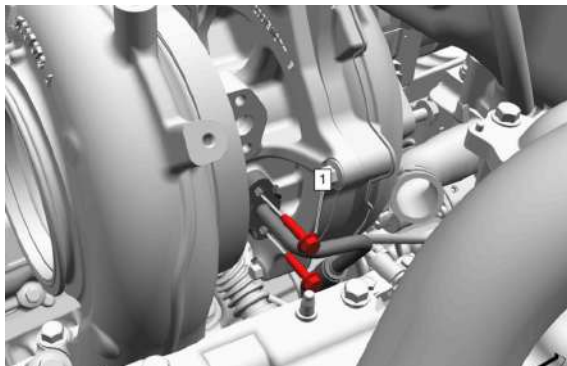

Step 21: Unbolt coolant feed line from the turbo charger.

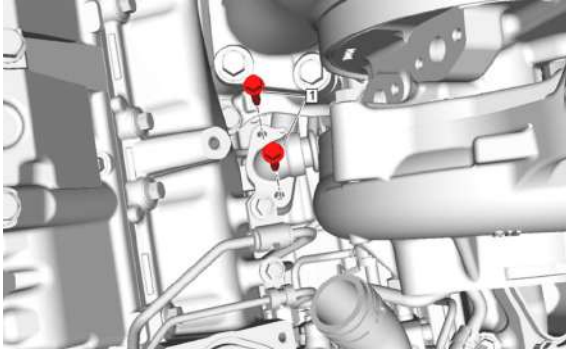

Step 22: Unbolt oil drain pipe.

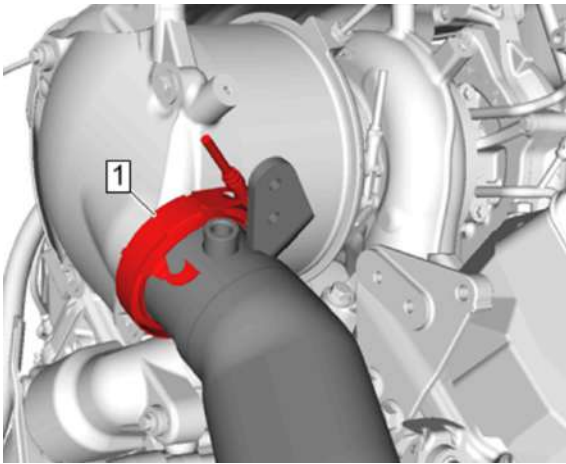

Step 23: Undo v-band clamp that attaches the turbo to the catalytic converter. Undo 4 hold down bolts for the turbo and remove the turbo.

Step 24: Loosen the remaining lower v-band clamp on the catalytic converter. Disconnect sensor and remove the catalytic converter.

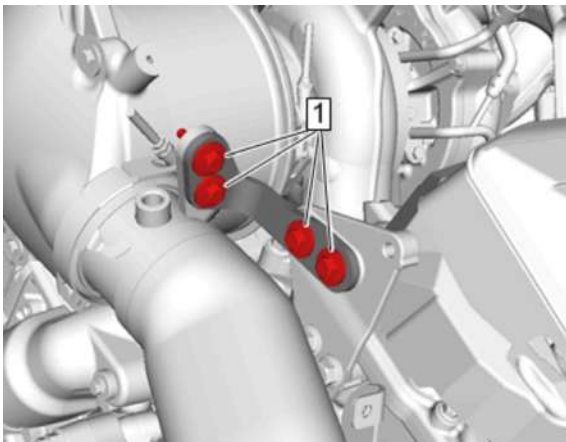

Step 25: Remove the downpipe bracket bolts and discard the bracket.

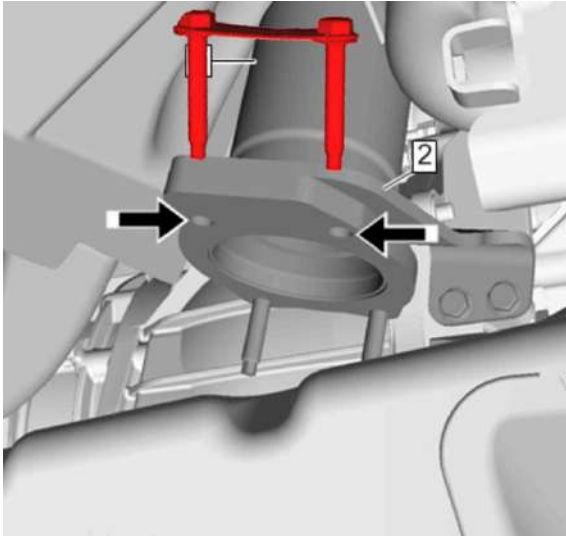

Step 26: Remove 4 downpipe to front pipe mounting nuts & studs and remove factory downpipe from the vehicle.

Step 27: Take the header wrap that you had soaking in a bucket of water and wrap the downpipe. Use the supplied clamps on both ends of the wrap. Again, wearing gloves while handling exhaust wrap is recommended.

Step 28: Weave the downpipe in from the top of the vehicle. Reinstall turbo, feed & return lines with supplied gaskets. Bolt the new downpipe to the turbo. Do not tighten the v-band clamp at this time. Tighten this v-band clamp once your full aftermarket exhaust is installed (If installing an aftermarket exhaust). If you are not installing an aftermarket exhaust you can tighten the v-band clamp.



Step 29: Install supplied rubber coolant cap.

Step 30: Reinstall upper intake manifold and associated assemblies.



Step 31: Replace factory coolant hose with provided coolant hose that has a preinstalled barb as pictured.

Step 32: Reinstall turbo inlet adapter.