



F930 Electrical Communication Connection Box - VersaCom Box

Installation Guide

Read all instructions before installing!!!

General:

Gill's electrical communication connection boxes (VersaCom Boxes) can be installed in track surfacing, asphalt or concrete. If the F910 is installed in asphalt or concrete, it can be purchased with black Vultrack, a resilient and non-porous material that is bonded to the recessed box cover. But, if the box is installed in a track surface, the track contractor is able to fill the lid with the same material being used on the track. This is possible because the angle on the edge of the cover is used as a retainer, so the material can be poured and setup on top of the cover.

Drainage is key when installing the open bottom communication box. The box should be placed on a well-drained substrate. If it is away from the well-drained substrate a solid concrete bottom with a drainage pipe should be included to prevent standing water.

The divider plate provides sections to separate electrical utilities from communications wiring. This plate can be removed to furnish an open mounting area if preferred.

Placement:

Set a concrete brick in a stiff patty of mortar under each corner of the box. The height of the box is 14". The top of the bricks should be 15" below finished grade for natural grass and ½" artificial turf fields. If the field is artificial infill turf, add the depth of the infill material to the 15" from the top of the bricks. For example, if 1½" of infill is being installed, the top of brick should be placed at 16½" below finished grade. Position the box on the corner bricks and then level the box with the adjuster bolts located in each corner to even the rim of the box to the finished grade of the grass.

F90010 Risers

If the F990 riser is being installed, add another 14" of depth from the top of the brick. To install the riser, remove the adjuster bolts from the corners and stack the F900 or F910 on top of the riser. The holes in the bottom gussets of the F900 or F910 and the top gussets of the riser should be aligned. Place the adjuster bolts through the aligned holes and tighten down with the provided nut. Place the assembled unit on the corner bricks as described above and level the rim using the adjuster bolts in the bottom of the F990 riser.

Concrete:

Place the mortar around the outside and inside corners of the box for support. Make sure to cover the bottom inside corners with mortar to secure the adjustor bolts in their final position. This will physically lock the box into place. The entire box does not need to be surround by concrete. However, it is recommended that a small amount of concrete be poured around the outside bottom of the box to help maintain its position and strength throughout its use at the facility.

If the divider plate is to be eliminated, remove it at this time, but do reinstall the bolts to seal the outside of the box. Then backfill around the outside of the box with the same materials used in that particular cross section of the field, i.e. gravel, stone, asphalt, concrete or elastic layer.

Electrical Conduit and Wiring

Through the open bottom of the box the wire conduits are exposed. Receptacle boxes can be installed directly to the inner panel of the aluminum with self-drilling screws. If a solid concrete bottom and drain are to be installed, be careful to slope the concrete bottom toward the outlet for positive drainage.

Important Note:

Gill communication boxes are not watertight, so proper drainage is required. UL approved electrical and communication junction boxes are to be used with watertight connections.

F910 (with out track surface) Track surface can be poured onto the lid of this Versacom Box or cut and bonded, depending on the surface type.

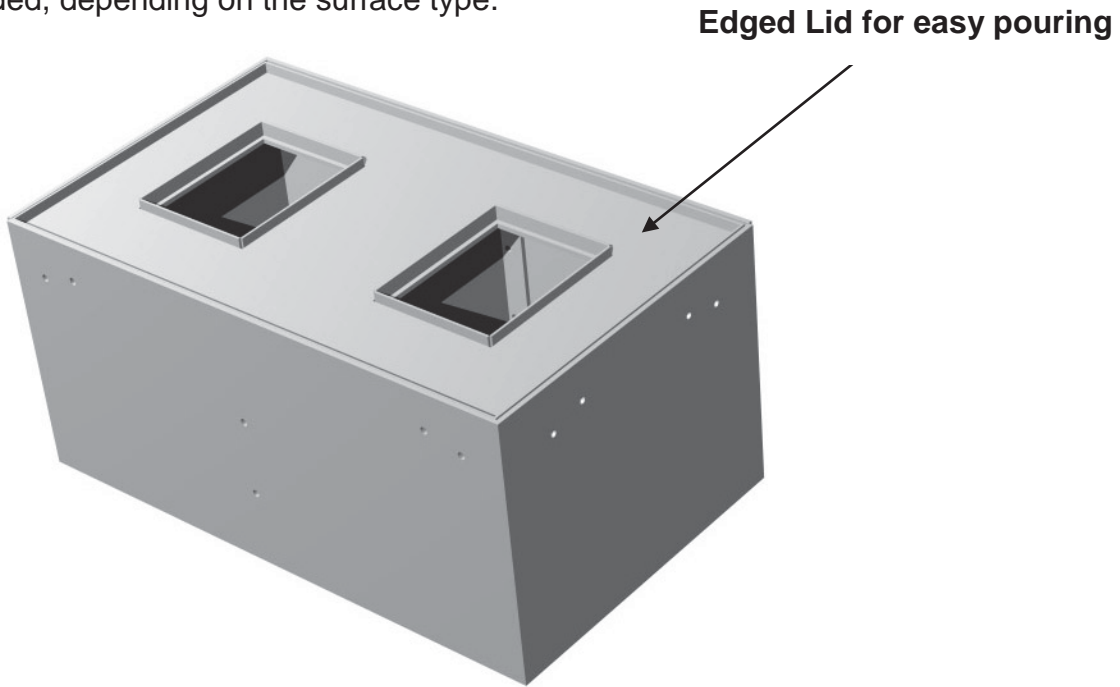

Note: Also can put surface onto the hand hole covers.

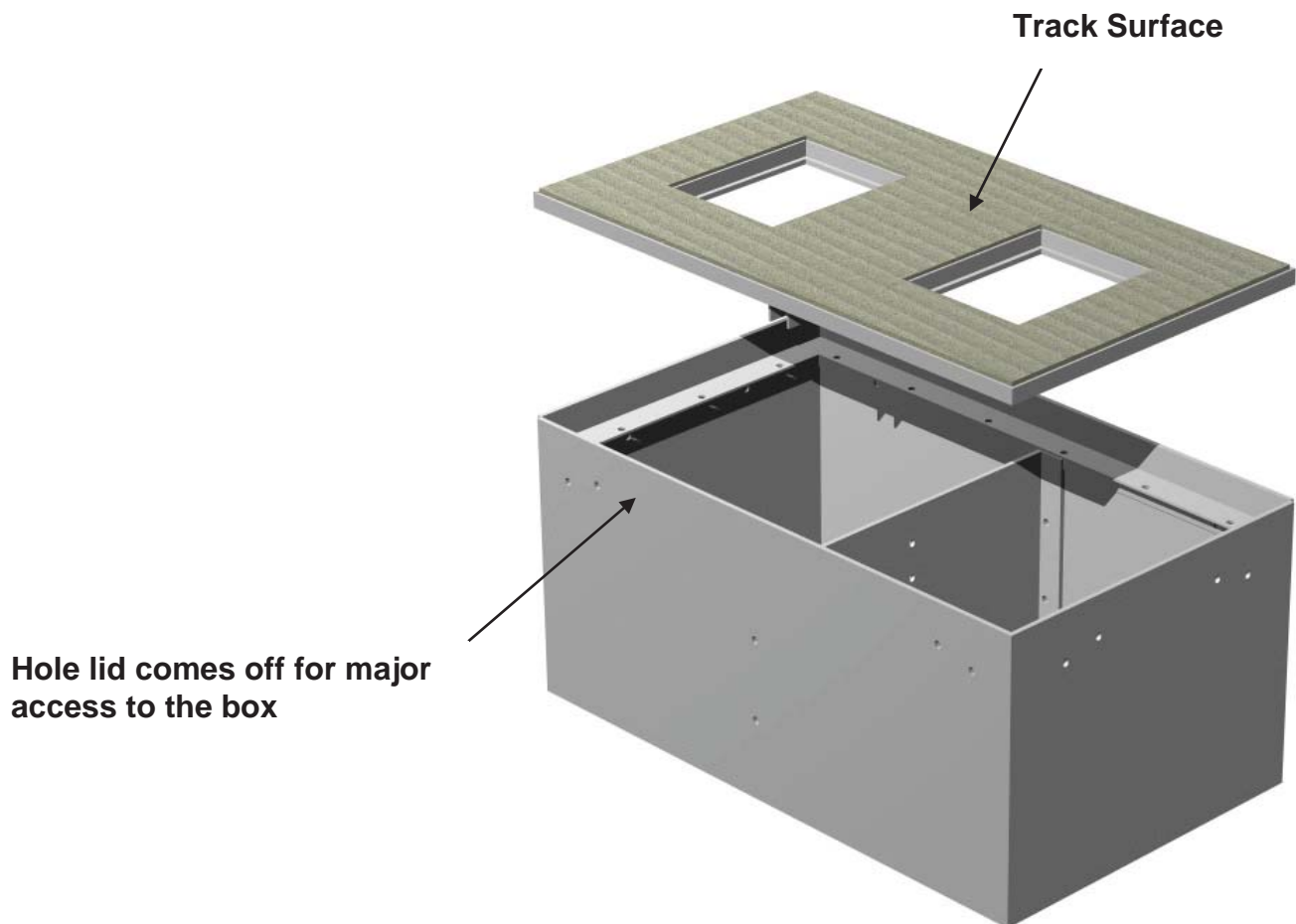



www.gillathletics.com
800-637-3090

F930 - VersaCom Half Box - Synthetic Version

SPECIFICATIONS

The VersaCom Half Box provides a junction for electricity and cable hookups. This box can be put in virtually any location around performance areas of varying surfaces. The open bottom of the VersaCom Box provides adequate drainage and conduit entry, while the hand holes in the cover allow easy access. The main box structure is made of $\frac{1}{4}$ " thick folded aluminum. The lid is constructed out of $\frac{1}{8}$ " aluminum, reinforced by angle and 1" square tubing for maximum durability. Welded lid support angles are compatible with all style lids. Synthetic track surface is installed in the lid by the contractor to match the surrounding surface.

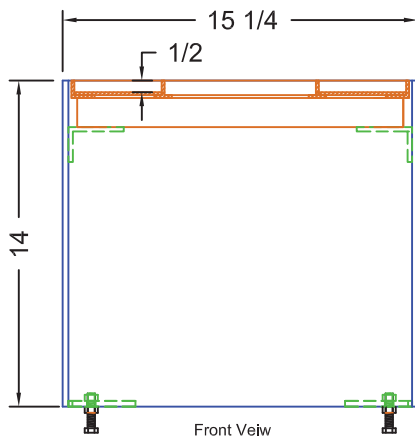

Front View

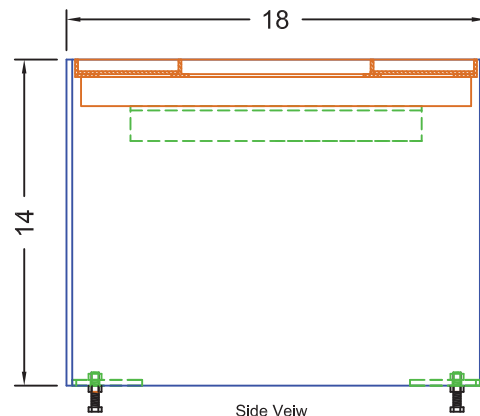

Side View

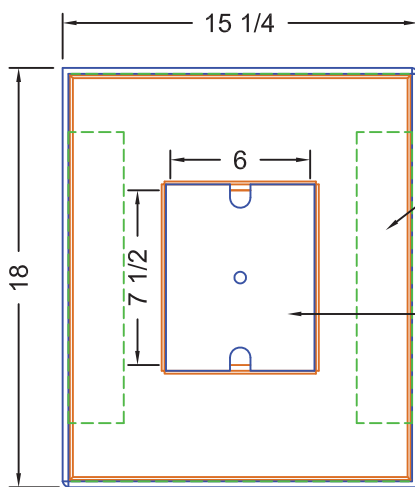

Top View

Welded Lid Support Angles

Shown with Notched Cover in place.

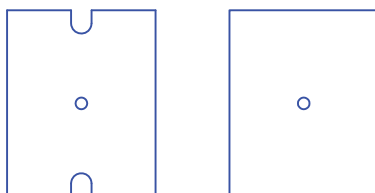

Each lid comes with one set of captive covers. Each set consists of one notched cover for use with cables entering the box and one solid cover for use when the box is not in use.

 **WARNING:** Cancer and Reproductive Harm –
For more information go to www.p65warnings.ca.gov