

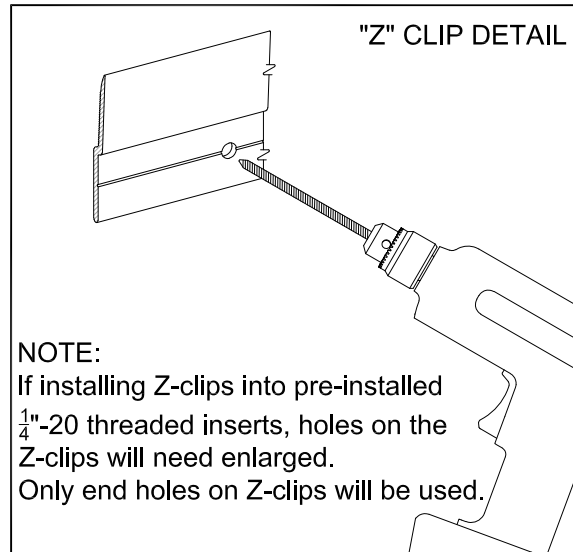

www.gillathletics.com  
800-637-3090

**GENERAL GUIDELINES**

- NEVER install wall pads more than 4" above the finished ground! If directed to install wall pads higher than 4" above the floor, STOP WORKING IMMEDIATELY and contact your local Porter representative. The recommended dimension for outdoor wall pads is 3" to account for the size of a softball.
- Check installation/architectural drawings specific to this project to determine location of wall pads.
- Panels must be inspected and measured before installation. Lay out all pads and mark Z-clip locations.
- To minimize wrinkles in fabric of installed panels, wall must be either perfectly plumb, or slightly convex (bowed out) over the area to be covered. If found to be concave (bowed in), install sufficient shims at midsection of panels to provide plumb or convex wall profile.
- Center Z-clips are needed on pads over 6' tall.
- Vinyl wraps over the top along the back of the pad to create a water barrier. Keep pad in the proper orientation when installing.

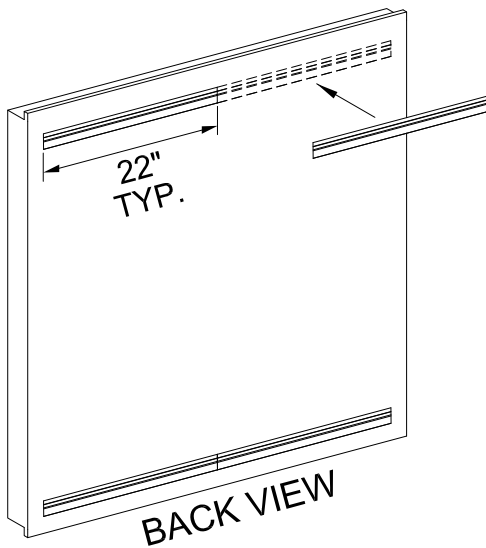

CHAIN LINK FENCE HDWE  
CUT VINYL TO EXPOSE 1/4"-20 THREADED INSERTS



POKE A FEW SMALL HOLES  
IN THE BOTTOM OF EACH  
PAD TO ALLOW FOR  
PROPER DRAINAGE

