

BEST *BF* FITNESS
EQUIPMENT

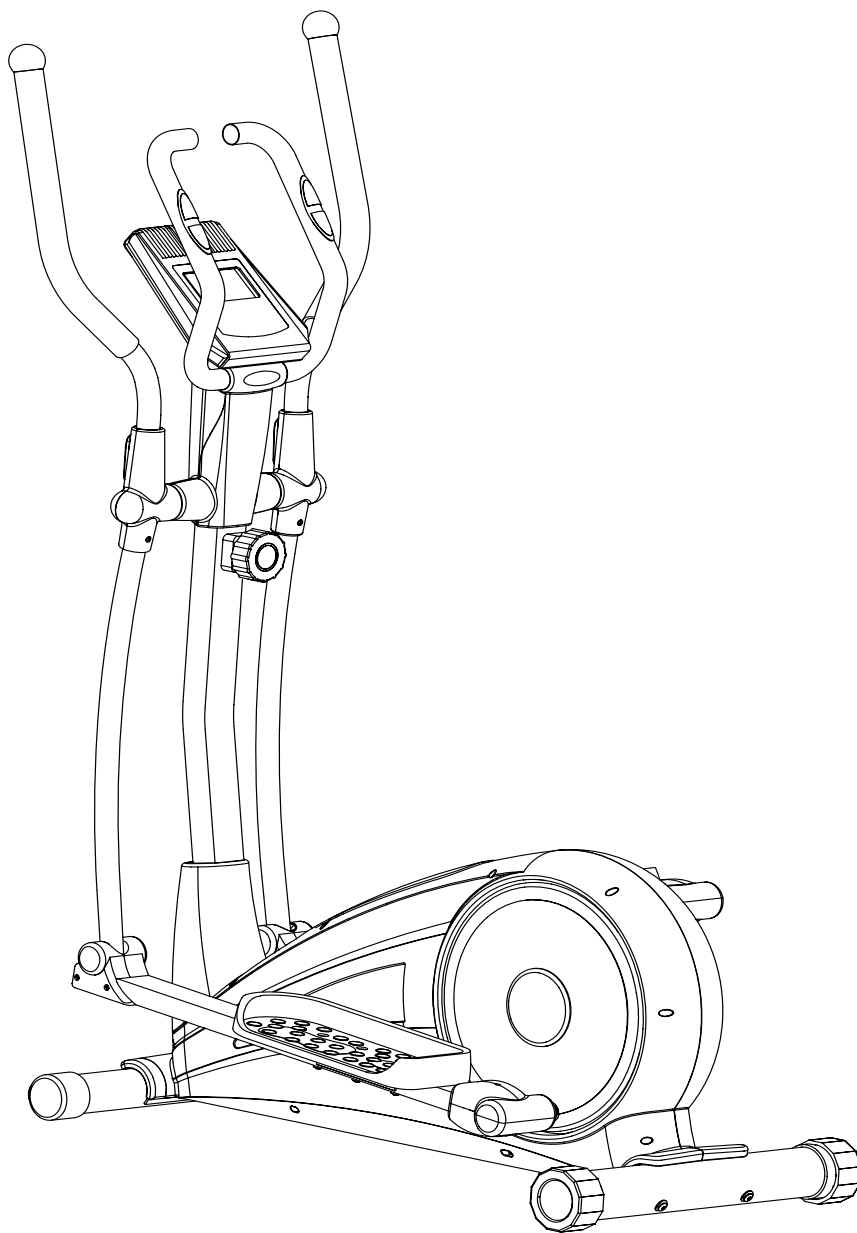

OWNER'S MANUAL BFCT1R

TABLE OF CONTENTS

I.	BEFORE YOU BEGIN.....	3
II.	IMPORTANT SAFETY INSTRUCTIONS.....	4
III.	FEATURES.....	5
IV.	DIMENSIONS.....	6
V.	ASSEMBLY INSTRUCTIONS.....	7 – 21
VI.	SETTING UP YOUR BFCT1R.....	22 – 23
VII.	CONSOLE FEATURES.....	24
VIII.	CONSOLE DISPLAY FEATURES.....	25
IX.	CONSOLE OPERATION.....	26 – 31
X.	EXERCISE TIPS AND GUIDELINES.....	32 – 33
XI.	TROUBLESHOOTING.....	34
XII.	SERVICING THE BFCT1R.....	35
XIII.	HARDWARE.....	36 – 38
XIV.	HARDWARE LIST.....	39 – 41
XV.	EXPLODED VIEW DIAGRAM.....	42 – 43



www.BestFitness.com

BEFORE YOU BEGIN

Thank you for purchasing the Best Fitness Cross Trainer BFCT1R.
To maximize your use of the equipment please study this Owner's Manual thoroughly.

Unpacking the Equipment

The BFCT1R is carefully tested and inspected before shipment. We have shipped the unit in several pieces that require assembly. Ask for assistance during the assembly process.

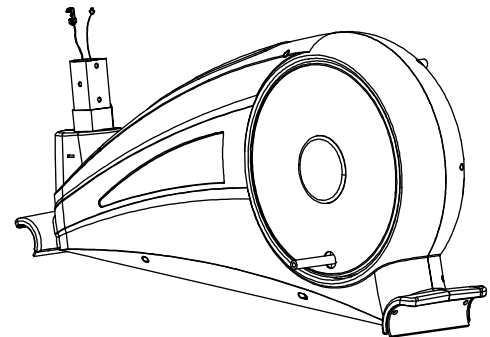
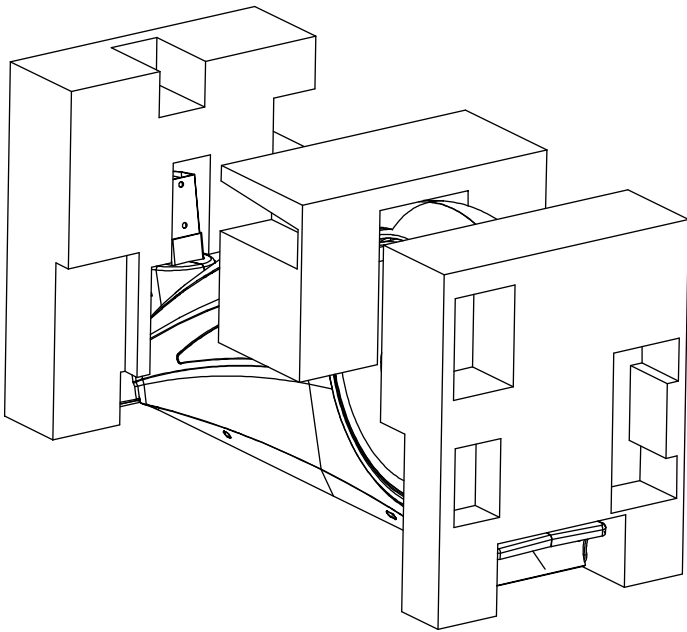

Best Fitness Equipment continually seeks ways to improve the performance, specifications and product manuals in order to ensure that only superior products are released from our factories. Please take the time to carefully read through this manual thoroughly. Instructions contained in this document are not intended to cover all details or variations possible with Best Fitness Equipment, or to cover every contingency that may be met in conjunction with installation, operation, maintenance or troubleshooting of the equipment. Even though we have prepared this manual with extreme care, neither the publisher nor the author can accept responsibility for any errors in, or omission from, the information given. Should additional information be required, or should situations arise that are not covered by this manual, the matter should be directed to your local Best Fitness Equipment representative, or the Service Department at Best Fitness Equipment in Forest Park, Illinois.

Any Questions?
Call (800) 556-3113

IMPORTANT SAFETY INSTRUCTIONS

Before beginning any fitness program, you should obtain a complete physical examination from your physician.

Il est conseillé de subir un examen médical complet avant d'entreprendre tout programme d'exercice. Si vous avez des étourdissements ou des faiblesses, arrêtez les exercices immédiatement.

Antes de comenzar cualquier programa de ejercicios, deberías tener un examen físico con su doctor.

WHEN USING EXERCISE EQUIPMENT, YOU SHOULD ALWAYS TAKE BASIC PRECAUTIONS, INCLUDING THE FOLLOWING:

- Read all instructions before using the BFCT1R. These instructions are written to ensure your safety and to protect the unit.
- Do not allow children on or near the equipment.
- Use the equipment only for its intended purpose as described in this guide. Do not use accessory attachments that are not recommended by the manufacturer. Such attachments might cause injuries.
- Wear proper exercise clothing and shoes for your workout, no loose clothing.
- Use care when getting on or off the unit.
- Do not overexert yourself or work to exhaustion.
- If you feel any pain or abnormal symptoms, stop your workout immediately and consult your physician.
- Never operate the unit when it has been dropped or damaged. Return the equipment to a service center for examination and repair.
- Never drop or insert objects into any opening in the equipment.
- Always check the unit before each use. Make sure that all fasteners are secure and in good working condition.
- Do not use the equipment outdoors or near water.

PERSONAL SAFETY DURING ASSEMBLY

- It is strongly recommended that a qualified dealer assemble the equipment. Assistance is required.
- Before beginning assembly, please take the time to read the instructions thoroughly.
- Read each step in the assembly instructions and follow the steps in sequence. Do not skip ahead. If you skip ahead, you may learn later that you have to disassemble components and that you may have damaged the equipment.
- Assemble and operate the BFCT1R on a solid, level surface. Locate the unit a few feet from the walls or furniture to provide easy access.

The BFCT1R is designed for your enjoyment. By following these precautions and using common sense, you will have many safe and pleasurable hours of healthful exercise with your Best Fitness BFCT1R.

After assembly, you should check all functions to ensure correct operation. If you experience problems, first recheck the assembly instructions to locate any possible errors made during assembly. If you are unable to correct the problem, call the dealer from whom you purchased the machine or call 1-800-556-3113 for the dealer nearest you.

FEATURES

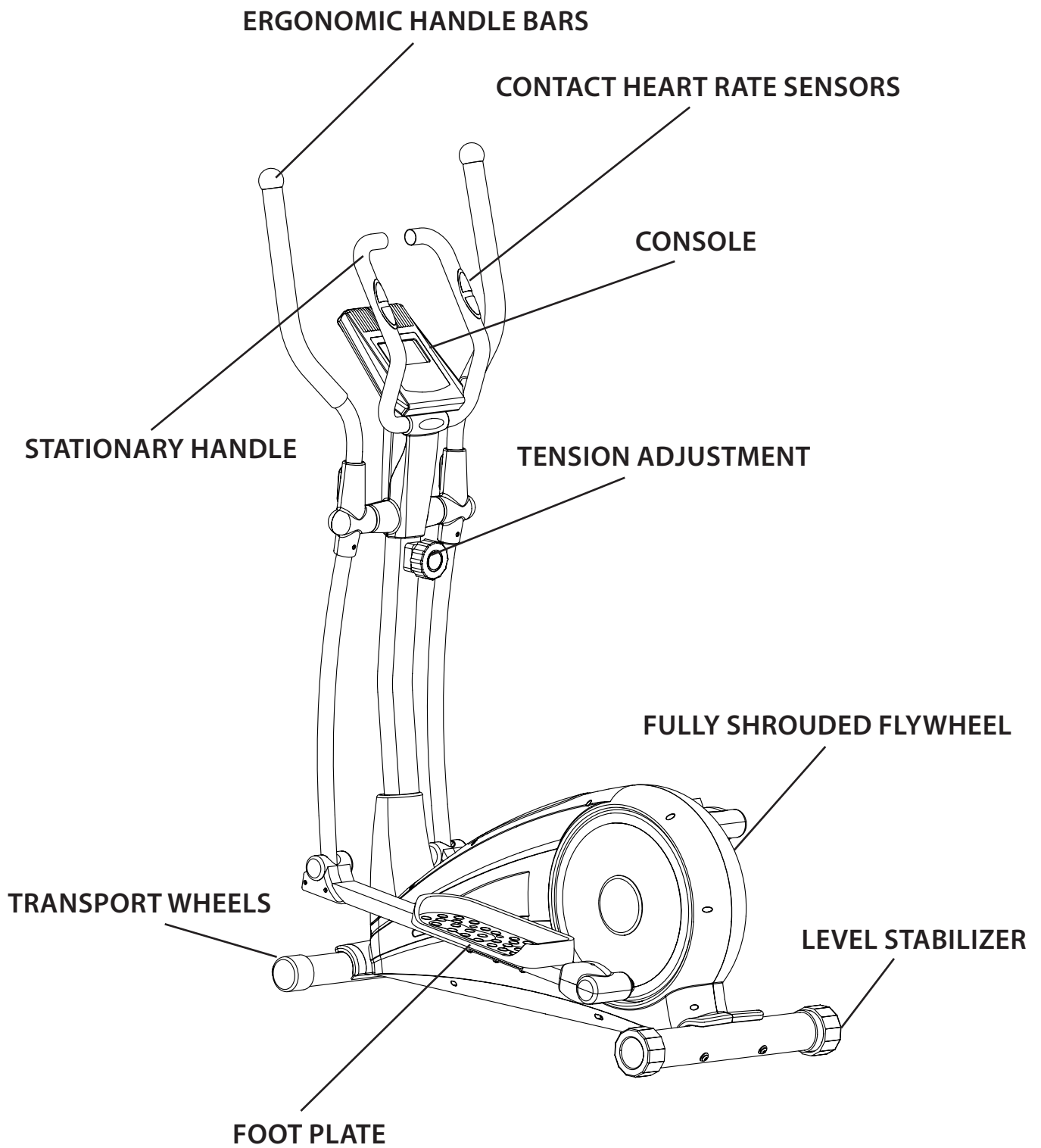

DIMENSIONS

The room layout diagram below will help you decide the best placement for your BFCT1R. The dimensions of the BFCT1R are: Width 1' 9" X Length 4' 3".

The usage space is: Width 3' X Length 6' (The usage space is the overall space needed for operation).

The usage space needed for the BFCT1R could be more, depending on the user.

Suggested Usage Space

Minimum Usage Space

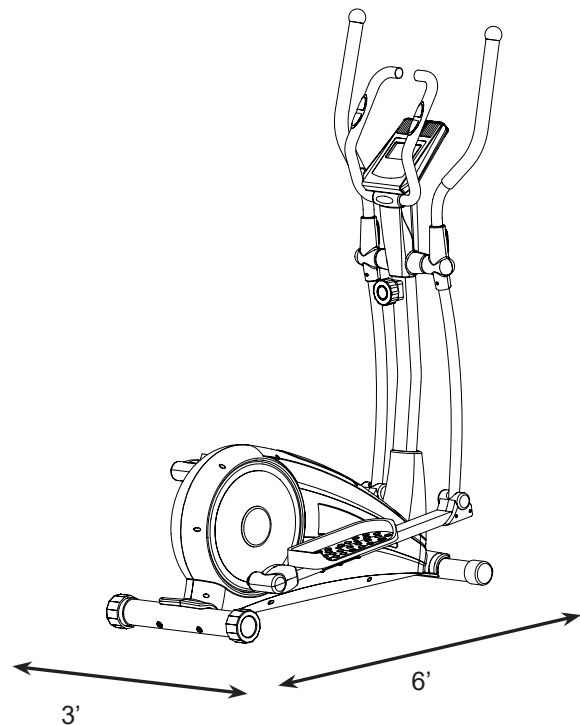
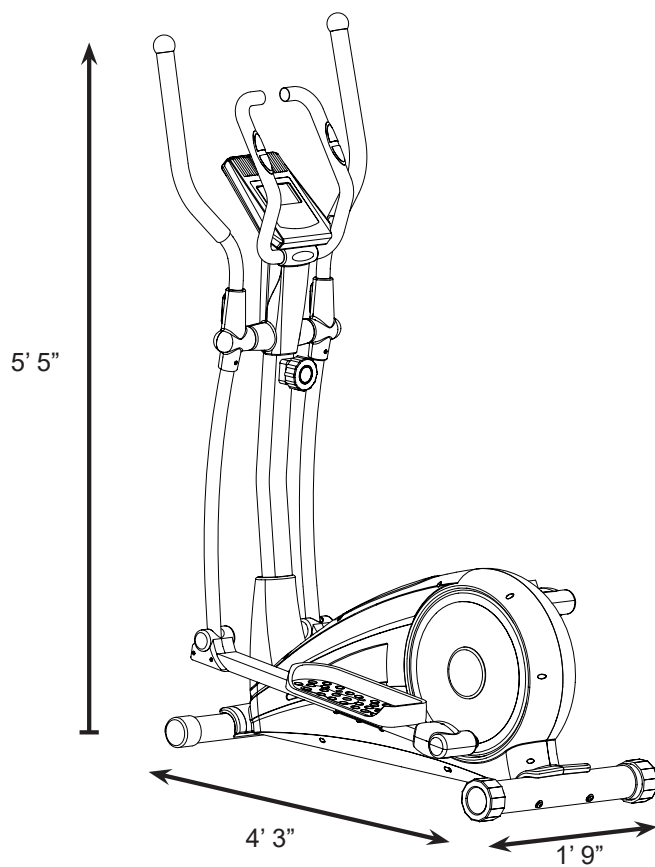

ASSEMBLY INSTRUCTIONS

Assembly of the BFCT1R takes professional installers about 1/2 hour to complete. If this is the first time you have assembled this type of equipment, plan on significantly more time.

PROFESSIONAL INSTALLERS ARE HIGHLY RECOMMENDED!

However, if you acquire the appropriate tools, obtain assistance, and follow the assembly steps sequentially, the process will take time, but is fairly easy.

ASSEMBLY TIPS

Read all "Notes" on each page before beginning each step.

While you may be able to assemble the BFC-T1R using the illustrations only, important safety notes and other tips are included in the text.

Some pieces may have extra holes that you will not use. Use only those holes indicated in the instructions and illustrations.

NOTE: To find out the length of a particular bolt, measure its shank (the long, narrow part beneath the head).

Refer to the following diagram:

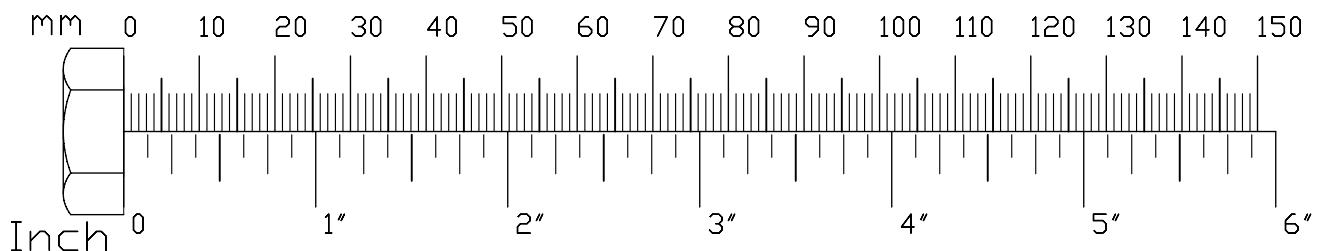
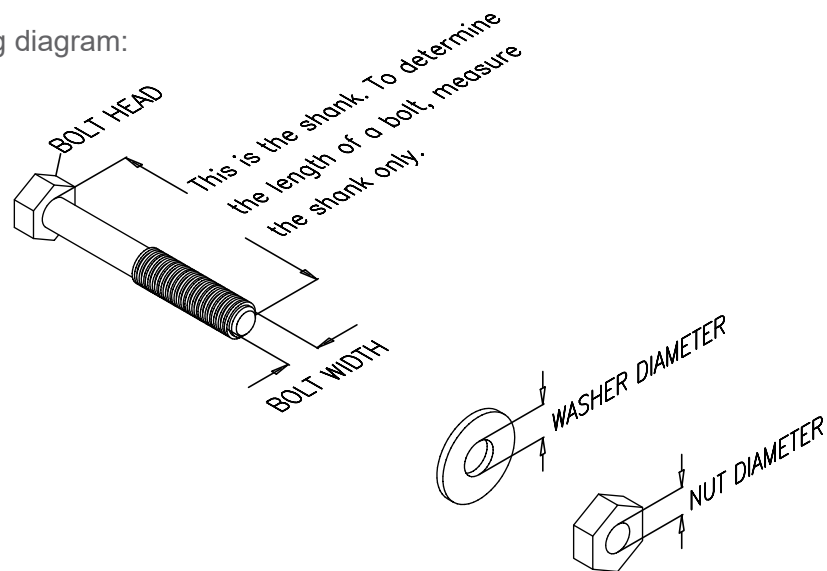

STEP**1**

Be careful to assemble all components in the sequence they are presented.

A. Connect Rear Leg (B) to Main Frame (A) using:

Two 4 (M8x90 round allen head bolt)

Two 58 (M8x25 arc washer)

NOTE: Use the larger 8mm washer.

B. Connect Front Leg (C) to Main Frame (A) using:

Two 21 (M8x72 round allen head bolt)

Two 20 (M8x19 arc washer)

NOTE: Use the smaller 8mm washer.

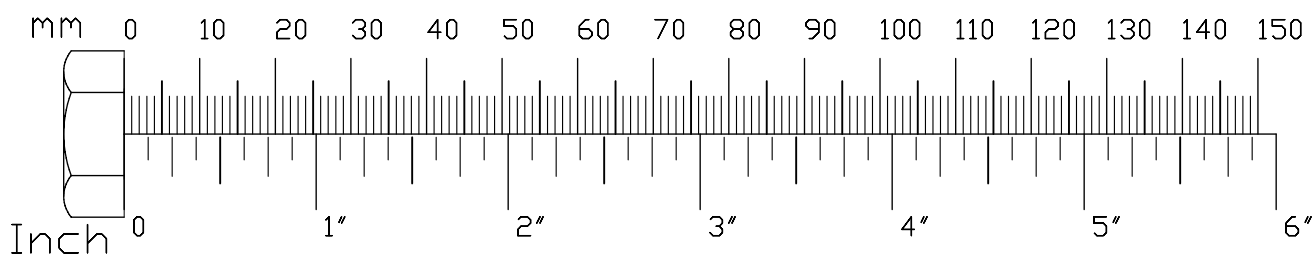

STEP

1

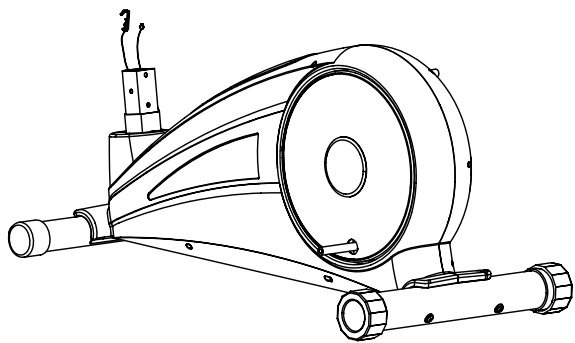

Above shows STEP 1 assembled and completed.

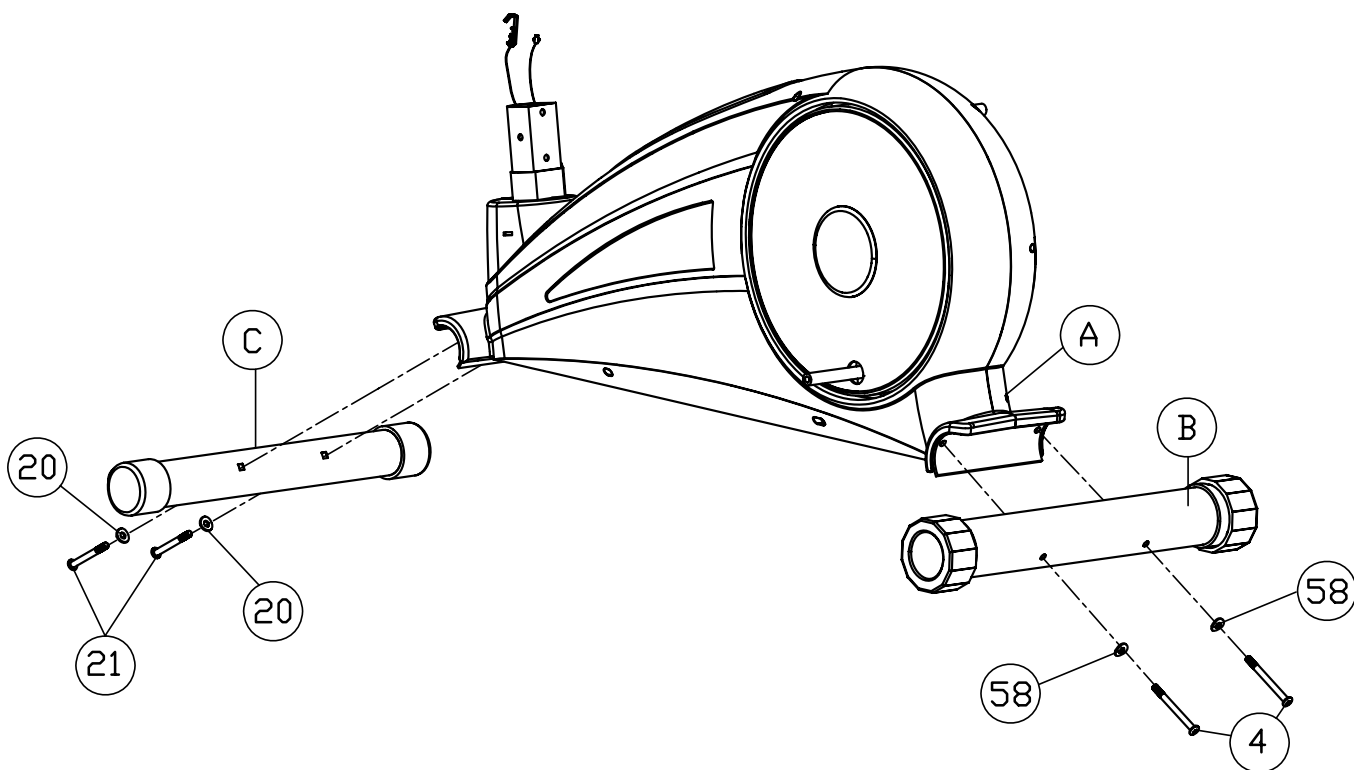

STEP**2**

Be careful to assemble all components in the sequence they are presented.

- A. Slide Shroud (E) onto Upright (D).
- B. Attach Upper Tension Cable (48) to Lower Tension Cable (52) as shown in Diagram 1. Push Upper Tension Cable (48) towards Lower Tension Cable (52) as shown in Diagram 2. Pull the cable up as shown in Diagram 3 then seat it in the slot. Pull out Plastic Component (99) as shown in Diagram 4.
- C. Connect Upper Harness (50) to Lower Harness (53).
- D. Slide Upright (D) onto Main Frame (A) and secure using:
Four 45 (M8x16 round allen head bolt)
Four 44 (M8 spring washer)
Four 12 (M8 washer)
- E. Let Shroud (E) slide to the bottom of Upright (D).

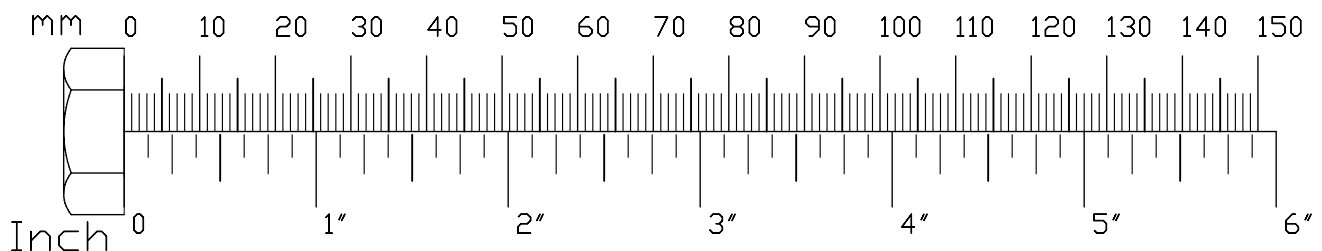

STEP

2

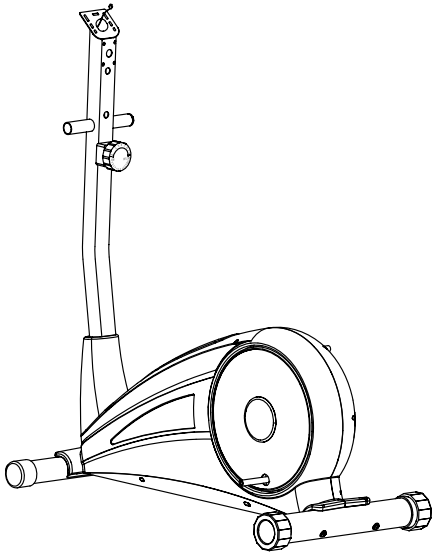

Above shows STEP 2 assembled and completed.

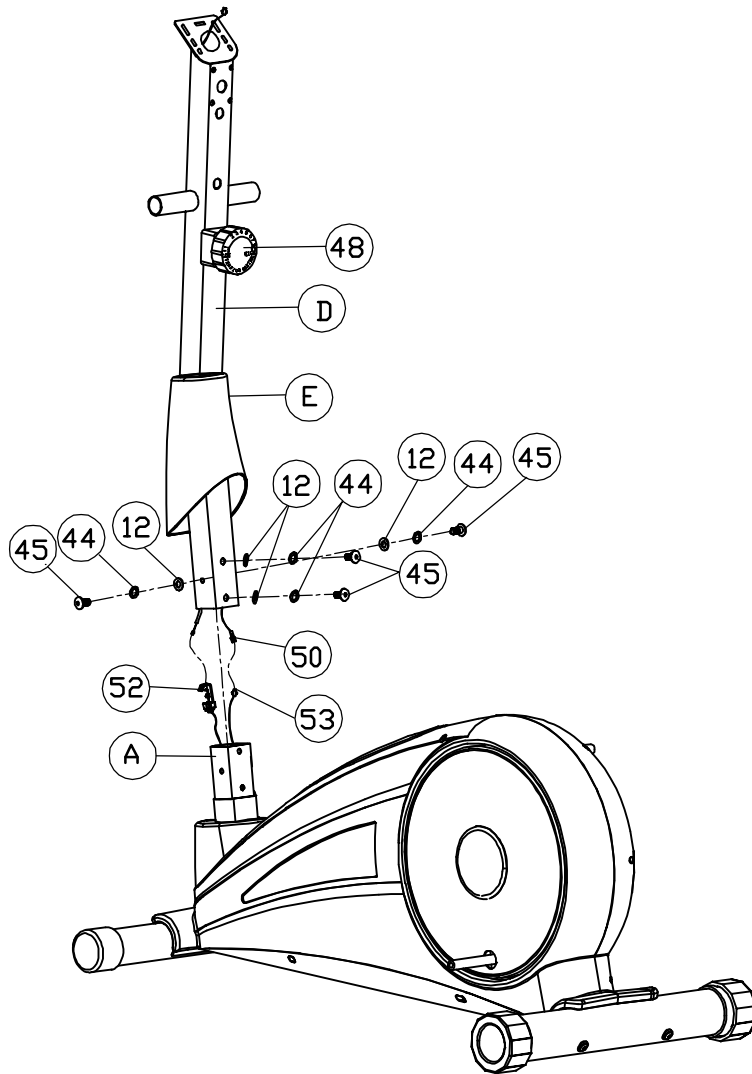
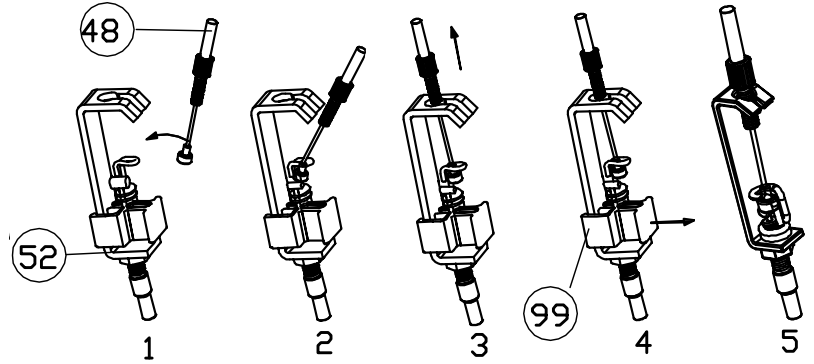

STEP**3**

Be careful to assemble all components in the sequence they are presented.

- A. Insert both Shafts (61) into Upright (D).
- B. Slide Left Stride Bar (F) onto Upright (D) and Left Foot Frame (14) onto Left Crank (55).
- C. Secure Left Stride Bar (F) onto Upright (D) using:
 - One 10 (M10x20 round allen head bolt)**
 - One 11 (M10 spring washer)**
 - One 9 (M16.2 d-washer)**
 - One 35 (M17 wave washer)**
- D. Secure Left Foot Frame (14) onto Left Crank (55) using:
 - One 10 (M10x20 round allen head bolt)**
 - One 11 (M10 spring washer)**
 - One 9 (M16.2 d-washer)**
 - One 35 (M17 wave washer)**
- E. Slide Right Stride Bar (G) onto Upright (D) and Right Foot Frame (15) onto Right Crank (56).
- F. Secure Right Stride Bar (G) onto Upright (D) using:
 - One 10 (M10x20 round allen head bolt)**
 - One 11 (M10 spring washer)**
 - One 9 (M16.2 d-washer)**
 - One 35 (M17 wave washer)**
- G. Secure Right Foot Frame (15) onto Right Crank (56) using:
 - One 10 (M10x20 round allen head bolt)**
 - One 11 (M10 spring washer)**
 - One 9 (M16.2 d-washer)**
 - One 35 (M17 wave washer)**
- H. Insert Left Handle (H) onto Left Stride Bar (F) and secure using:
 - Two 36 (M8x45 carriage bolt)**
 - Two 20 (M8 arc washer)**
 - Two 13 (M8 nylon nut)**
- I. Insert Right Handle (I) onto Right Stride Bar (G) and secure using:
 - Two 36 (M8x45 carriage bolt)**
 - Two 20 (M8 arc washer)**
 - Two 13 (M8 nylon nut)**

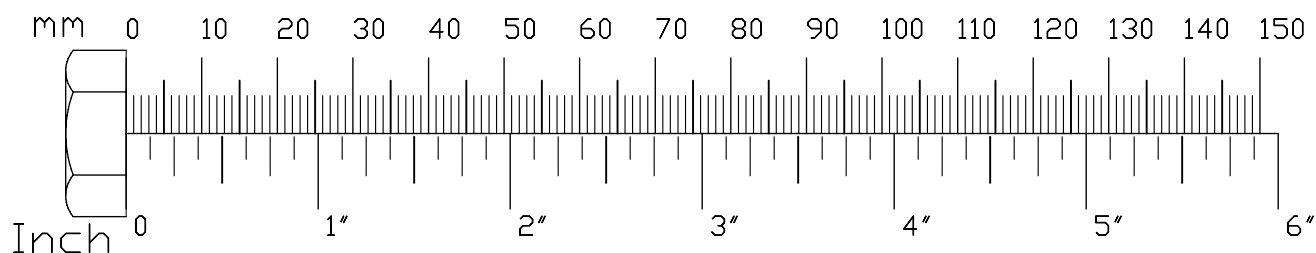

STEP

3

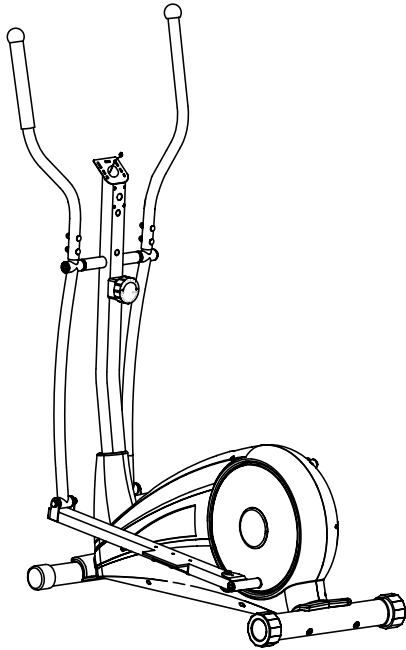

Above shows STEP 3 assembled and completed.

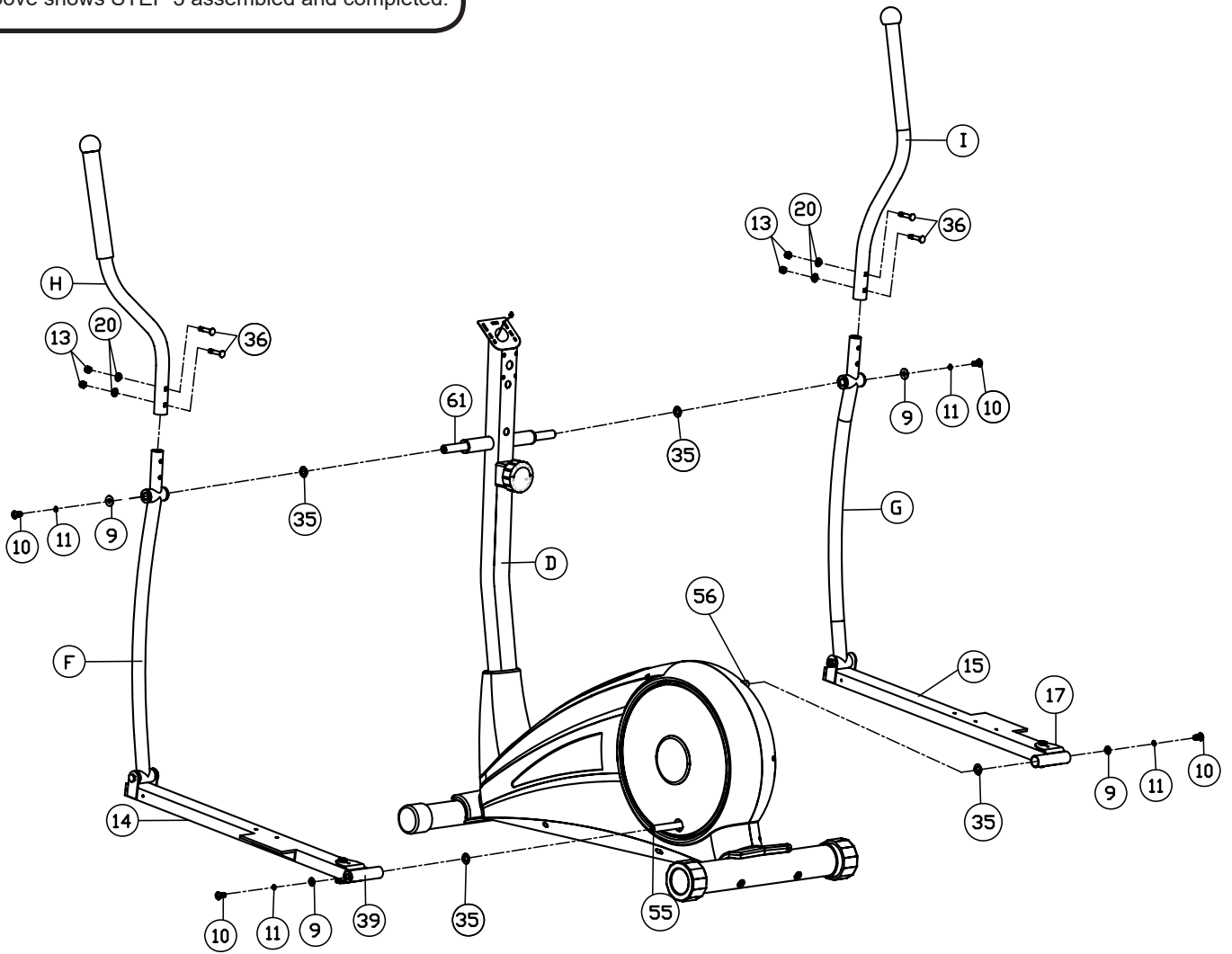

STEP**4**

Be careful to assemble all components in the sequence they are presented.

- A. Connect Left Foot Plate (J) to Left Foot Frame (14) using:
Three 37 (M8x45 hex head bolt)
Three 12 (M8 washer)
Three 13 (M8 nylon nut)
- B. Connect Right Foot Plate (K) to Right Foot Frame (15) using:
Three 37 (M8x45 hex head bolt)
Three 12 (M8 washer)
Three 13 (M8 nylon nut)

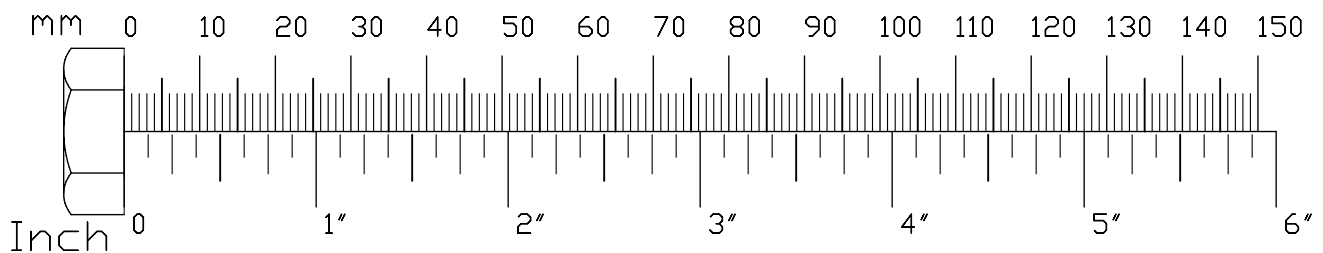

STEP

4

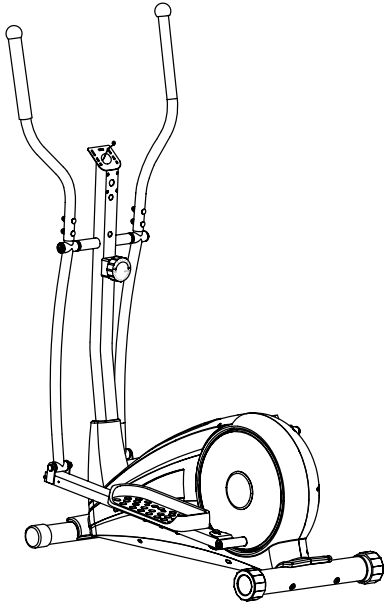

Above shows STEP 4 assembled and completed.

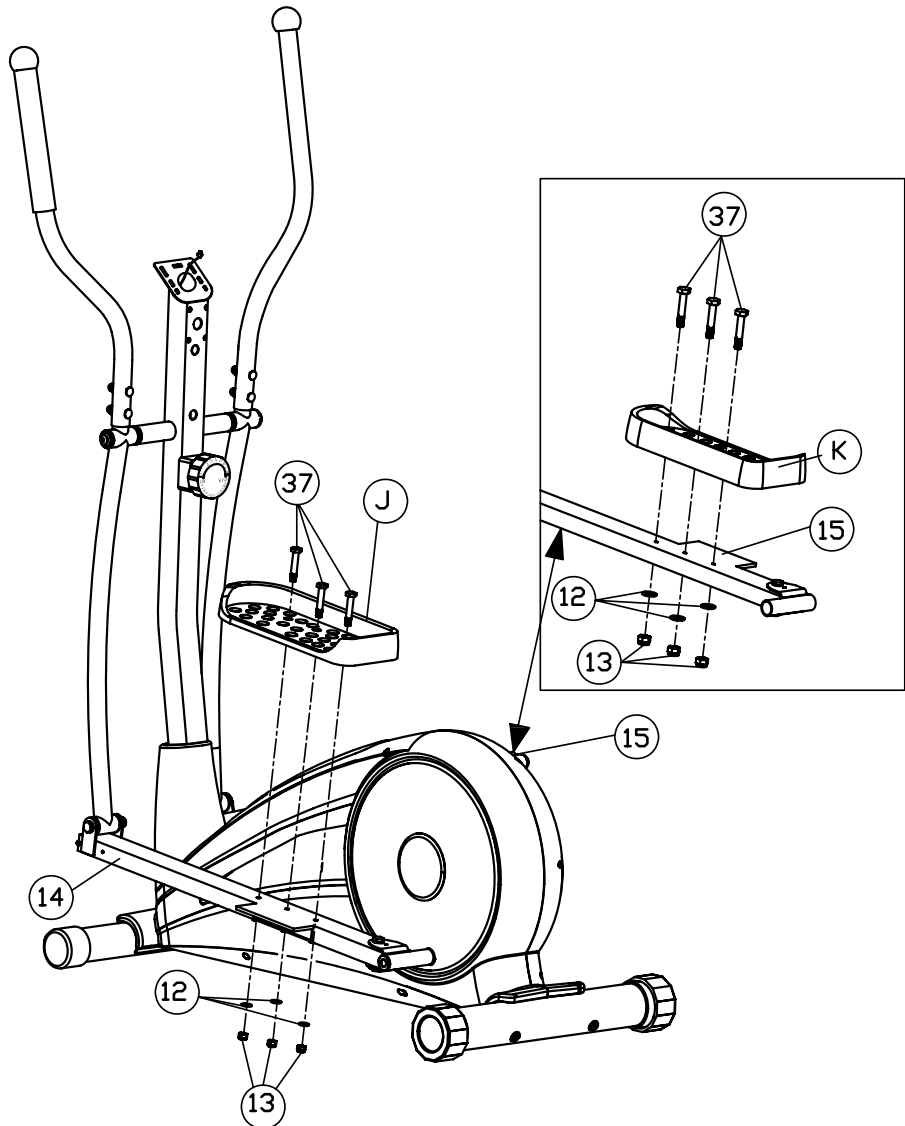

STEP**5**

Be careful to assemble all components in the sequence they are presented.

- A. Route Upper Cable Harnesses (43) through the hole in Upright (D) then up as shown. Let Upper Cable Harnesses (43) hang from the top of Upright (D).
- B. Secure Handle Bar (L) to Upright (D) using:
Four 45 (M8x16 round allen head bolt)
Four 44 (M8 spring washer)

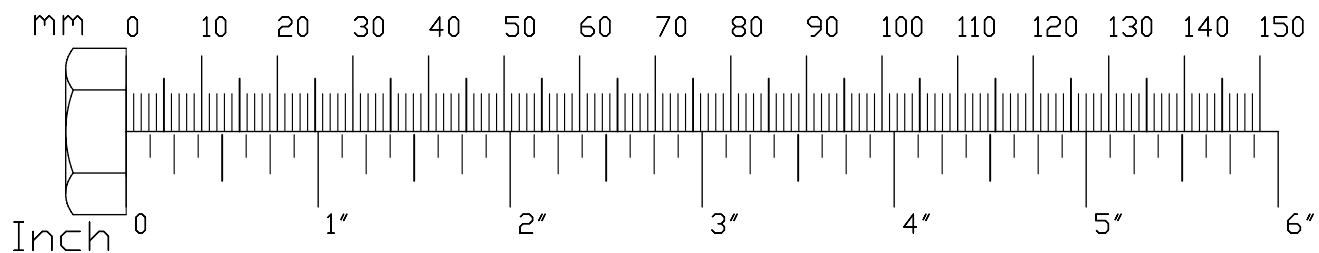

STEP

5

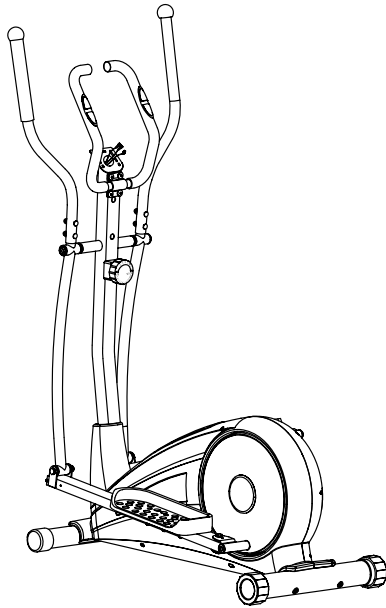

Above shows STEP 5 assembled and completed.

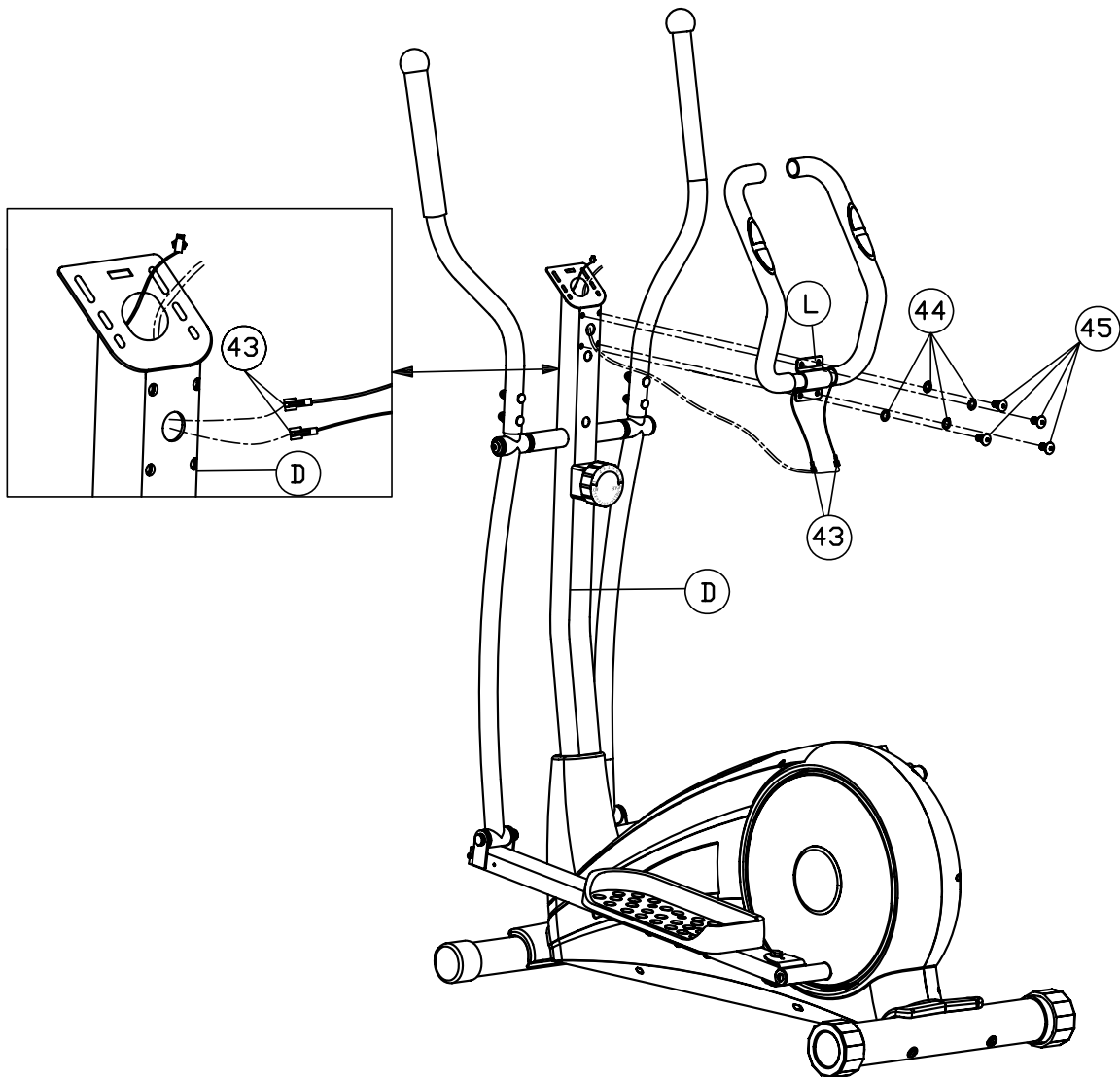

STEP**6**

Be careful to assemble all components in the sequence they are presented.

NOTE: Plastic needs to be pinched to release clip.

- A. Connect Lower Foot Frame Shroud (S) and Upper Foot Frame Shroud (T) to Left Joint Frame (39) and secure using:
Two 16 (M5x10 cross pan head screw)
- B. Connect Lower Foot Frame Shroud (S) and Upper Foot Frame Shroud (T) to Right Joint Frame (17) and secure using:
Two 16 (M5x10 cross pan head screw)
- C. Connect Left Stride Shroud (R) and Right Stride Shroud (Q) to the pivot between Left Stride Bar (F) and Left Foot Frame (14) and secure using:
Four 59 (ST4.2x18 phillips head screw)
- D. Connect Left Stride Shroud (R) and Right Stride Shroud (Q) to the pivot between Right Stride Bar (G) and Right Foot Frame (15) and secure using:
Four 59 (ST4.2x18 phillips head screw)
- E. Connect Left Front Handle Shroud (M) and Left Rear Handle Shroud (P) to the pivot between Left Handle (H) and Left Stride Bar (F) and secure using:
Two 27 (ST3.5x10)
- F. Connect Right Rear Handle Shroud (O) and Right Front Handle Shroud (N) to the pivot between Right Handle (I) and Right Stride Bar (G) and secure using:
Two 27 (ST3.5x10)

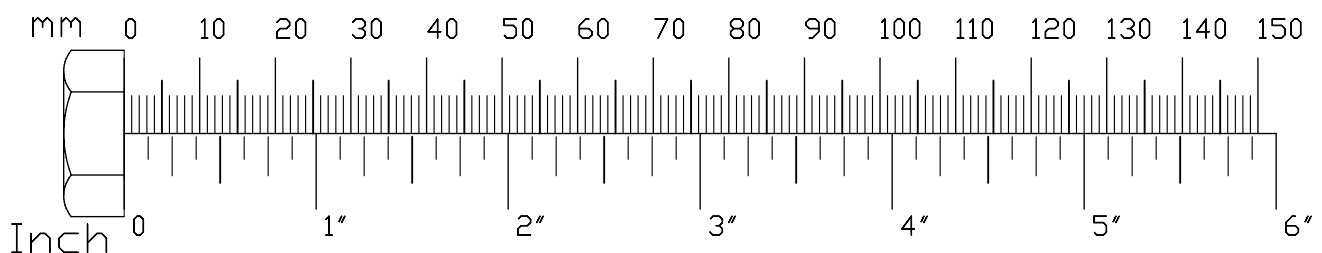

STEP

6

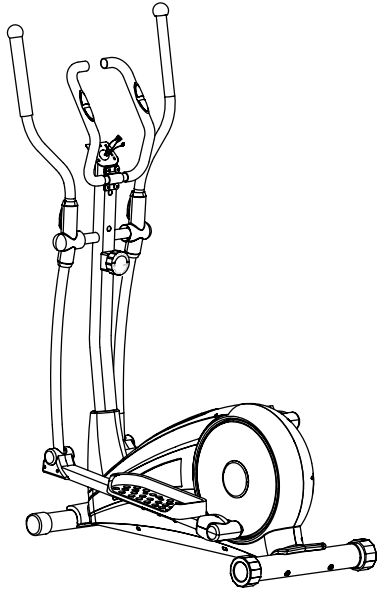

Above shows STEP 6 assembled and completed.

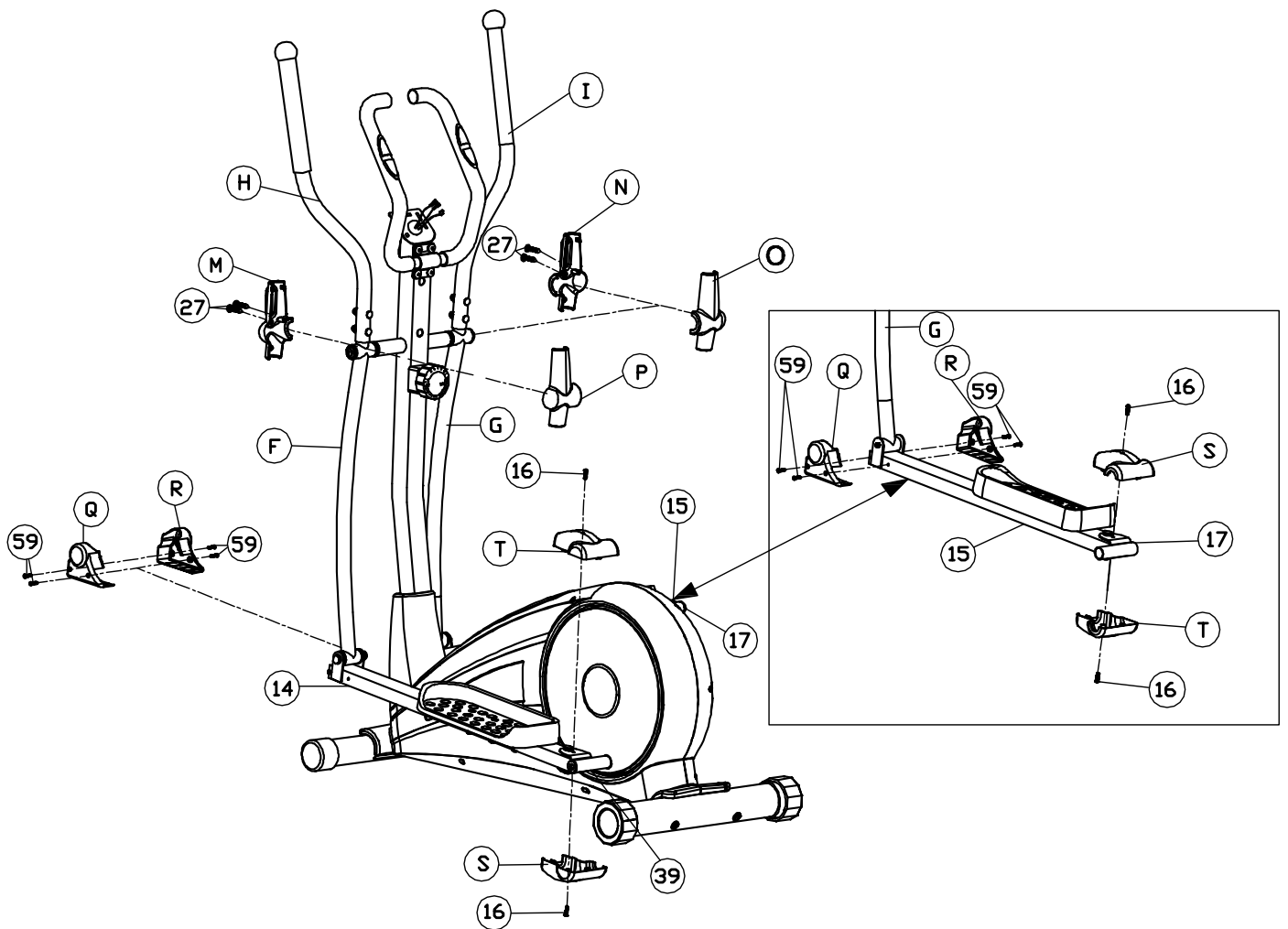

STEP**7**

Be careful to assemble all components in the sequence they are presented.

- A. Slide Console (31) onto Upright (D).
- B. Secure Console (31) to Upright (D) using:
Two 57 (M4x10 cross pan head screw)
Two 60 (M5 washer)
- C. Connect Rear Upright Shroud (V) and Front Upright Shroud (U) to Upright (D) and secure using:
Two 59 (ST4.2x18 phillips head screw)
- D. Connect HR Cable Harness (43) and Upper Harness (50) to Console (31).

NOTE: Carefully fit the wires back into the hole in Upright (D) before securing the console.

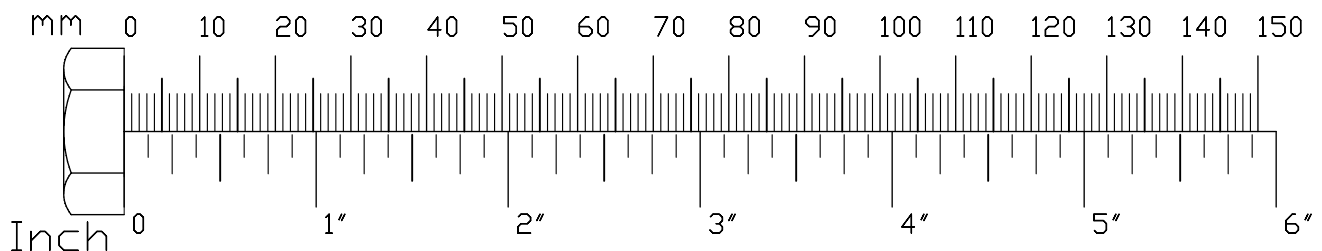

STEP

7

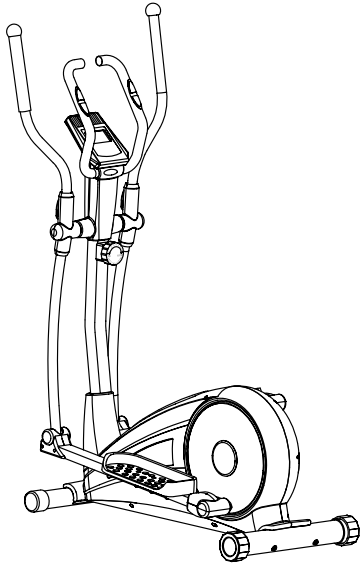

Above shows STEP 7 assembled and completed.

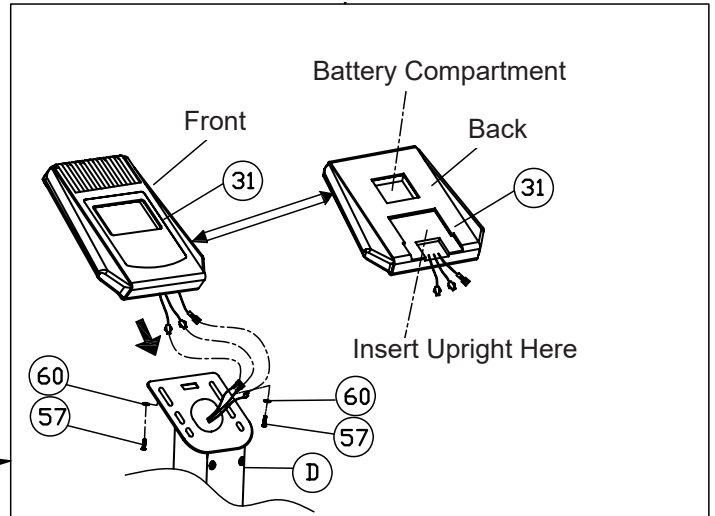
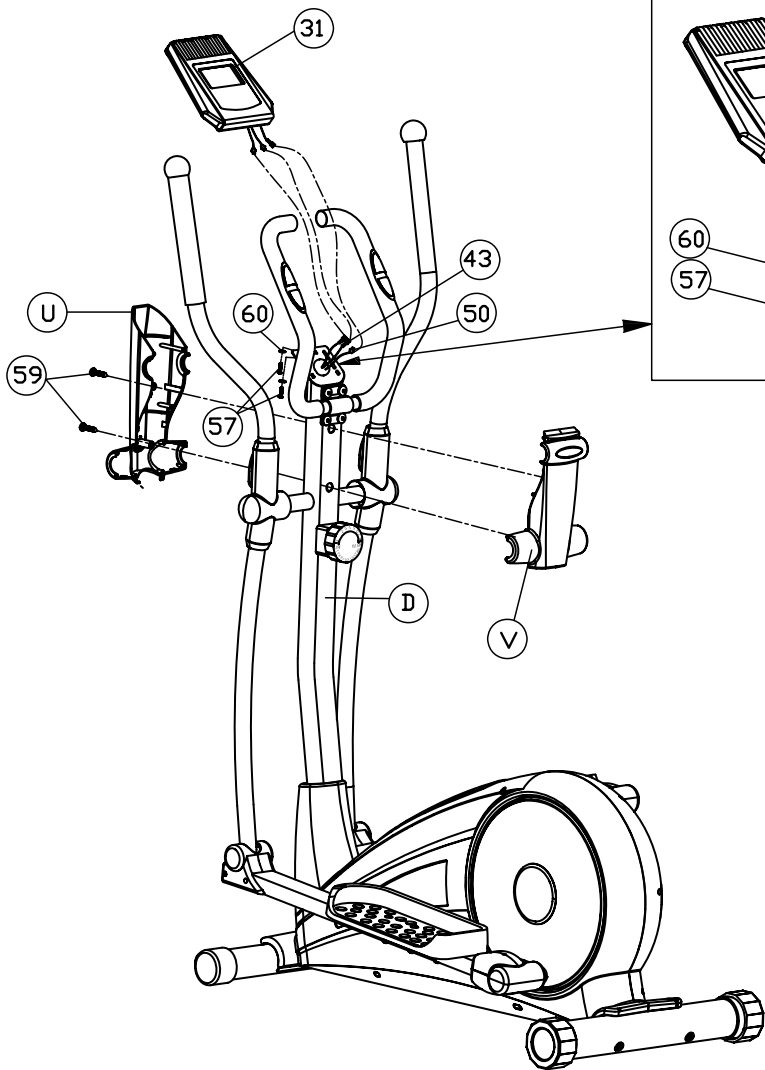

SETTING UP YOUR BFCT1R

PLACEMENT IN YOUR HOME

To make exercise a desirable daily activity for you, the BFCT1R should be placed in a comfortable and attractive setting. This cross trainer is designed to use minimal floor space and to fit nicely in your home.

- Do not place or operate the BFCT1R outdoors.
- Do not place the BFCT1R near water or in high moisture content environment.
- It is highly recommended to place a dedicated equipment mat beneath your BFCT1R. A dedicated mat provides superior stability and firmness for a proper workout.

MOVING THE BFCT1R

This cross trainer is easy to move around safely. To move the BFCT1R:

1. Grasp the Handles.
2. Carefully pull the handles towards you while pushing the front of the cross trainer downward.
3. Simply roll the BFCT1R on its two wheels to the desired location.

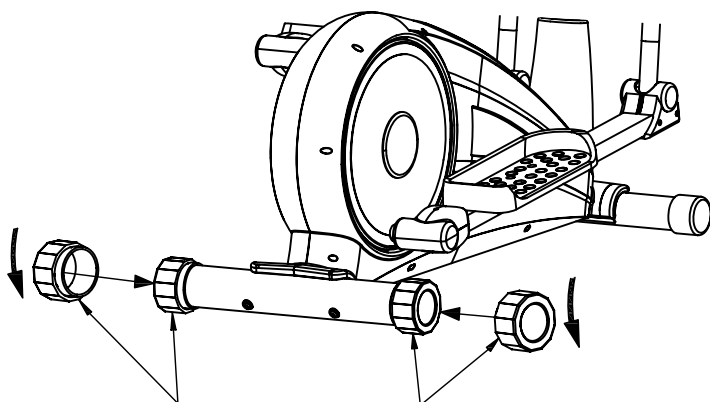
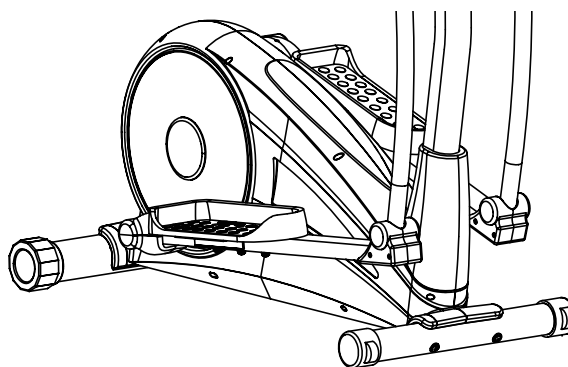

LEVELING THE BFCT1R

The Rear Leg End Caps can be adjusted to level the BFCT1R:

1. Rotate the Rear Leg End Cap clockwise or counter-clockwise to adjust the level of the cross trainer.

SETTING UP YOUR BFCT1R

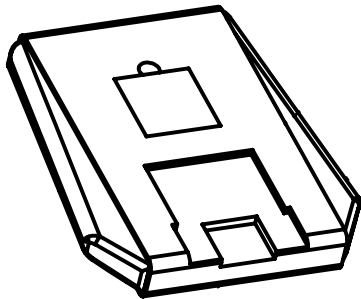

To install the Console batteries (1),
remove Battery Cover (32).

Insert two AA batteries into the
console. Observe polarity. →

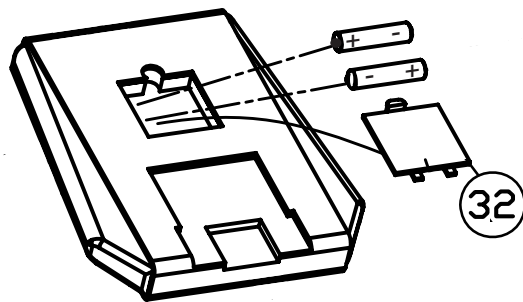

After battery installation,
reinstall the console's Battery Cover (32).

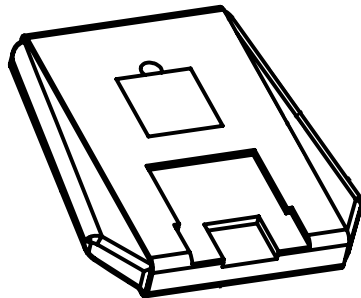

Adjust TENSION CONTROL by rotating the
TENSION CONTROL knob.
Rotate clockwise to increase tension.
Rotate counter-clockwise to decrease tension. →

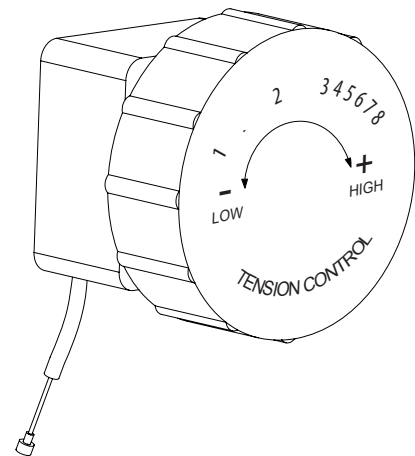

CONSOLE FEATURES

The console informs the user with valuable information about the workout and allows the user to control workout resistance levels. Please become familiar with the console before your first exercise session.

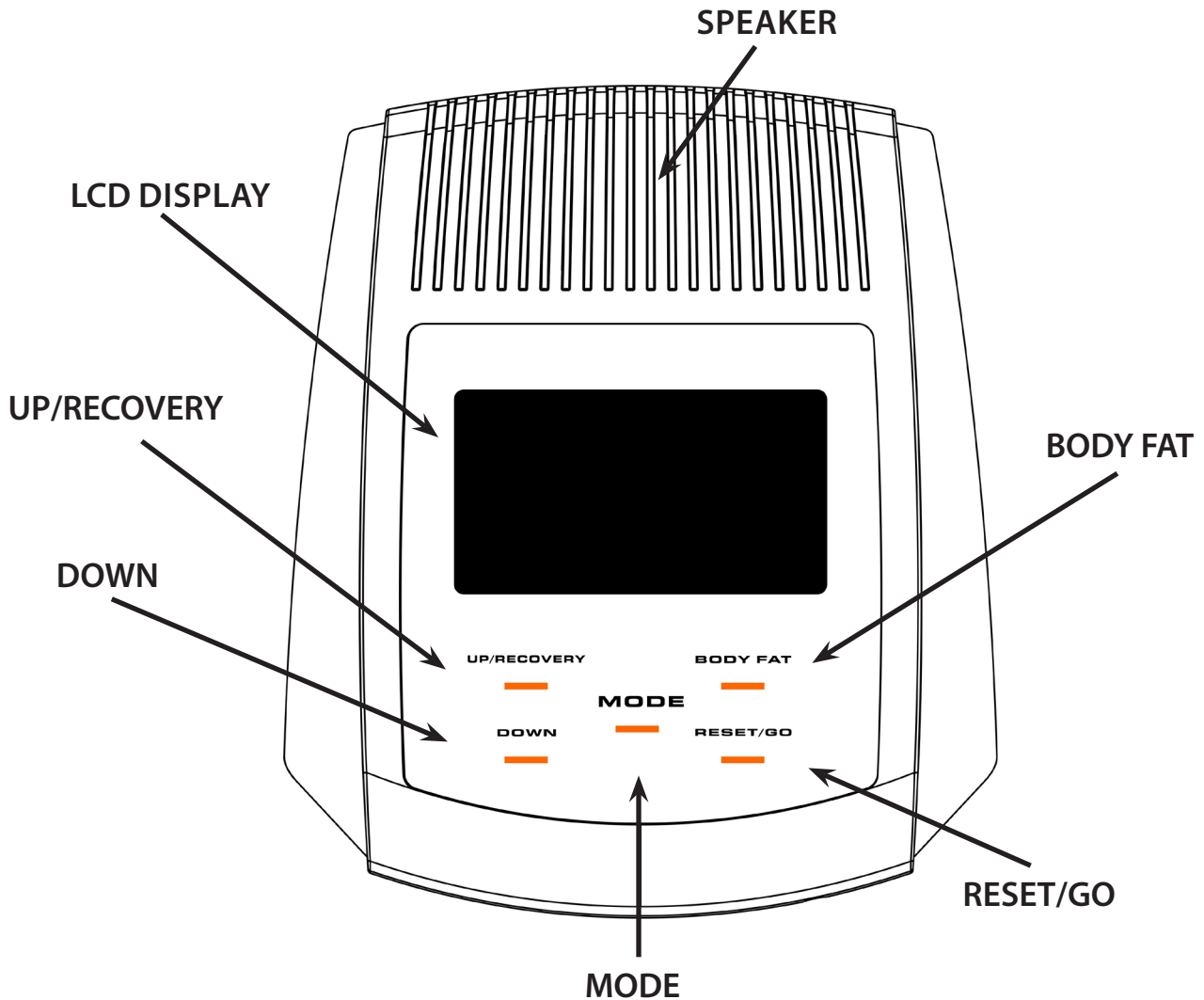

Feature	Description
LCD Display	Console screen
MODE	Cycle through console programming
BODYFAT	Calculate Body Fat percentage, BMI and BMR
RESET/GO	Reset the display/value
UP/RECOVERY	Increases a value (<i>Time, Age, Distance, Calories</i>)
DOWN	Decreases a value (<i>Time, Age, Distance, Calories</i>)

CONSOLE DISPLAY FEATURES

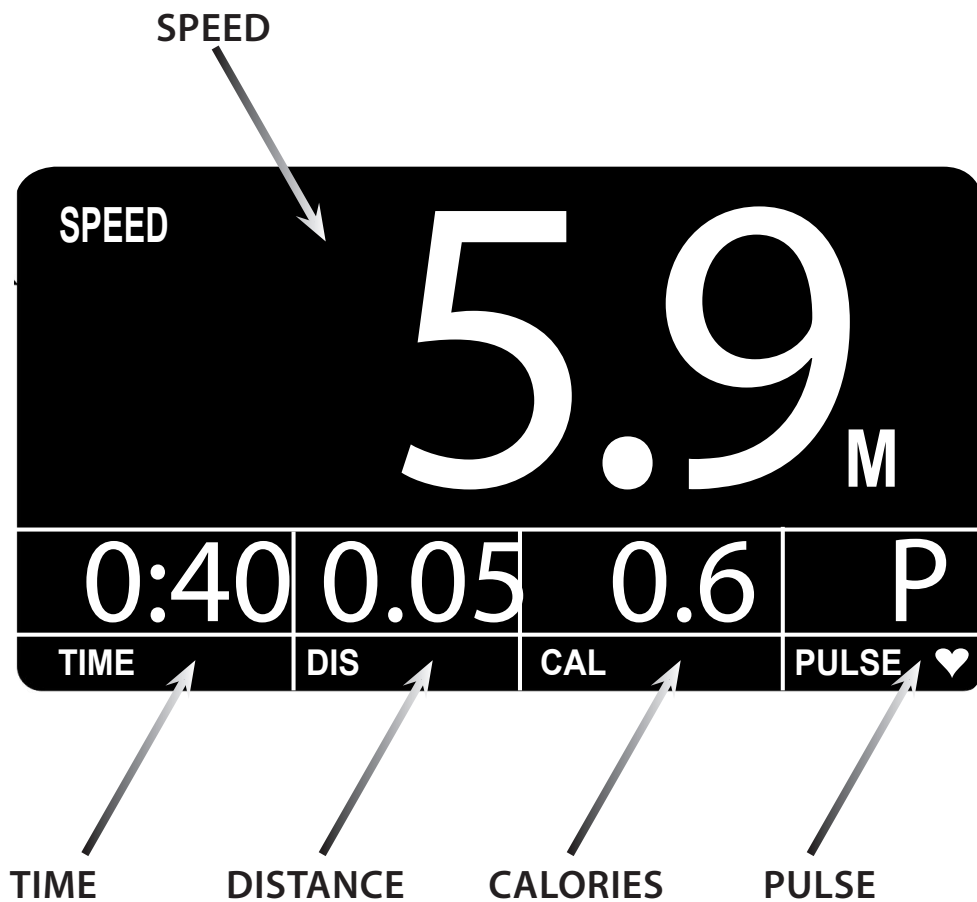

Feature	Range	Specification
Speed	0.0 ~ 99.9 mph	0.1 Mile/Hour
Time	0.00 ~ 99.59 s	1 Second
Calories	0 ~ 999 Calories	0.1 ~ 1 Calorie
Hand Pulse	40 ~ 240 bpm	1 Beat/Minute
Distance	0 ~ 9.99mi ~ 99.9 mi	0.01 ~ 0.1 Mile

CONSOLE OPERATION

PROGRAMMING THE DISPLAY

The display is able to be programmed to establish customized workout goals. The BFCT1R gives users the power to control their workout time, distance travelled and total calorie loss.

Press **MODE** once to program the console.

If the console is in **STAND BY** mode, the display will initially reset.

*After leaving **STAND BY** mode, the display was reset.* →

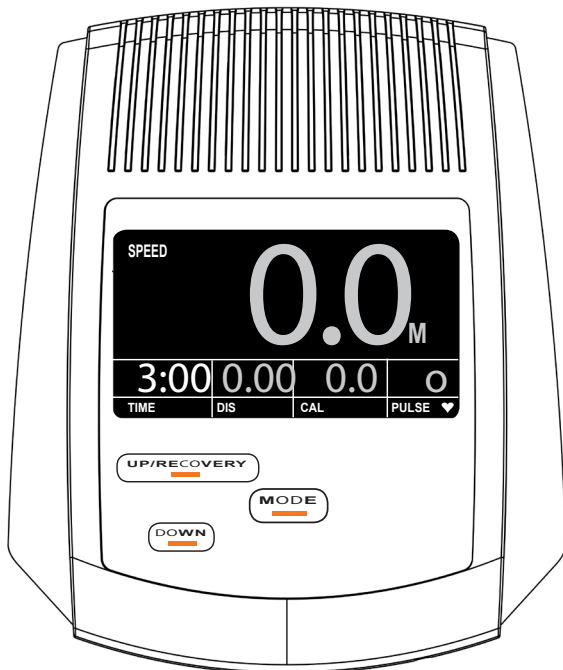
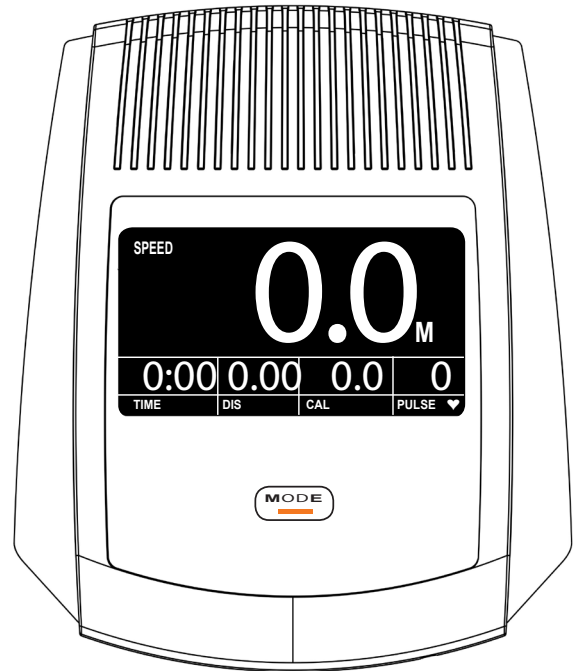

As the **TIME** window flashes, enter the pre-set **TIME** by pressing **UP/RECOVERY** or **DOWN** to increase/decrease the set value to reach your desired time.

Again press the **MODE** button to advance to the next function.

← *The display is set for a 3:00 minute workout.*

As the **DISTANCE** window flashes, enter the pre-set **DISTANCE** by pressing **UP/RECOVERY** or **DOWN** to increase/decrease the set value to reach your desired distance.

Again press the **MODE** button to advance to the next function.

The display is set for a distance of 2.5 mi. →

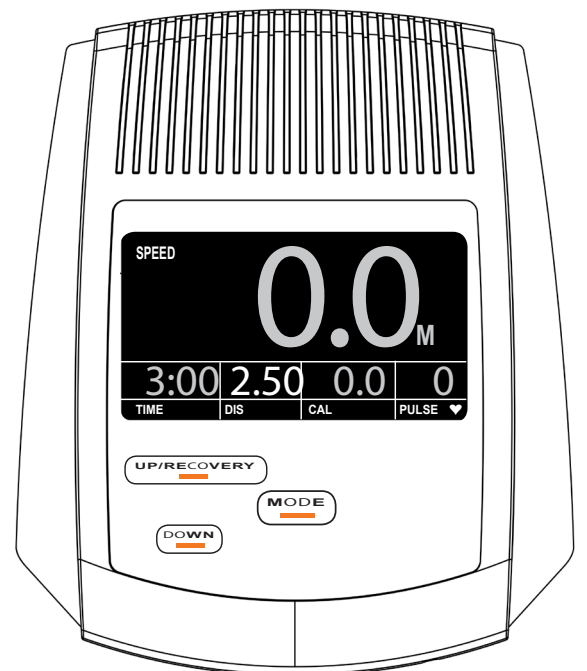

CONSOLE OPERATION

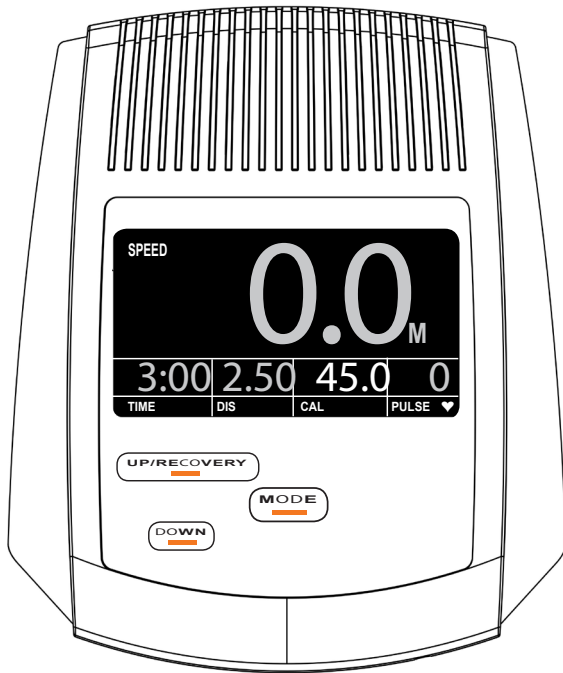

As the CALORIE window flashes, enter the pre-set CALORIES by pressing **UP/RECOVERY** or **DOWN** to increase/decrease the set value to reach your desired calorie setting.

Again press the **MODE** button to advance to the next function.

← *This workout will burn 45 calories.*

The TEMPERATURE mode can be set according to specific needs. Maintaining the correct ambient temperature during a workout will increase the effectiveness of the exercise.

Enter the desired TEMPERATURE readout (Celsius or Fahrenheit) by pressing **UP/RECOVERY** or **DOWN** to change between Celsius or Fahrenheit. Press the **MODE** button to complete programming the display.

The display is set for Fahrenheit. →

Start your workout!

The programmed sections of the display will start counting down as the exercise progresses. When one of the target goals has been achieved, the programmed window will flash and the console will beep advising the user of their accomplishment. After the achievement, the display will count up and record further workout progress.

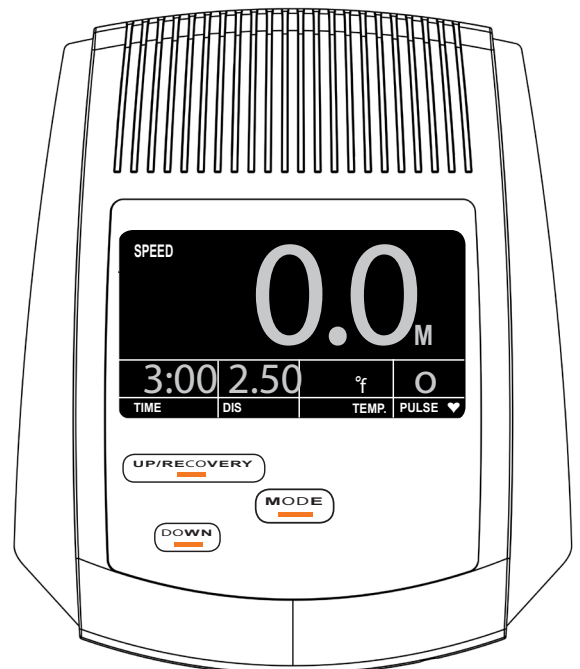

CONSOLE OPERATION

BODYFAT, BMI & BMR

The BFCT1R console has the ability to measure a person's BODYFAT, BMI and BMR. BMI (Body Mass Index) is a statistical measurement of body weight based on a person's weight and height. Though it does not actually measure the percentage of body fat, it is used to estimate a healthy body weight and used as a diagnostic tool to identify weight problems. BMR (Basal Metabolic Rate) determines your daily calorie needs.

While *not* exercising, press **BODY FAT** to enter the Body Fat parameters settings.

The calculation is performed while not exercising. Speed is 0 mph. →

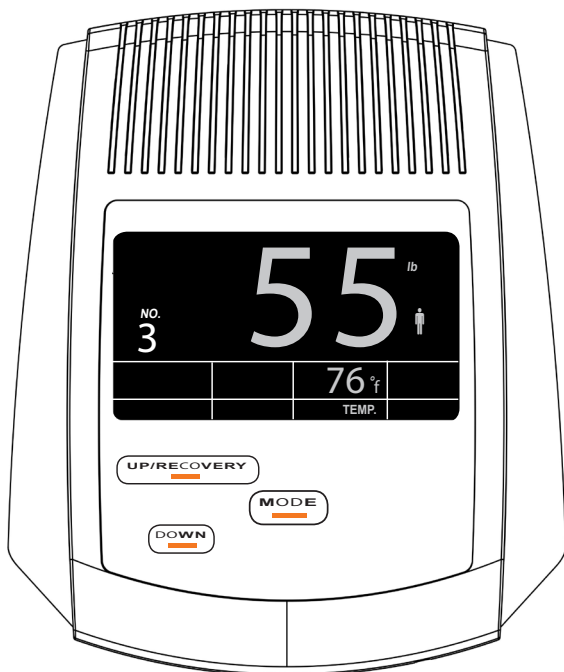
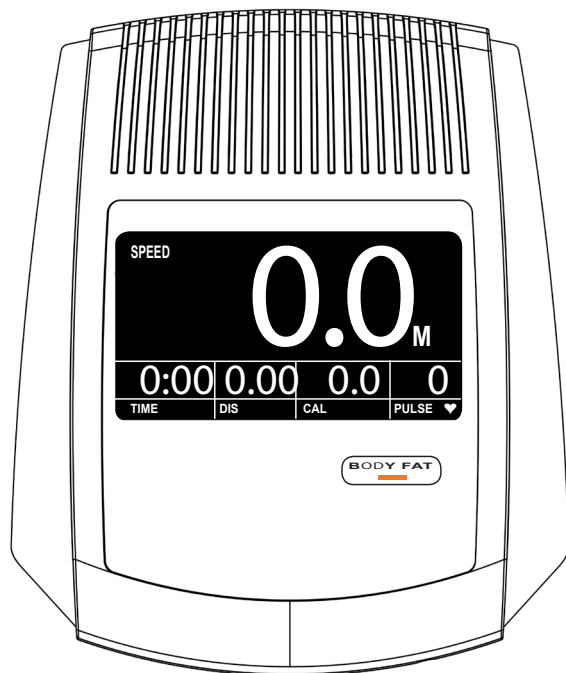

Multiple users can examine their BODYFAT. Enter the USER ID number from 1 to 8 by pressing **UP/RECOVERY** or **DOWN** to increase/decrease the USER ID. Press **MODE** to advance to next parameter setting.

← *The display will calculate BODYFAT for user number 3.*

Enter your WEIGHT (LB) by pressing **UP/RECOVERY** or **DOWN** to increase/decrease your set weight. Press **MODE** to advance to the next parameter setting.

Weight is set at 95 lb. →

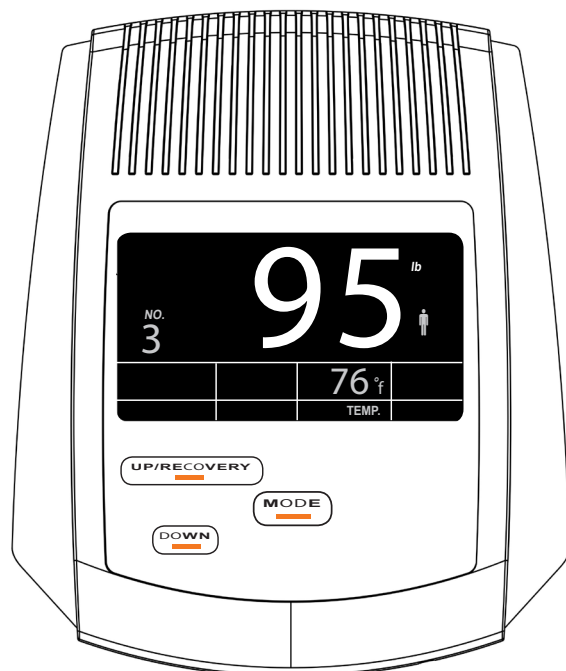

CONSOLE OPERATION

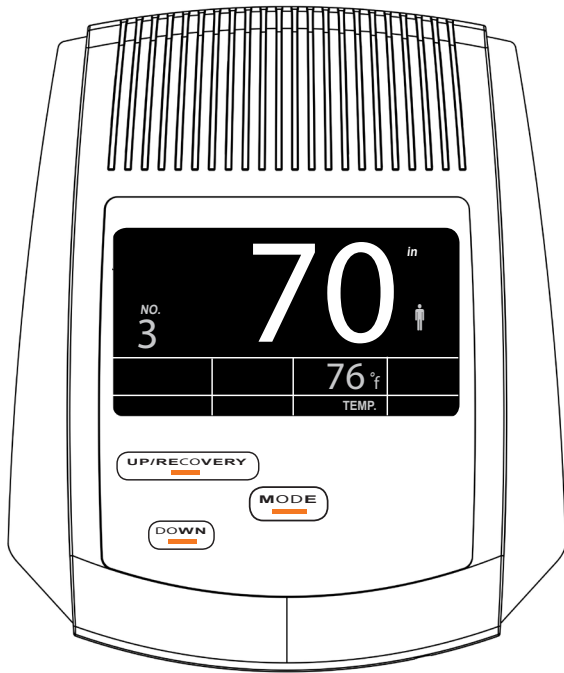

Enter your HEIGHT (inch) by pressing **UP/RECOVERY** or **DOWN** to increase/decrease your set height. Press **MODE** to advance to the next parameter setting.

← *The height of USER 3 is set at 70".*

Enter your AGE (YEAR) by pressing **UP/RECOVERY** or **DOWN** to increase/decrease your age setting. Press **MODE** to proceed to next parameter setting.

USER 3 is 29 years old. →

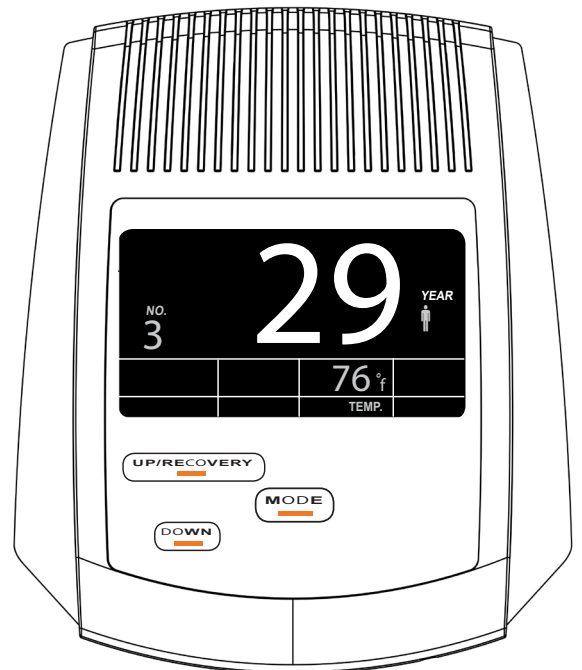

Enter your SEX by pressing **UP/RECOVERY** or **DOWN** to select between male and female.

After having entered the parameters, press the **RESET/GO** button then hold onto the Heart Rate Contacts.

← *USER 3 is female.*

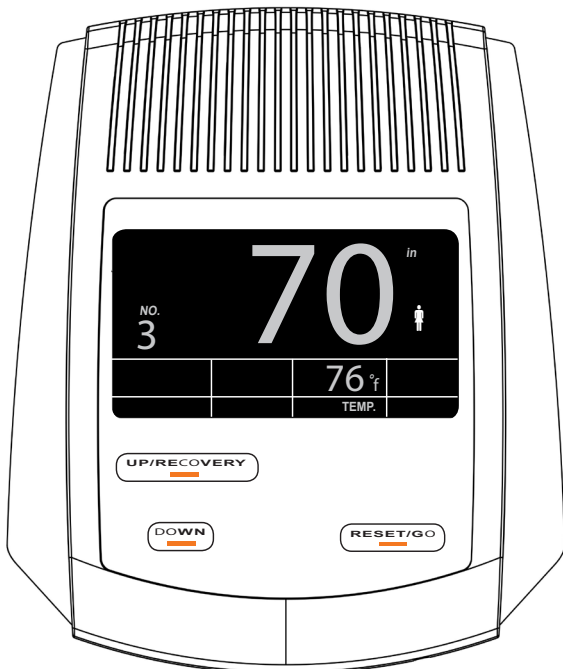

CONSOLE OPERATION

After 6 seconds, the console will display the executed calculation on the display. The display will show BODYFAT, BMI and BMR. To exit the application, press the **BODY FAT** button.

USER 3 has 21.8% BODYFAT, a BMI of 22 and a BMR of 1640 calories. →

NOTE: The display will exit the BODYFAT test automatically if no console operation has been detected for a period of 10 seconds and will display the Er.1 error code.

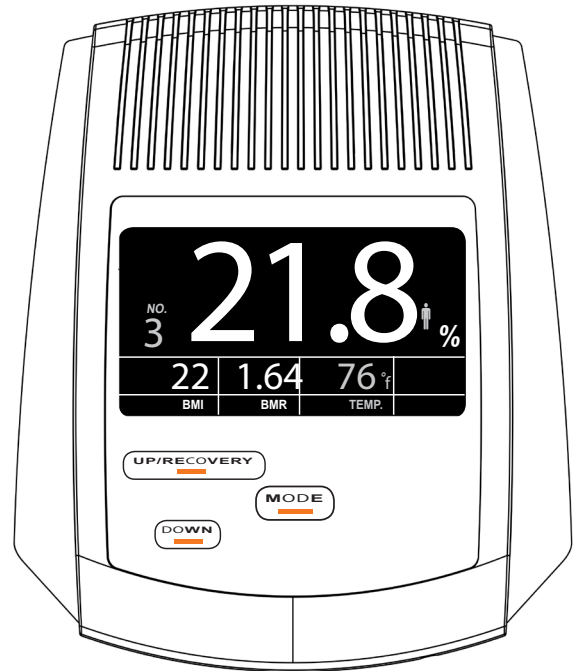

BODYFAT PARAMETERS

The chart below is used to reference your BODYFAT results. Results are for therapeutic purposes only.

Gender/Age	Underweight	Healthy	Slightly Overweight	Overweight	Obese
Male ≤ 30 years	<14%	14% ~ 20%	20.1% ~ 25%	25.1% ~ 35%	> 35%
Male > 30 years	<17%	17% ~ 23%	23.1% ~ 28%	28.1% ~ 38%	> 38%
Female ≤ 30 years	<17%	17% ~ 24%	24.1% ~ 30%	30.1% ~ 40%	> 40%
Female > 30 years	<20%	20% ~ 27%	27.1% ~ 33%	33.1% ~ 43%	> 43%

BMI INDEX

The chart below is used to reference your BMI (Body Mass Index) results. Results are for therapeutic purposes only.

Underweight	Healthy	Slightly Overweight	Overweight	Obese
≤ 18	18.5 ~ 24.9	25 ~ 26.9	27 ~ 29.9	≥ 30

SLEEP MODE

The BFCT1R will enter SLEEP MODE mode when left un-operational for eight minutes after a workout. While SLEEP MODE mode is active, the console will display the current ambient temperature. Press **MODE** once to reset the display and start your workout. All memory is cleared during SLEEP MODE except for BODYFAT parameters and Temperature.

CONSOLE OPERATION

PULSE RATE

Your BFCT1R comes equipped with Heart Rate Contacts. The Heart Rate Contacts send your heart rate information to the console for processing. To measure Heart Rate, your hands need to firmly grasp the entire area of the Heart Rate Contact Sensors on both sides of the handlebar. There is no need to hold onto the contacts very tightly although holding onto the contacts loosely may produce a false readout.

Before measuring your pulse rate, make sure the PULSE window shows 'P' instead of '0'. The readout may show '0' after a brief period of pulse reading inactivity. Press any button to change '0' into "P" to activate the pulse readout. Place both of your palms on the Heart Rate Contact Pads and the monitor will show your current heart rate in beats per minute (BPM) after a 3~4 second calculation time.

During the Heart Rate reading, because of the contact jamming phenomenon, the measured Heart Rate value may be higher than your actual pulse rate during the first 2~3 seconds, then will stabilize to a normal level.

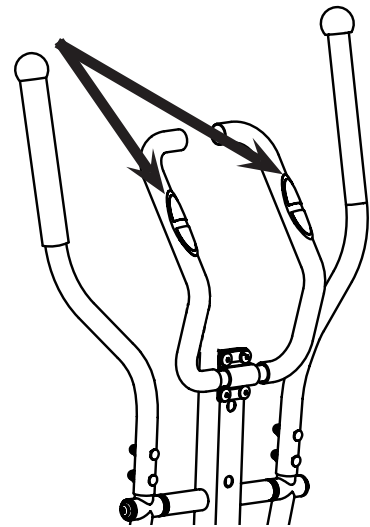

PULSE RECOVERY

PULSE RECOVERY is an excellent guide for many types of training regimes that use recovery heart rate as a progress guide and to spot problems such as over-heating or dehydration.

First, test your pulse as mentioned in the PULSE RATE section. Then, while not exercising (SPEED is 0 mph), press

UP/RECOVERY

to enter the PULSE RECOVERY function.

The display will show a 1 minute count-down as well as your current pulse rate. Hold on to the Heart Rate Contacts until the display counts down to zero. The console will now display your pulse recovery level from F1 to F6. Press **UP/RECOVERY** again to exit the PULSE RECOVERY function.

The Pulse Recovery is at the F2 level. →

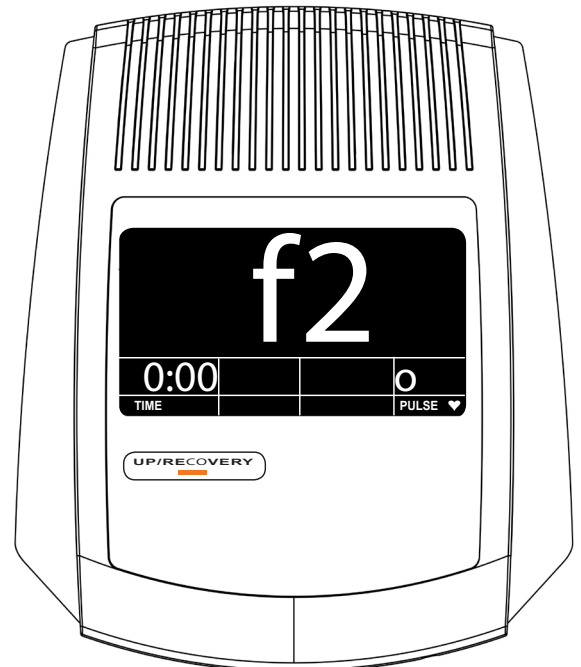

The chart below is used to reference your PULSE RECOVERY level. Results are for therapeutic purposes only.

Fastest	Fast	Quick	Moderate	Slow	Slowest
F1	F2	F3	F4	F5	F6

EXERCISE TIPS AND GUIDELINES

Always consult your physician before beginning any exercise program. For your health and safety, do not over exert yourself. Remember to stretch and warm up before each exercise program.

STRETCH

Stretching prior to exercising will improve flexibility and reduce chances of exercise related injury. Ease into each of these stretches with a slow gentle motion. Hold your stretched position for a count of ten. Do not bounce. Repeating the stretching exercises again, after the cool down, will help to loosen and relax your muscles to prevent soreness after your workout.

WARM UP

A few minutes of a work out should be devoted to warming up. This warm up time will limber your muscles and prepare them for a more strenuous exercise. Warm up on the BFCT1R by exercising at slow speeds.

COOL DOWN

Never stop exercising suddenly. It is a good idea to end a workout slowly since this will allow your heart to readjust to the decreased demand.

HOW OFTEN?

It is most often recommended that you exercise a few times a week to maintain cardiovascular fitness. If you have other goals such as weight or fat loss, you will achieve your goal faster with more frequent exercise. Remember that your ultimate goal should be to make exercise a lifetime habit. Many people are successful staying with a fitness program if they set aside a specific time of the day to exercise. Regular exercise is a key to a healthy life style

HOW LONG?

For a useful workout, always start slowly, especially if you have been sedentary during the past year. Your body will need time to adjust to the new activity. As your body adjusts, gradually increase your workout time per session.

EXERCISE TIPS AND GUIDELINES

If you experience chest pains, nausea, dizziness or shortness of breath, stop exercising immediately and consult your physician before continuing any workouts!

HOW HARD?

How hard you work out is determined by your goal. Regardless of your fitness goals, always begin an exercise program at low intensity. Aerobic exercise does not have to be painful to be beneficial!

There are two ways to measure your exercise intensity. The first is by evaluating your perceived exertion level and the second is by monitoring your heart rate.

During exercise, if you cannot maintain a conversation without gasping, you are working too hard. A good rule of thumb is to work to the point of exhilaration, not exhaustion. If you cannot catch your breath, it is time to slow down. Always be aware of other warning signs to overexertion.

To monitor your heart rate you can use a pulse monitor or take your pulse with your fingers. Pulse monitors are convenient tools for monitoring your heart rate. However, these values are for reference only. You should always listen to your body first.

You can measure your pulse with your fingers by placing your first two fingers lightly over the blood vessel (carotid artery) on your neck located next to your Adam's apple. Count your pulse for ten seconds and multiply by six. This figure is your heart rate in beats per minute (bpm). Compare this number to the Target Heart rate zone for your age group.

TARGET HEART RATE

The most common method for calculating your target heart rate is to find your maximum heart rate.

The standard formula for this is:

$$220 - \text{your age} = \text{MAXIMUM HEART RATE.}$$

You DO NOT want to workout at your maximum heart rate.

You want to workout in your target heart rate zone.

Your target heart rate zone is a percentage of your maximum heart rate. The American Heart Association recommends working out at a target heart rate zone of between 60% - 75% of your maximum heart rate.

If you are just beginning an exercise program, exercise near or below the lower limit of your target zone.

Age	Target Zone
20	120 ~ 150
25	117 ~ 146
30	114 ~ 142
35	111 ~ 138
40	108 ~ 135
45	105 ~ 131
50	102 ~ 127
55	99 ~ 123
60	96 ~ 120
65	93 ~ 116
70	90 ~ 113

TARGET HEART RATE

$$\text{LOWER TARGET ZONE LIMIT} = \text{MAXIMUM HEART RATE} \times 0.60$$

$$\text{UPPER TARGET ZONE LIMIT} = \text{MAXIMUM HEART RATE} \times 0.75$$

TROUBLESHOOTING

PROBLEM	TROUBLESHOOTING TIP	SOLUTION
Console will not turn on	<p>Console needs a HARD reset</p> <p>Batteries are low or dead</p> <p>Reverse polarity</p> <p>Damaged console</p>	<p>Remove then reinstall batteries into the console.</p> <p>Replace with fresh batteries.</p> <p>Insert batteries using correct polarity.</p> <p>Replace console.</p>
Crank Arms or Handles are loose	Loose hardware	Using the provided assembly tools, go over the BFCT1R to make sure all assembly hardware is tight.
No resistance	<p>Tension Knob malfunction</p> <p>Magnetic brake is loose</p>	<p>Call for service.</p> <p>Call for service.</p>
The resistance levels seem to be either too hard or too easy	Magnetic brake has shifted	Call for service.
Console button(s) do not respond to touch	Console Overlay	<p>Button(s) may have been damaged from liquids penetrating console overlay or excessive amount of cleaning solution was used.</p> <p>Too much force was used operating the console buttons.</p> <p>Replace console.</p>
No Heart Rate readout on console	Heart Rate harness	Remove the console and verify that the Heart Rate harness is secure.
Heart Rate readout is erratic	<p>Heart Rate contact pressure</p> <p>Contact obstruction</p> <p>Environmental interference</p>	<p>Gripping the Heart Rate contacts too tight may cause calculation readout errors.</p> <p>Try to maintain moderate pressure when holding onto the Heart Rate contacts.</p> <p>Remove all jewelry when using the BFCT1R.</p> <p>Make sure hands are not completely dry.</p> <p>An exercise environment with large motors, computers, fluorescent lighting and high power lines may cause erratic Heart Rate readout.</p>
Unit is unstable or rocks while in use	Levelers	<p>Make sure the unit is on a solid and level surface.</p> <p>Adjust the Rear Leg End Caps to level the unit.</p>
Speed is not calculated on the console	<p>Console Harness</p> <p>Speed Sensor</p> <p>Magnet</p>	<p>Remove the console and verify that all connections are secure and not damaged or pinched.</p> <p>The Speed Sensor may have become dislodged or damaged.</p> <p>Call for service.</p> <p>The Magnet may have become dislodged or damaged.</p> <p>Call for service.</p>
The BFCT1R squeaks or makes a chirping sound	<p>Levelers</p> <p>Assembly hardware</p>	<p>Make sure the unit is on a solid and level surface.</p> <p>Loosen all assembly hardware, grease the bolt threads then tighten hardware.</p>

SERVICING THE BFCT1R

OBTAINING SERVICE

Please use this Owner's Manual to make sure that all parts have been included in your shipment. When ordering parts, you must use the part number and description from this Owner's Manual. Use only Best Fitness replacement parts when servicing this machine. Failure to do so will void your warranty and could result in personal injury.

For information about product operation or service, go to www.bestfitness.com or contact an authorized Best Fitness dealer or a Best Fitness factory-authorized service company or contact Best Fitness customer service at one of the following:

Toll Free: 1-800-556-3113
Phone: 1-708-427-3555
Fax: 1-708-427-3556
Hours: M-F 8:30-5:00 CST
E-Mail: service@bodysolid.com

Or write to:

BEST FITNESS
Service Department
1900 S. Des Plaines Ave.
Forest Park, IL 60130 USA

Retain this Owner's Manual for future reference.



www.BestFitness.com

HARDWARE

(Actual Size Shown)



Part# 59 ST4.2x18 Phillips Head Screw

Qty. 33

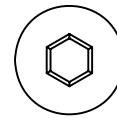
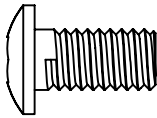

Part# 45 M8x16 Round Allen Head Bolt

Qty. 8

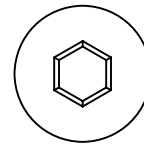
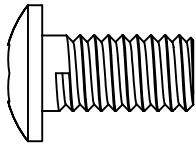

Part# 10 M10x20 Round Allen Head Bolt

Qty. 4

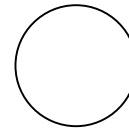
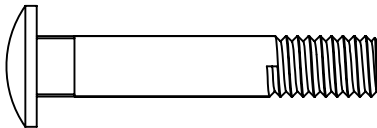

Part# 36 M8x45 Carriage Bolt

Qty. 4

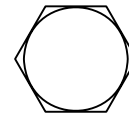
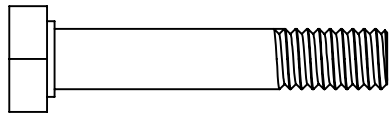

Part# 37 M8x45 Hex Head Bolt (Partial Thread)

Qty. 6

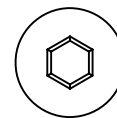
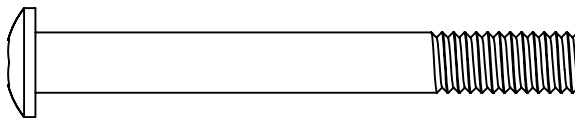

Part# 21 M8x72 Round Allen Head Bolt

Qty. 2

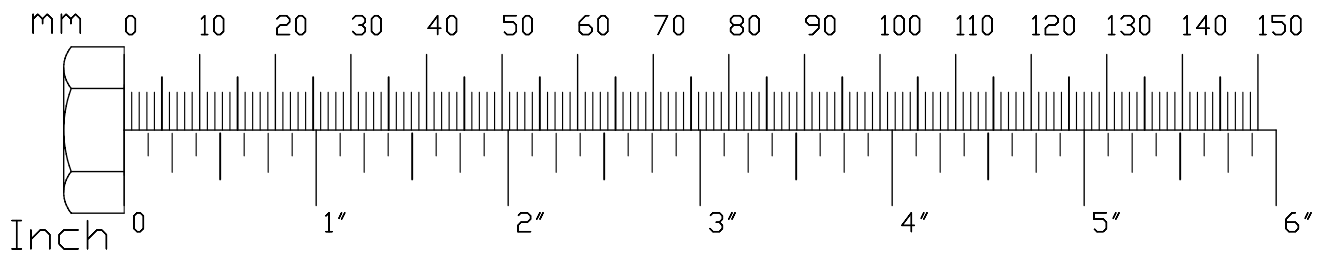

HARDWARE

(Actual Size Shown)

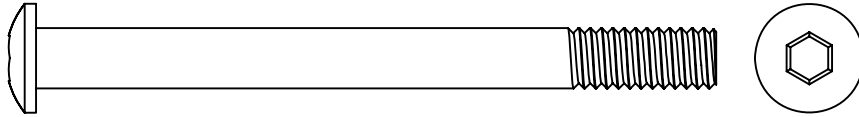

Part# 4

M8x90

Round Allen Head Bolt

Qty. 2



Part# 57

M4x10

Cross Pan Head Screw

Qty. 2



Part# 16

M5x10

Cross Pan Head Screw

Qty. 4



Part# 27

ST3.5x10

Phillips Head Screw

Qty. 4

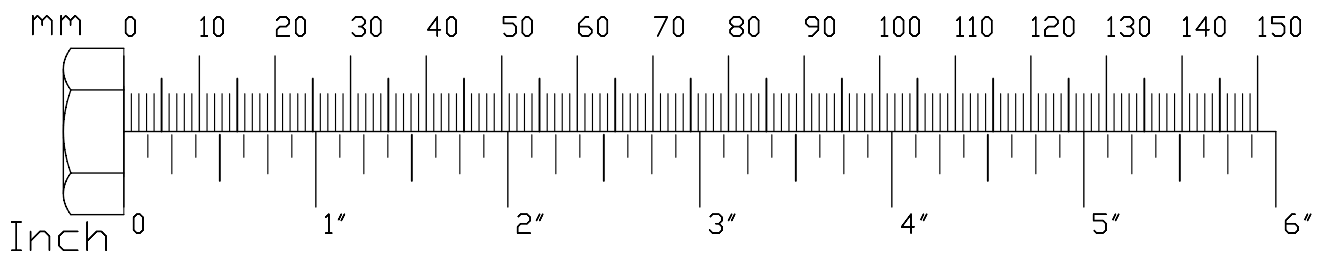

HARDWARE

(Actual Size Shown)

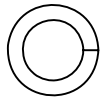

Part# 44 M8 Spring Washer Qty. 8



Part# 11 M10 Spring Washer Qty. 4

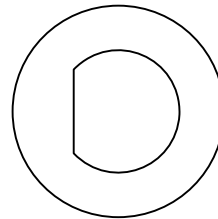
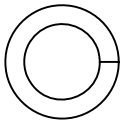

Part# 9 M16.2 D-Washer Qty. 4

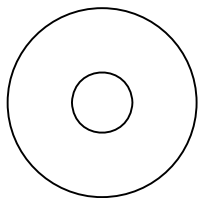
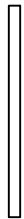

Part# 58 M8 Arc Washer Qty. 2

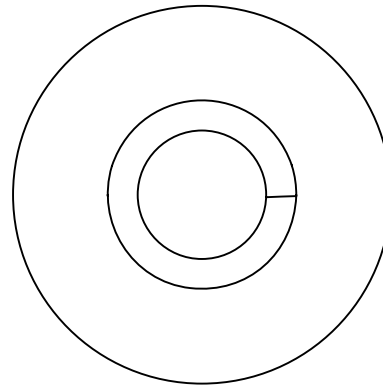

Part# 35 M17 Wave Washer Qty. 4

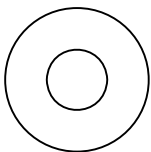

Part# 20 M8 Arc Washer Qty. 6



Part# 13 M8 Nylon Nut Qty. 10

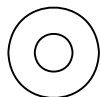
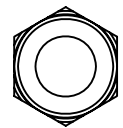

Part# 60 M5 Washer Qty. 2

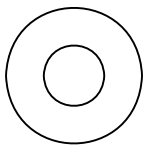

Part# 12 M8 Washer Qty. 10



mm 0 10 20 30 40 50 60 70 80 90 100 110 120 130 140 150



Inch 0 1" 2" 3" 4" 5" 6"

HARDWARE LIST

PART#	QTY	DESCRIPTION
A	1	Main Frame
B	1	Rear Leg
C	1	Front Leg
D	1	Upright
E	1	Shroud
F	1	Left Stride Bar
G	1	Right Stride Bar
H	1	Left Handle
I	1	Right Handle
J	1	Left Foot Plate
K	1	Right Foot Plate
L	1	Handle Bar
M	1	Left Front Handle Shroud
N	1	Right Front Handle Shroud
O	1	Right Rear Handle Shroud
P	1	Left Rear Handle Shroud
Q	1	Right Stride Shroud
R	1	Left Stride Shroud
S	2	Lower Foot Frame Shroud
T	2	Upper Foot Frame Shroud
U	1	Front Upright Shroud
V	1	Rear Upright Shroud
W	1	Console Logo
X	1	BF Shroud Badge
Y	2	Drive Wheel Logo

Part numbers are required when ordering parts.

HARDWARE LIST

PART#	QTY	DESCRIPTION	
1	2	Starter Batteries (Type AA)	<i>Non-Warranty Item</i>
2	2	Rear Leg End Cap	
4	2	Round Allen Head Bolt	M8x90
5	5	Washer	M10 (20OD x 2t)
6	5	Nylon Nut	M10
7	4	Plastic Bushing	16ID x 28OD x 16t
8	4	Bushing	10ID x 18 ODx 11t
9	4	D-Washer	16.2ID x 28OD x 14t x B5
10	4	Round Allen Head Bolt	M10x20
11	4	Spring Washer	M10
12	10	Washer	M8 (16OD x 1.5t)
13	10	Nylon Nut	M8
14	1	Left Foot Frame	
15	1	Right Foot Frame	
16	4	Cross Pan Head Screw	M5x10
17	1	Right Joint Frame	
18	2	Hex Head Bolt	M10x12
19	4	Bushing	12ID x 32OD x 15t
20	6	Arc Washer	M8 (19OD x 1.5t x R30)
21	2	Round Allen Head Bolt	M8x72
22	2	Front Leg End Cap	
25	6	Bushing	16ID x 31OD x23t
27	4	Phillips Head Screw	ST3.5 x 10
29	2	Foam Grip	Upper Handle
30	2	Round End Cap	Upper Handle
31	1	Console	
32	1	Console Battery Cover	
33	1	Cross Head Pan Screw	M5x55
34	1	Arc Washer	M5
35	4	Wave Washer	M17 (23OD x 0.3t)
36	4	Carriage Bolt	M8x45
37	6	Hex Head Bolt	M8x45
38	2	Hex Head Bolt	M10x55
39	1	Left Joint Frame	
40	2	Round End Cap	
41	2	Handle Bar Foam	
43	2	HR Cable Harness/HR Contact	
44	8	Spring Washer	M8
45	8	Round Allen Head Bolt	M8x16
48	1	Tension Controller	
50	1	Upper Harness	
51	2	Hex Head Bolt	M5
52	1	Lower Tension Cable	
53	1	Lower Harness	
54	1	Left Shroud	

Part numbers are required when ordering parts.

HARDWARE LIST

PART#	QTY	DESCRIPTION	
55	1	Left Crank	
56	1	Right Crank	
57	2	Cross Pan Head Screw	M4x10
58	2	Arc Washer	M8 (25OD x 2t x R39)
59	33	Phillips Head Screw	ST4.2x18
60	2	Washer	M5 (12OD)
61	1	Upright Axis	
62	2	Washer	M12 (24OD x 1.5t)
63	1	Right Shroud	
64	2	Shroud Cover	
65	2	Drive Wheel	
66	2	Shaft Spring Ring	12ID
67	6	Brake Magnet	
68	1	Brake Magnet Frame	
69	1	Tension Spring	
70	1	Shaft	M6 x 20 x ϕ 12 x 59.5
71	2	Hex Head Bolt	M6x15
72	6	Spring Washer	M6 (10.3OD)
73	2	Washer	M6 (12OD x 1.5t)
74	2	Shaft Spring Washer	M20
75	2	Bearing	ϕ 20 x ϕ 37 x 9t (6904Z)
76	4	Allen Head Bolt	M6x15
77	1	Plastic Flywheel	
78	1	Belt	
79	1	Plastic Flywheel Shaft	
80	4	Nylon Nut	M6
81	1	Cock Wheel	
82	1	Hex Head Bolt	M5x60
83	2	Hex Head Bolt	M6
84	1	Bushing	10ID x 18OD x 6t
85	1	Allen Head Bolt	M10x40
86	1	Magnet Sensor	
87	2	Phillips Head Screw	ST3x10
88	2	Hexagon Bolt	M10x1
89	2	Chain Adjuster Bolt	M6x50
90	2	Chain Adjuster U Washer	31 x 11 x 8mm
91	8	Washer	M5 (12OD x 1.5t)
92	1	Flywheel Shaft	
93	2	Tapered Nut	M10x1
94	1	Flywheel	
95	2	Bushing	M10x3
96	2	Flange Nut	M10x1.25
97	1	HR Magnet	
98	1	Nut Cover	
99	1	Plastic Component	

Part numbers are required when ordering parts.

EXPLODED VIEW DIAGRAM

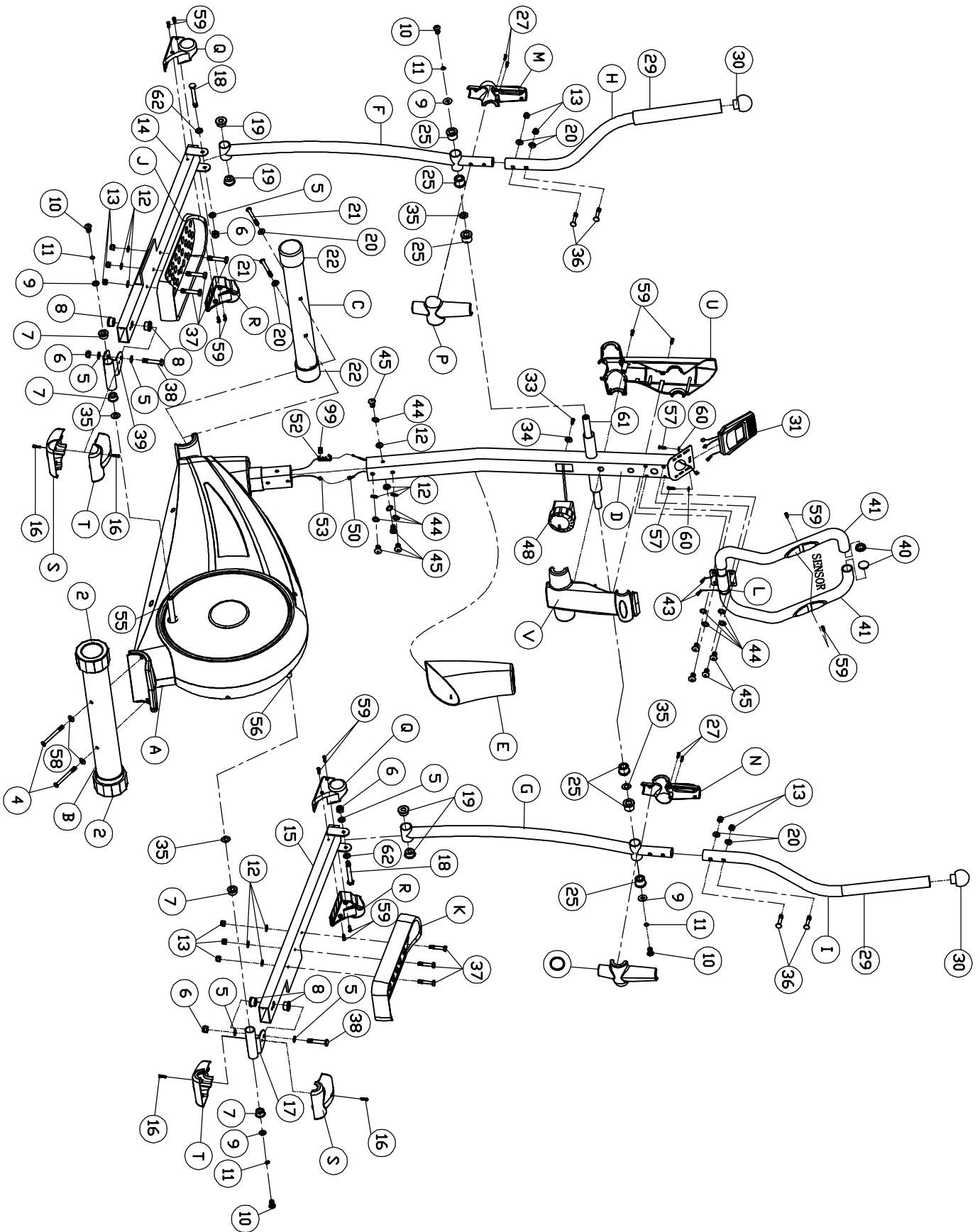

EXPLODED VIEW DIAGRAM

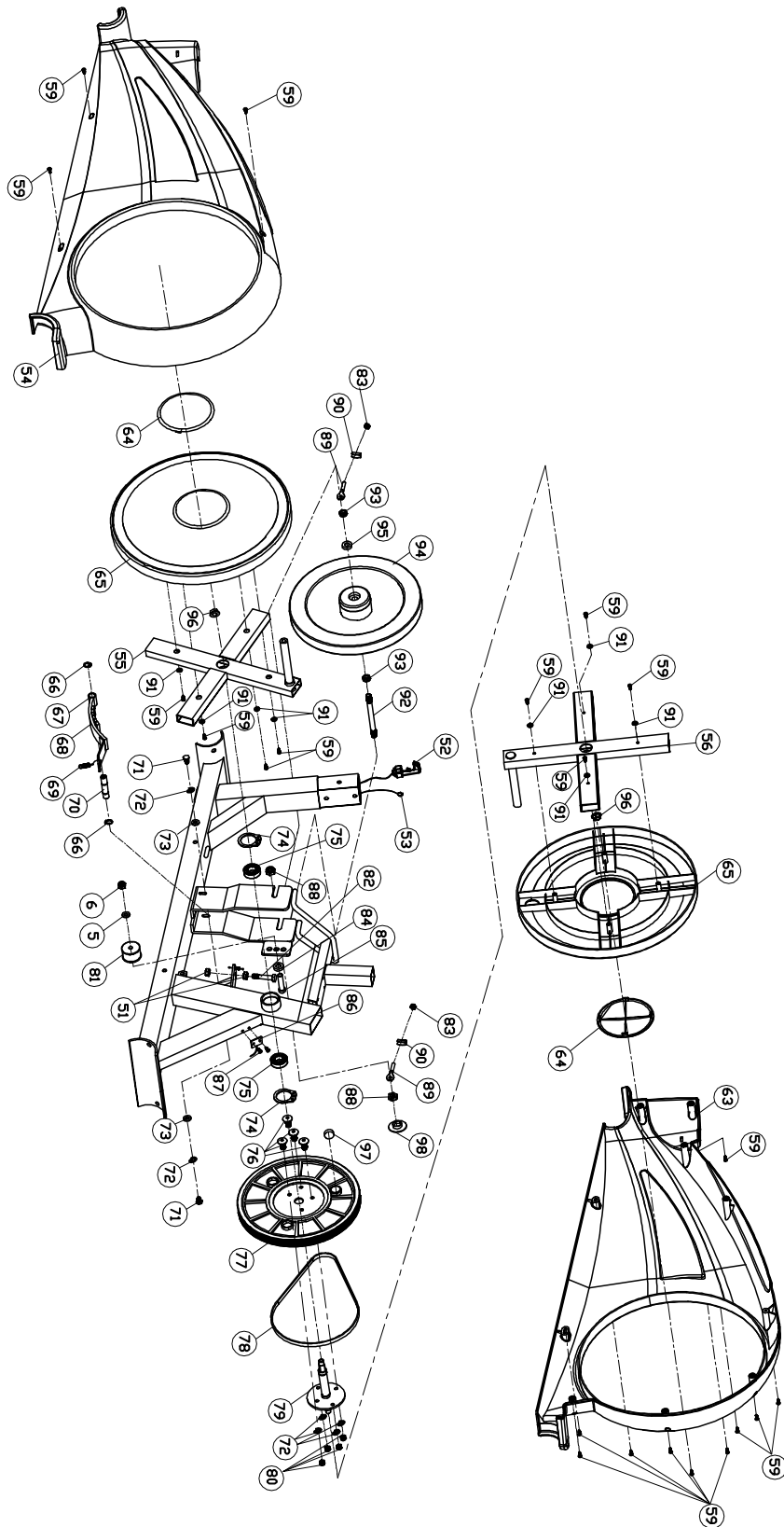

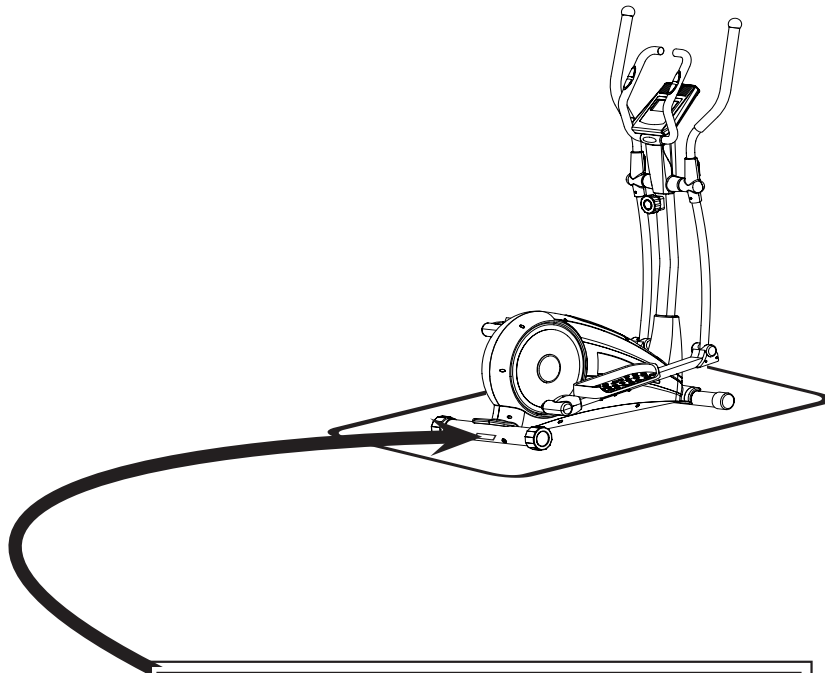

Serial Number is Located on the Frame

Model Name: BFCT1R

Purchase Date: _____

Serial Number: _____



www.Bestfitness.com