

LETTERCUT

TEMPLATE FOR LETTERS 5 inch Roman Serif

INSTRUCTIONS:

1. Print template pages at full size for accuracy.
2. Assemble template.
3. Tape the template in place.
Use a level to ensure your template is straight.
4. Pre-drill the screw holes - using house numbers as a guide.
5. Fasten with screws through the number and spacer.

Lining your letters up:

Solid lines on the top and sides of page mark the centers of the letters so you can easily align your letters vertically or horizontally. When you assemble your template - tape pages together so solid lines line up.

Heights vary slightly - Numbers and letters are all designed for visual appeal. A slight variation in number height and width is intentional.

Spacing your letters :

These dotted lines create even spacing of letters. Fold template on the dotted line and tape papers together so dotted lines match. **These are guidelines. You are free to add or subtract space by adding or decreasing space between dotted lines so that it is visually pleasing to you.*

Suggested spacing between 5" tall letters:
For horizontal placement is 0.75 - 1.25" between letters.
For vertical placement - allow 1 - 1.5" between letters.

LETTERCUT

For letter - print page:

- A - page 3
- B - page 4
- C - page 5
- D - page 6
- E - page 7
- F - page 8
- G - page 9
- H - page 10
- I - page 11
- J - page 12
- K - page 13
- L - page 14
- M - page 15
- N - page 16
- O - page 17
- P - page 18
- Q - page 19
- R - page 20
- S - page 21
- T - page 22
- U - page 23
- V - page 24
- W - page 25
- X - page 26
- Y - page 27
- Z - page 28

Send Jane an email: Jane@MyLettercut.com
if this template does not work for you

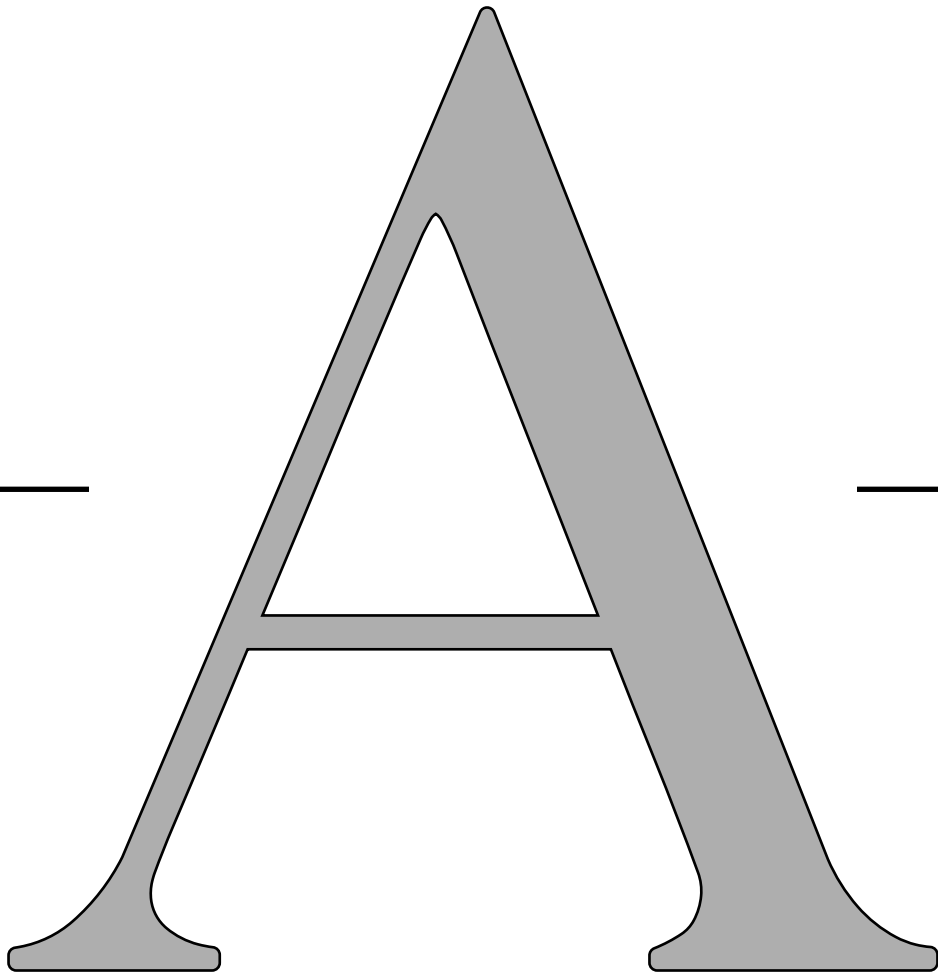

B

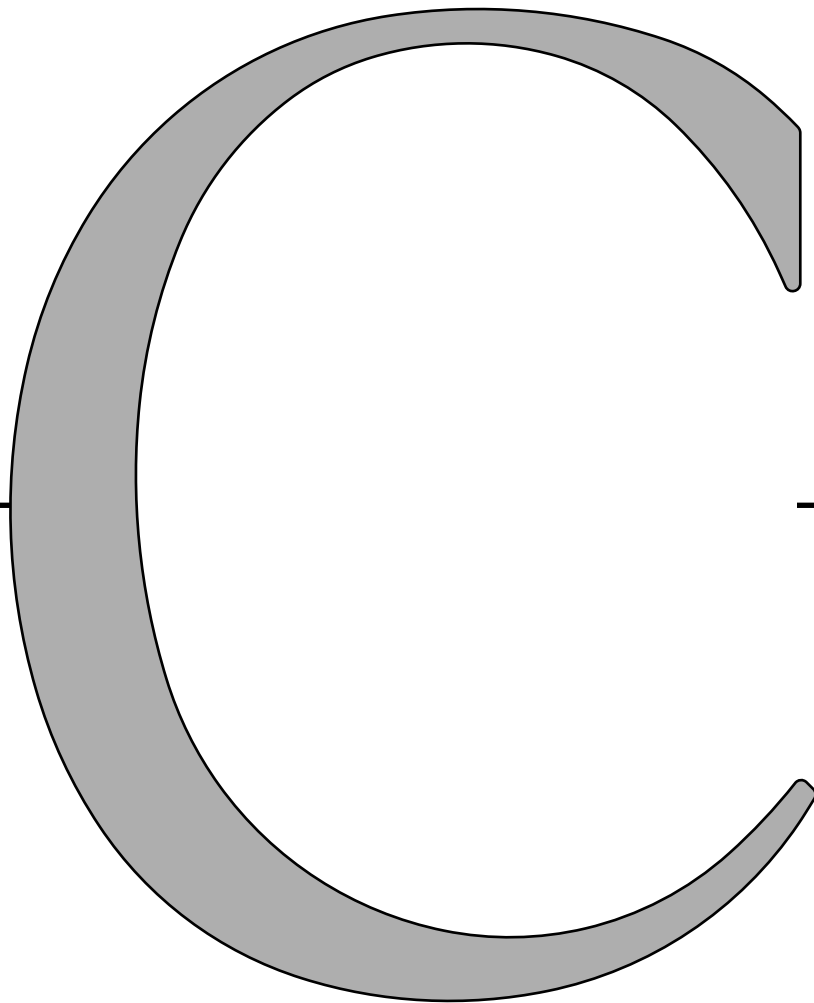

D

E

F

G

H

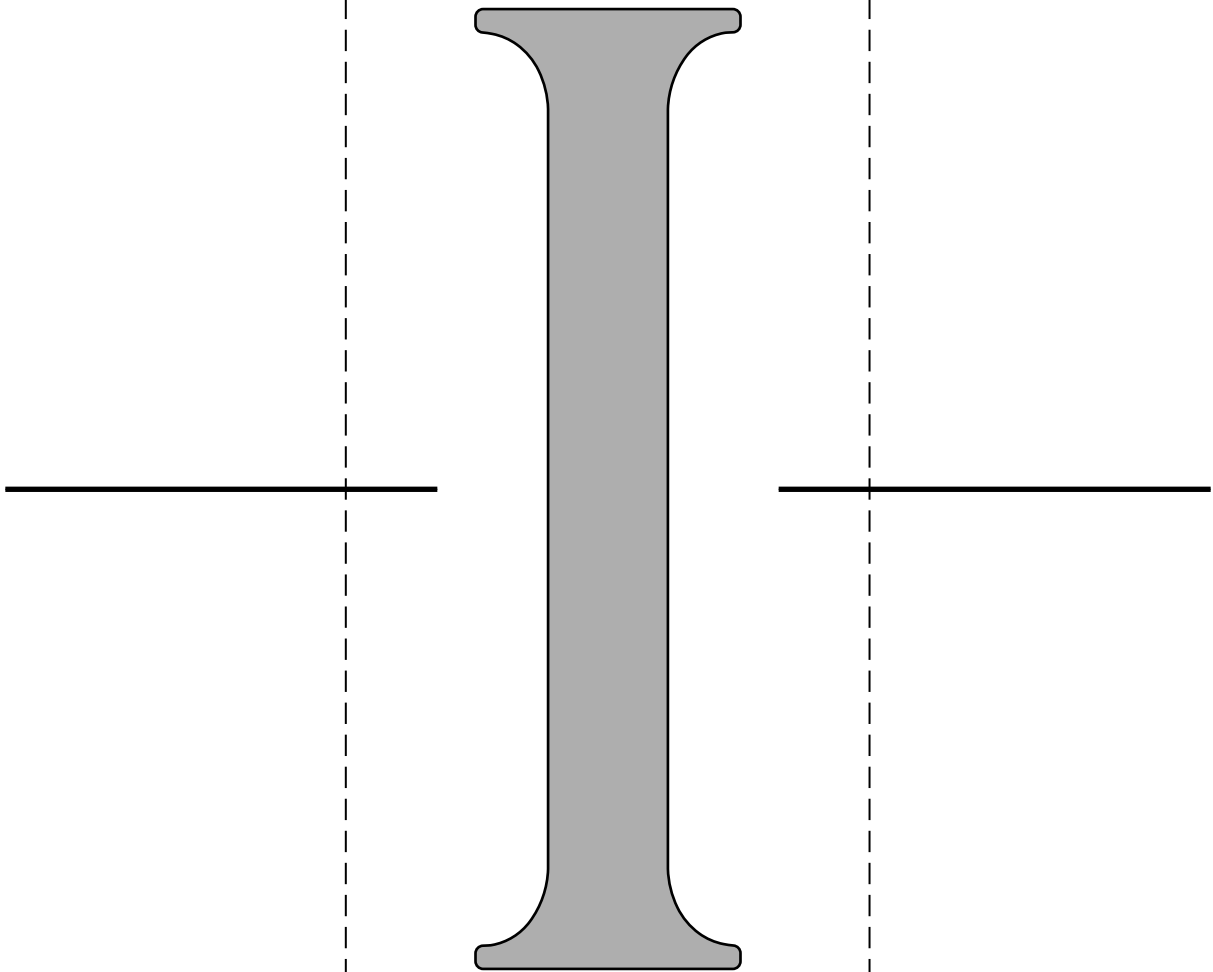

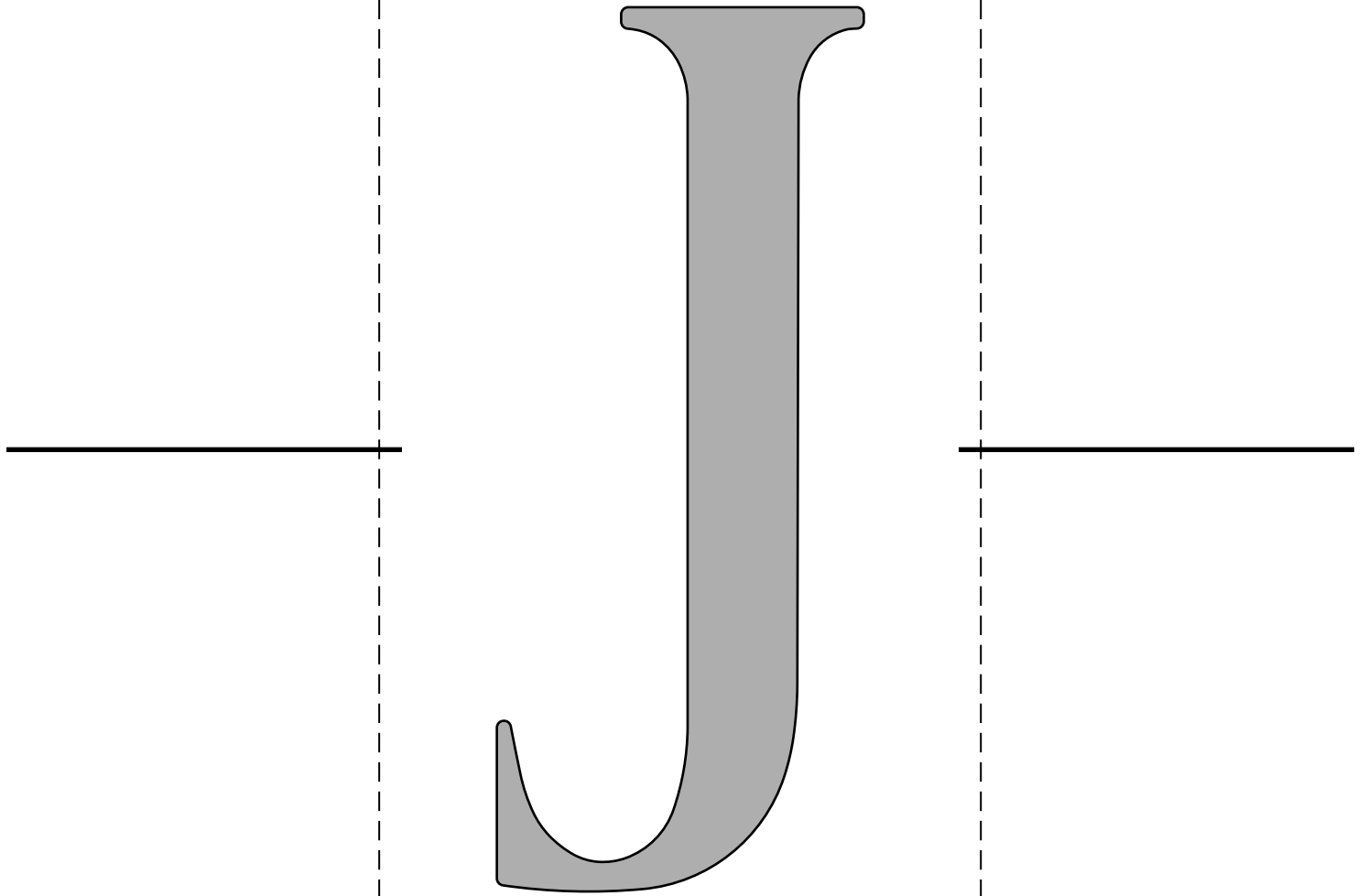

K

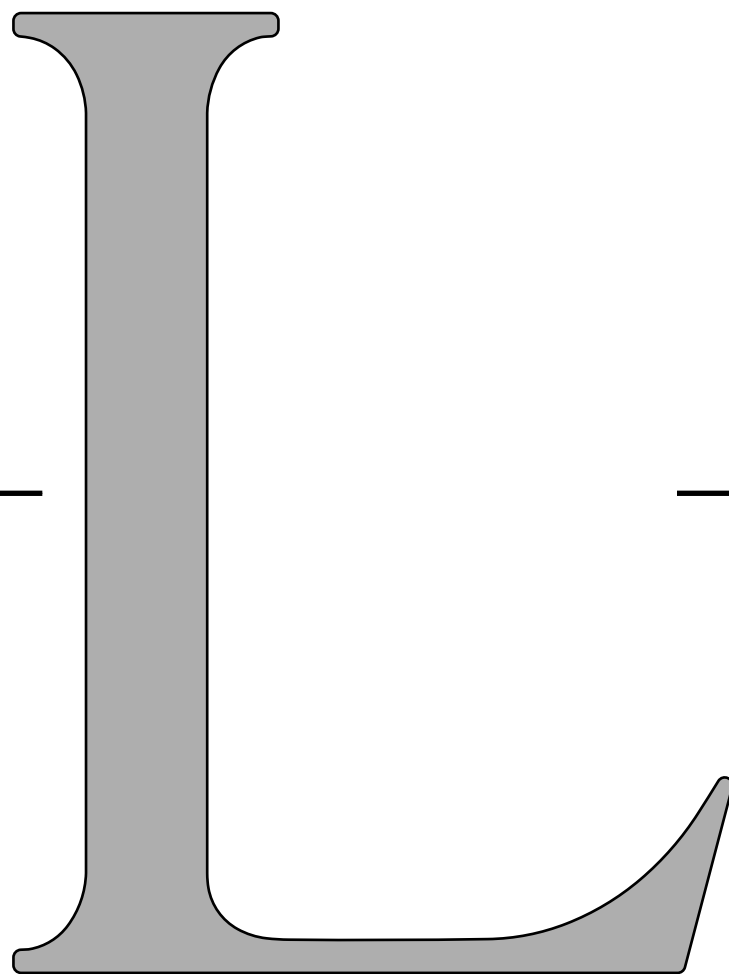

M M

Ni

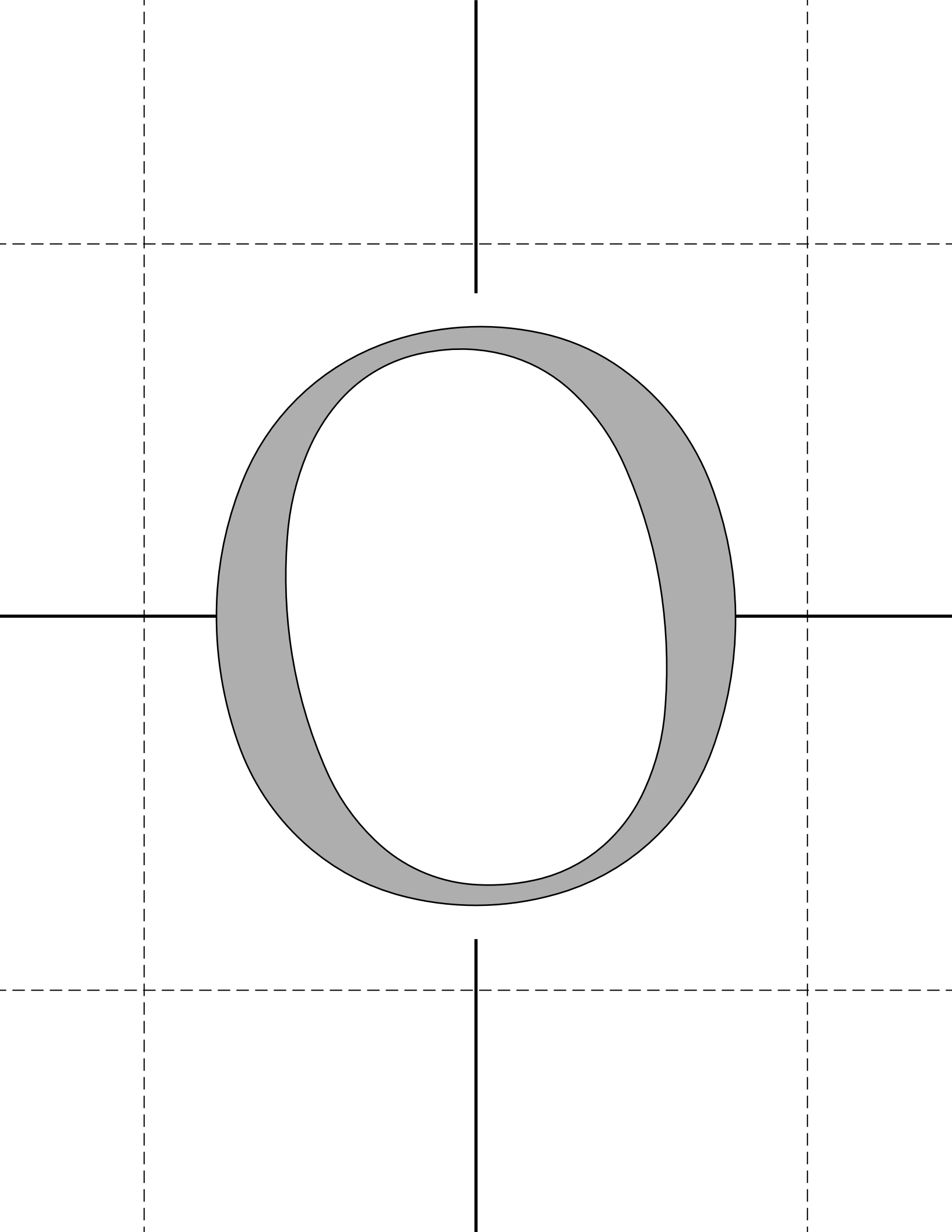

P

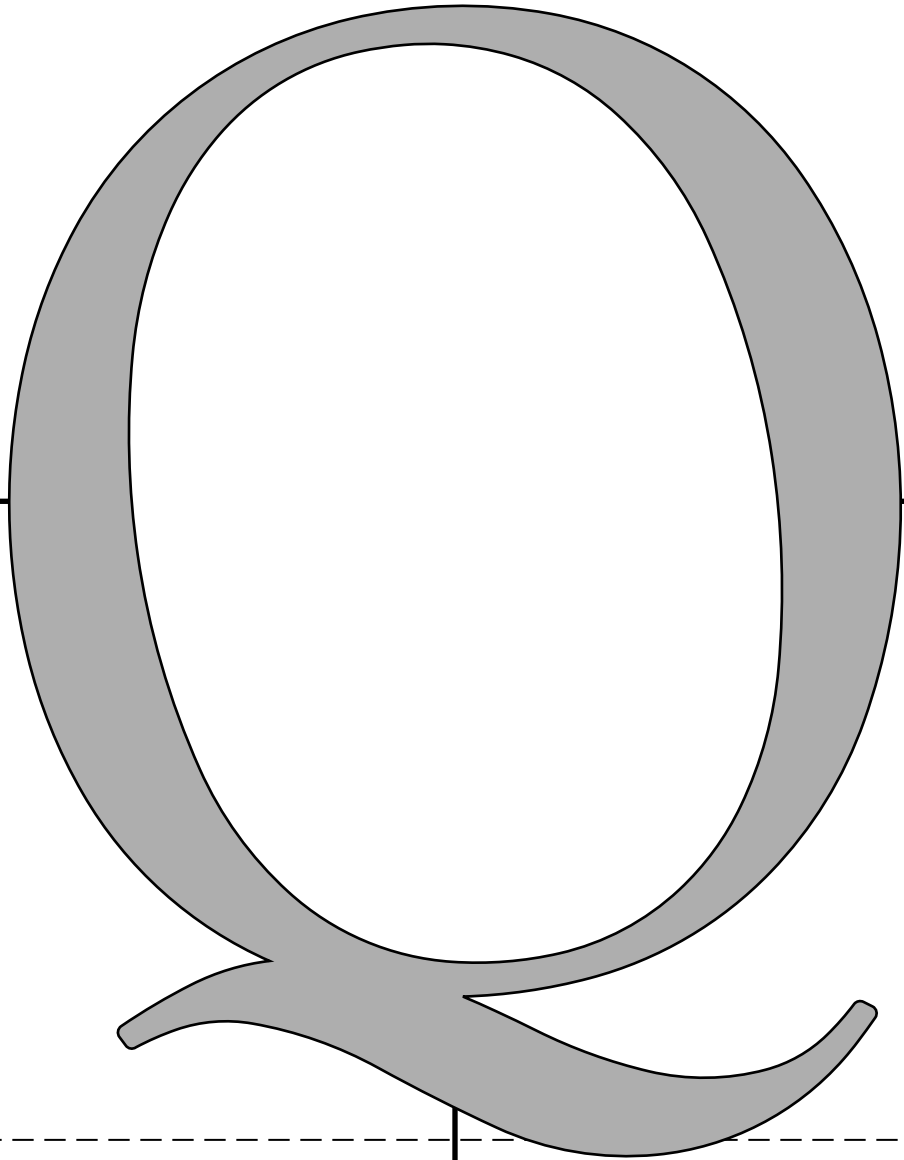

R

S

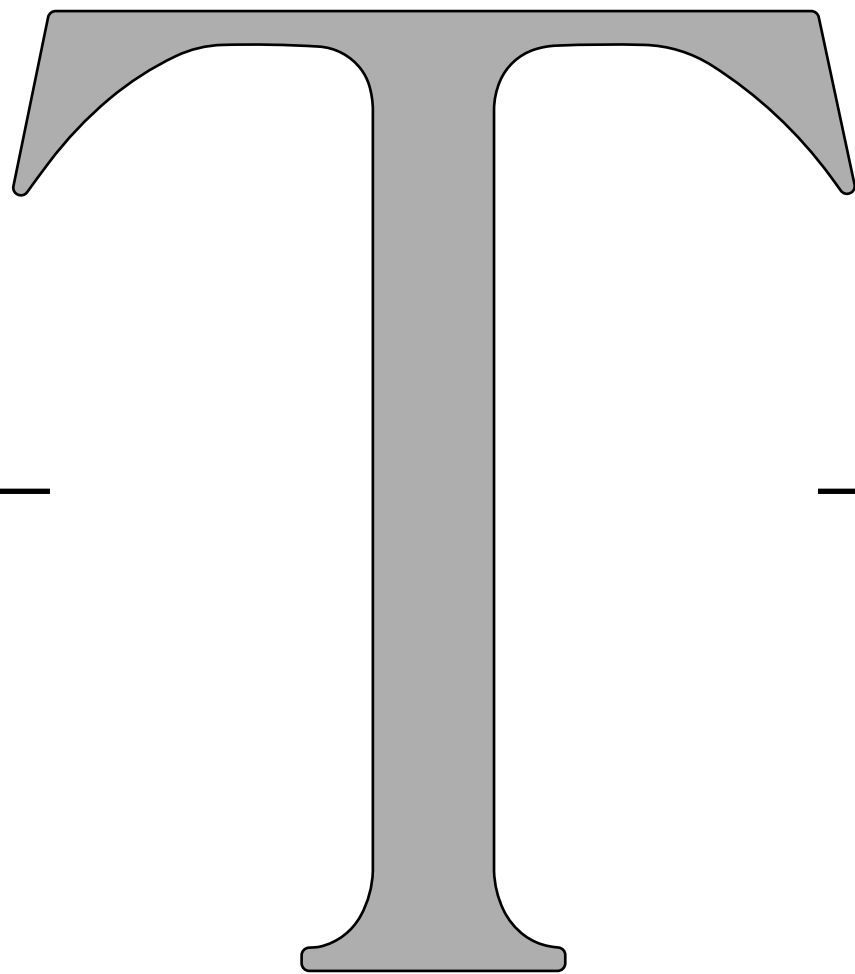

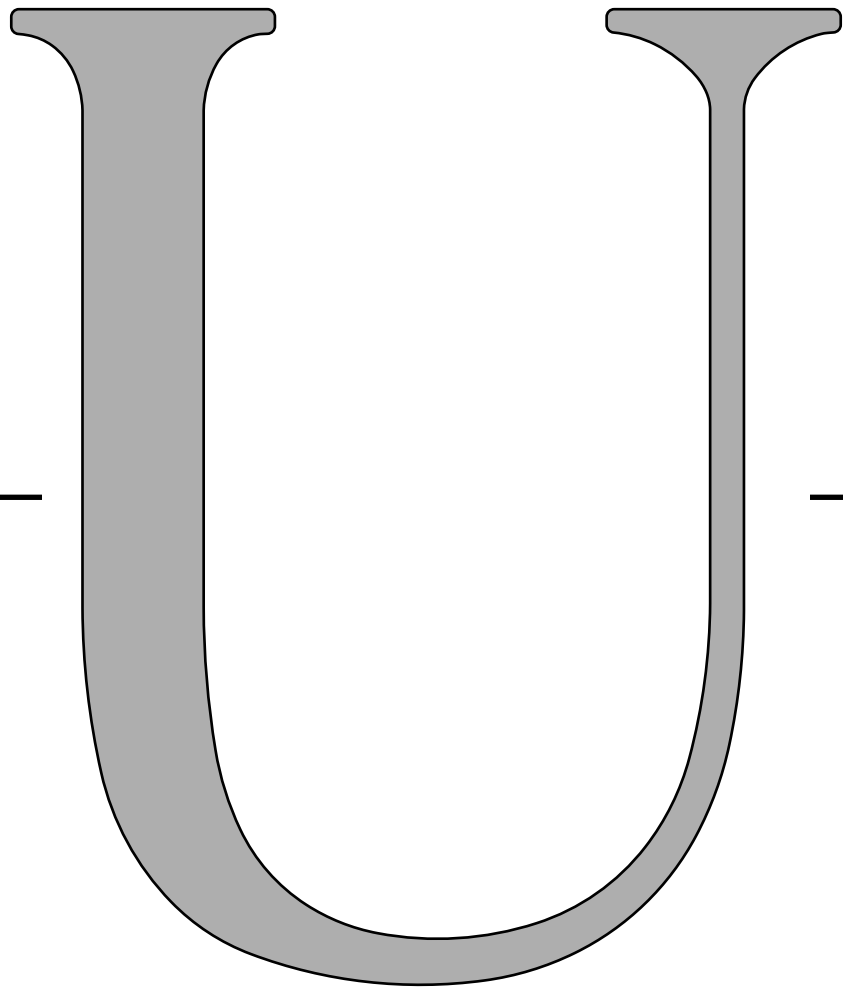

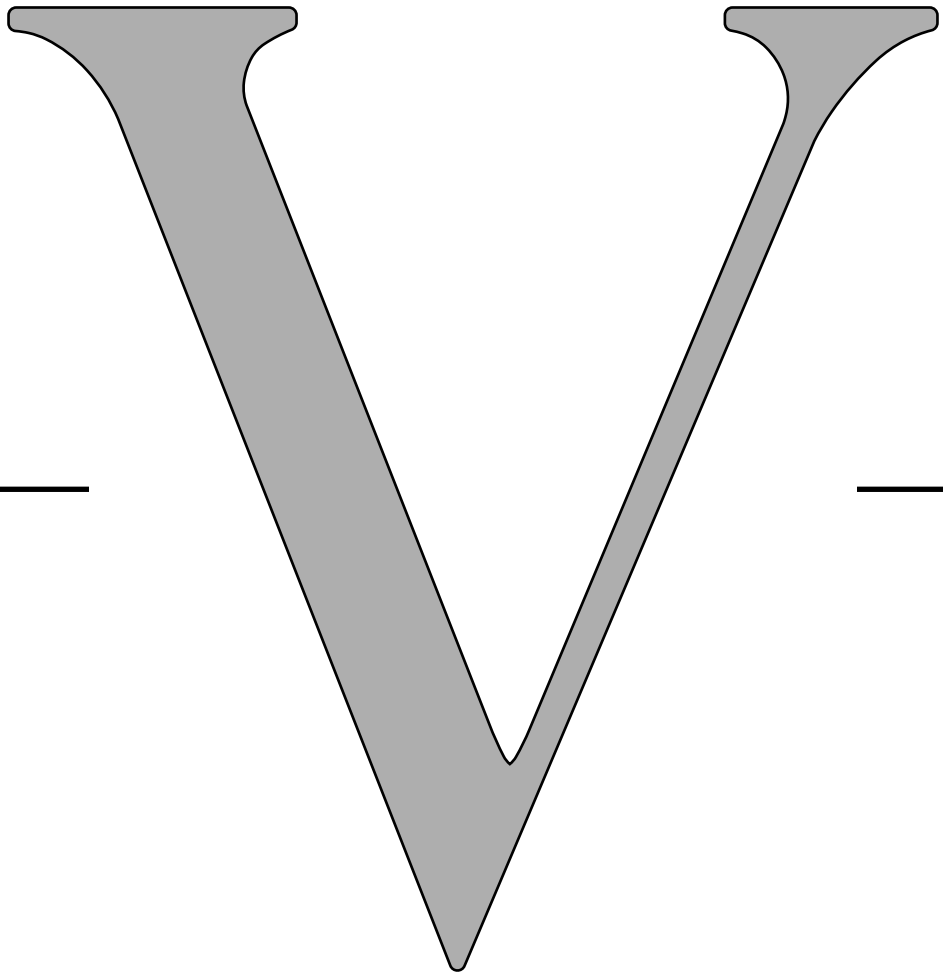

*The dashed lines for spacing land exactly
on the edge of a 8.5 paper.*

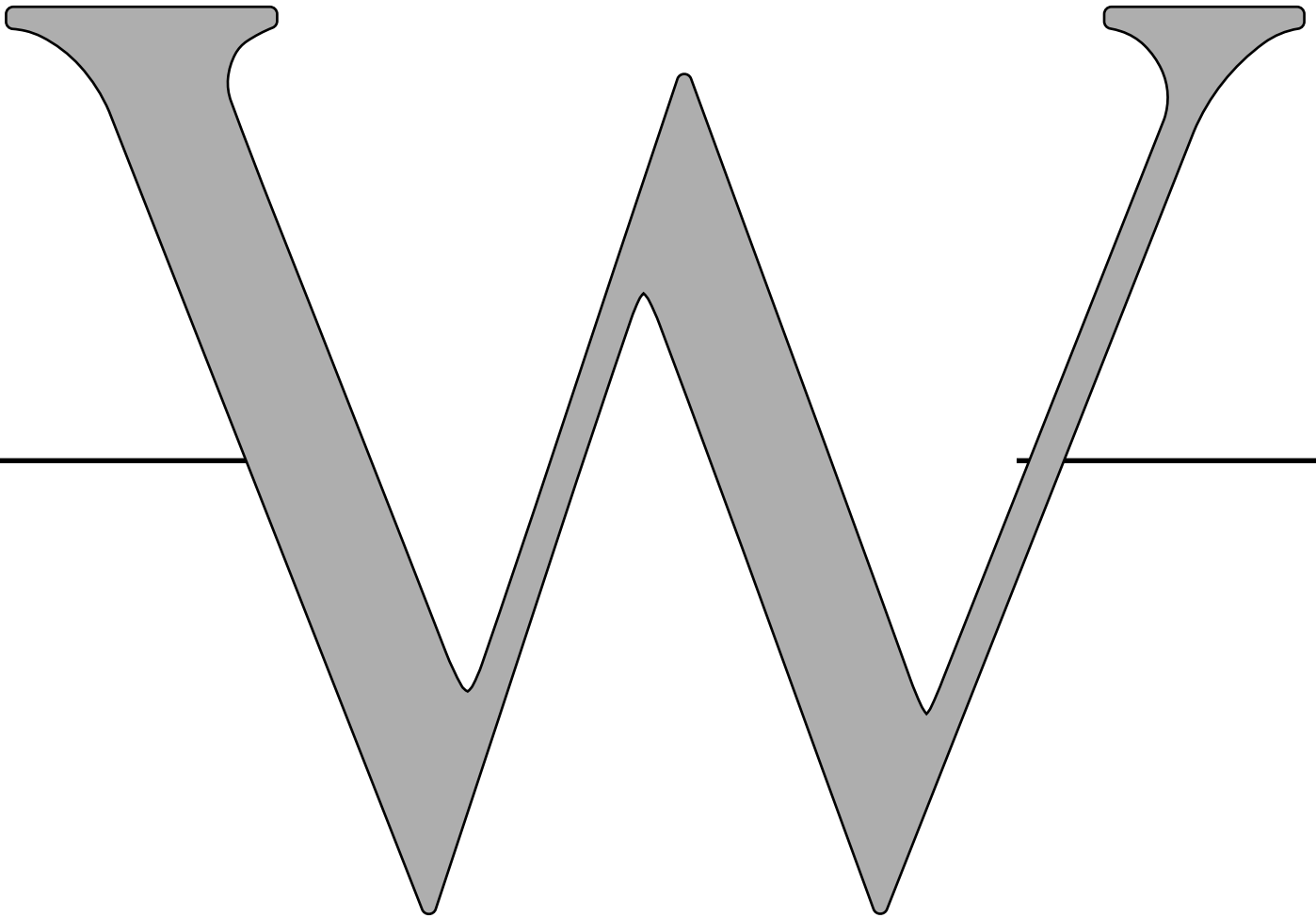

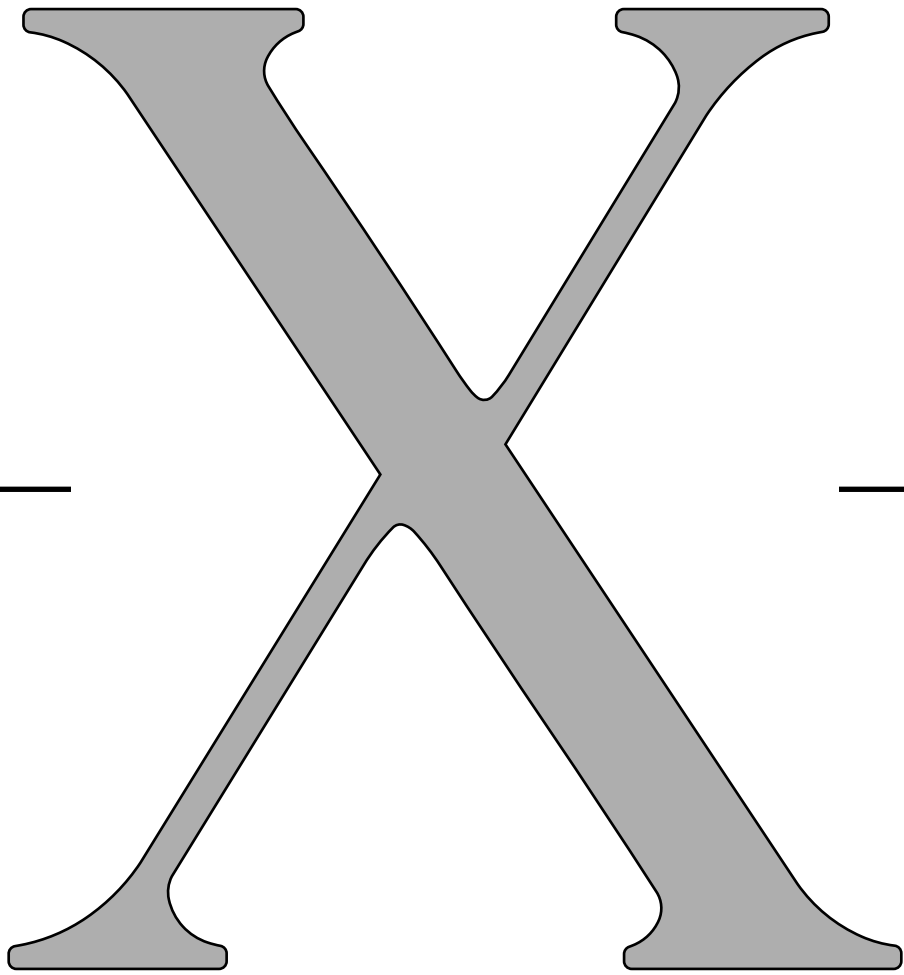

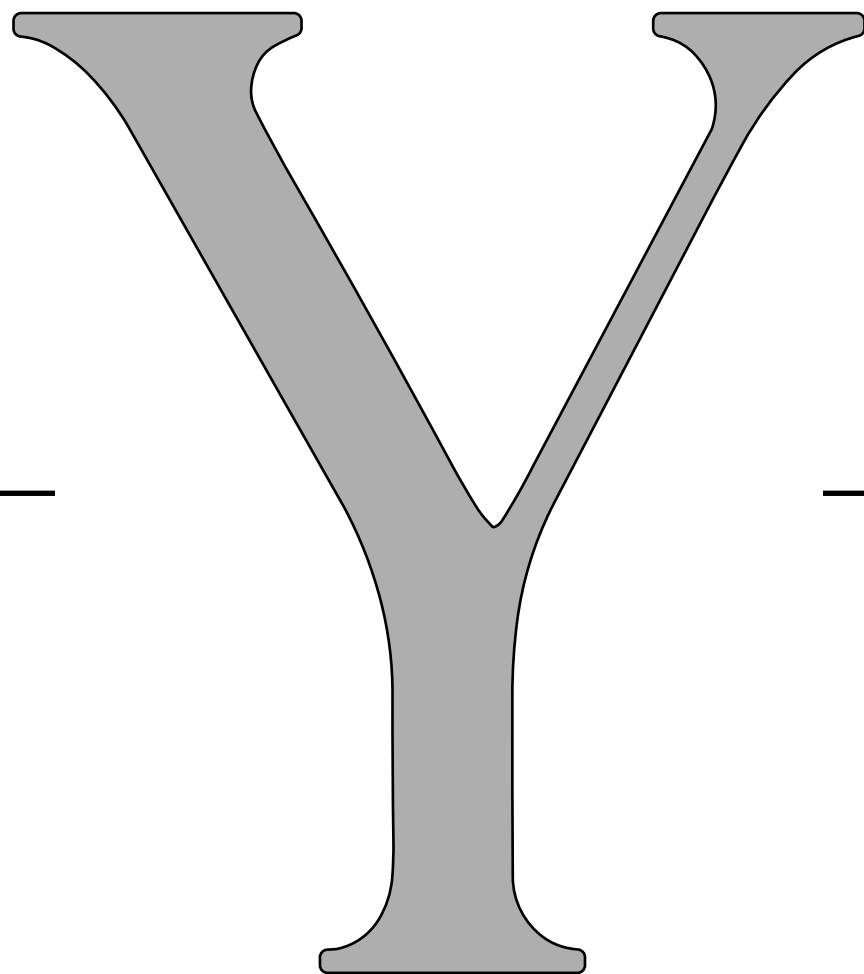

Z