

LETTERCUT

lowercase letter template 5 inch CLASSIC MODERN

INSTRUCTIONS:

1. Print template pages at full size for accuracy.
2. Assemble template.
3. Tape the template in place.
Use a level to ensure your template is straight.
4. Pre-drill the screw holes - using house numbers as a guide.
5. Fasten with screws through the number and spacer.

Lining your letters up:

Solid lines on the top and sides of page mark the centers of the letters so you can easily align your letters vertically or horizontally. When you assemble your template - tape pages together so solid lines line up.

Heights vary slightly - Numbers and letters are all designed for visual appeal. A slight variation in number height and width is intentional.

Spacing your letters :

These dotted lines create even spacing of letters
Fold template on the dotted line and tape papers together so dotted lines match.
*Easily add or subtract space by adding or decreasing space between dotted lines.

Suggested spacing between 5" tall letters:
For horizontal placement is 0.75 - 1.25" between letters.
For vertical placement - allow 1 - 1.5" between letters.

LETTERCUT

For letter - print page:

- a - page 3
- b - page 4
- c - page 5
- d - page 6
- e - page 7
- f - page 8
- g - page 9
- h - page 10
- i - page 11
- j - page 12
- k - page 13
- l - page 14
- m - page 15
- n - page 16
- o - page 17
- p - page 18
- q - page 19
- r - page 20
- s - page 21
- t - page 22
- u - page 23
- v - page 24
- w - page 25
- x - page 26
- y - page 27
- z - page 28

Send Jane an email: Jane@MyLettercut.com
if this template does not work for you

Q

b

C

Q

e

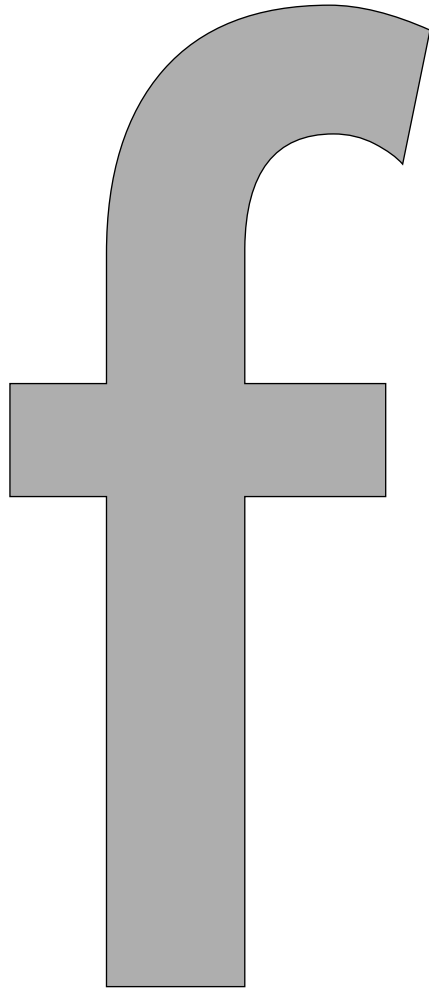

g

h

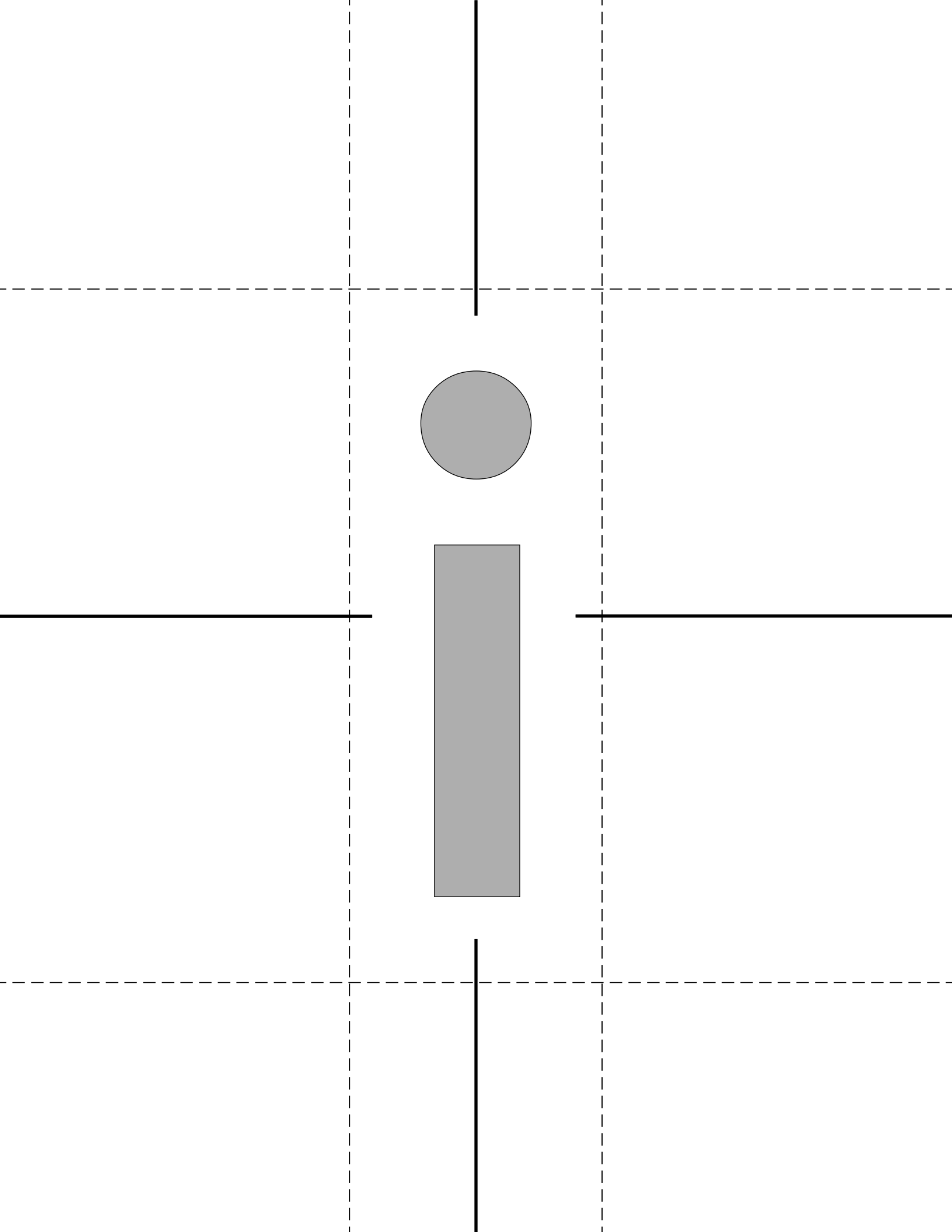

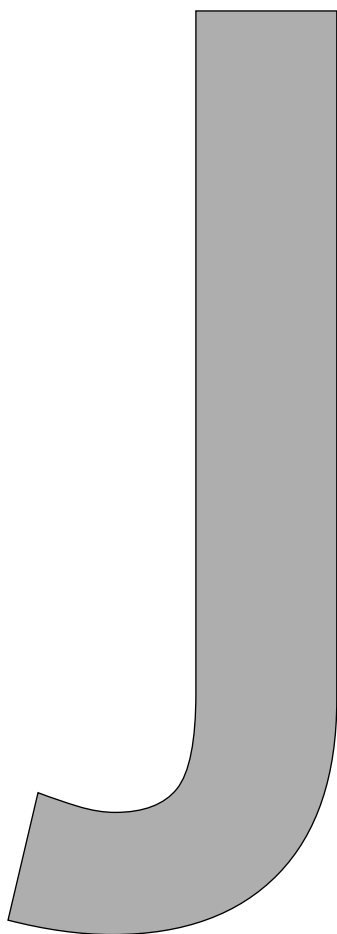
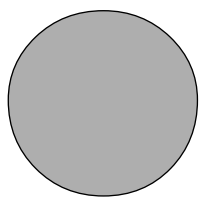

k

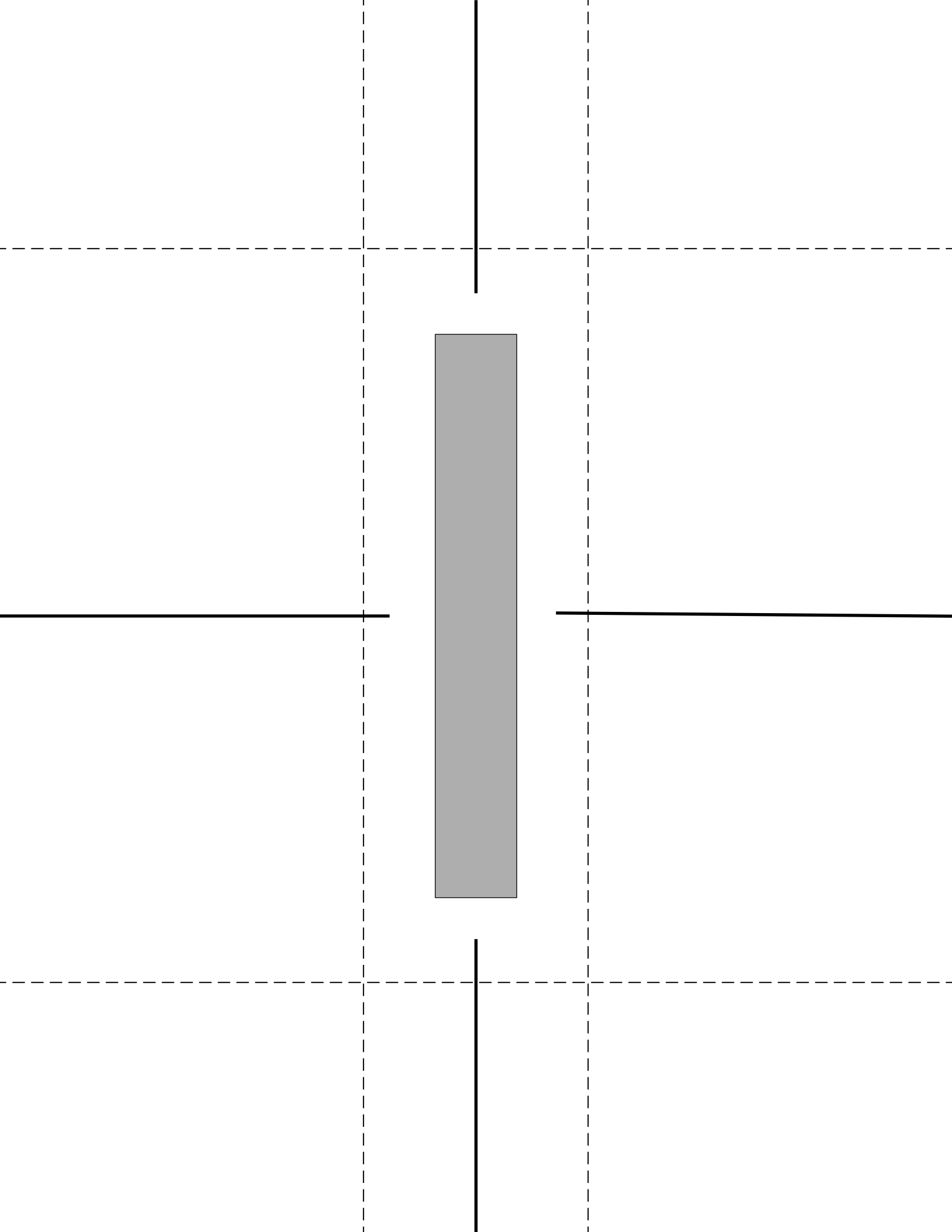

n n

n

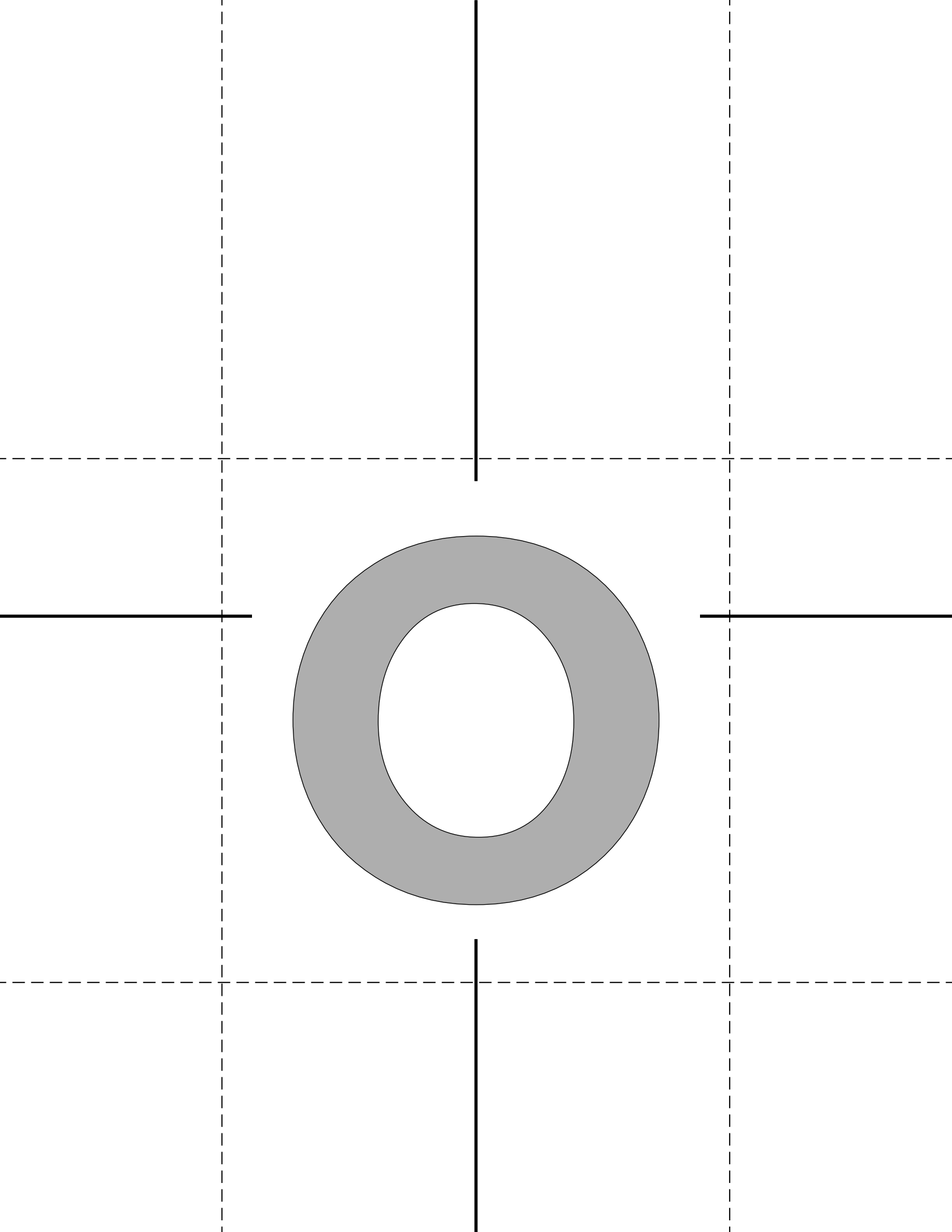

P

Q

r

S

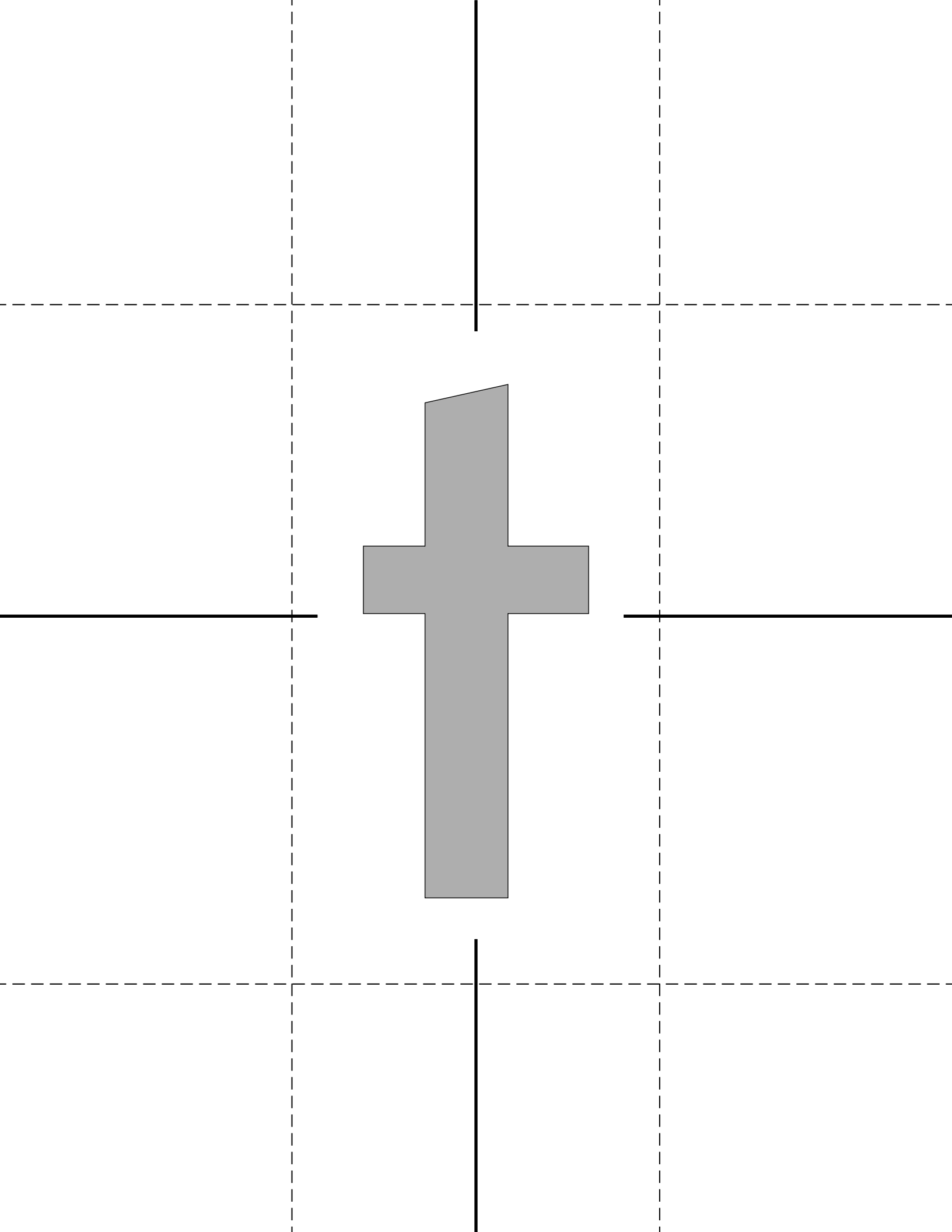

u

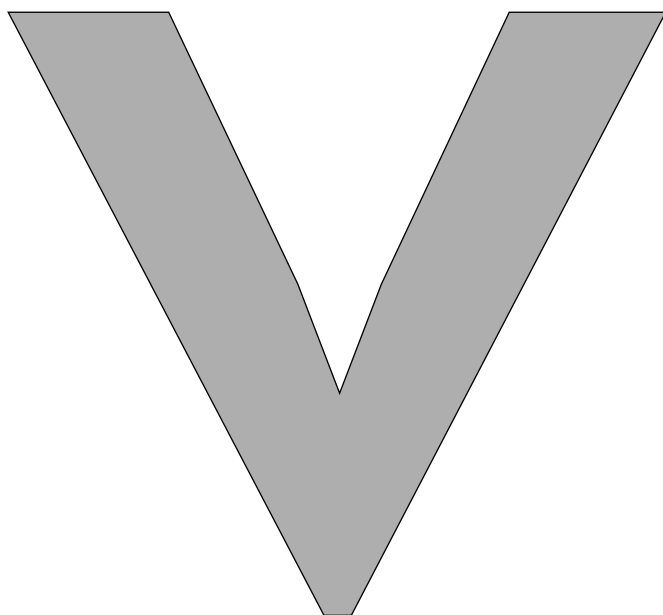

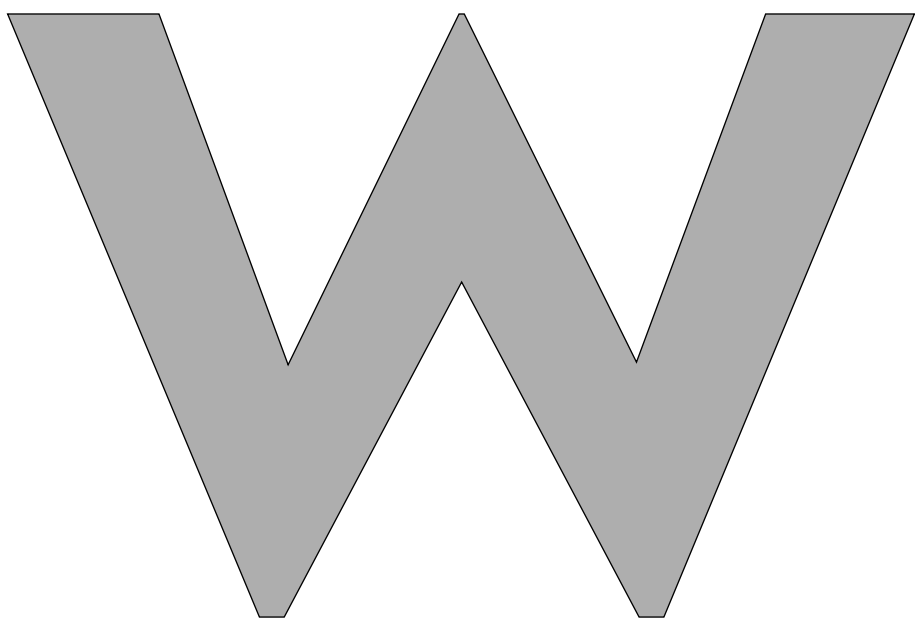

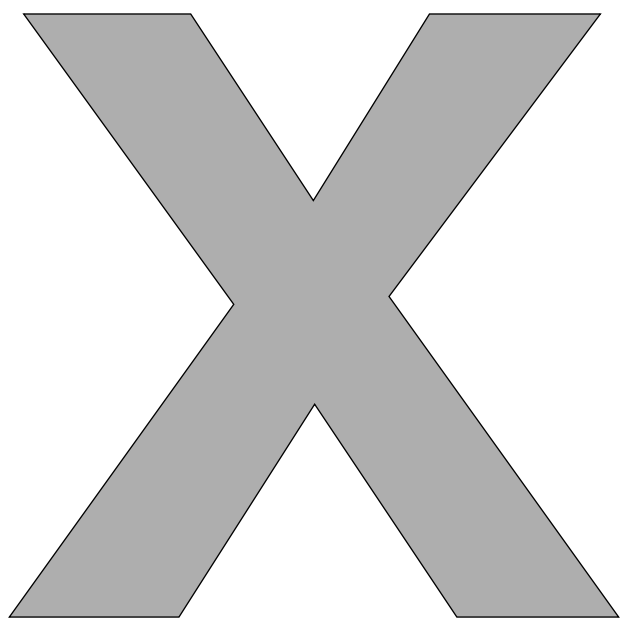

Y

Z